

ILLUSTRATED PARTS LIST

MFG. ID NO. 96061033602

CUSTOMER CATALOG NO. M175H38RB

PRODUCT NO. 960 61 03-36

TRACTOR -- MODEL NO. M175H38RB (96061033602), PRODUCT NO. 960 61 03-36
DECALS 27

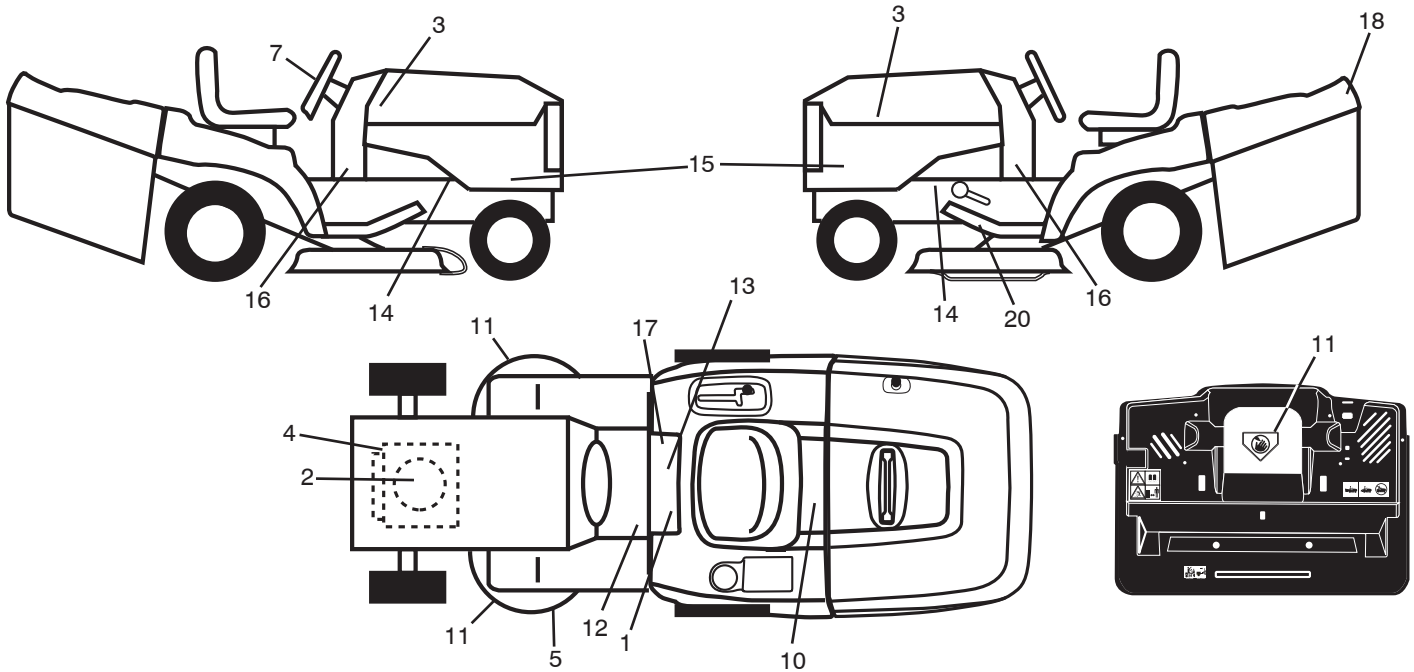

KEY NO.	PART NO.	DESCRIPTION
1	581 57 81-01	Decal, Warning Syms. CE
2	532 40 88-31	Decal, Hp Engine
3	532 43 83-82	Decal, Hood RH/LH
4	581 57 97-01	Decal, Warning Eng. Syms.
5	532 18 78-11	Decal, Deck ENVIRO
7	532 43 79-66	Decal, Ins Strg Whl
10	532 14 50-05	Decal, Bat Dan/Poi P/L Sym Wpn
11	581 57 91-01	Decal, Mower Cut Finger CE
12	581 72 40-01	Decal, Brake/Clutch Symbol
13	581 72 48-01	Decal, Bypass

KEY NO.	PART NO.	DESCRIPTION
14	581 57 96-01	Decal, Chassis Hot Muffler
15	532 44 44-35	Decal, Panel SD
16	532 18 56-51	Decal, Turbo
17	581 57 80-01	Decal, Saddle Brake Parking
18	532 44 44-52	Decal, Fender
20	581 58 00-05	Decal, Deck Sch
--	581 72 49-01	Decal, Lift Handle
--	532 18 10-90	Pad Footrest RH
--	532 18 10-91	Pad Footrest LH
--	581 36 39-40	Manual, Operator's English

WHEELS & TIRES

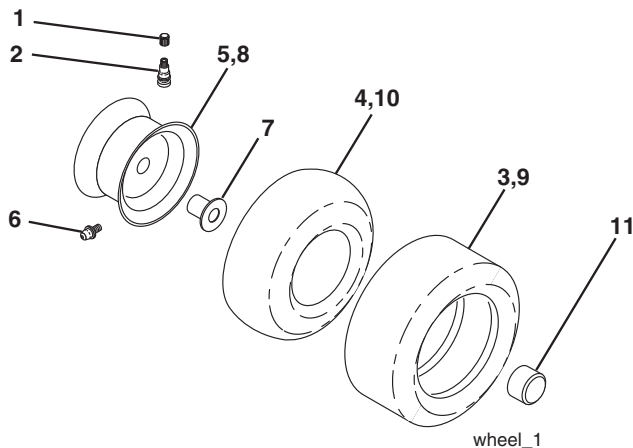

KEY NO.	PART NO.	DESCRIPTION
1	532 05 91-92	Cap Valve Tire
2	532 06 51-39	Stem Valve
3	532 10 62-22	Tire F Ts 15 x 6 0 - 6 Service
4	532 05 99-04	Tube Inner Front #35060
5	532 12 51-21	Rim Asm 6" Front Service
6	532 12 49-57	Fitting Grease
7	532 12 49-59	Bearing Flange
8	532 12 51-22	Rim Asm 8" Rear Service
9	532 13 84-68	Tire R Ts 20 x 8-8 C. Service
10	532 12 49-26	Tube Rear 9 5 x 8 Service
11	532 19 32-68	Cap Axle Blk 1 50 x 1 00
--	532 14 43-34	Sealant, Tire (10 oz. tube)

NOTE: All component dimensions given in U.S. inches
 1 inch = 25.4 mm

TRACTOR -- MODEL NO. M175H38RB (96061033602), PRODUCT NO. 960 61 03-36 SCHEMATIC 38

SCH08

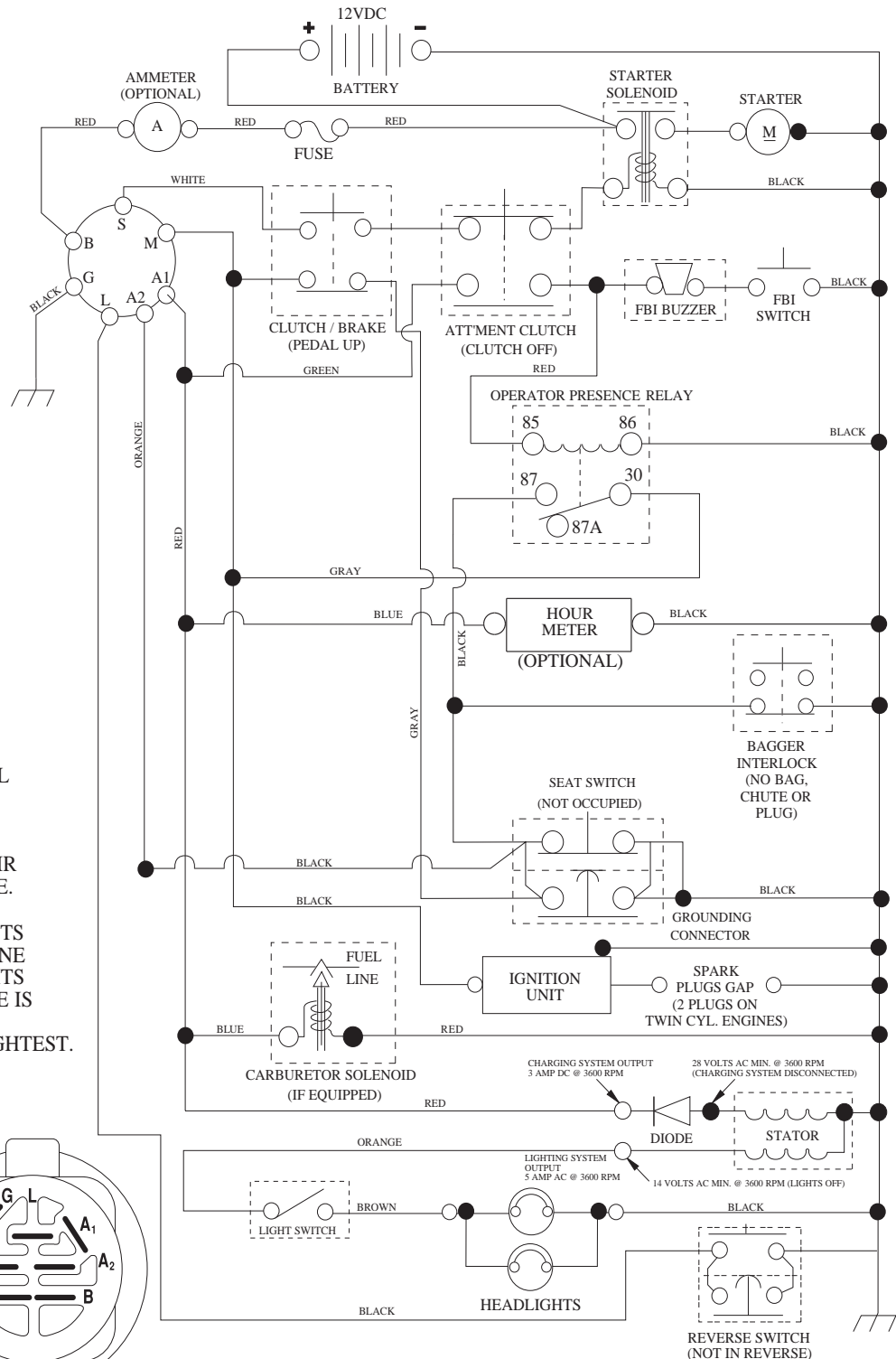

NOTE
YOUR TRACTOR IS EQUIPPED WITH A SPECIAL ALTERNATOR SYSTEM. THE LIGHTS ARE NOT CONNECTED TO THE BATTERY, BUT HAVE THEIR OWN ELECTRICAL SOURCE. BECAUSE OF THIS, THE BRIGHTNESS OF THE LIGHTS WILL CHANGE WITH ENGINE SPEED. AT IDLE THE LIGHTS WILL DIM. AS THE ENGINE IS SPEEDED UP, THE LIGHTS WILL BECOME THEIR BRIGHTEST.

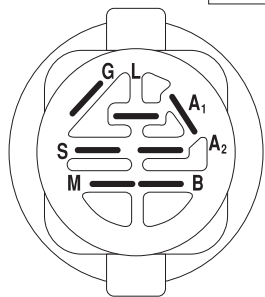

IGNITION SWITCH

POSITION	CIRCUIT "MAKE"
OFF	M+G+A1
RUN/OVERRIDE	B+A1
RUN	B+A1 L+A2
START	B + S + A1

WIRING INSULATED CLIPS
NOTE: IF WIRING INSULATED CLIPS WERE REMOVED FOR SERVICING OF UNIT, THEY SHOULD BE RE-INSTALLED TO PROPERLY SECURE YOUR WIRING.

REMOVABLE CONNECTIONS

NON-REMOVABLE CONNECTIONS

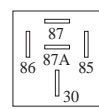

RELAY

TRACTOR -- MODEL NO. M175H38RB (96061033602), PRODUCT NO. 960 61 03-36
ELECTRICAL **32**

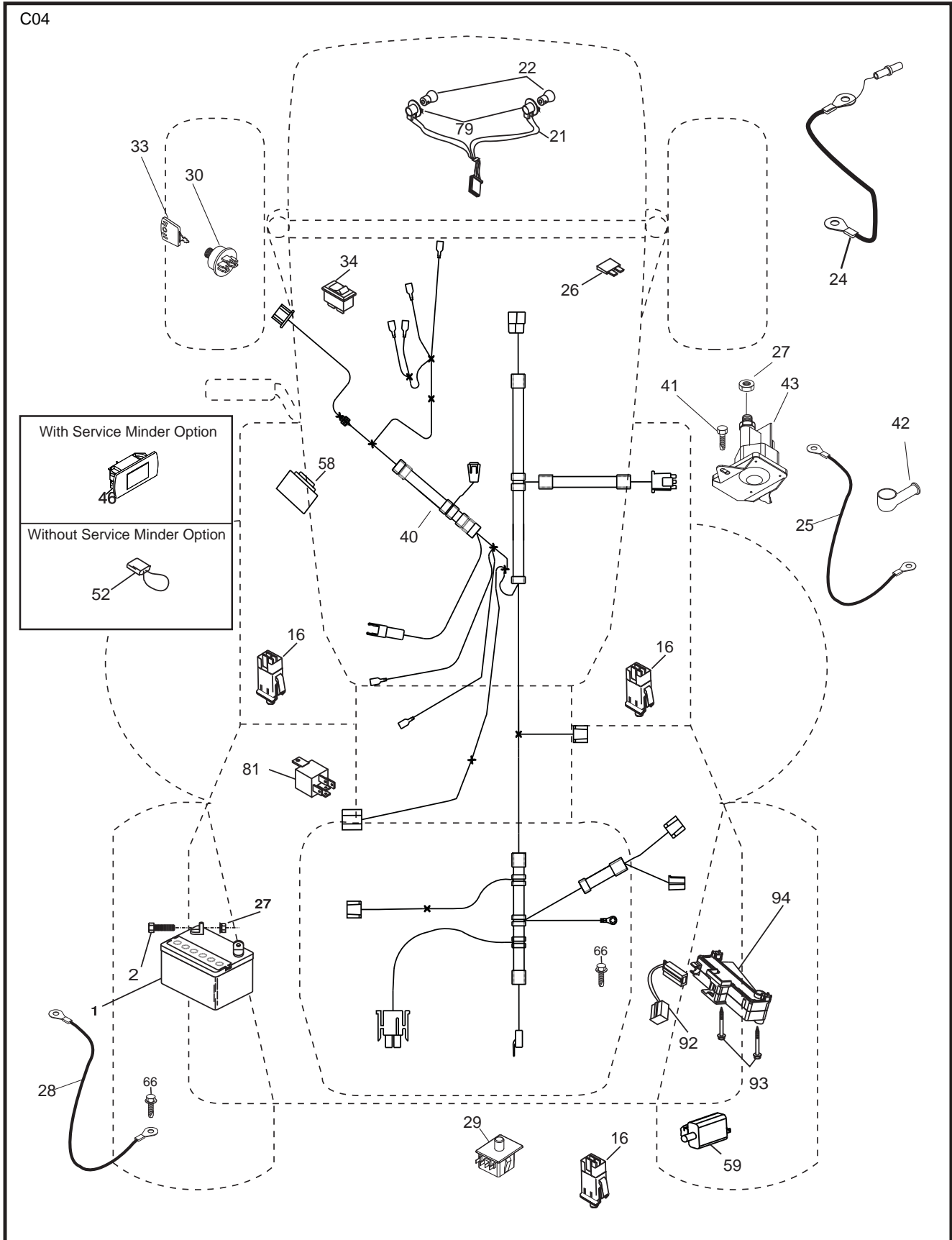

**TRACTOR -- MODEL NO. M175H38RB (96061033602), PRODUCT NO. 960 61 03-36
ELECTRICAL 32**

KEY NO.	PART NO.	DESCRIPTION
1	532 16 34-65	Battery
2	874 76 04-12	Bolt Hex Hd 1/4-20 unc x 3/4
16	532 17 61-38	Switch Interlock
21	532 18 37-59	Harness Asm Light w/4152J
22	532 00 41-52	Bulb Light #1156
24	532 16 59-87	Cable Battery Crd 56" Red
25	532 42 12-99	Cable Starter 6 Ga. 11" Red
26	532 17 51-58	Fuse
27	873 51 04-00	Nut Keps Hex 1/4-20 unc
28	532 12 77-25	Cable Ground 6 Ga. 18" Black
29	532 19 27-49	Switch Seat
30	532 19 33-50	Switch Ignition
33	532 41 19-33	Key/Chain
34	532 11 07-12	Switch Light/Reset B/B/Red
40	532 40 36-20	Harness Ignition
41	871 11 04-08	Bolt Flk Fin Hex 1/4-20 unc x 1/2
42	532 13 15-63	Cover Terminal Red
43	532 19 25-07	Solenoid
46	532 40 17-63	Gauge Service Reminder/Hrmtr Rect
58	532 16 94-19	Buzzer Crd
59	532 18 03-79	Switch FBI CRD
66	817 49 06-08	Screw Thdrol 3/8-16 x 1/2 Ty-Tt
79	532 17 52-42	Socket Asm Bulb Twistlock
81	532 10 97-48	Relay Asm
92	532 19 66-15	Harness Pigtail Console ROS
93	532 19 25-40	Screw Plastite 10-14 x 2.0
94	532 19 18-34	Module Reverse ROS

NOTE: All component dimensions given in U.S. inches
1 inch = 25.4 mm

TRACTOR -- MODEL NO. M175H38RB (96061033602), PRODUCT NO. 960 61 03-36
CHASSIS AND ENCLOSURES **39**

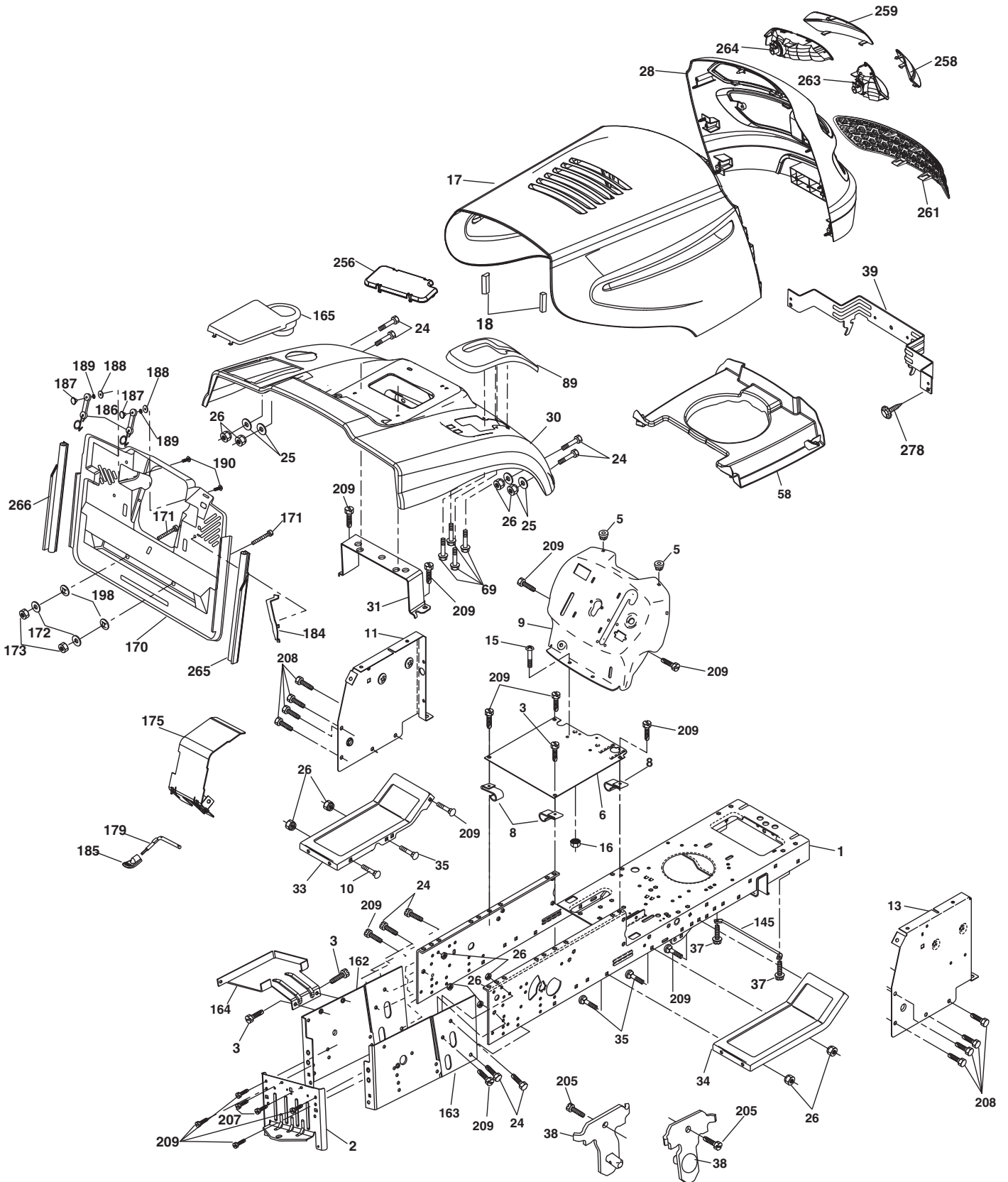

chassis-CRD_Elite SV Pro_1_r1

**TRACTOR -- MODEL NO. M175H38RB (96061033602), PRODUCT NO. 960 61 03-36
CHASSIS AND ENCLOSURES 39**

KEY NO.	PART NO.	DESCRIPTION	KEY NO.	PART NO.	DESCRIPTION
1	532 17 46-20	Chassis	165	532 18 13-56	Cover Battery
2	532 18 03-84	Drawbar	170	532 19 94-88	Backplate CRD
3	817 06 06-12	Screw 3/8-16 x 3/4	171	872 14 06-20	Bolt Rdhd Sqnk 3/8-16 x 2-1/2 Gr. 5
5	532 15 52-72	Bumper Hood/Dash	172	819 13 20-16	Washer 13/32 x 1-1/4 x 16 Ga.
6	532 18 44-19	Saddle	173	873 51 06-00	Nut, Keps Hex 3/8-16 unc
8	532 12 64-71	Clip Insulator 13/32 Mtg. Hole	175	532 18 82-03	Door Trap
9	532 40 51-33	Dash	179	532 18 82-02	Rod Pivot FBI CRD
10	872 14 06-08	Bolt, Carriage 3/8-16 x 3/4	184	532 17 46-62	Bracket Actuator Bagger CRD
11	532 17 49-96	Panel, Dash, LH	185	532 44 14-16	Knob Rod Brake Parking
13	532 18 69-52	Panel, Asm. Dash RH	186	532 16 07-93	Latch Asm Mulch/Bagger
15	874 18 05-12	Screw, Machine, Truss Head 5/16-18 unc x 3/4	187	532 12 50-04	Nut Weld
16	873 51 05-00	Nut	188	819 06 12-16	Washer #10
17	532 19 45-88	Hood	189	810 07 10-00	Washer Lock #10
18	532 18 49-21	Bumper Hood	190	871 08 10-10	Screw Pan Hd Phillip 10-24 x 5/8
24	874 78 06-16	Bolt	198	532 16 89-37	Nut, Push
25	819 13 13-12	Washer 13/32 x 13/16 x 12 Ga.	205	817 49 06-08	Screw Thdrol 3/8-16 x 1/2
26	873 80 06-00	Nut	207	817 67 05-08	Screw Thdrol 5/16-18 x 1/2
28	532 18 97-48	Grille	208	817 67 06-08	Screw Thdrol 3/8-16 x 1/2
30	532 19 73-64	Fender	209	817 00 06-12	Screw Hex Wsh Thdrol 3/8-16
31	532 16 51-56	Bracket, Fender Support	256	532 18 13-61	Cover Fender Rack
33	532 18 25-07	Footrest, L.H.	258	532 18 97-55	Lens Grille RH
34	532 18 25-08	Footrest, R.H.	259	532 18 97-54	Lens Grille LH
35	872 11 06-06	Bolt	261	532 18 97-53	Insert Grille
37	817 49 05-08	Screw Thdrol 5/16-18 x 1/2 TYT	263	532 18 38-33	Bezel Grille RH
38	532 18 17-48	Bracket Asm Pivot Mower Rear	264	532 18 38-32	Bezel Grille LH
39	532 40 78-07	Bracket Pivot	265	532 18 57-04	Seal Side RH Bagger
58	532 18 43-22	Duct Intake	266	532 18 57-03	Seal Side LH Bagger
69	532 14 24-32	Screw Hx Wsh Hi-Lo 1/4-1/2	278	532 41 63-58	Screw #10 x 0.750 BOS Thread
89	532 19 73-66	Console Crd Auto	--	532 00 54-79	Plug, Button
145	532 40 91-67	Rod Pivot Chassis/Hood	--	532 18 78-01	Plug Switch Light
162	532 18 03-82	Bracket Exten Chassis LH CRD			
163	532 18 03-83	Bracket Exten Chassis RH CRD			
164	532 16 56-05	Support Battery CRD			

NOTE: All component dimensions given in U.S. inches
1 inch = 25.4 mm

**TRACTOR -- MODEL NO. M175H38RB (96061033602), PRODUCT NO. 960 61 03-36
DRIVE 40**

KEY NO.	PART NO.	DESCRIPTION	KEY NO.	PART NO.	DESCRIPTION
1	---	Transaxle Hydro Gear 321-0510 (170061)(Order parts from transaxle manufacturer)	96	532 12 47-88	Spring, Retainer 1"
8	532 19 27-06	Rod, Shift Fender Adjust Lt	112	819 09 12-10	Washer 9/32 x 3/4 x 10 Ga.
9	532 40 85-79	Clutch Noram	120	873 90 06-00	Nut Lock Flg. 3/8-16 unc
10	876 02 04-16	Pin, Cotter 1/8 x 1	150	532 16 58-50	Bushing, Bellcrank Grnd Dr
14	810 04 04-00	Washer, Lock Hvy Helical	151	819 13 32-10	Washer 13/32 x 2 x 10 Ga.
15	874 49 05-44	Bolt Hex FGHD 5/16-18 x Gr. 5	156	532 16 60-02	Washer Srrted 5/16 ID x 1.125
16	873 80 05-00	Nut Lock Hex W/Ins 5/16-18 unc	158	532 43 74-58	Bracket Shift Mount
19	873 80 06-00	Nut Lock Hex w/Insert 3/8-16 unc	159	532 44 43-04	Hub Shift
21	532 41 14-00	Knob	161	872 14 04-06	Bolt Rdhd Sqnk 1/4-20 x 3/4 Gr. 5
22	532 17 56-07	Rod, Brake	162	873 68 04-00	Nut Crownlock 1/4-20 unc
24	873 35 06-00	Nut	163	874 78 04-16	Bolt Hex Fin 1/4-20 unc x 1 Gr 5
25	532 19 20-36	Spring, Rod, Brake	165	532 43 82-50	Bracket Pivot Lever
27	876 02 04-12	Pin, Cotter 1/8 x 3/4	166	817 49 05-10	Screw 5/16-18 x 5/8
28	532 17 57-65	Rod, Parking Brake	167	532 16 55-88	Bracket Support Shift CRD
29	532 07 16-73	Cap, Parking Brake	168	532 16 54-92	Bolt Shoulder 5/16-18 x .561
30	532 16 95-92	Bracket, Mfg. Transaxle	169	532 16 55-80	Plate Fastening Lt
34	532 17 55-78	Shaft, Asm Pedal Foot CRD	171	817 49 06-08	Screw Thdrol 3/8-16 x 1/2 Ty-Tt
35	532 12 01-83	Bearing, Nylon	172	532 17 02-71	Shaft Asm Shifter Frt CRD
36	819 21 16-16	Washer 21/32 x 1 x 16 Ga.	177	532 16 59-32	Keeper Flat Idler 3.06" CRD
37	532 12 49-63	Pin, Roll 3/16 x 1"	181	532 18 02-11	Bracket Idler Ground Drive CRD
38	532 16 59-36	Pulley Flat Composite 3.06"	182	532 18 26-82	Keeper Belt 2.5" Od V-Idler CRD
39	874 76 06-44	Bolt Fin Hex 3/8-16 unc x 2-3/4	183	532 19 95-34	Pulley V-Idler 2.50" Od CRD
40	532 12 49-65	Spacer, Split 395 x 59 Bzp	185	532 17 00-08	Link Shift
42	819 13 13-12	Washer 13/32 x 13/16 x 12 Ga.	186	532 16 56-14	Hub Tapered Round CRD
43	819 11 10-12	Washer 11/32 x 5/8 x 12 Ga.	187	817 58 05-20	Screw Thdrol 5/16-18 x 1.25
47	532 12 77-83	Pulley, Idler, V Groove Plasitc	197	532 16 96-13	Nyliner Snap-In 5/8
48	532 15 44-07	Bellcrank Clutch Grnd Drv	199	532 16 96-12	Bolt Shoulder 5/16-18 unc
49	532 12 32-05	Retainer, Belt Style Spring	200	872 14 05-08	Bolt RDHD SQNK 5/16-18 x 1
50	872 11 06-12	Bolt 3/8-16 x 1-1/2 Gr. 5	203	871 17 07-80	Bolt Hex 7/16-20 x 5
51	873 68 06-00	Nut, Crownlock 3/8-16 unc	207	532 16 98-45	Washer Nylon Rear
52	873 68 05-00	Nut Crownlock 5/16-18	214	532 17 56-09	Shaft Asm. Brake
53	532 19 96-52	Link, Clutch 7.66	215	532 17 56-52	Rod Brake Hydro
55	532 10 57-09	Spring, Return, Clutch	252	819 13 16-16	Washer 13/32 x 1 x 16 Ga.
56	817 06 06-20	Screw 3/8-16 x 1-1/4	253	532 17 50-28	Bracket Cable Chassis
57	532 17 01-40	V-Belt Kev 112" 0650 CRD	254	817 00 06-16	Screw 3/8-16 x 1
62	532 12 48-72	Cover, Pedal	255	532 17 56-08	Brace Shaft Brake Mtg.
65	810 04 07-00	Washer	258	532 17 80-62	Clip Retainer
66	532 15 47-78	Keeper, Belt Engine F-Proof	259	532 18 02-12	Bracket Pulley
71	532 16 91-83	Strap, Torque, Lh	261	532 13 14-94	Pulley Idler
73	532 16 91-82	Strap, Torque, Rh	262	872 11 06-22	Bolt Rdhd 3/8-16 unc x 2-3/4 Gr. 5
74	532 13 70-57	Spacer, Split	263	817 00 06-12	Screw 3/8-16 x 3/4
75	532 12 17-49	Washer 25/32 x 1-1/4 x 16 Ga.	264	532 43 11-74	Bracket Idler Chass.
76	812 00 00-01	Ring, E	265	532 42 69-13	Spacer
77	532 12 35-83	Key, Square	266	532 18 20-61	Shield Idler Mower
78	532 12 17-48	Washer 25/32 x 1-5/8 x 16 Ga.	292	532 40 02-71	Spacer Noram
81	532 17 00-06	Asm, Shaft,Cross Rear	293	872 14 06-28	Bolt Rdhd Sqnk 3/8-16 x 3-1/2
82	532 16 57-11	Spring, Torsion	294	532 19 70-33	Nut Jam 3/8-16
83	819 17 12-16	Washer 17/32 x 3/4 x 16 Ga.	295	532 17 91-14	Pulley Idler Composite
84	532 17 00-07	Link, Transaxle	297	817 49 06-10	Screw Hxwsh Thdr 3/8-16 x 5/8
95	532 17 00-15	Control Asm Bypass Hydro			

NOTE: All component dimensions given in U.S. inches
1 inch = 25.4 mm

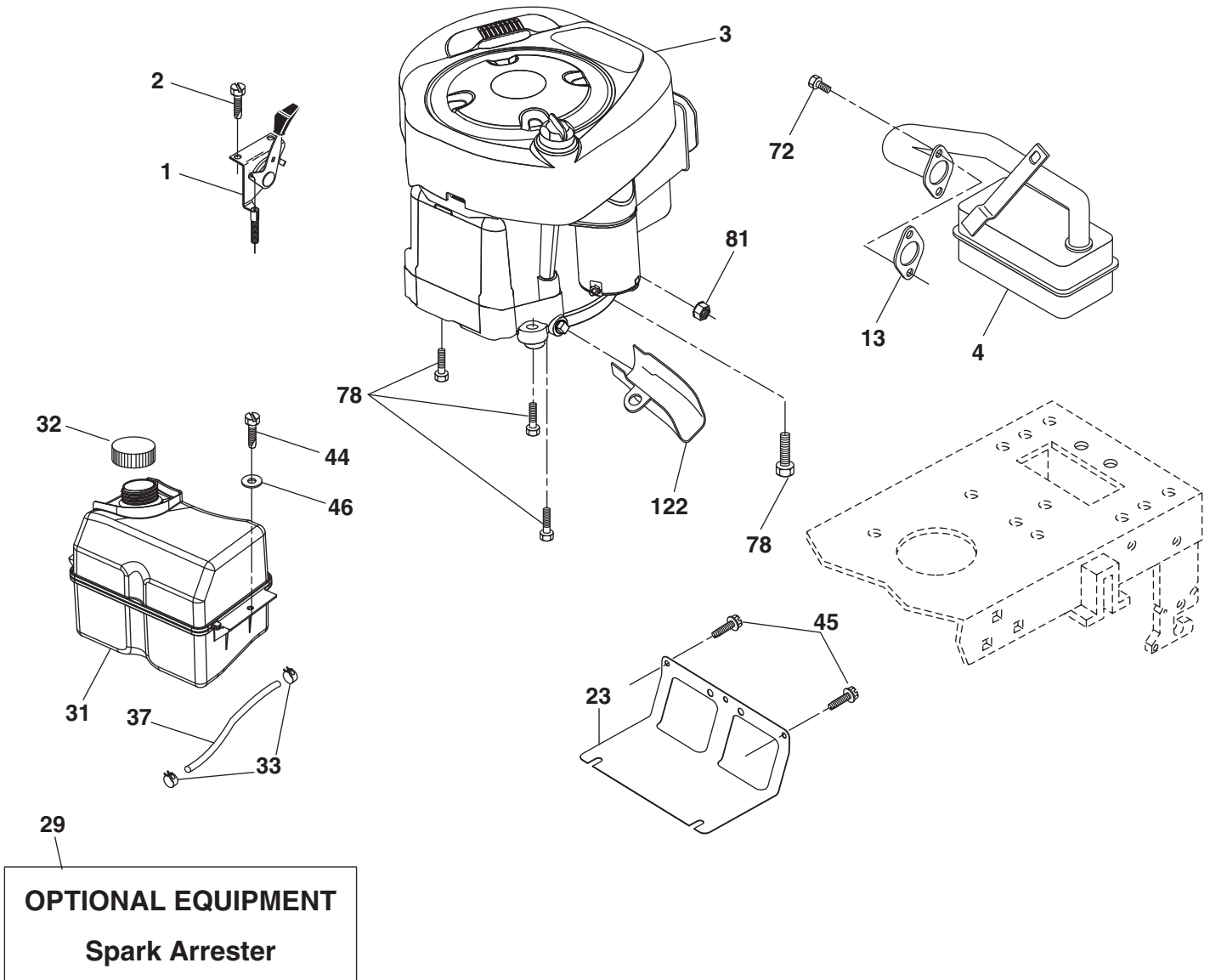

engine-CRD_bs_26

**TRACTOR - - MODEL NO. M175H38RB (96061033602), PRODUCT NO. 960 61 03-36
ENGINE 24**

KEY NO.	PART NO.	DESCRIPTION
1	532 41 17-24	Control Throt/Ck
2	817 72 04-08	Screw Hex Thd Cut 1/4-20 x 1/2
3	- - - - -	Engine B&S Model 31G777-1597-G5 (443665)(Order parts from engine manufacturer)
4	532 13 73-52	Muffler
13	532 16 52-91	Gasket Muffler
23	532 16 98-37	Shield Brn/Dbr Guard
29	532 13 71-80	Kit Spark Arrestor (Flat Scrn)
31	532 40 75-51	Tank Fuel
32	532 43 02-20	Cap Asm Fuel Top
33	532 12 34-87	Clamp Hose Blk
37	532 13 70-40	Line Fuel
44	817 67 04-12	Screw Hexwsh Thdrol 1/4-20 x 3/4
45	817 00 06-12	Screw Hexwsh Thdr 3/8-16 x 3/4
46	819 09 14-16	Washer 9/32 x 7/8 x 16 Ga.
72	532 19 23-34	Screw Socket Hd 5/16-18 x .75
78	817 06 06-20	Screw 3/8-16 x 1/4
81	873 51 04-00	Nut Keps Hex 1/4-20 unc
122	532 42 19-22	Extension Drain Oil

NOTE: All component dimensions given in U.S. inches
1 inch = 25.4 mm

Engine Power Rating Information

The gross power rating for individual gas engine models is labeled in accordance with SAE (Society of Automotive Engineers) code J1940 (Small Engine Power & Torque Rating Procedure), and rating performance has been obtained and corrected in accordance with SAE J1995 (Revision 2002-05). Torque values are derived at 3060 RPM; horsepower values are derived at 3600 RPM. Actual gross engine power will be lower and is affected by, among other things, ambient operating conditions and engine-to-engine variability. Given both the wide array of products on which engines are placed and the variety of environmental issues applicable to operating the equipment, the gas engine will not develop the rated gross power when used in a given piece of power equipment (actual "on-site" or net power). This difference is due to a variety of factors including, but not limited to, accessories (air cleaner, exhaust, charging, cooling, carburetor, fuel pump, etc.), application limitations, ambient operating conditions (temperature, humidity, altitude), and engine-to-engine variability. Due to manufacturing and capacity limitations, Briggs & Stratton may substitute an engine of higher rated power for this Series engine.

TRACTOR -- MODEL NO. M175H38RB (96061033602), PRODUCT NO. 960 61 03-36
STEERING ASSEMBLY **41**

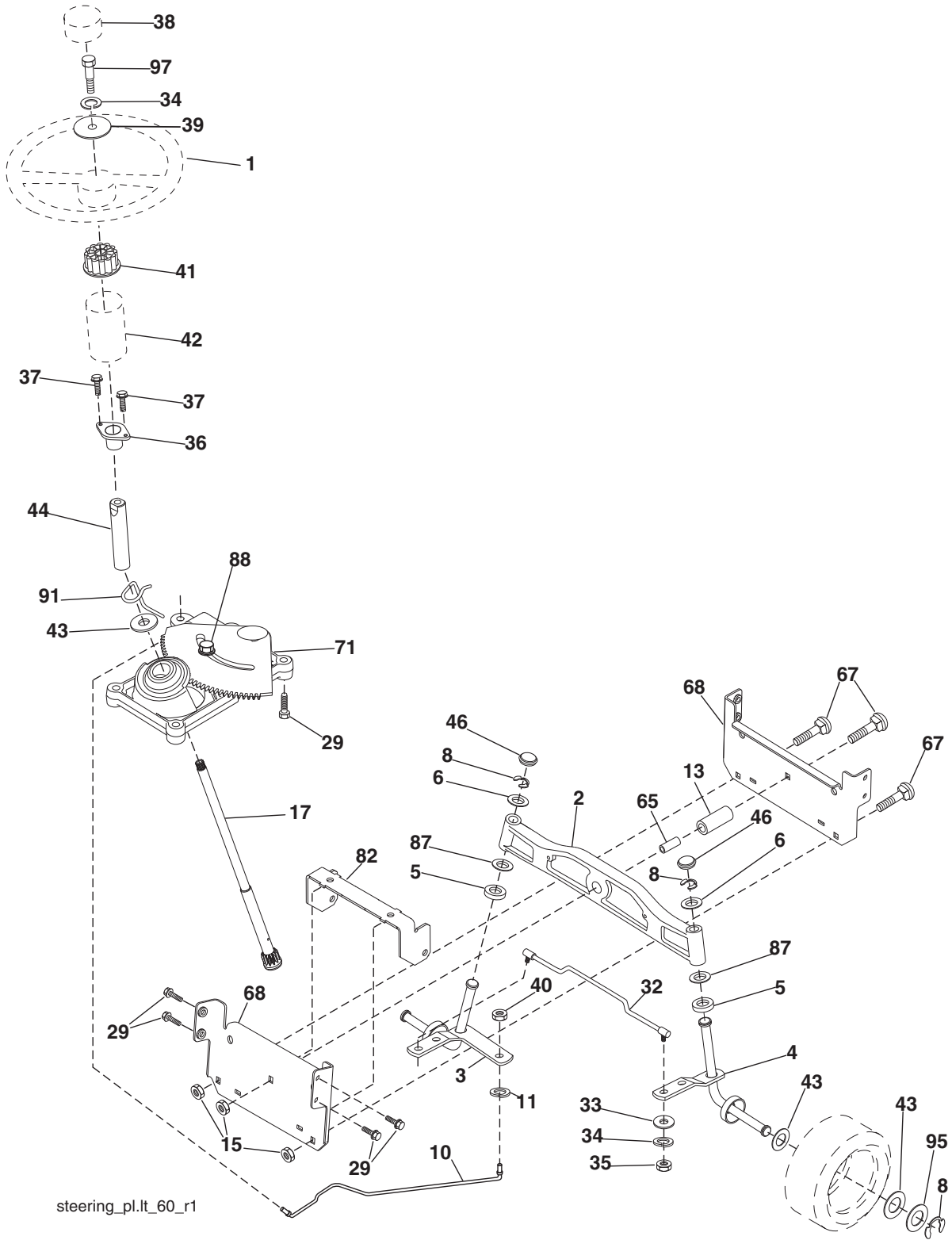

steering_pl.lt_60_r1

**TRACTOR -- MODEL NO. M175H38RB (96061033602), PRODUCT NO. 960 61 03-36
STEERING ASSEMBLY 41**

KEY NO.	PART NO.	DESCRIPTION
1	532 42 45-51	Steering Wheel
2	532 18 47-06	Front Axle Assembly
3	532 16 98-40	Spindle Assembly, LH
4	532 16 98-39	Spindle Assembly, RH
5	532 12 49-31	Bearing, Race, Thrust, Hardened
6	532 12 17-48	Washer 25/32 x 1-5/8 x 16 Ga.
8	812 00 00-29	Ring, Clip
10	532 17 51-21	Link, Drag
11	810 04 06-00	Washer, Lock
13	532 13 65-18	Spacer Axle
15	873 90 06-00	Nut Flange Lock
17	532 19 07-53	Shaft Assembly, Steering
29	817 00 06-12	Screw 3/8-16 x 3/4
32	532 17 01-62	Rod, Tie
33	819 11 12-16	Washer 11/32 x 3/4 x 16 Ga.
34	810 04 05-00	Washer Lock Hvy Hlcl Spr 5/16
35	873 54 05-00	Crownlock Nut 5/16-24 unf
36	532 15 50-99	Bushing, Steering
37	532 15 29-27	Screw TT #10-32 x 5 x 3/8 Flange
38	532 44 15-06	Cap Wheel Steering
39	819 11 38-12	Washer 11/32 ID x 2-3/8 OD 12 Ga.
40	873 54 06-00	Nut Crownlock 3/8-24
41	532 18 67-37	Adaptor, Steering Wheel
42	532 16 96-33	Boot, Steering Dash P/L Mtl
43	532 12 17-49	Washer 25/32 x 1-1/4 x 16 Ga.
44	532 19 07-52	Extension Steering
46	532 12 12-32	Cap, Spindle
65	532 41 47-36	Spacer Axle Brace
67	872 11 06-18	Bolt Rdhd Sq 3/8-16 x 2-1/4
68	532 16 98-27	Brace Axle
71	532 17 51-46	Steering Asm.
82	532 19 99-78	Bracket Susp. Chassis Front
87	532 17 39-66	Washer Flat .781 x 1-1/2 x .14
88	532 17 51-18	Bolt Shoulder 7/16-20 unc
91	532 17 55-53	Clip Steering
95	532 18 89-67	Washer Hardened .739 x 1.637 x 060
97	532 42 89-82	Bolt 5/16-18 x 4 w/Patch

NOTE: All component dimensions given in U.S. inches
1 inch = 25.4 mm

TRACTOR -- MODEL NO. M175H38RB (96061033602), PRODUCT NO. 960 61 03-36
MOWER DECK 44

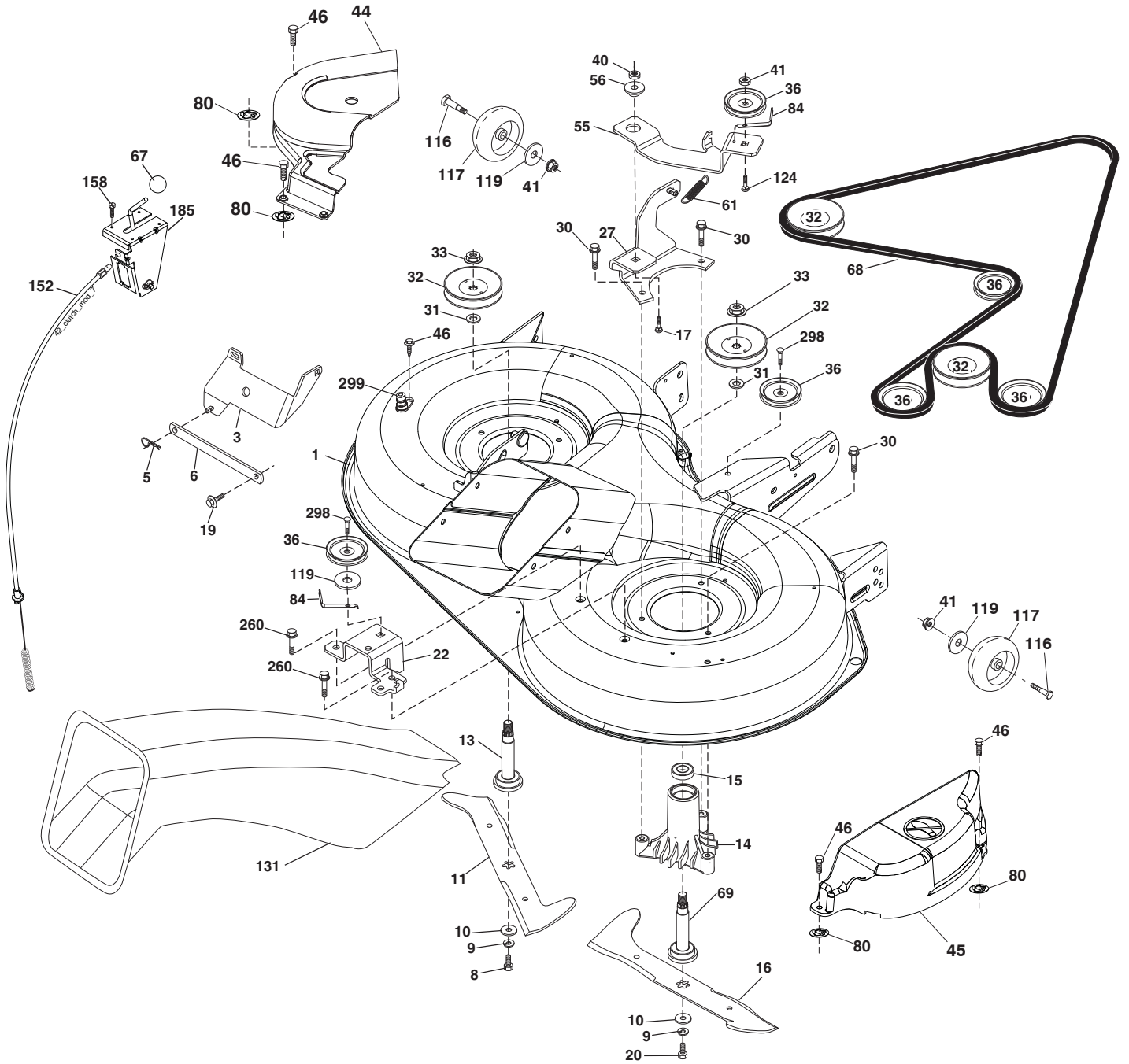

Deck-CRD_97cm_Elect_1_r5

**TRACTOR -- MODEL NO. M175H38RB (96061033602), PRODUCT NO. 960 61 03-36
MOWER DECK 44**

KEY NO.	PART NO.	DESCRIPTION	KEY NO.	PART NO.	DESCRIPTION
1	532 42 91-21	Housing Asm. Mower	61	532 19 94-86	Spring Tension
3	532 43 18-64	Bracket Asm. S-Bar Chass	67	532 17 15-98	Knob
5	532 12 46-70	Retainer Spring	68	532 42 95-32	Belt Mower
6	532 16 55-57	Bar Sway	69	532 16 54-82	Shaft Asm w/Lwr Brg RH Thd
8	532 18 17-12	Bolt 3/8-24 x 1.25 Gr. 8 Patched	80	532 42 30-62	Palnut 1/4
9	810 03 06-00	Washer Lock Hvy 3/8 Unplated	84	532 15 60-85	Keeper Belt Idler
10	532 14 02-96	Washer Hard Blade	116	532 19 34-06	Bolt Shoulder 3/8-16 x 3-5/8 Gr. 5
11	532 42 79-84	Blade 3-1 LH	117	532 17 48-73	Wheel Gage
13	532 13 76-45	Shaft Asm. w/Lower Bearing	119	819 13 20-12	Washer 13/32 x 1-1/4 x 12 Ga.
14	532 12 87-74	Housing Mandrel Vented (Machd)	124	872 11 06-12	Bolt Carr Sh 3/8-16 x 1-1/2 Gr. 5
15	532 11 04-85	Bearing Ball Mandrel	131	532 16 56-61	Chute Bagger CRD 92cm
16	532 42 79-85	Blade 3-1 RH	152	532 17 60-74	Cable Clutch
17	872 14 06-10	Bolt Carriage 3/8-16 x 1-1/4	158	817 72 04-08	Screw 1/4-20 x 1/2
19	532 13 28-27	Bolt Shoulder 5/16-18 Thd Form	185	532 18 82-34	Head Asm Cable Clutch
20	532 18 17-13	Bolt 3/8-24 x 1.25 Gr. 8 Ptch	260	817 67 06-08	Screw Thdrol 3/8-16 x 1/2
22	532 43 11-69	Bracket Idler Sprt RR	298	817 49 06-28	Nut Lock Flg 3/8-16 unc
27	532 42 79-81	Bracket Asm. Susp RR	299	532 41 55-98	Port Washout
30	532 17 39-84	Screw Thd Rolling Dod.PT Hex	--	532 18 18-57	Mandrel Assembly (Includes hous- ing, shaft assembly, and bearing only - pulley/nut/washer and blade bolt/washers not included)
31	532 18 76-90	Washer Spacer Mower Vented	--	532 18 18-58	Mandrel Asm CRD LH Threads VC
32	532 15 35-32	Mandrel Pulleys	--	532 43 34-84	Replacement Mower Complete
33	532 40 02-34	Nut Flg Top Lock			
36	532 14 67-63	Pulley Idler V-Groove Dim 4.25			
40	873 68 06-00	Nut Crownlock 3/8-16 unc			
41	873 90 06-00	Nut Flangelock 3/8-16 unc			
44	532 43 11-70	Cover Mandrel LH			
45	532 43 89-68	Cover Mandrel RH			
46	532 13 77-29	Screw			
55	532 19 94-98	Arm Idler			
56	532 16 57-23	Spacer Retainer			

NOTE: All component dimensions given in U.S. inches
1 inch = 25.4 mm

TRACTOR -- MODEL NO. M175H38RB (96061033602), PRODUCT NO. 960 61 03-36
MOWER LIFT 45

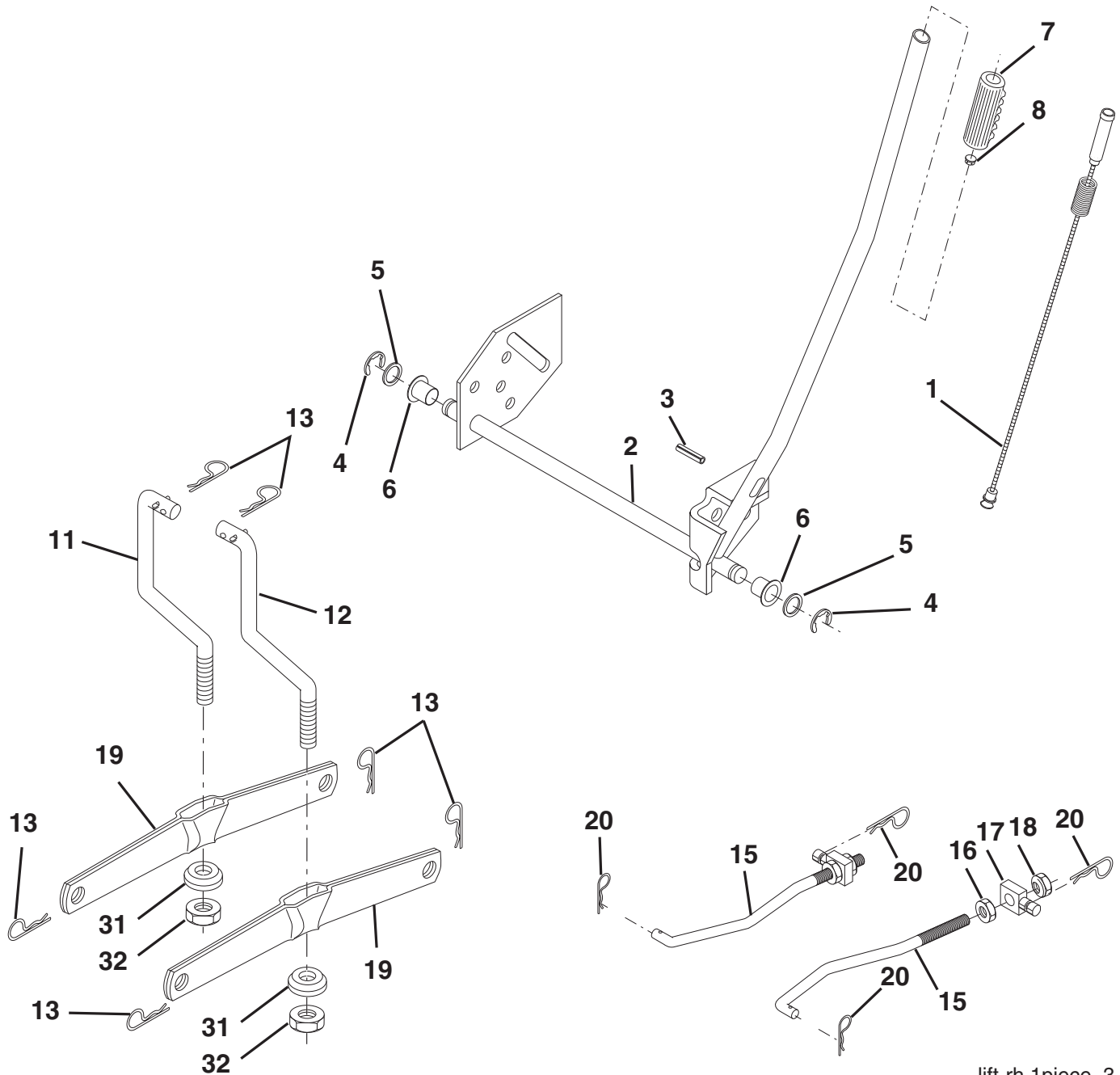

lift-rh.1piece_3

KEY NO.	PART NO.	DESCRIPTION
1	585 14 77-02	Plunger Asm. Lift LVR
2	585 14 76-02	Shaft Asm. Lift
3	532 18 88-22	Pin Groove
4	812 00 00-02	E Ring #5133-62
5	819 21 16-21	Washer 21/32 x 1 x 21 Ga.
6	532 12 01-83	Bearing Nylon
7	532 10 94-13	Grip Handle Bicycle
8	532 17 07-70	Button Plunger Yellow
11	532 13 98-65	Link Asm Lift L.H.
12	532 13 98-66	Link Asm Lift R.H.
13	532 12 46-70	Retainer Spring
15	532 17 32-88	Link Front

KEY NO.	PART NO.	DESCRIPTION
16	873 35 08-00	Nut Jam Hex 1/2-13 unc
17	532 17 56-89	Trunnion Blk Zinc
18	873 80 08-00	Nut Lock w/wsh 1/2-13 unc
19	532 13 98-68	Arm Suspension Mower
20	532 19 42-09	Retainer Spring
31	532 16 98-65	Bearing, Pvt. Lift.
32	873 54 06-00	Nut Crownlock 3/8-24

NOTE: All component dimensions given in U.S. inches
 1 inch = 25.4 mm

**TRACTOR -- MODEL NO. M175H38RB (96061033602), PRODUCT NO. 960 61 03-36
SEAT ASSEMBLY 42**

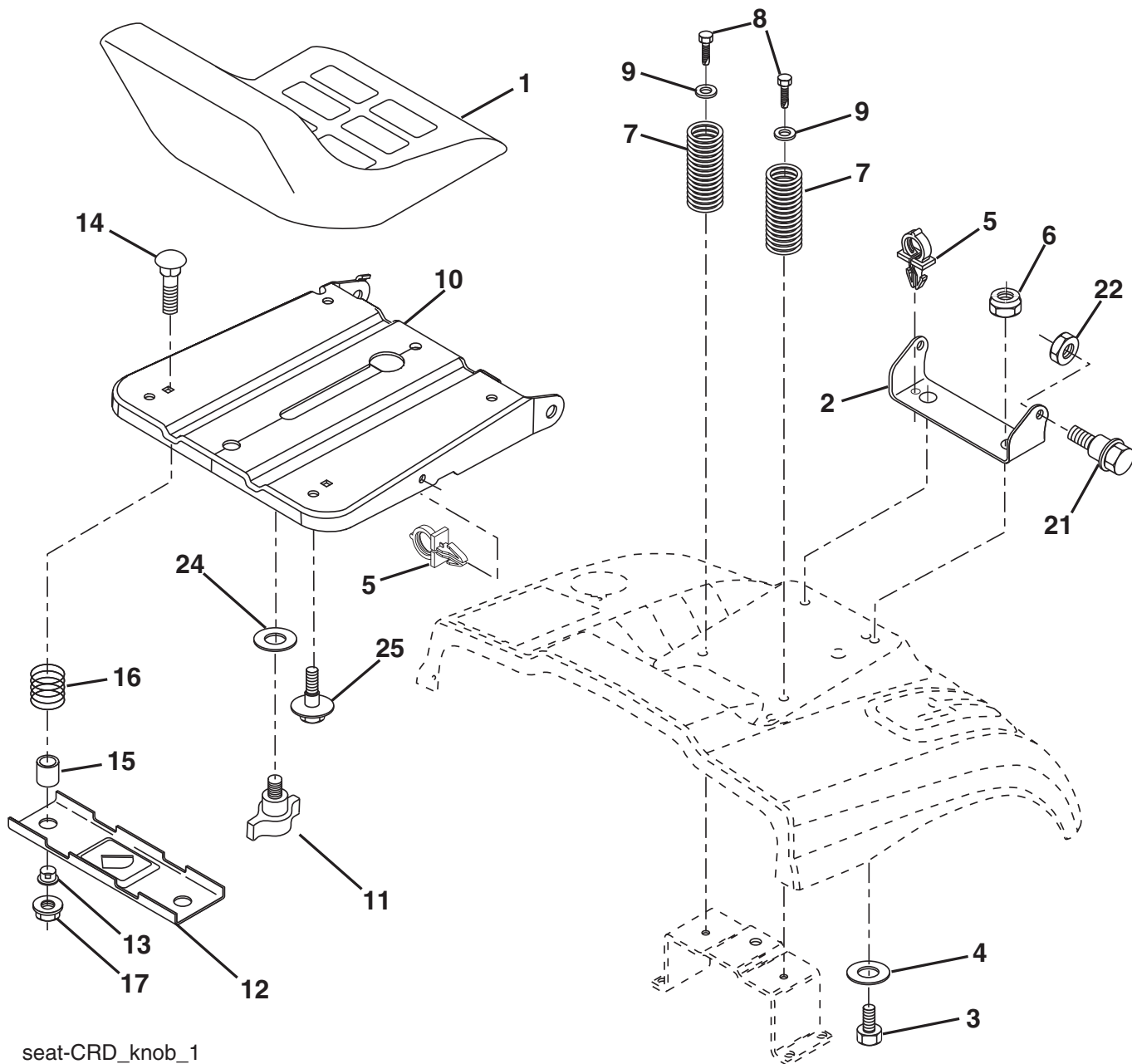

seat-CRD_knob_1

KEY NO.	PART NO.	DESCRIPTION
1	532 18 87-13	Seat
2	532 14 05-51	Bracket Pnt Pivot Seat (blk)
3	871 11 06-16	Bolt Fin Hex 3/8-16 x 1
4	819 13 16-10	Washer Flat 13/32 x 1 x 10 Ga.
5	532 14 50-06	Clip Push In Hinged
6	873 80 06-00	Nut Lock Hex W/Ins 3/8-16
7	532 12 41-81	Spring Seat Cprsn 2 250 Blk Zi
8	817 00 06-16	Screw 3/8-16 x 1.5
9	819 13 16-14	Washer 13/32 x 1 x 14 Ga.
10	532 19 55-30	Pan Pnt Seat (blk)
11	532 16 63-69	Knob Seat
12	532 17 46-48	Bracket Pnt Mounting Switch

KEY NO.	PART NO.	DESCRIPTION
13	532 12 12-48	Bushing Snap Blk Nyl 50 Id
14	872 05 04-12	Bolt Rdhd Sht Nk 1/4-20 x 1-1/2
15	532 13 43-00	Spacer Split
16	532 12 12-50	Spring Cprsn
17	532 12 39-76	Nut Lock 1/4 Lge Flg Gr. 5 Zinc
21	532 17 18-52	Bolt Shoulder 5/16-18 unc-2A
22	873 80 05-00	Nut Hex Lock w/Ins 5/16-18
24	819 17 19-12	Washer 17/32 x 1-3/16 x 12 Ga.
25	532 12 70-18	Bolt Shoulder 5/16-18 x .62

NOTE: All component dimensions given in U.S. inches.
1 inch = 25.4 mm

TRACTOR -- MODEL NO. M175H38RB (96061033602), PRODUCT NO. 960 61 03-36
BAGGER **46**

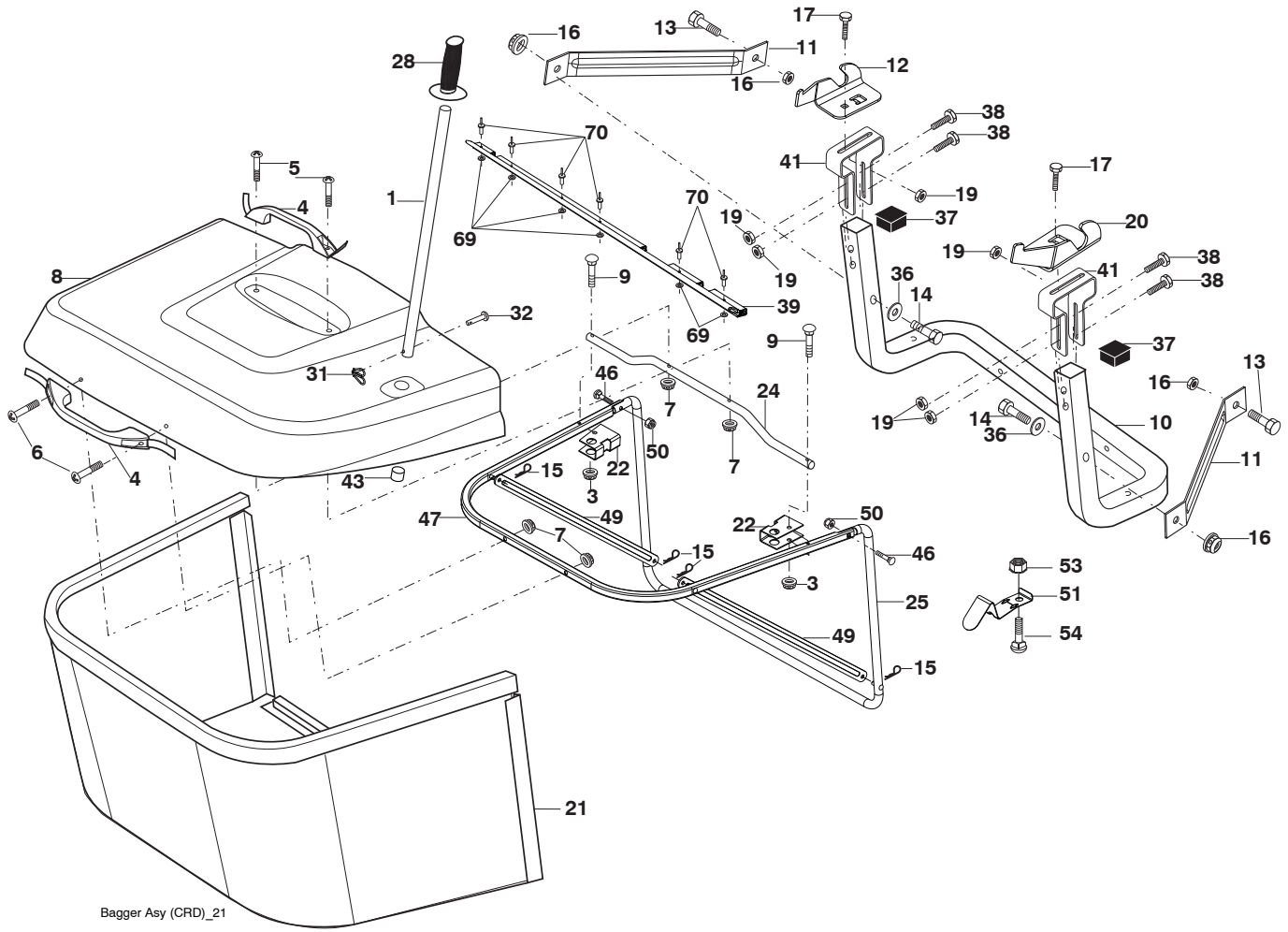

**TRACTOR -- MODEL NO. M175H38RB (96061033602), PRODUCT NO. 960 61 03-36
BAGGER 46**

KEY NO.	PART NO.	DESCRIPTION
1	532 42 86-10	Tube Handle Bagger CRD
3	532 12 39-76	Nut Lock 1/4 Lge Flg Gr. 5 Zinc
4	532 16 99-16	Handle Bagger w/Lvrs Blk CRD
5	874 98 10-24	Screw Pan Head #10-24 x 1.50
6	874 98 10-32	Screw Pan Hd
7	873 40 10-00	Nut Wiz Lock Hex Serr/Hd 10-24
8	532 43 69-33	Cover Bagger
9	872 14 04-18	Bolt Carr. 1/4-20 x 2.25d x Gr. 5
10	532 18 12-82	Tube Support Bagger CRD
11	532 16 57-19	Bracket Support Upper Bag CRD
12	532 18 88-48	Bracket Pivot LH
13	874 76 06-12	Bolt Fin Hex 3/8-16 unc x 3/4
14	874 52 06-36	BoltRDHD SQNK3/8-16x2-1/4 Gr.5
15	532 12 46-70	Retainer Spring
16	873 90 06-00	Nut Lock Flg 3/8-16 unc
17	872 14 05-06	BoltRdhd ShtSqnk5/16-18uncx3/4
19	873 90 05-00	Nut Lock Hex Flange 5/16-18
20	532 18 88-47	Bracket Pivot RH
21	532 40 61-80	Bag Asm CRD
22	532 42 82-36	Bracket Side Bagger CRD
24	532 16 57-83	Tube Pivot Bagger CRD
25	532 19 37-05	Tube Front Bagger CRD
28	532 16 57-87	Grip Handle
31	532 16 94-84	Retainer Clip
32	532 12 68-75	Rivet Rd Hd Drilled 3/8 Dia.
36	819 13 20-12	Washer 13/32 x 1-1/4 x 12 Ga.
37	532 44 48-48	Plug Support Bagger CRD
38	872 01 05-20	Bolt 5/16-18 x 2-1/2
39	532 41 62-57	Seal
41	532 43 27-55	Bracket Pnt Adj Pvt Bagger CRD
43	532 17 40-83	Plug Tubing End
46	872 11 05-10	Bolt carr 5/16-18 x 1-1/4 Gr. 5
47	532 19 37-04	Tube Upper
49	532 19 33-05	Bar Spreader
50	873 80 05-00	Nut Lock Hx w/Insert 5/16-18 unc
51	532 19 99-03	Latch Spring
53	873 51 04-00	Nut Keps Hex 1/4-20 unc
54	872 14 04-06	Bolt Rdhd Sqnk 1/4-20 x 3/4 Gr. 5
69	532 43 56-11	Washer .125
70	532 43 56-03	Rivet Pop .125 x .750

NOTE: All component dimensions given in U.S. inches
1 inch = 25.4 mm

