

ILLUSTRATED PARTS LIST

MFG ID NO. 96011023502

CUSTOMER CATALOG NO. M13597

PRODUCT NO. 960 11 02-35

**TRACTOR - - MODEL NO. M13597 (96011023502), PRODUCT NO. 960 11 02-35
DECALS 27**

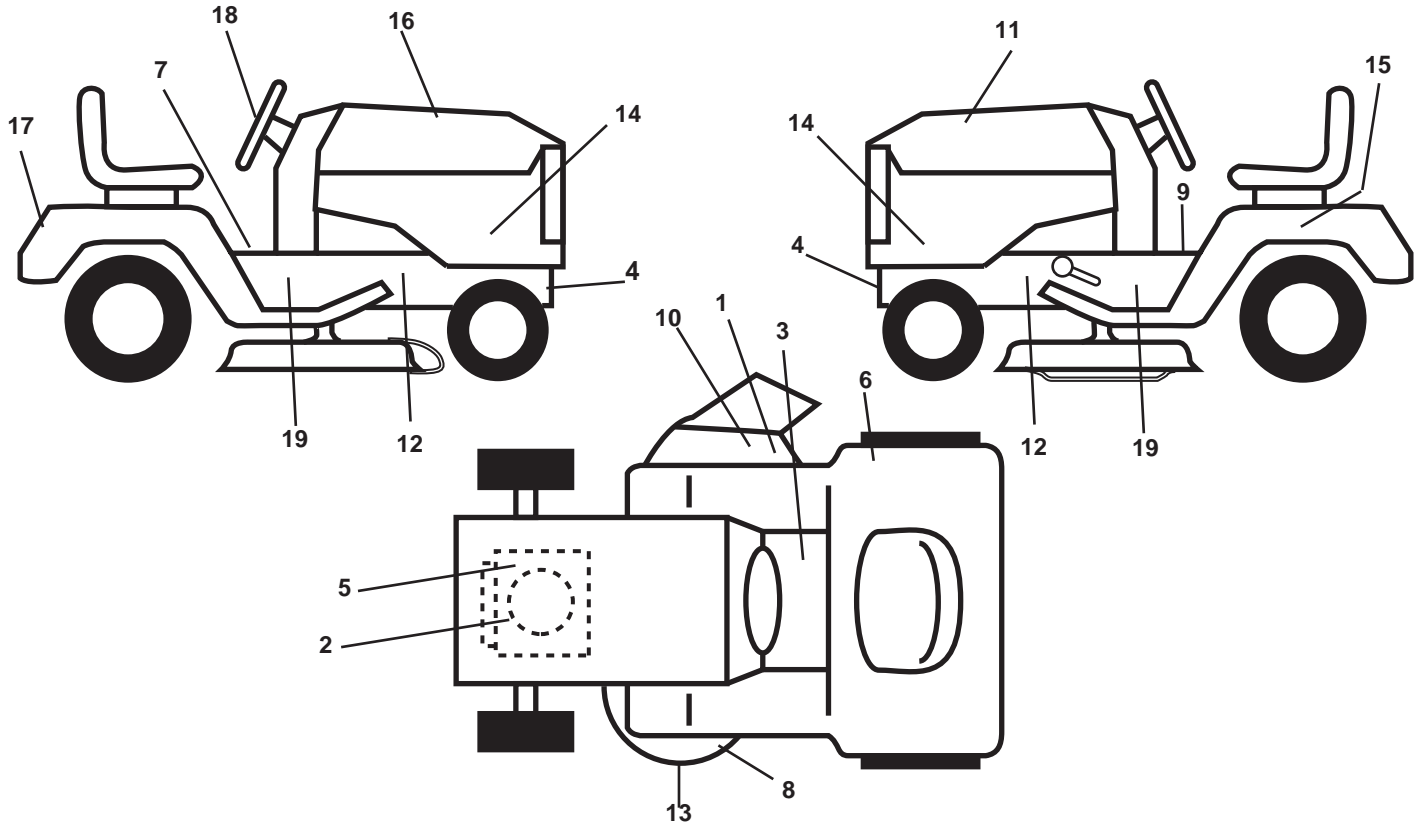

KEY NO.	PART NO.	DESCRIPTION
1	532 19 63-57	Decal, Deflect Wrn Cutfinger Sym
2	532 40 88-15	Decal, Engine HP
3	532 15 97-37	Decal, Brake/Clutch
4	532 15 97-36	Decal, Hot Muffler
5	532 19 68-41	Decal, Warning Engine Sym
6	532 18 04-32	Decal, DB/CE
7	532 40 03-89	Decal, Read Owner's Manual
8	532 19 43-02	Decal, V-Belt Sch.
9	532 14 08-37	Decal, Parking Brake
10	532 18 21-66	Decal, Cut Finger
11	532 40 82-59	Decal, Hood LH
12	532 40 11-46	Decal, Chassis

KEY NO.	PART NO.	DESCRIPTION
13	532 13 49-99	Decal, Enviro
14	532 40 82-61	Decal, Side Panel
15	532 14 50-05	Decal, Caution, Battery
16	532 40 82-58	Decal, Hood RH
17	532 40 82-60	Decal, Fender
18	532 40 82-02	Decal, Wheel Steering
19	532 19 68-42	Decal, Cutfinger
--	532 16 25-98	Decal, Drawbar
--	532 13 83-11	Decal, Handle Lft Height Adj.
--	532 18 10-90	Pad, Footrest RH
--	532 18 10-91	Pad, Footrest LH
--	532 40 09-01	Manual, Operator's, Euro

WHEELS & TIRES

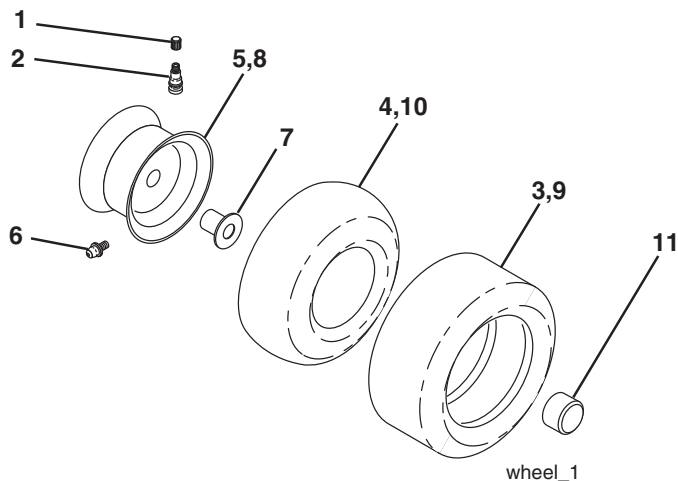

KEY NO.	PART NO.	DESCRIPTION
1	532 05 91-92	Cap, Tire valve
2	532 06 51-39	Stem, Valve
3	532 10 62-22	Tire, Front
4	532 05 99-04	Tube, Front (Service item only)
5	532 12 51-21	Rim assembly, 6" front
6	532 12 49-57	Fitting, Grease (Front wheel only)
7	532 12 49-59	Bearing, Flange (Front wheel only)
8	532 12 51-22	Rim assembly, 8" rear
9	532 12 46-35	Tire, Rear
10	532 12 49-26	Tube, Rear (Service item only)
11	532 17 50-39	Cap, Hub Axle
--	532 14 43-34	Sealant, Tire (10 oz. Tube)

NOTE: All component dimensions given in U.S. inches
1 inch = 25.4 mm

**TRACTOR - - MODEL NO. M13597 (96011023502), PRODUCT NO. 960 11 02-35
SCHEMATIC 38**

SCH03

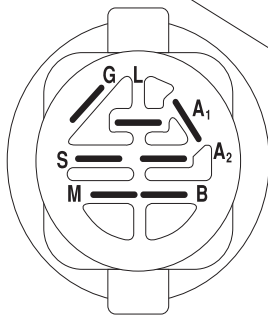
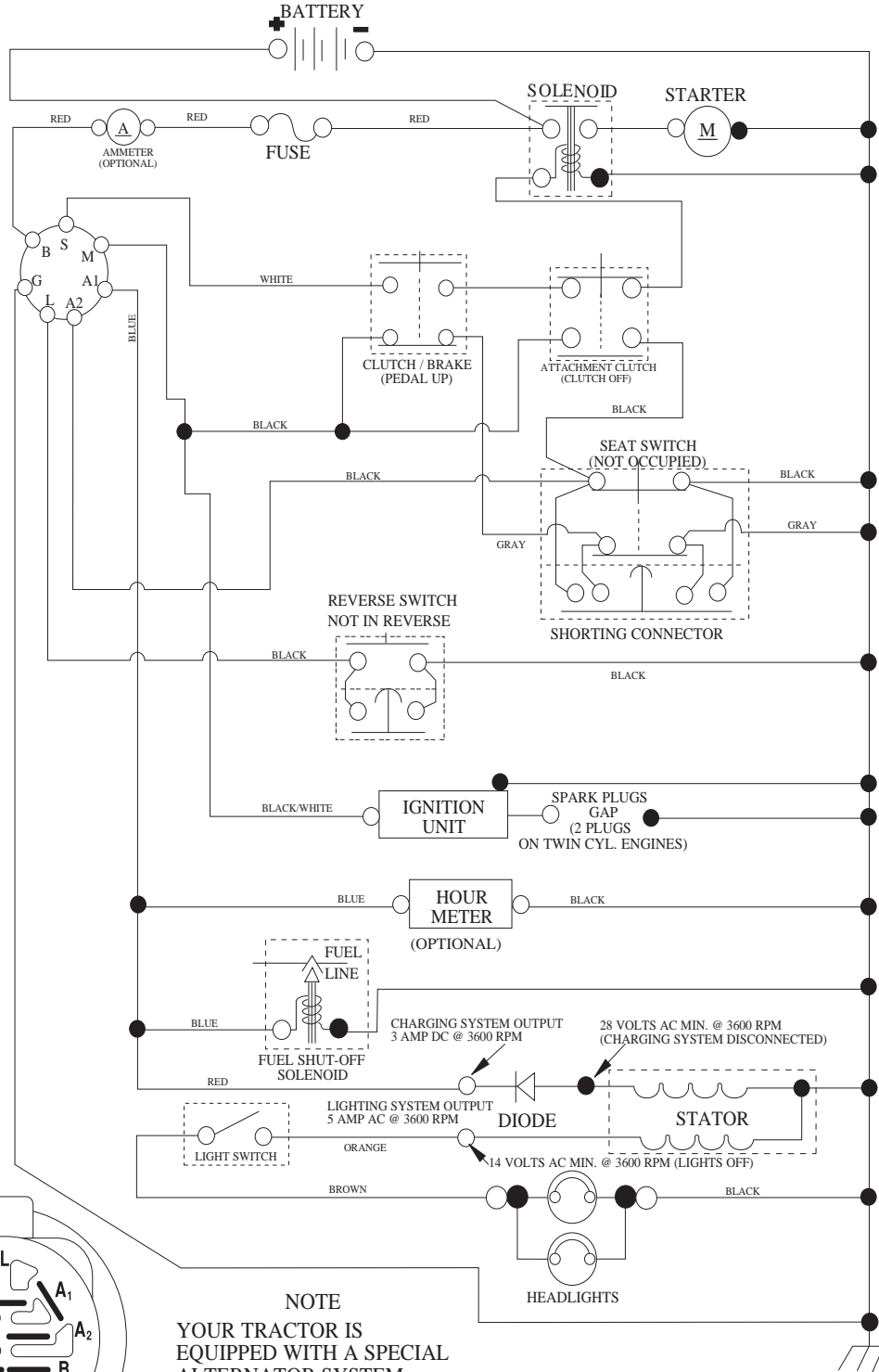

IGNITION SWITCH

POSITION	CIRCUIT	"MAKE"
OFF	M+G+A1	
RUN/OVERRIDE	B+A1	
RUN	B+A1	L+A2
START	B + S + A1	

NOTE
YOUR TRACTOR IS EQUIPPED WITH A SPECIAL ALTERNATOR SYSTEM. THE LIGHTS ARE NOT CONNECTED TO THE BATTERY, BUT HAVE THEIR OWN ELECTRICAL SOURCE. BECAUSE OF THIS, THE BRIGHTNESS OF THE LIGHTS WILL CHANGE WITH ENGINE SPEED. AT IDLE THE LIGHTS WILL DIM. AS THE ENGINE IS SPEEDED UP, THE LIGHTS WILL BECOME THEIR BRIGHTEST.



WIRING INSULATED CLIPS
NOTE: IF WIRING INSULATED CLIPS WERE REMOVED FOR SERVICING OF UNIT, THEY SHOULD BE RE-INSTALLED TO PROPERLY SECURE YOUR WIRING.

TRACTOR - - MODEL NO. M13597 (96011023502), PRODUCT NO. 960 11 02-35
ELECTRICAL **32**

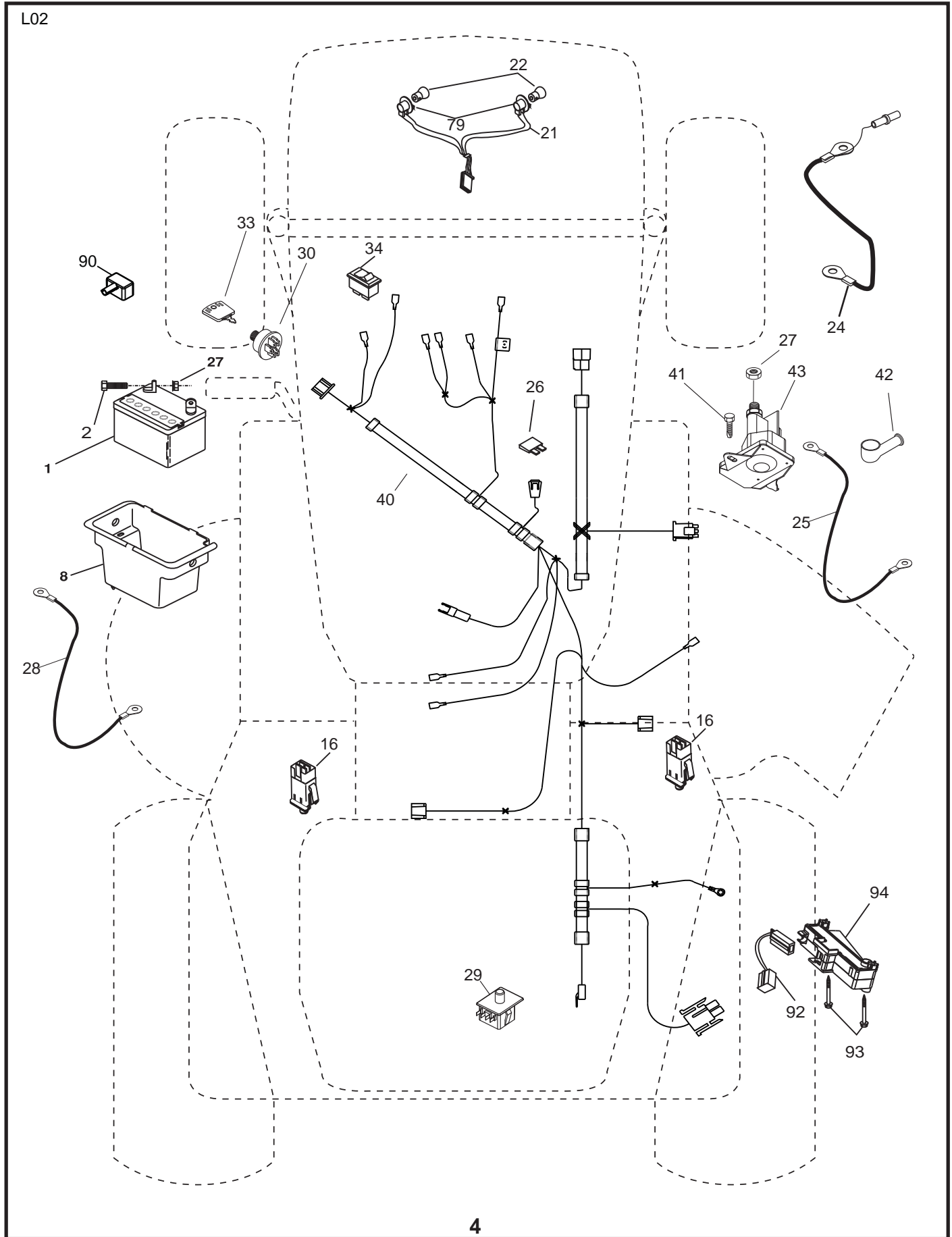

**TRACTOR - - MODEL NO. M13597 (96011023502), PRODUCT NO. 960 11 02-35
ELECTRICAL 32**

KEY NO.	PART NO.	DESCRIPTION
1	532 16 34-65	Battery 12 Volt 25 Amp
2	874 76 04-12	Bolt Hex Hd 1/4-20 Unc x 3/4
8	532 17 66-89	Battery Box
16	532 17 61-38	Switch Interlock Push-In
21	532 18 37-59	Harness Asm. Light w/4152J
22	532 00 41-52	Bulb
24	532 12 47-80	Cable Battery 6 Ga. 11"red
25	532 14 61-47	Cable Battery
26	532 17 51-58	Fuse
27	873 51 04-00	Nut Keps Hex 1/4-20 unc
28	532 12 47-73	Cable Ground 6 Ga. 12"black
29	532 19 27-49	Switch Seat
30	532 19 33-50	Switch Ign
33	532 41 19-35	Key/Chain
34	532 11 07-12	Switch light
40	532 19 74-28	Harness Ign
41	871 11 04-08	Bolt Blk Fin Hex 1/4-20
42	532 13 15-63	Cover Terminal Red
43	532 19 25-07	Solenoid
79	532 17 52-42	Socket Asm. Bulb
90	532 18 04-49	Cover Terminal Battery
92	532 19 66-15	Harness Pigtail Consle ROS
93	532 19 25-40	Screw Plastite 10-14 x 2.0
94	532 19 18-34	Module Reverse ROS

NOTE: All component dimensions given in U. S.
inches 1 inch = 25.4 mm.

TRACTOR - - MODEL NO. M13597 (96011023502), PRODUCT NO. 960 11 02-35
CHASSIS AND ENCLOSURES **39**

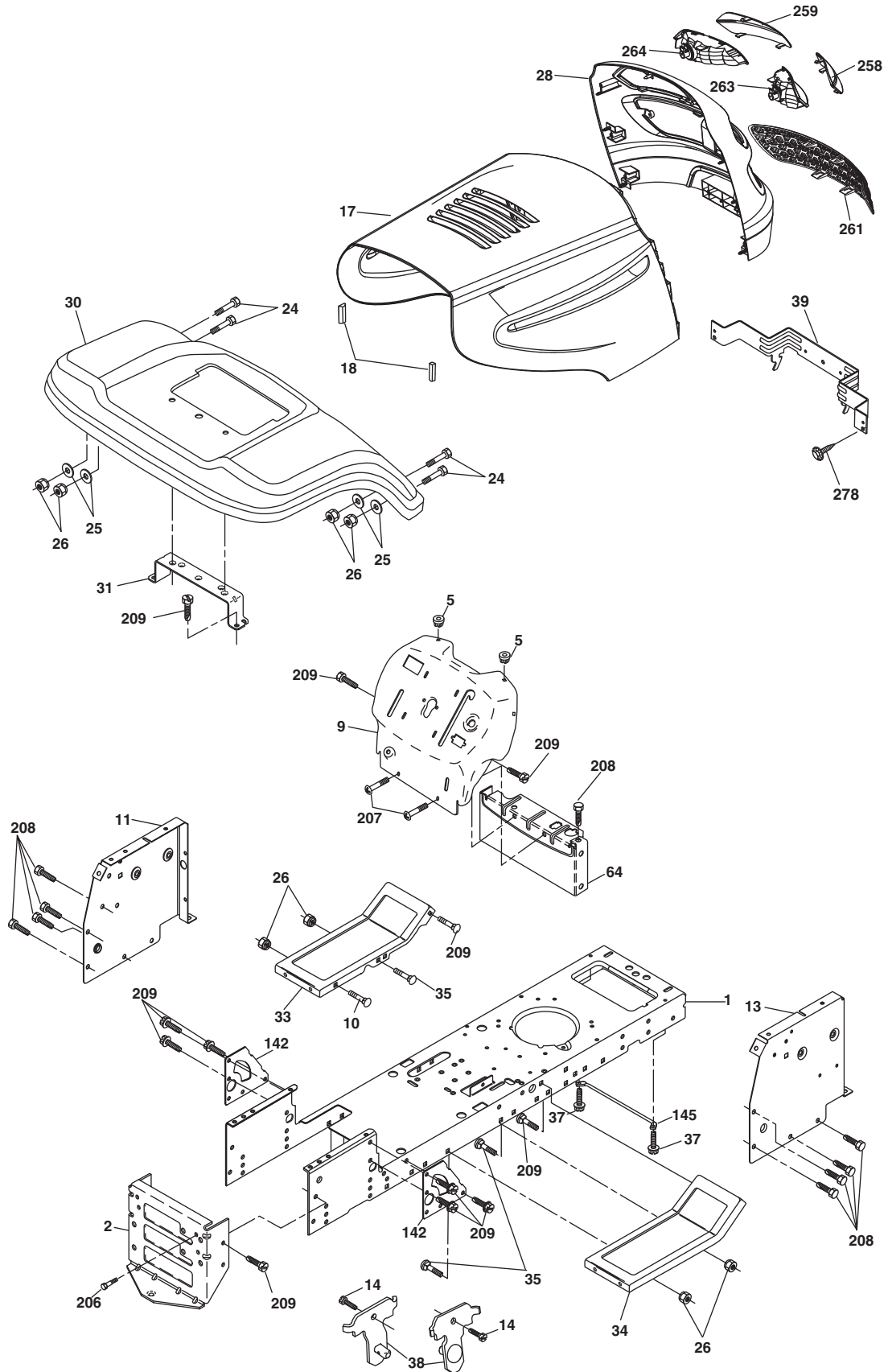

chassis_elite sv_pro_15

**TRACTOR - - MODEL NO. M13597 (96011023502), PRODUCT NO. 960 11 02-35
CHASSIS AND ENCLOSURES 39**

KEY NO.	PART NO.	DESCRIPTION
1	532 17 46-19	Chassis
2	532 17 65-54	Drawbar
5	532 15 52-72	Bumper, Hood/Dash
9	532 19 48-22	Dash
10	872 14 06-08	Bolt 3/8-16 x 1
11	532 17 49-96	Panel Dash LH
13	532 18 69-52	Panel Silkscr Dash RH
14	817 49 06-08	Screw 3/8-16 x 1/2
17	532 18 65-80	Hood
18	532 18 49-21	Bumper Hood
24	874 78 06-16	Bolt Fin Hex 3/8-16 unc x 1 Gr. 5
25	819 13 13-12	Washer 13/32 x 13/16 x 12 Ga.
26	873 80 06-00	Nut Lock Hex w/Ins 3/8-16 unc
28	532 18 82-24	Grille Asm. (Inc. 258, 259, 261, 263, 264)
30	532 19 41-98	Fender
31	532 13 66-19	Bracket Fender Repl 109873x
33	532 18 25-07	Footrest Pnt LH
34	532 18 25-08	Footrest Pnt RH
35	872 11 06-06	Bolt Rdhd Sht Sqnk 3/8-16 x 3/4
37	817 49 05-08	Screw Thdrol 5/16-18 x 1/2 TYT
38	532 17 57-10	Bracket Asm. Pivot Mower Rear
39	532 40 78-07	Bracket Pivot
64	532 15 47-98	Dash Lower
142	532 17 57-02	Plate Reinforcement
145	532 40 91-67	Rod Pivot Chassis/Hood
206	532 17 01-65	Bolt Shoulder 5/16-18
207	817 06 05-08	Screw 5/16-18 x 1/2
208	817 67 06-08	Screw Thdrol 3/8-16 x 1/2
209	817 00 06-12	Screw Hex Wsh Thdrol 3/8-16
258	532 18 97-55	Lens Grille RH
259	532 18 97-54	Lens, Grille LH
261	532 18 97-53	Insert Grille
263	532 18 38-33	Bezel Grille RH
264	532 18 38-32	Bezel Grille LH
278	532 19 16-11	Screw 10 x 3/4 Single Lead-Hex
- -	532 00 54-79	Plug Button Blk 359 Dia Choke

NOTE: All component dimensions given in U.S. inches
1 inch = 25.4 mm.

TRACTOR - - MODEL NO. M13597 (96011023502), PRODUCT NO. 960 11 02-35
DRIVE **40**

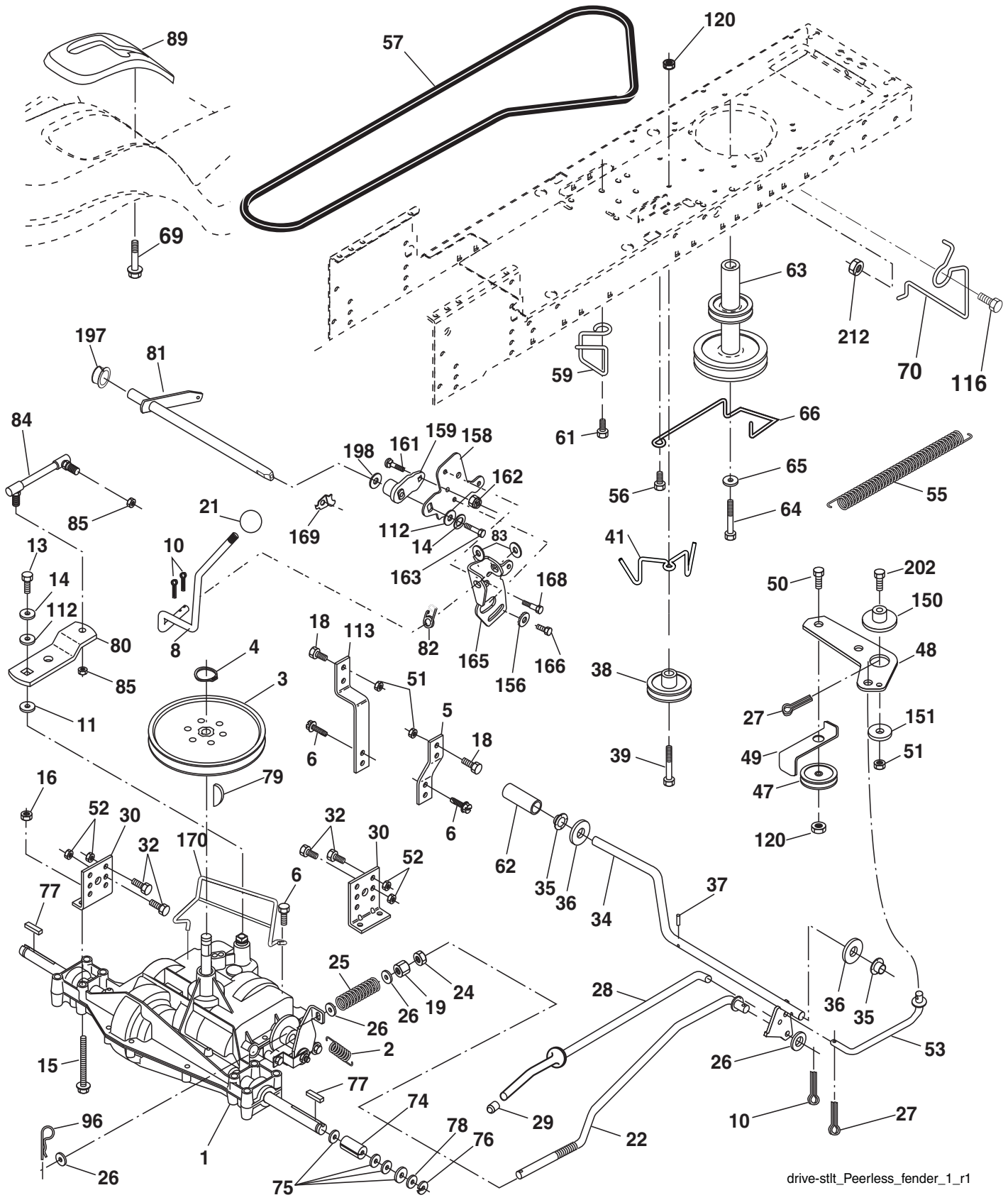

drive-sttt_Peerless_fender_1_r1

**TRACTOR - - MODEL NO. M13597 (96011023502), PRODUCT NO. 960 11 02-35
DRIVE 40**

KEY NO.	PART NO.	DESCRIPTION	KEY NO.	PART NO.	DESCRIPTION
1	-----	Transaxle, D6800	65	810 04 07-00	Washer Lock Hvy Hlcl Spr 7/16
2	532 14 66-82	Spring Return Brake T/a Zinc	66	532 15 47-78	Keeper Belt Engine Foolproof
3	532 12 36-66	Pulley Transaxle 18" tires	69	532 14 24-32	Screw Hex Wsh Hi-Lo 1/4 x 1/2 unc
4	812 00 00-28	Ring Retainer # 5100-62	70	532 13 46-83	Guide Belt Mower Drive RH
5	532 12 15-20	Strap Torque 30 Degrees	75	532 12 17-49	Washer 25/32 x 1 1/4 x 16 Ga
6	817 06 05-12	Screw 5/16-18 x 3/4	76	812 00 00-01	E-ring #5133-75
8	532 19 27-06	Rod Shifter	77	532 12 35-83	Key Square 2 0 x 1845/ 1865
10	876 02 04-16	Pin Cotter 1/8 x 1 Cad	78	532 12 17-48	Washer 25/32 x 1-5/8 x 16 Ga
11	532 10 57-01	Washer Plate Shf 388 Sq Hole	79	532 12 50-96	Key Woodruff
13	874 55 04-12	Bolt 1/4-28 Unf Gr 8 W/Patch	80	532 13 14-88	Arm Shift Transaxle
14	810 04 04-00	Washer Lock Hvy Helical 1/4	81	532 16 55-94	Shaft Asm. Cross Taper
15	874 49 05-44	Bolt Hex Flghd 5/16-18 Gr. 5	82	532 16 57-11	Spring Torsion Shift
16	873 80 05-00	Nut Lock Hx W/Ins 5/16-18 unc	83	819 17 12-16	Washer 17/32 x 3/4 x 16 Ga.
18	874 78 06-16	Bolt, Fin Hex 3/8-16 unc x 1 Gr. 5	84	532 16 62-29	Link Transaxle
19	873 80 06-00	Nut Lock 3/8-16 Unc	85	532 15 03-60	Nut Lock Center 1/4-28
21	532 10 69-33	Knob	89	532 19 49-71	Console SVC Shift
22	532 13 08-04	Rod Brake	96	532 12 47-88	Retainer Spring 1"
24	873 35 06-00	Nut Hex Jam 3/8-16 unc	112	819 09 12-10	Washer 9/32 x 3/4 x 10 Ga.
25	532 10 68-88	Spring Rod Brake 2 00 Zinc	113	532 12 72-85	Strap Torque Lh
26	819 13 13-16	Washer 13/32 x 13/16 x 16 Ga.	116	872 14 06-08	Bolt Rdhd Sq Neck 3/8-16 x 1.00
27	876 02 04-12	Pin Cotter 1/8 x 3/4 Cad	120	873 90 06-00	Nut Lock Flg 3/8-16
28	532 17 57-65	Rod Brake Parking	150	532 17 54-56	Spacer Retainer
29	532 07 16-73	Cap Brake Parking	151	819 13 32-10	Washer 13/32 x 2 x 10
30	532 17 49-73	Bracket Mtg Transaxle	156	532 16 60-02	Washer Srrtd 5/16ID x 1.0 x .125TK
32	874 76 05-12	Bolt Hex Hd 5/16-18unc x 3/4	158	532 16 55-89	Bracket Shift Mount
34	532 17 55-78	Shaft Asm Pedal Foot	159	532 18 39-00	Hub Shift
35	532 12 01-83	Bearing Nylon Blk 629 Id	161	872 14 04-06	Bolt RDHD SQNK 1/4-20 x 3/4 Gr.5
36	819 21 16-16	Washer 21/32 x 1 x 16 Ga.	162	873 68 04-00	Nut Crownlock 1/4-20 unc
37	532 12 49-63	Pin Roll 3/16 x 1"	163	874 78 04-16	Bolt Hex Fin 1/4-20 unc x 1 Gr. 5
38	532 17 91-14	Pulley Idler Composite	165	532 16 56-23	Bracket Pivot Lever
39	872 11 06-22	Bolt Rdhd 3/8-16 unc x 2-3/4 Gr. 5	166	817 49 05-10	Screw 5/16-18 x 5/8 TT Yellow
41	532 17 55-56	Keeper Belt Retainer Idler	168	532 16 54-92	Shoulder Bolt 5/16 -18 x .561
47	532 12 77-83	Pulley Idler V Groove Plastic	169	532 16 55-80	Plate Fastening
48	532 15 44-07	Bellcrank Asm	170	532 18 74-14	Keeper Belt T/A
49	532 12 32-05	Retainer Belt Style Spring	197	532 16 96-13	Nyliner Snap-in 5/8" ID
50	872 11 06-12	Bolt Carr Sh 3/8-16 x 1-1/2 Gr. 5	198	532 16 95-93	Washer Nyl
51	873 68 06-00	Nut Crownlock 3/8-16 unc	202	872 11 06-14	Bolt, 3/8 - 16 x 1-3/4 Gr. 5
52	873 68 05-00	Nut Crownlock 5/16-18 unc	212	532 14 52-12	Nut Flange Hex Lock
53	532 19 96-52	Link Clutch	263	817 00 06-12	Screw 3/8-16 x 3/4
55	532 10 57-09	Spring Return Clutch 6 75	268	532 18 24-02	Guard Muffler
56	817 06 06-20	Screw 3/8-16 x 1-1/4	275	819 13 16-14	Washer 13/32 x 1 x 14 Ga.
57	532 40 16-03	V-Belt Ground Drive			
59	532 16 96-91	Keeper Belt Span Ctr			
61	817 12 06-14	Screw 3/8-16 x .875			
62	532 12 48-72	Cover Pedal Blk Round			
63	532 17 54-10	Engine Pulley			
64	532 17 39-37	Bolt Hex			

NOTE: All component dimensions given in U.S. inches
1 inch = 25.4 mm

**TRACTOR - - MODEL NO. M13597 (96011023502), PRODUCT NO. 960 11 02-35
STEERING ASSEMBLY **41****

KEY NO.	PART NO.	DESCRIPTION
1	532 19 45-95	Wheel Steering
2	532 19 56-73	Axle Asm
3	532 16 98-40	Spindle Asm LH
4	532 16 98-39	Spindle Asm RH
5	532 12 49-31	Bearing Race Thrust Harden
6	532 12 17-48	Washer 25/32 x 1-5/8 x 16 Ga.
7	819 27 20-16	Washer 27/32 x 1-1/4 x 16 Ga.
8	812 00 00-29	Ring Klip #t5304-75
9	532 12 49-37	Bearing Col Strg Blk
10	532 17 51-21	Link Drag
11	810 04 06-00	Washer Lock Hvy Hlcl Spr 3/8
13	532 13 65-18	Spacer earing Axle Front
15	532 14 52-12	Hexflange Lock
17	532 19 07-53	Shaft Asm Strg
26	532 12 68-47	Bushing Link Drag Blk LR
28	819 13 14-16	Washer 13/32 x 7/8 x 16 Ga.
29	817 00 06-12	Screw 3/8-16 x 3/4
30	876 02 04-12	Pin Cotter 1/8 x 3/4 Cad
32	532 19 27-57	Rod Tie Wire Form 19 75 Mech
34	810 04 05-00	Washer Lock 5/16
36	532 15 50-99	Bushing Strg 5/8 Id Dash
37	532 15 29-27	Screw
38	532 19 46-03	Cap Wheel Steer
39	819 11 38-12	Washer 11/32 ID x 2 3/8 OD x 12 Ga.
40	873 54 06-00	Nut Crownlock 3/8-24
41	532 18 67-37	Adaptor Wheel Strg
42	532 16 96-33	Boot Steering
43	532 12 17-49	Washer 25/32 x 1 1/4 x 16 Ga.
44	532 19 07-52	Extension Steering
46	532 12 12-32	Cap Spindle Fr Top Blk
65	532 16 03-67	Spacer Brace Axle
67	872 11 06-18	Bolt RdHd Sqnk 3/8-16 x 2-1/4
68	532 16 98-27	Brace Axle
71	532 17 51-46	Steering Asm
82	532 19 99-78	Bracket Susp Chassis Front
88	532 17 51-18	Bolt shoulder 7/16-20
91	532 17 55-53	Clip Steering
95	532 18 89-67	Washer Hardened
97	874 78 05-64	Bolt 5/16-18 UNC x 4" L Gr. 5

NOTE: All component dimensions given in U.S. inches
1 inch = 25.4 mm.

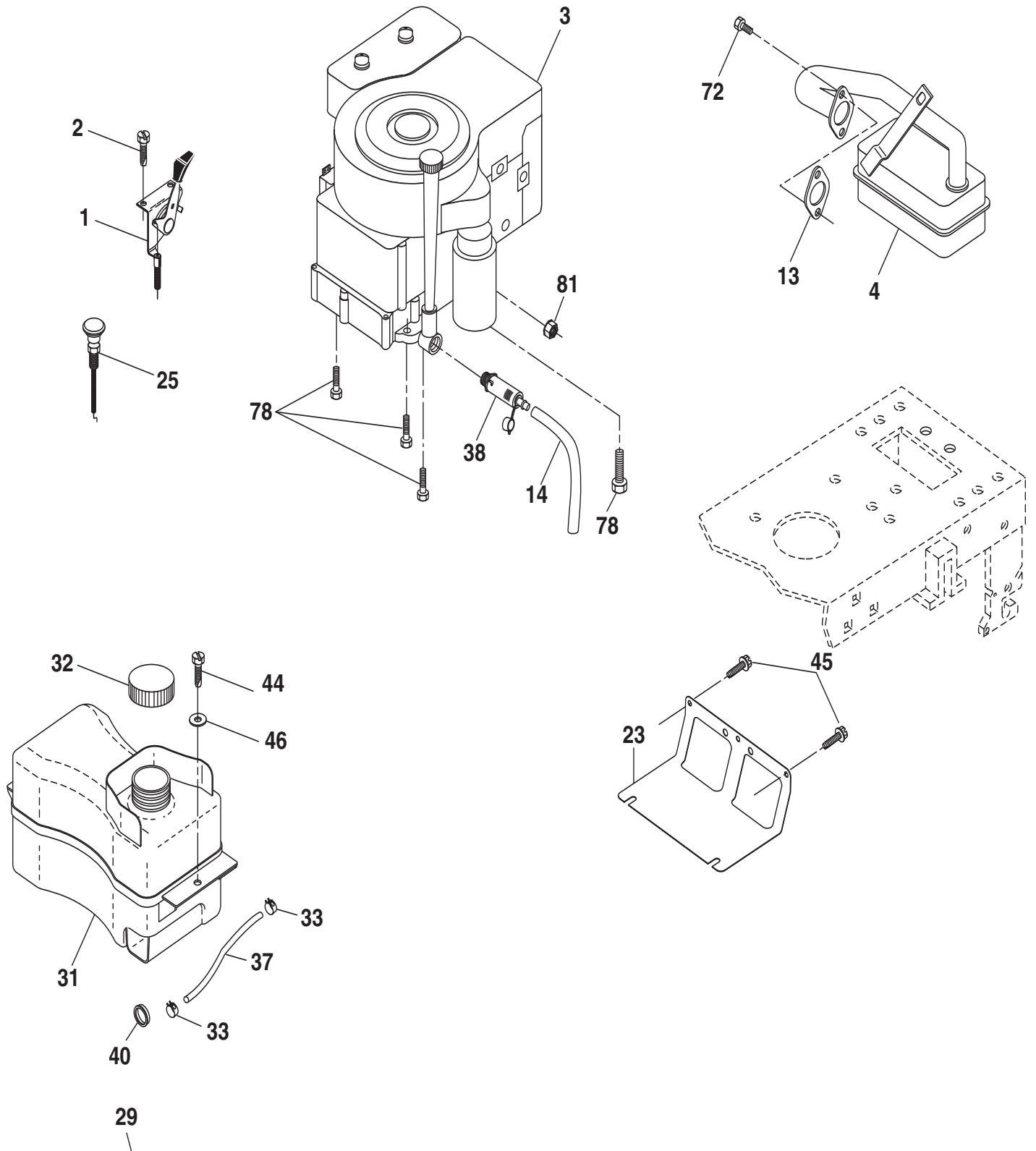

OPTIONAL EQUIPMENT
Spark Arrester

**TRACTOR - - MODEL NO. M13597 (96011023502), PRODUCT NO. 960 11 02-35
ENGINE 24**

KEY NO.	PART NO.	DESCRIPTION
1	532 17 05-51	Control Throttle /Choke
2	817 72 04-08	Screw Hex Thd Cut 1/4-20 x 5/8 T
3	-----	Engine Briggs Model 21B807
4	532 17 97-58	Muffler Exhaust
13	532 16 52-91	Gasket
14	532 14 84-56	Tube Drain Oil Easy
23	532 16 98-37	Shield Browning/Debris Guard
25	532 19 06-95	Choke Control
29	532 13 71-80	Arrestor Spark
31	532 40 75-16	Tank Fuel
32	532 19 77-25	Cap Asm Fule Top
33	532 12 34-87	Clamp Hose Blk
37	532 13 70-40	Line Fuel 20"
38	532 18 16-54	Plug Drain Oil Easy
40	532 12 40-28	Bushing Snap
44	817 67 04-12	Screw Hexwsh Thdrol 3/8-16 x 3/4
45	817 00 06-12	Screw 3/8-16 x 3/4
46	819 09 14-16	Washer 9/32 x 7/8 x 16 Ga.
72	532 19 23-34	Screw
78	817 06 06-20	Screw 3/8-16 x 1-1/4
81	873 51 04-00	Nut Keps Hex 1/4-20 unc

NOTE: All component dimensions given in U.S. inches
1 inch = 25.4 mm

Engine Power Rating Information

The gross power rating for individual gas engine models is labeled in accordance with SAE (Society of Automotive Engineers) code J11940 (Small Engine Power & Torque Rating Procedure), and rating performance has been obtained and corrected in accordance with SAE J1995 (Revision 2002-5). Actual gross engine power will be lower and is affected by, among other things, ambient operating conditions and engine-to-engine variability. Given both the wide array of products on which engines are placed and the variety of environmental issues applicable to operating the equipment, the gas engine will not develop the rated gross power when used in a given piece of power equipment (actual "on-site" or net horsepower). This difference is due to a variety of factors including, but not limited to, accessories (air cleaner, exhaust, charging, cooling, carburetor, fuel pump, etc.), application limitations, ambient operating conditions (temperature, humidity, altitude), and engine-to-engine variability. Due to manufacturing and capacity limitations, Briggs & Stratton may substitute an engine of higher rated power for this Series engine.

TRACTOR - - MODEL NO. M13597 (96011023502), PRODUCT NO. 960 11 02-35
SEAT ASSEMBLY 42

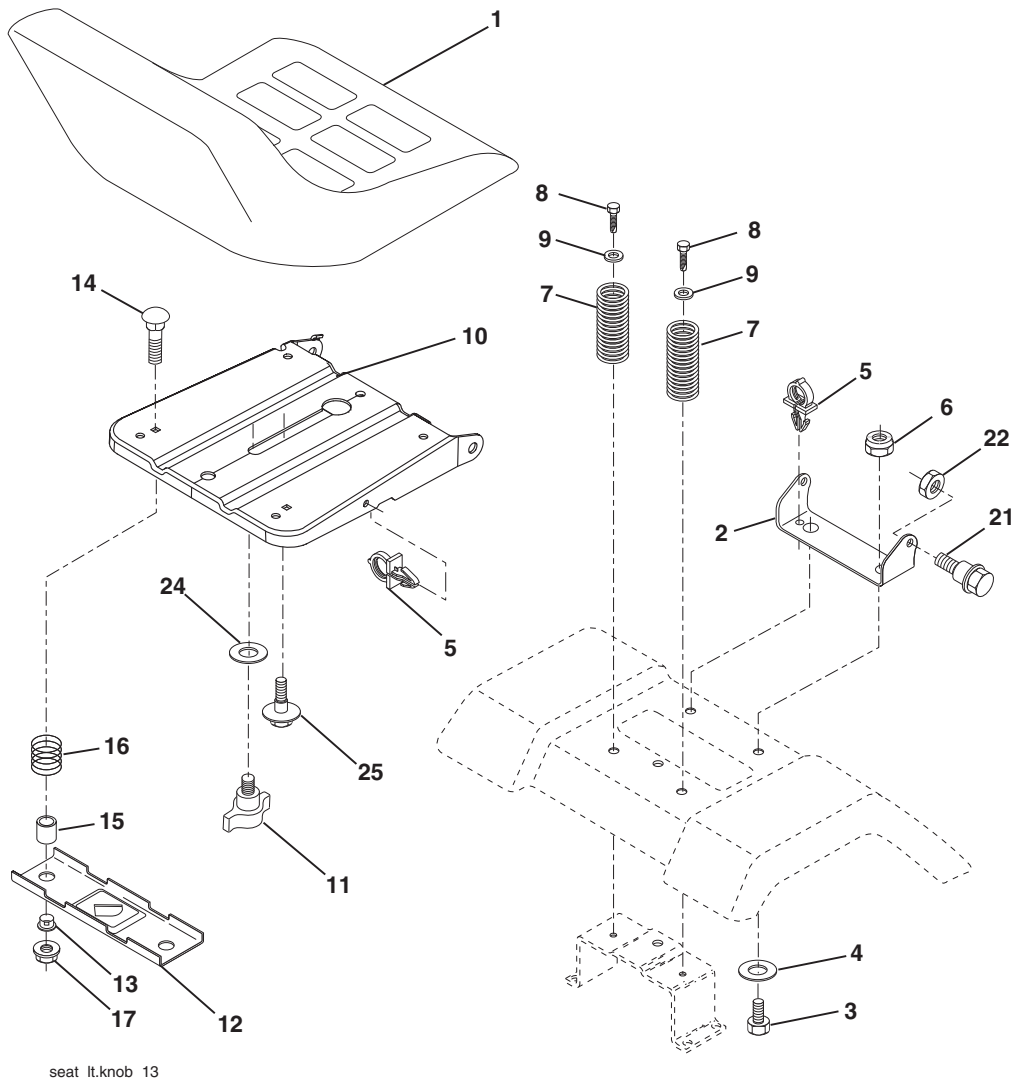

seat_lt.knob_13

KEY NO.	PART NO.	DESCRIPTION
1	532 18 87-13	Seat
2	532 14 05-51	Bracket Seat Pivot
3	871 11 06-16	Bolt Hex 3/8 - 16 x 1
4	819 13 16-10	Washer 13/32 x 1 x 10 Ga.
5	532 14 50-06	Clip Push-In Hinged
6	873 80 06-00	Nut Lock Hex w/Ins 3/8 - 16
7	532 12 41-81	Spring Seat Cprsn 2 250 Blk Zi
8	817 00 06-16	Screw 3/8-16 x 1.5
9	819 13 16-14	Washer 13/32 x 1 x 14 Ga.
10	532 19 55-30	Pan Pnt Seat (Blk)
11	532 16 63-69	Knob Seat
12	532 17 46-48	Bracket Pnt Mounting Switch

KEY NO.	PART NO.	DESCRIPTION
13	532 12 12-48	Bushing Snap Blk Nyl
14	872 05 04-12	Bolt Rdhd Sht Nk 1/4 - 20 x 1 -1/2
15	532 13 43-00	Spacer Split .28 x .96
16	532 12 12-50	Spring Cprsn
17	532 12 39-76	Nut Lock 1/4 Lge Flg
21	532 17 18-52	Bolt Shoulder 5/16-18 unc-2A
22	873 80 05-00	Nut Lock Hex w/Ins 5/16 - 18
24	819 17 19-12	Washer 17/32 x 1-3/16 x 12 Ga.
25	532 12 70-18	Bolt Shoulder 5/16-18 x .62

NOTE: All component dimensions given in U.S. inches
 1 inch = 25.4 mm.

**TRACTOR - - MODEL NO. M13597 (96011023502), PRODUCT NO. 960 11 02-35
MOWER LIFT 45**

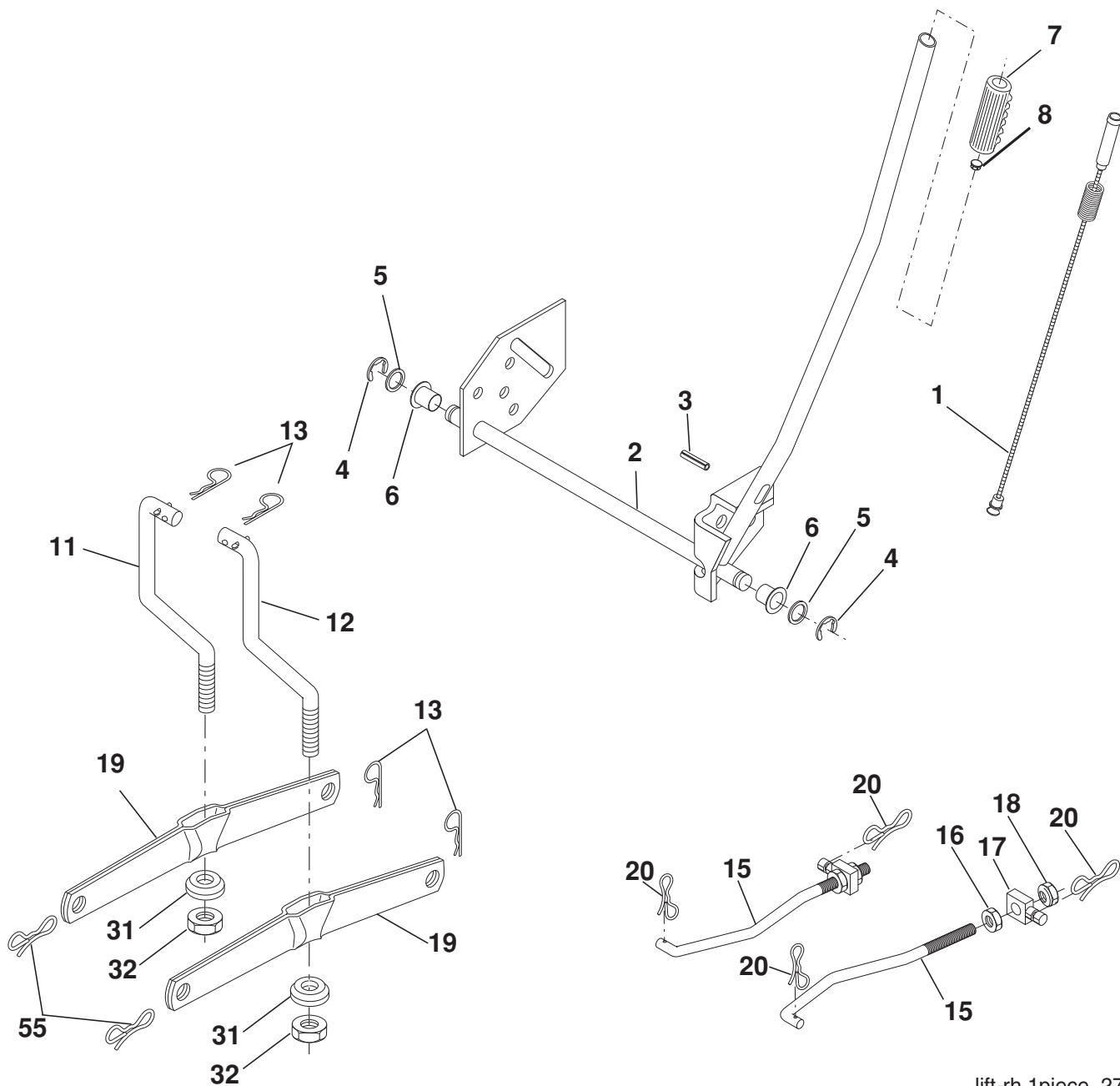

lift-rh.1piece_27

KEY NO.	PART NO.	DESCRIPTION
1	532 19 84-17	Wire Asm Inner/Sprg w/plunger
2	532 19 80-70	Shaft Asm Lift RH
3	532 18 88-22	Pin Groove
4	812 00 00-02	E Ring #5133-62
5	819 21 16-21	Washer 21/32 x 1 x 21 Ga
6	532 12 01-83	Bearing Nylon Blk 629 Id
7	532 10 94-13	Grip Handle Bicycle Matte Blk
8	532 12 45-26	Button Plunger Black
11	532 13 98-65	Link Lift LH Fixed Length
12	532 13 98-66	Link Lift RH Fixed Length
13	532 12 46-70	Retainer Spring

KEY NO.	PART NO.	DESCRIPTION
15	532 17 32-88	Link Front
16	873 35 08-00	Nut Jam Hex 1/2-13 Unc
17	532 17 56-89	Trunnion
18	873 80 08-00	Nut Lockw/Wsh 1/2-13 Unc
19	532 13 98-68	Arm Suspension Rear
20	532 19 42-09	Retainer, Spring
31	532 16 98-65	Bearing Pvt Lift
32	873 54 06-00	Nut Crownlock 3/8-24
55	532 12 42-08	Pin, Cotter 5/16 Bow Tie Lock

NOTE: All component dimensions given in U.S. inches
1 inch = 25.4 mm.

TRACTOR - - MODEL NO. M13597 (96011023502), PRODUCT NO. 960 11 02-35
MOWER DECK 44

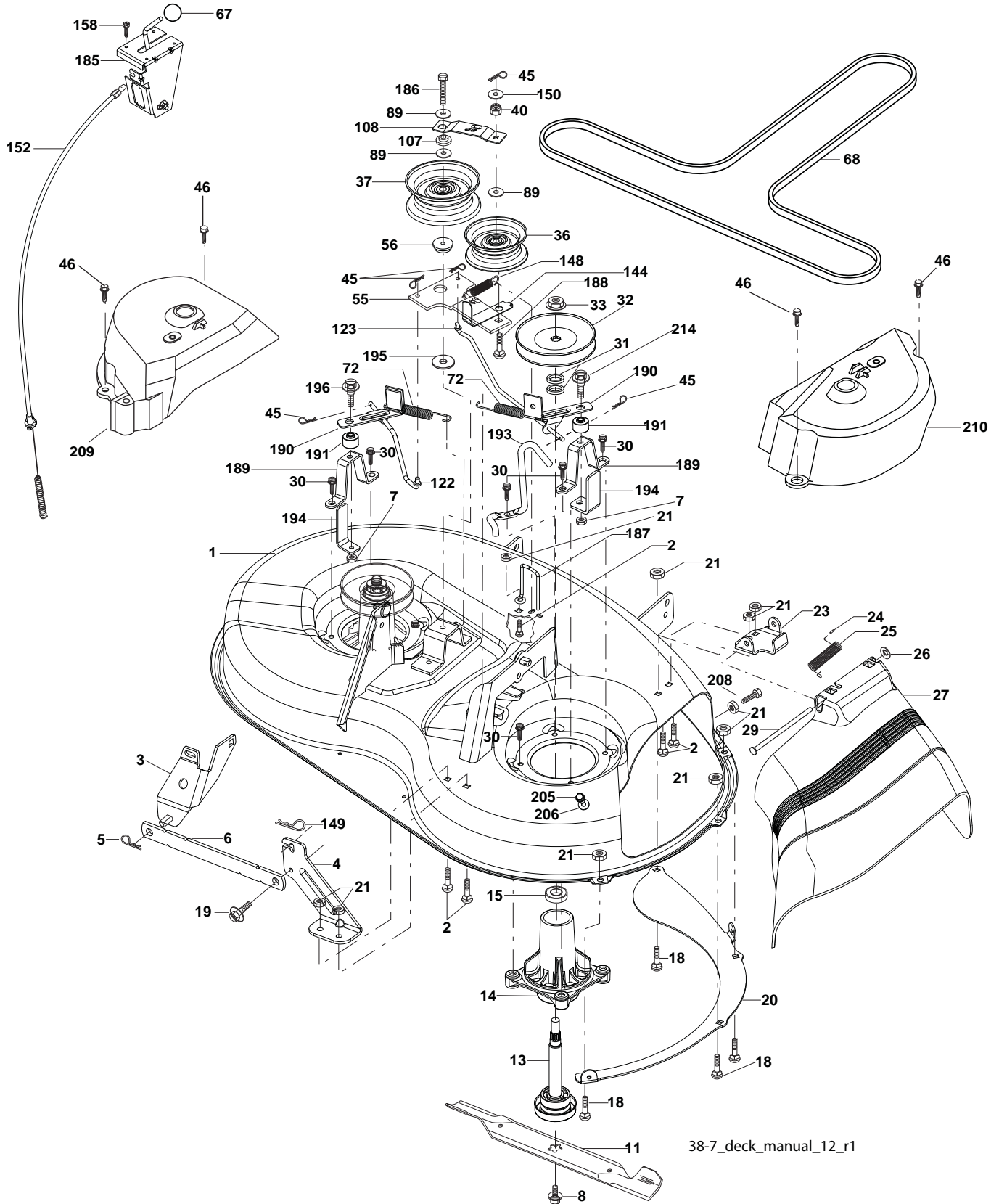

38-7_deck_manual_12_r1

**TRACTOR - - MODEL NO. M13597 (96011023502), PRODUCT NO. 960 11 02-35
MOWER DECK **44****

KEY NO.	PART NO.	DESCRIPTION	KEY NO.	PART NO.	DESCRIPTION
1	532 19 25-56	Mower Housing Assembly	107	532 13 35-02	Spacer Retainer
2	872 14 05-06	Bolt Carriage 5/16-18 x 3/4	108	532 13 35-03	Stiffener, Idler Arm
3	532 13 80-17	Bracket Asm Fr. Sway Bar	122	532 41 01-89	Link. Brake LH
4	532 19 25-68	Bracket Deck Sway Bar 38"/42"	123	532 41 01-90	Link. Brake RH
5	532 12 46-70	Retainer Spring	144	532 19 34-14	Keeper Belt Idler Tension
6	532 17 80-24	Bar Sway Deck	148	532 16 90-22	Spring Return Idler
7	873 80 05-00	Nut Lock Hex w/Ins. 5/16-18 unc	149	532 16 58-98	Retainer Spring Yellow
8	532 19 30-03	Bolt 3/8-24 x 1.25 Gr. 8	150	819 09 12-10	Washer 9/32 x 3/4 x 10 Ga.
11	532 19 39-57	Blade Mower	152	532 19 32-35	Clutch Cable 38"/46"
13	532 19 28-72	Shaft Assembly, Mandrel, Vented	158	817 72 04-08	Screw Hex Thd Cut 1/4-20 x 1/2
14	532 18 72-81	Housing, Mandrel, Vented	185	532 18 82-34	Head Asm Cable Clutch
15	532 11 04-85	Bearing, Ball, Mandrel	186	817 49 06-44	Screw Hex Wsh Thdrol 3/8-16 x 2-3/4
18	872 14 05-05	Bolt Rdhd Sqnk 5/16-18 x 5/8	187	532 19 34-12	Keeper Belt
19	532 13 28-27	Bolt, Shoulder	188	532 16 58-91	Bolt Carriage Idler
20	532 40 00-95	Baffle Vortex Front	189	532 19 25-59	Stand, Brake
21	873 68 05-00	Nut	190	532 19 25-60	Arm, Brake
23	532 19 25-57	Bracket, Mower Deflector	191	532 19 25-61	Spacer, Brake
24	532 10 53-04	Cap, Sleeve	193	532 19 34-13	Keeper Belt Rh Mandrel
25	532 19 70-26	Spring, Torsion, Deflector	194	532 19 41-05	Guard Brake
26	532 11 04-52	Nut, Push	195	819 13 32-10	Washer
27	532 40 16-18	Shield, Deflector	205	817 49 04-16	Screw 1/4-20 x 1
29	532 13 14-91	Rod, Hinge	206	819 09 14-16	Washer 9/32 x 7/8 x 16 Ga.
30	532 17 39-84	Screw Thdrol.	208	817 67 06-08	Screw 3/8-16 x 1/2
31	532 18 76-90	Washer, Spacer	209	532 40 92-56	Cover Mandrel LH
32	532 15 35-32	Pulley, Mandrel	210	532 40 92-57	Cover Mandrel RH
33	532 40 02-34	Nut, Toplock	214	532 19 37-82	Bolt/Washer Asm 5/16-18
36	532 13 14-94	Pulley, Idler, Flat	--	532 19 25-58	Brake Assembly (Includes Stand, Arm and Guard Components)
37	532 19 31-98	Pulley Idler Flat	--	532 19 28-70	Mandrel Assembly (Includes Housing, Shaft and Shaft Hardware Only - Pulley Not Included)
40	873 68 06-00	Nut, Crownlock 3/8-16 unc	--	532 19 36-46	Replacement Mower, Complete
45	532 12 47-88	Retainer			
46	532 13 77-29	Screw 1/4-20 x 5/8			
55	532 13 38-40	Idler Arm Assembly			
56	532 16 57-23	Spacer, Retainer			
67	532 10 69-32	Knob			
68	532 19 32-14	V-Belt			
72	532 19 32-16	Spring Brake Return			
89	819 13 13-11	Washer 13/32 x 13/16 x 11 Ga.			
92	873 80 06-00	Nut Lock Hex W/Ins. 3/8-16 unc			

NOTE: All component dimensions given in U.S. inches
1 inch = 25.4 mm

