

**REPAIR PARTS MANUAL**  
**MODEL NO. 14596 (BA14596A)**  
**Lawn Tractor**

---

 **McCULLOCH**®

# HOW TO USE THIS MANUAL

This manual is designed to provide the customer with a means to identify the parts on his/her tractor when ordering repair parts. The illustrations may or may not represent the actual assemblies; therefore, it is not recommended to use this manual as a guide to assemble or disassemble the tractor. Some hardware and parts are drawn larger in order to more readily identify them.

Each tractor has its own model number.

The model number for your tractor can be found on the fender under the seat.

When ordering parts, always give the following information:

- Product - "Lawn Tractor"
- Model Number - 14596 (BA14596A)
- Part Number
- Part Description

## TABLE OF CONTENTS

<b>SCHEMATIC .....</b>	<b>3</b>
<b>ELECTRICAL.....</b>	<b>4-5</b>
<b>CHASSIS AND ENCLOSURES.....</b>	<b>6-7</b>
<b>DRIVE.....</b>	<b>8-9</b>
<b>STEERING .....</b>	<b>10-11</b>
<b>ENGINE.....</b>	<b>12-13</b>
<b>SEAT .....</b>	<b>14</b>
<b>DECALS.....</b>	<b>15</b>
<b>MOWER LIFT .....</b>	<b>16-17</b>
<b>MOWER DECK .....</b>	<b>18-19</b>

# TRACTOR - - MODEL NUMBER 14596 (BA14596A), PRODUCT NO. 964 77 96-00 SCHEMATIC

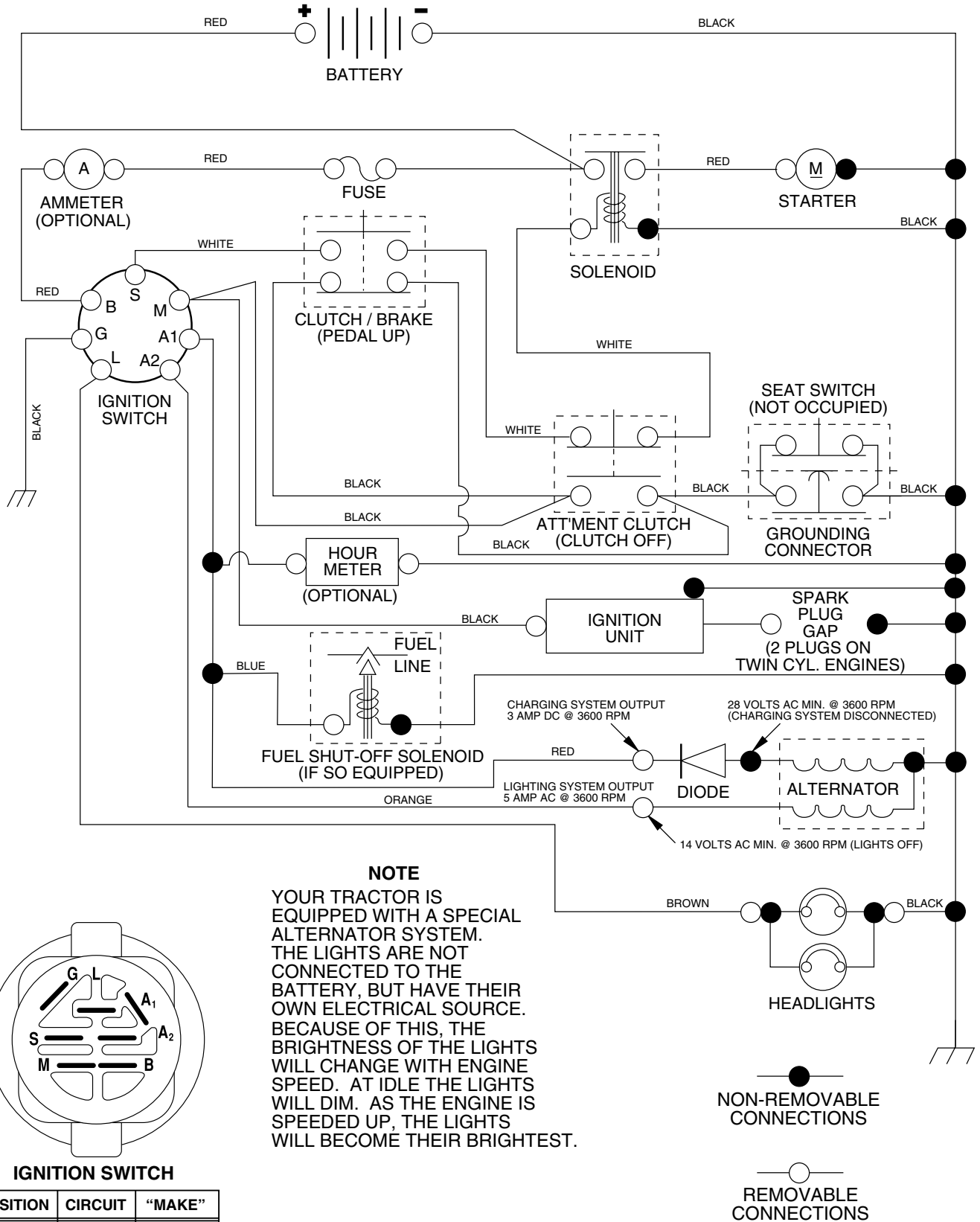

# REPAIR PARTS

TRACTOR - - MODEL NUMBER 14596 (BA14596A), PRODUCT NO. 964 77 96-00  
ELECTRICAL

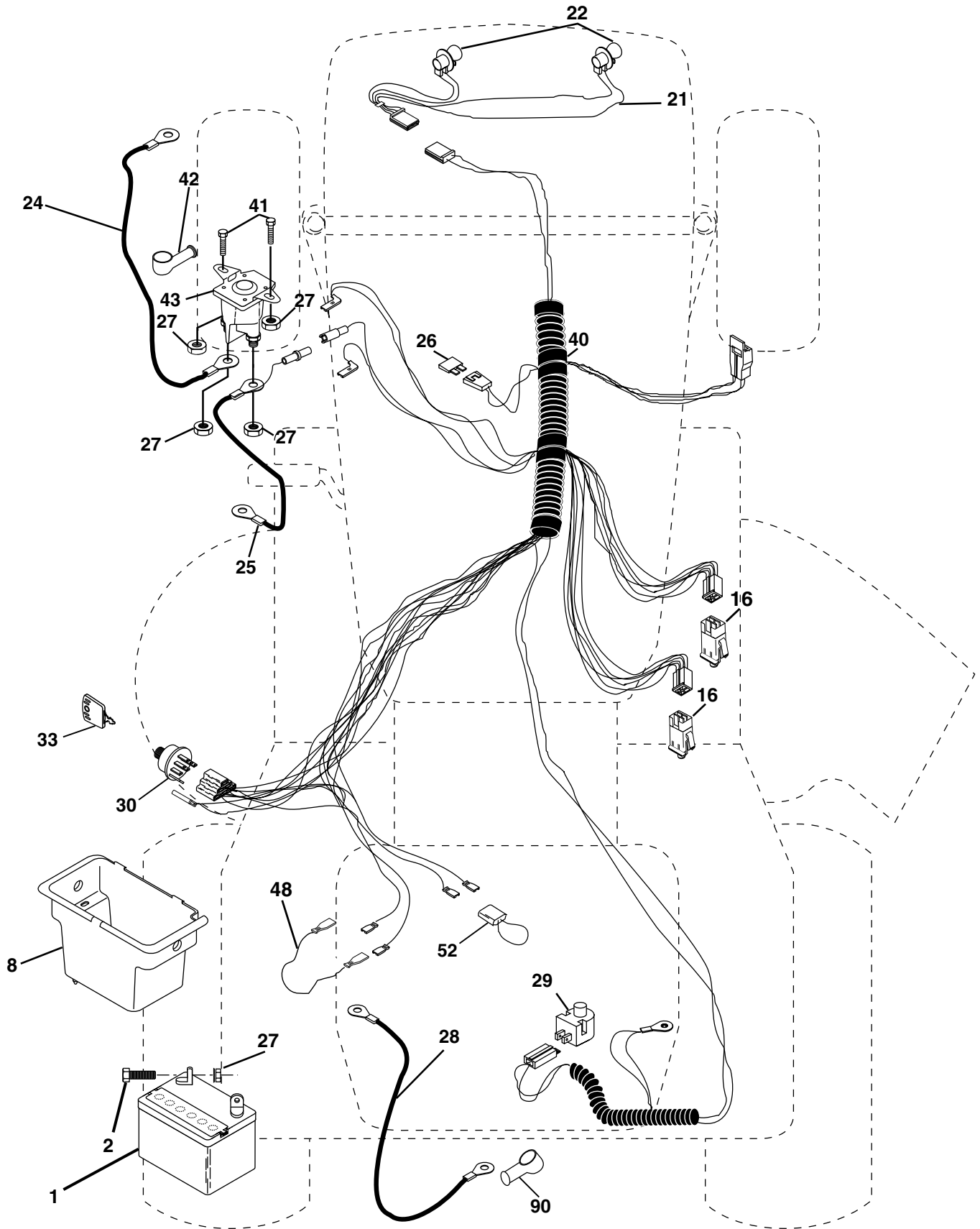

# REPAIR PARTS

TRACTOR - - MODEL NUMBER 14596 (BA14596A), PRODUCT NO. 964 77 96-00  
ELECTRICAL

KEY NO.	PART NO.	DESCRIPTION
1	532 16 34-65	Battery 12 Volt 25 Amp
2	874 76 04-12	Bolt Hex Hd 1/4-20unc X 3/4
8	532 17 66-89	Case Battery Mech Hinge
16	532 17 61-38	Switch Interlock Push-In
21	532 17 56-85	Harness Light
22	532 00 41-52	Bulb
24	532 12 47-80	Cable Battery
25	532 14 61-47	Cable Battery
26	532 17 51-58	Fuse
27	873 51 04-00	Nut Keps Hex 1/4-20 Unc
28	532 12 47-73	Cable Ground 6 Ga 12"black
29	532 12 13-05	Switch Plunger Nc Gray
30	532 17 55-66	Switch Ign
33	532 14 04-01	Key Ign
40	532 17 97-20	Harness Ign
41	871 11 04-08	Bolt Blk Fin Hex 1/4-20
42	532 13 15-63	Cover Terminal Red
43	532 17 88-61	Solenoid
48	532 14 08-44	Adapter Ammeter
52	532 14 19-40	Protection Wire Loop
90	532 18 04-49	Cover Terminal Battery

**NOTE:** All component dimensions given in U. S.  
inches 1 inch = 25.4 mm.

# REPAIR PARTS

TRACTOR - - MODEL NUMBER 14596 (BA14596A), PRODUCT NO. 964 77 96-00  
CHASSIS

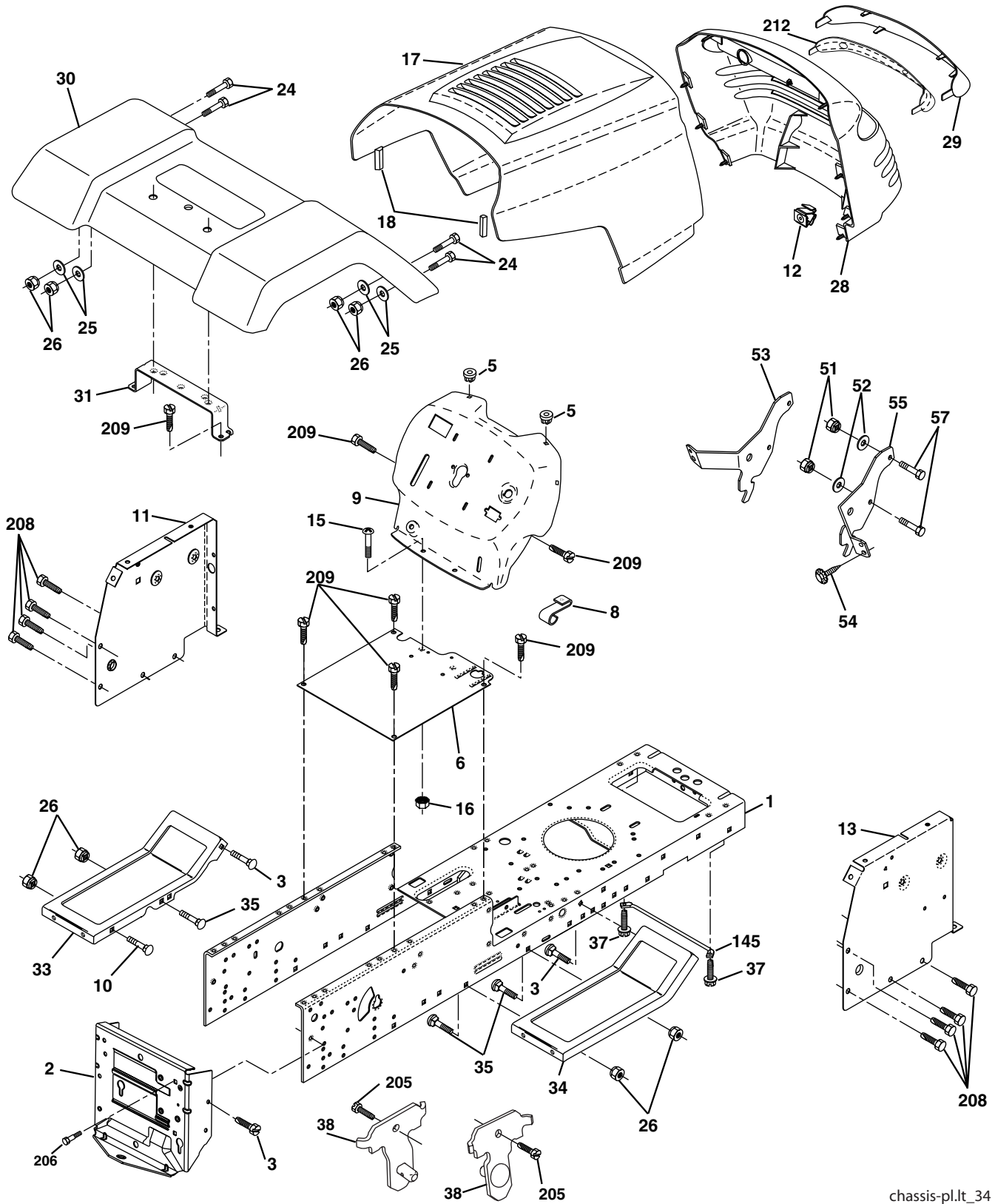

chassis-pl.lt\_34

# REPAIR PARTS

## TRACTOR - - MODEL NUMBER 14596 (BA14596A), PRODUCT NO. 964 77 96-00 CHASSIS

KEY NO.	PART NO.	DESCRIPTION
1	532 17 46-20	Chassis
2	532 17 65-54	Drawbar
3	817 06 06-12	Screw 3/8-16 x 3/4
5	532 15 52-72	Bumper, Hood/Dash
6	532 18 57-40	Saddle
8	532 15 51-38	Clip Retainer Slide-On
9	532 18 54-80	Dash
10	872 14 06-08	Bolt, Carriage 3/8-16 x 1
11	532 17 49-96	Panel Dash LH
12	532 14 56-60	Clip Tinnerman Grille P.L
13	532 18 17-19	Panel Silkscr Dash RH
15	874 18 05-12	Screw Mach TRHD 5/16-18uncx3/4
16	873 51 05-00	Nut Keps 5/16-18 Unc
17	532 18 25-05	Hood
18	532 18 49-21	Bumper Hood
24	874 78 06-16	Bolt Fin Hex 3/8-16unc X 1 Gr. 5
25	819 13 13-12	Washer 13/32 X 13/16 X 12 Ga
26	873 80 06-00	Nut Lock Hex w/Ins 3/8-16 Unc
28	532 17 97-77	Grille/Lens Asm.
29	532 17 59-02	Lens Grille
30	532 18 57-41	Fender
31	532 13 66-19	Bracket Fender Repl 109873x
33	532 18 25-08	Footrest Pnt LH
34	532 18 25-07	Footrest Pnt RH
35	872 11 06-06	Bolt Rdhd Sht Sqnk 3/8-16 X3/4
37	817 49 05-08	Screw Thdrol 5/16-18 x 1/2 TYT
38	532 17 57-10	Bracket Asm. Pivot Mower Rear
51	873 80 04-00	Nut Lock W/Insert 1/4-20unc
52	819 09 14-16	Washer 9/32 x 7/8x16 Ga.
53	532 14 46-97	Bracket Grille Lh
54	532 16 14-64	Screw Hex 8-18 x 7/8
55	532 14 46-96	Bracket Grille Rh
57	874 78 04-12	Bolt Fin Hex 1/4-20 unc x .75
145	532 15 65-24	Rod Pivot Chassis/Hood
205	817 49 06-08	Screw Thdrol 3/8-16 x 1/2
206	532 17 01-65	Bolt Shoulder 5/16-18
208	817 67 06-08	Screw Thdrol 3/8-16 x 1/2
209	817 00 06-12	Screw Hex Wsh Thdrol 3/8-16
212	532 15 64-94	Insert Lens Reflect
---	532 00 54-79	Plug Button Blk 359 Dia Choke

**NOTE:** All component dimensions given in U.S. inches  
1 inch = 25.4 mm.

# REPAIR PARTS

TRACTOR -- MODEL NUMBER 14596 (BA14596A), PRODUCT NO. 964 77 96-00  
DRIVE

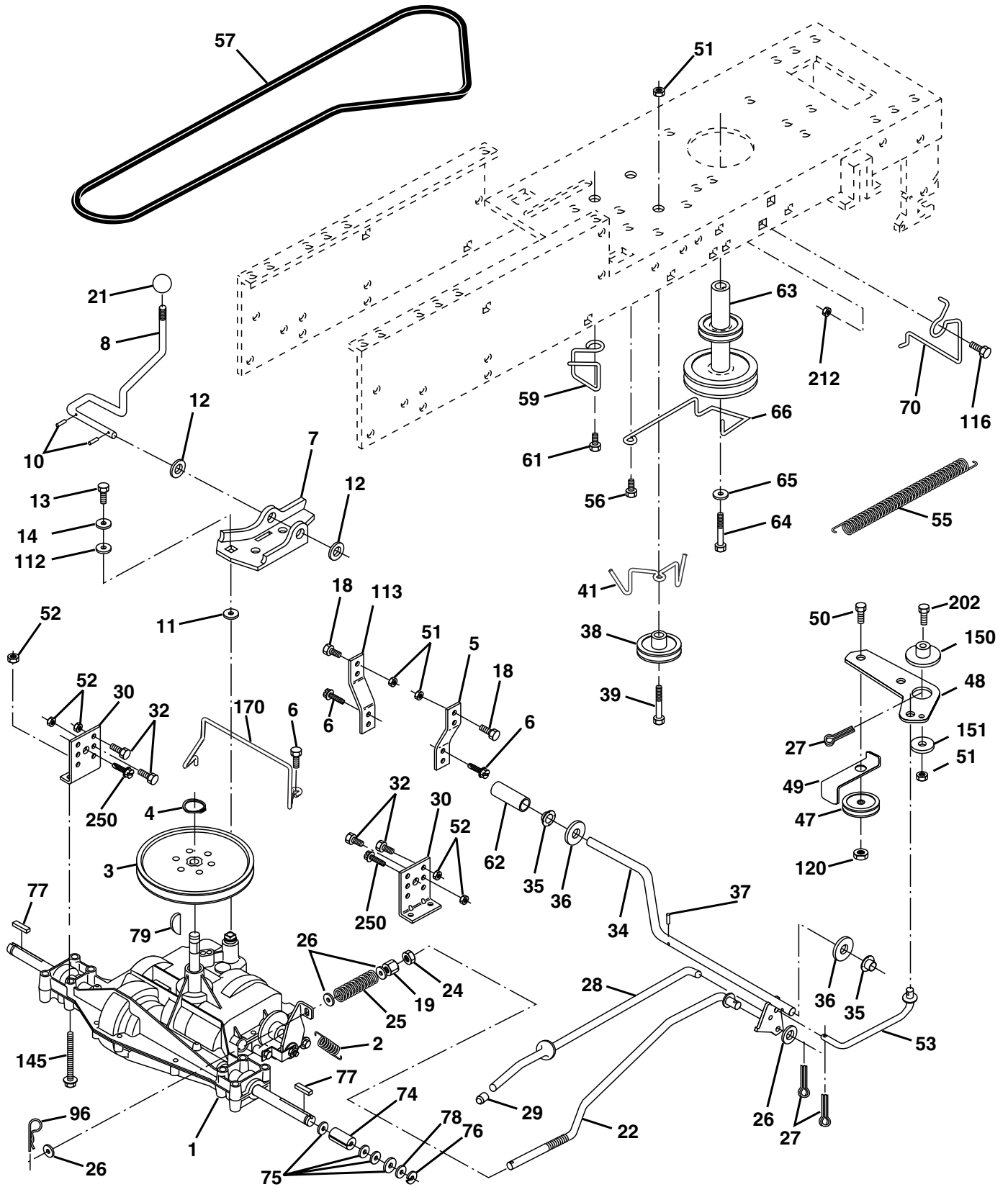



# REPAIR PARTS

## TRACTOR - - MODEL NUMBER 14596 (BA14596A), PRODUCT NO. 964 77 96-00 DRIVE

KEY NO.	PART NO.	DESCRIPTION	KEY NO.	PART NO.	DESCRIPTION
1	-----	Transaxle, Dana D4360-139 (Order parts from transaxle manufacturer)	51	873 68 06-00	Nut Crownlock 3/8-16 Unc
2	532 14 66-82	Spring Return Brake T/a Zinc	52	873 68 05-00	Nut Crownlock 5/16-18 Unc
3	532 12 36-66	Pulley Transaxle 18" tires	53	532 10 57-10	Link Clutch
4	812 00 00-28	Ring Retainer # 5100-62	55	532 10 57-09	Spring Return Clutch 6 75
5	532 12 15-20	Strap Torque 30 Degrees	56	817 06 06-20	Screw 3/8-16 X 1-1/4
6	817 00 05-12	Screw 5/16-18 x 3/4	57	532 16 08-55	V-Belt Ground Drive
7	532 16 22-40	Bracket T/A Saddle Shift	59	532 16 96-91	Keeper Belt Span Ctr
8	532 13 16-79	Rod Shifter	61	817 12 06-14	Screw 3/8-16 x .875
10	876 02 04-16	Pin Cotter 1/8 x 1 Cad	62	532 12 48-72	Cover Pedal Blk Round
11	532 10 57-01	Washer Plate Shf 388 Sq Hole	63	532 18 02-12	Engine Pulley
12	819 15 12-16	Washer 15/32 x 3/4 x 16	64	871 17 07-64	Bolt Hex
13	874 55 04-12	Bolt 1/4-28 Unf Gr 8 W/Patch	65	810 04 07-00	Washer Lock Hvy Hlcl Spr 7/16
14	810 04 04-00	Washer Lock Hvy Helical 1/4	66	532 15 47-78	Keeper Belt Engine Foolproof
18	874 78 06-16	Bolt, Fin Hex 3/8-16 UNC x 1 Gr. 5	70	532 18 02-18	Guide Belt Mower Drive RH
19	873 80 06-00	Nut Lock 3/8-16 Unc	74	532 10 95-02	Spacer Axle
21	532 10 69-33	Knob	75	532 12 17-49	Washer 25/32 X 1 1/4 X 16 Ga
22	532 13 08-04	Rod Brake Blk Zinc 26 840	76	812 00 00-01	E-ring #5133-75
24	873 35 06-00	Nut Hex Jam 3/8-16 Unc	77	532 12 35-83	Key Square 2 0 X 1845/ 1865
25	532 10 68-88	Spring Rod Brake 2 00 Zinc	78	532 12 17-48	Washer 25/32 X 1-5/8 X 16 Ga
26	819 13 13-16	Washer 13/32 X 13/16 X 16 Ga	79	532 12 50-96	Key Woodruff
27	876 02 04-12	Pin Cotter 1/8 X 3/4 Cad	80	532 12 47-88	Arm Shift
28	532 17 57-65	Rod Brake Parking	112	819 09 12-10	Washer 9/32 x 3/4 x 10 Ga.
29	532 07 16-73	Cap Brake Parking	113	532 12 72-85	Strap Torque Lh
30	532 17 49-73	Bracket Mtg Transaxle	116	872 14 06-08	Bolt Rdhd Sq Neck 3/8-16 x 1.00
34	532 17 55-78	Shaft Asm Pedal Foot	120	873 90 06-00	Nut Lock Flg 3/8-16
35	532 12 01-83	Bearing Nylon Blk 629 Id	145	874 49 05-40	Bolt Hex 5/16-18 Gr. 5
36	819 21 16-16	Washer 21/32 X 1 X 16 Ga	150	532 17 54-56	Spacer Retainer
37	532 12 49-63	Pin Roll 3/16 X 1"	151	819 13 32-10	Washer 13/32 x 2 x 10
38	532 17 91-14	Pulley Idler Composite	170	532 17 83-94	Keeper Belt T/A
39	874 76 06-48	Bolt Fin Hex 3/8-16unc X 3	202	872 11 06-14	Bolt, Carriage 3/8 - 16 x 1-3/4
41	532 17 55-56	Keeper Belt Retainer Idler	212	532 14 52-12	Nut Flange Hex Lock
47	532 12 77-83	Pulley Idler V Groove Plastic	250	817 06 06-12	Screw 3/8-16 x .75
48	532 15 44-07	Bellcrank Asm			
49	532 12 32-05	Retainer Belt Style Spring			
50	872 11 06-12	Bolt 3/8-16 X 1-1/2 Gr. 5			

**NOTE:** All component dimensions given in U.S. inches  
1 inch = 25.4 mm

# REPAIR PARTS

TRACTOR - - MODEL NUMBER 14596 (BA14596A), PRODUCT NO. 964 77 96-00  
STEERING

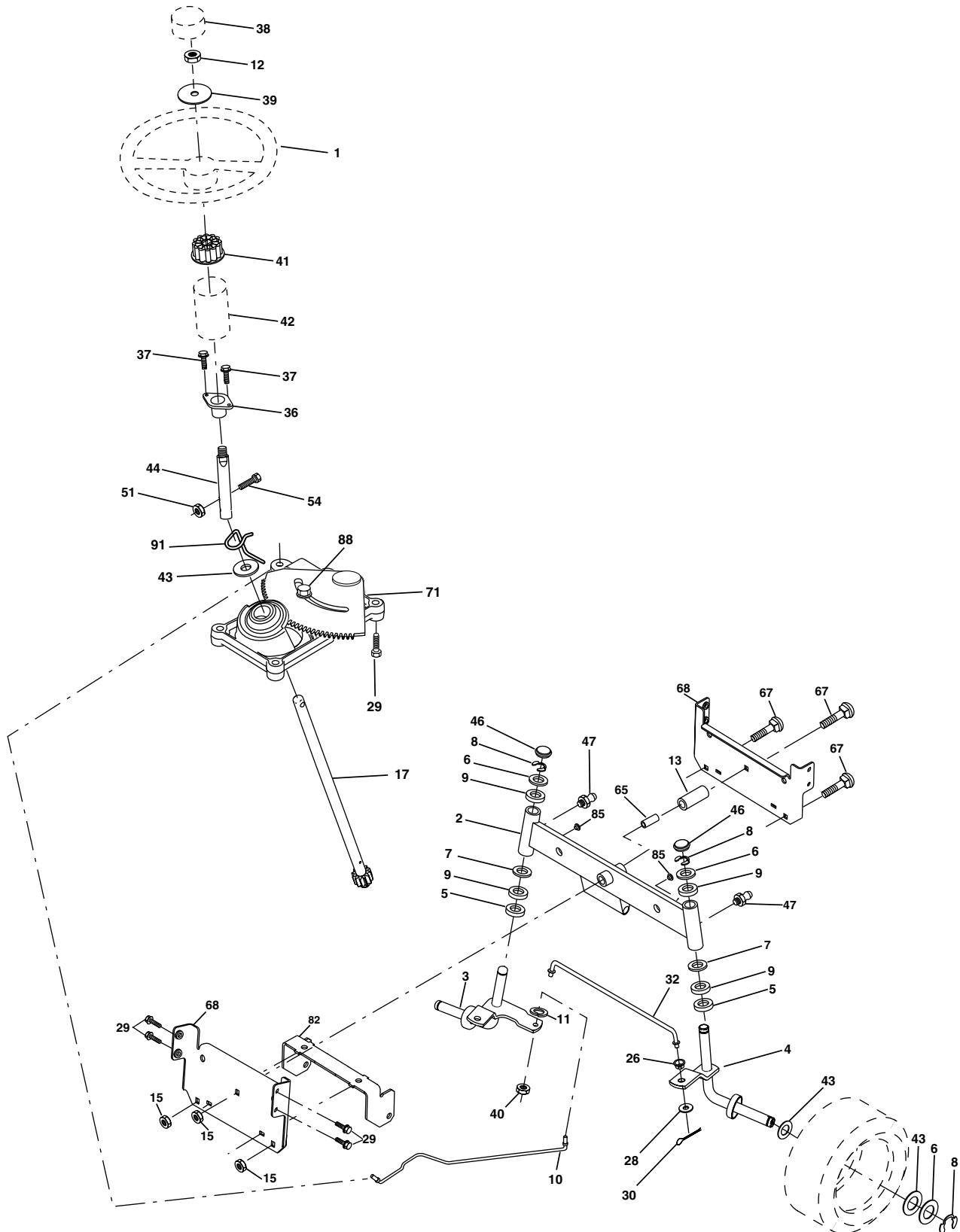

# REPAIR PARTS

## TRACTOR - - MODEL NUMBER 14596 (BA14596A), PRODUCT NO. 964 77 96-00 STEERING

KEY NO.	PART NO.	DESCRIPTION
1	532 17 59-04	Wheel Steering
2	532 17 51-31	Axle Asm
3	532 16 98-40	Spindle Asm LH
4	532 16 98-39	Spindle Asm RH
5	532 12 49-31	Bearing Race Thrust Harden
6	532 12 17-48	Washer 25/32 X 1-5/8 X 16 Ga
7	819 27 20-16	Washer 27/32 X 1-1/4 X 16 Ga
8	812 00 00-29	Ring Klip #t5304-75
9	532 12 49-37	Bearing Col Strg Blk
10	532 17 51-21	Link Drag
11	810 04 06-00	Washer Lock Hvy Hlcl Spr 3/8
12	873 94 08-00	Nut 1/2-20 Unf
13	532 13 65-18	Spacer earing Axle Front
15	532 14 52-12	Hexflange Lock
17	532 18 06-41	Shaft Asm Strg
26	532 12 68-47	Bushing Link Drag Blk LR
28	819 13 14-16	Washer 13/32 X 7/8 X 16 Ga
29	817 06 06-12	Screw 3/8-16 x 3/4
30	876 02 04-12	Pin Cotter 1/8 X 3/4 Cad
32	532 13 04-65	Rod Tie Wire Form 19 75 Mech
36	532 15 50-99	Bushing Strg 5/8 Id Dash
37	532 15 29-27	Screw
38	532 17 59-05	Cap Wheel Steer
39	819 18 38-12	Washer 9/16 ID x 2-3/8 OD 12 Ga.
40	532 12 47-01	Nut Lock Center 3/8-24un
41	532 10 07-11	Adaptor Wheel Strg
42	532 16 96-33	Boot Steering
43	532 12 17-49	Washer 25/32 X 1 1/4 X 16 Ga
44	532 18 06-40	Extension Steering
46	532 12 12-32	Cap Spindle Fr Top Blk
47	532 18 32-26	Fitting Grease
51	873 54 04-00	Nut Crownlock 1/4-28
54	871 13 04-20	Bolt 1/4-28 x 1-1/4 Gr. 8
63	874 78 06-16	Bolt Fin Hex 3/8-16unc x 1 Gr.5
65	532 16 03-67	Spacer Brace Axle
67	872 14 06-18	Bolt Fin Hex 5/8-11 unc x 2-3/4
68	532 16 98-27	Brace Axle
71	532 17 51-46	Steering Asm
82	532 16 98-35	Bracket Susp Chassis Front
85	532 13 38-35	Fastener Christmas Tree
88	532 17 51-18	Bolt shoulder 7/16-20
91	532 17 55-53	Clip Steering

**NOTE:** All component dimensions given in U.S. inches  
1 inch = 25.4 mm.

# REPAIR PARTS

TRACTOR -- MODEL NUMBER 14596 (BA14596A), PRODUCT NO. 964 77 96-00  
ENGINE

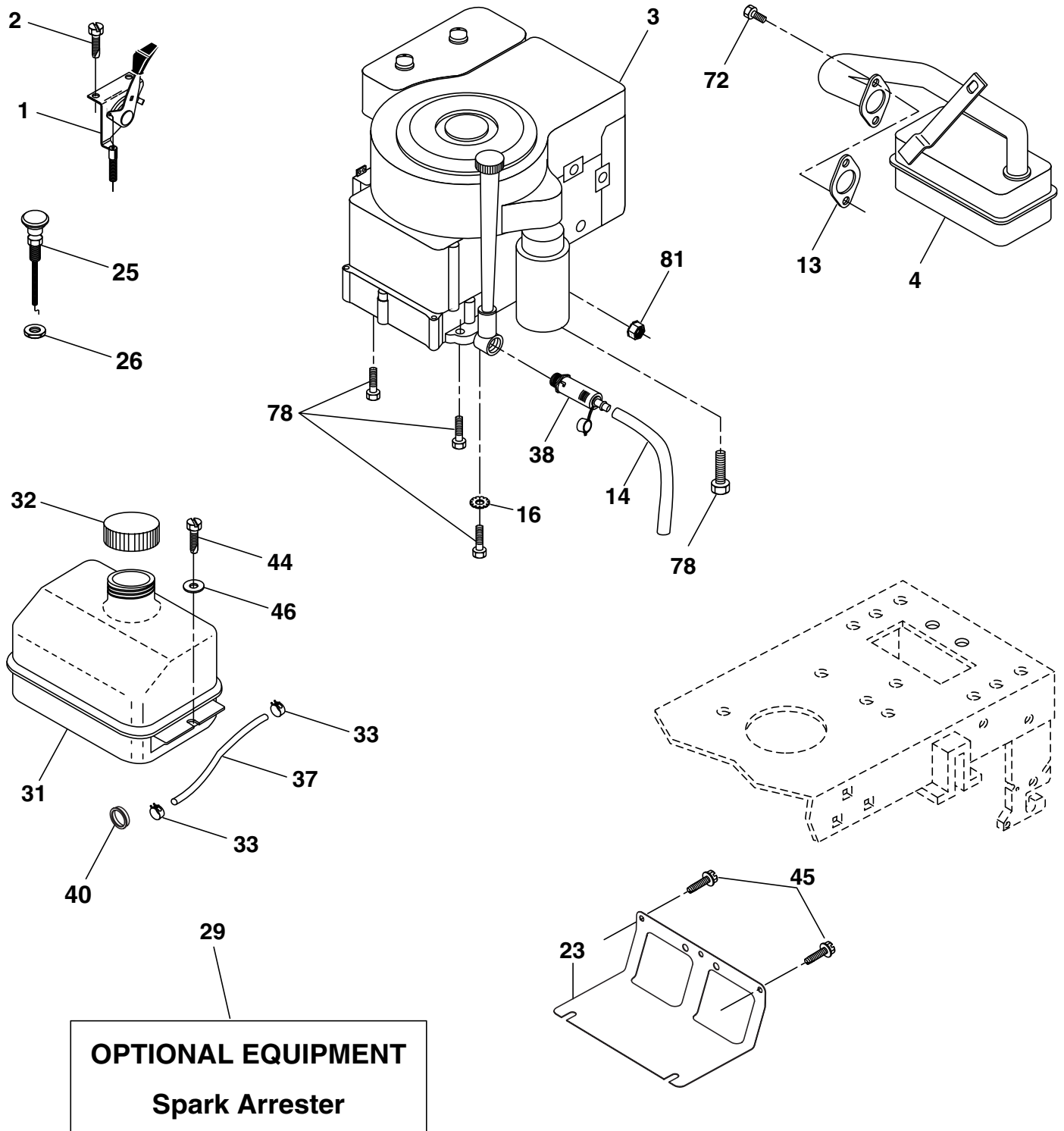

# REPAIR PARTS

## TRACTOR - - MODEL NUMBER 14596 (BA14596A), PRODUCT NO. 964 77 96-00 ENGINE

KEY NO.	PART NO.	DESCRIPTION
1	532 17 05-51	Control Th/ch Flag
2	817 72 04-08	Screw Hex Thd Cut 1/4-20 x 1/2
3	-----	Engine, Briggs 282H07 (Order parts from engine manufacturer)
4	532 13 73-52	Muffler Exhaust
13	532 16 52-91	Gasket Muffler
14	532 14 84-56	Tube Drain Oil Easy
16	811 05 06-00	Washer Lock Ext Tooth 3/8
23	532 16 98-37	Shield BRN/DBR Guard
25	532 18 09-45	Control Choke
26	873 92 06-00	Nut Keps 3/8-24 Unf
29	532 13 71-80	Kit Spark Arrestor (Flat Scrn)
31	532 10 92-02	Tank Fuel Front
32	532 14 05-27	Cap Asm Fuel
33	532 12 34-87	Clamp Hose
37	532 13 70-40	Line Fuel 20"
38	532 18 16-54	Plug Drain Oil Easy
40	532 12 40-28	Bushing Snap NYL BLK Fuel Line
44	817 67 04-12	Screw Thdrol 1/4-20 x 3/4
45	817 00 06-12	Screw Hex Wsh Thdrol 3/8-16
46	819 09 14-16	Washer 9/32 X 7/8 X 16 Ga
72	532 18 39-06	Screw 5/16-18 x 1
78	817 06 06-20	Screw 3/8-16 x 1-1/4
81	873 51 04-00	Nut Keps Hex 1/4-20 Unc

**NOTE:** All component dimensions given in U.S. inches  
1 inch = 25.4 mm

# REPAIR PARTS

TRACTOR - - MODEL NUMBER 14596 (BA14596A), PRODUCT NO. 964 77 96-00  
SEAT

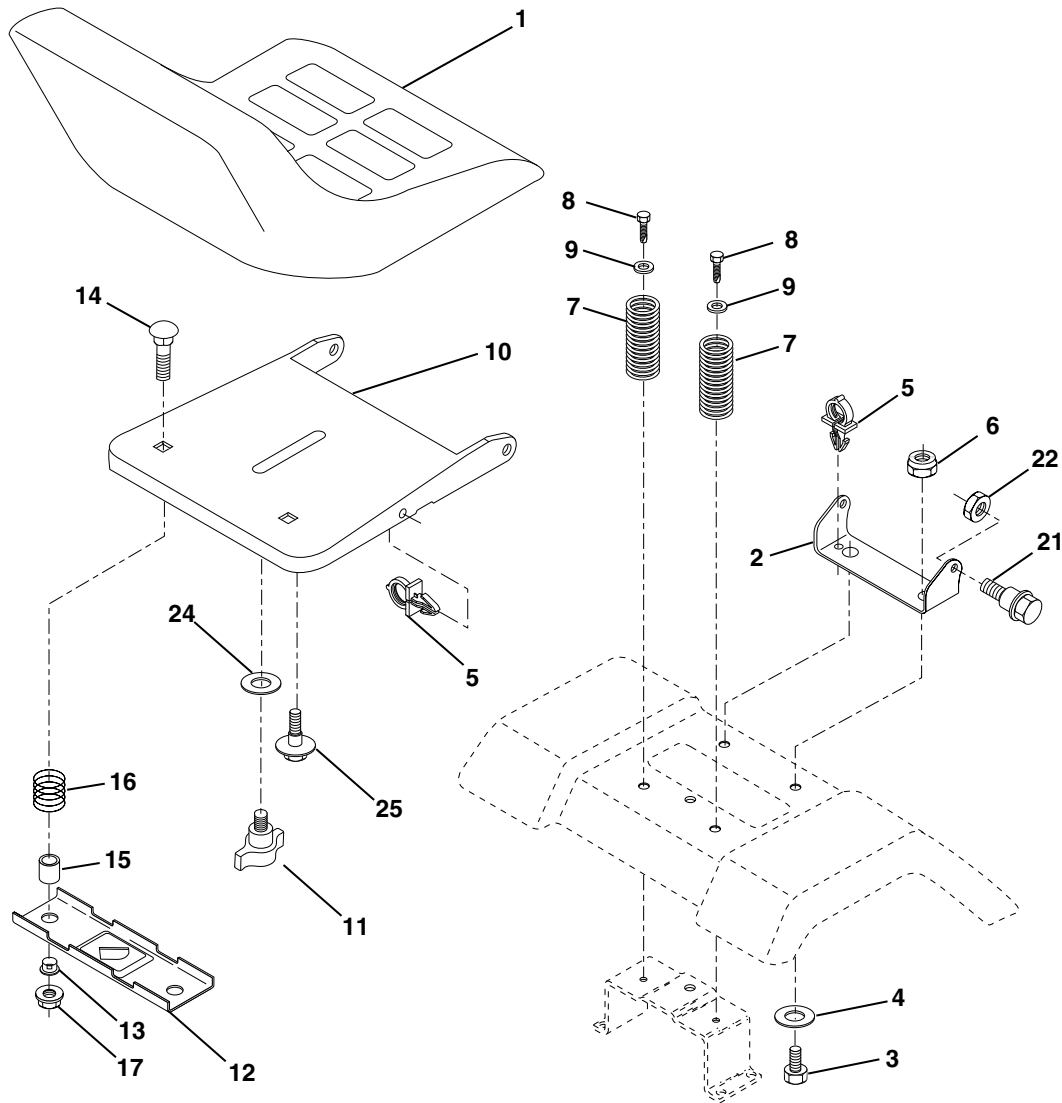

KEY NO.	PART NO.	DESCRIPTION
1	532 12 74-27	Seat
2	532 14 05-51	Bracket Seat Pivot
3	871 11 06-16	Bolt Hex 3/8 - 16 X 1
4	819 13 16-10	Washer 13/32 X 1 X10Ga.
5	532 14 50-06	Clip Push-In Hinged
6	873 80 06-00	Nut Lock Hex w/Ins 3/8 - 16
7	532 12 41-81	Spring Seat Cprsn 2 250 Blk Zi
8	817 00 06-16	Screw 3/8-16 x 1.5
9	819 13 16-14	Washer 13/32 X 1 X 14 Ga
11	532 16 63-69	Knob Seat
10	532 18 24-93	Pan Pnt Seat
12	532 12 12-46	Bracket Pnt Mounting Switch

KEY NO.	PART NO.	DESCRIPTION
13	532 12 12-48	Bushing Snap Blk Nyl
14	872 05 04-12	Bolt Rdhd Sht Nk 1/4 - 20 X 1 -1/2
15	532 13 43-00	Spacer Split .28 X .96
16	532 12 12-50	Spring Cprsn
17	532 12 39-76	Nut Lock 1/4 Lge Flg
21	532 17 18-52	Bolt Shoulder 5/16-18 Unc-2A
22	873 80 05-00	Nut Lock Hex w/Ins 5/16 - 18
24	819 17 19-12	Washer 17/32 X 1-3/16 X 12 Ga
25	532 12 70-18	Bolt Shoulder 5/16-18 X .62

**NOTE:** All component dimensions given in U.S. inches  
1 inch = 25.4 mm.

# REPAIR PARTS

TRACTOR - - MODEL NUMBER 14596 (BA14596A), PRODUCT NO. 964 77 96-00  
DECALS

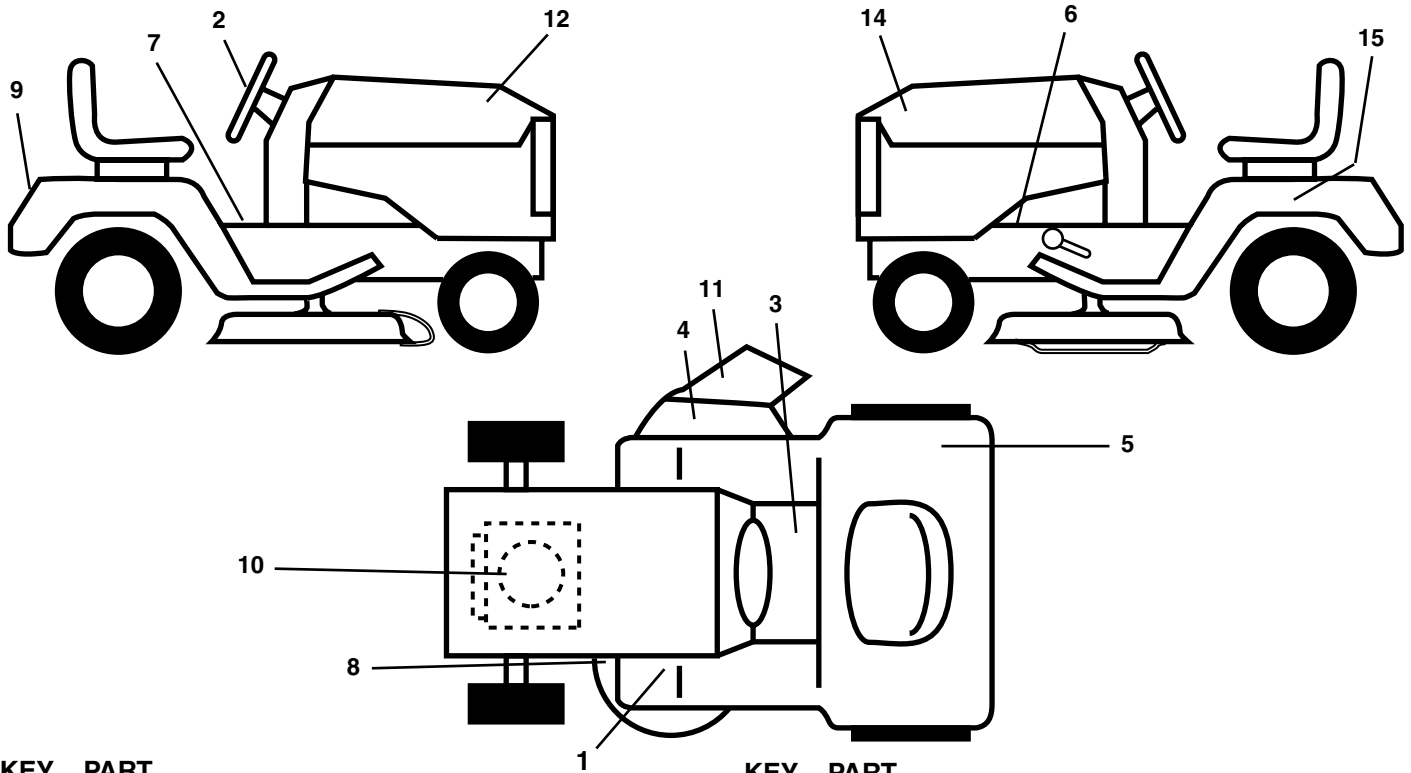

KEY NO.	PART NO.	DESCRIPTION
1	532 15 97-37	Decal, Clutch/Brake
2	532 18 58-80	Decal, Steering Wheel
3	532 14 54-98	Decal, Read Owners Manual
5	532 18 04-32	Decal, Fender 100 DB/CE
6	532 15 97-36	Decal, Hot Muffler
7	532 14 08-37	Decal, Brake Parking Saddle
8	532 13 68-32	Decal, V-Belt Sch.
9	532 18 56-61	Decal, Fender
10	532 18 47-67	Decal Engine

KEY NO.	PART NO.	DESCRIPTION
11	532 18 21-66	Decal Cutfinger
12	532 18 58-68	Decal, Hood RH
14	532 18 58-69	Decal, Hood LH
15	532 14 50-05	Decal, Caution, Battery
--	532 13 83-11	Decal, Handle Lft Height Adj.
--	532 16 25-98	Decal, Draw Bar Load Limit
--	532 18 51-50	Manual E-Bloc
--	532 18 51-49	Manual, Operator's Euro
--	532 18 51-51	Manual, Parts

## WHEELS & TIRES

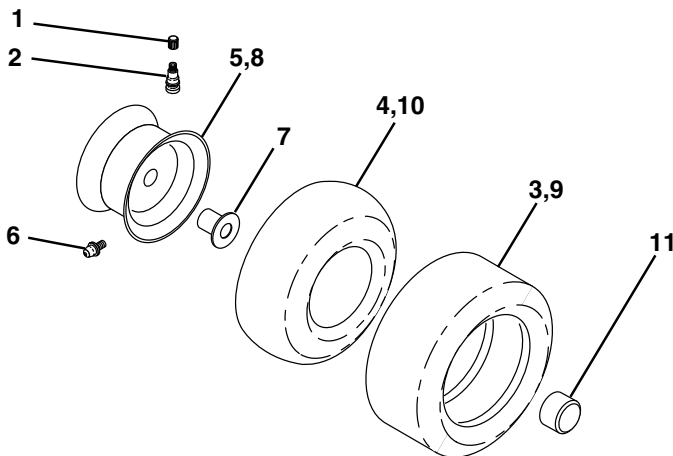

KEY NO.	PART NO.	DESCRIPTION
1	532 05 91-92	Cap, Tire valve
2	532 06 51-39	Stem, Valve
3	532 10 62-22	Tire, Front
4	532 05 99-04	Tube, Front (Service item only)
5	532 18 33-37	Rim assembly, 6" front
6	532 12 49-57	Fitting, Grease (Front wheel only)
7	532 12 49-59	Bearing, Flange (Front wheel only)
8	532 18 33-38	Rim assembly, 8" rear
9	532 12 46-35	Tire, Rear
10	532 12 49-26	Tube, Rear (Service item only)
11	532 17 50-39	Cap, Hub Axle
--	532 14 43-34	Sealant, Tire (10 oz. Tube)

**NOTE:** All component dimensions given in U.S. inches  
1 inch = 25.4 mm

# REPAIR PARTS

TRACTOR - - MODEL NUMBER 14596 (BA14596A), PRODUCT NO. 964 77 96-00  
MOWER LIFT

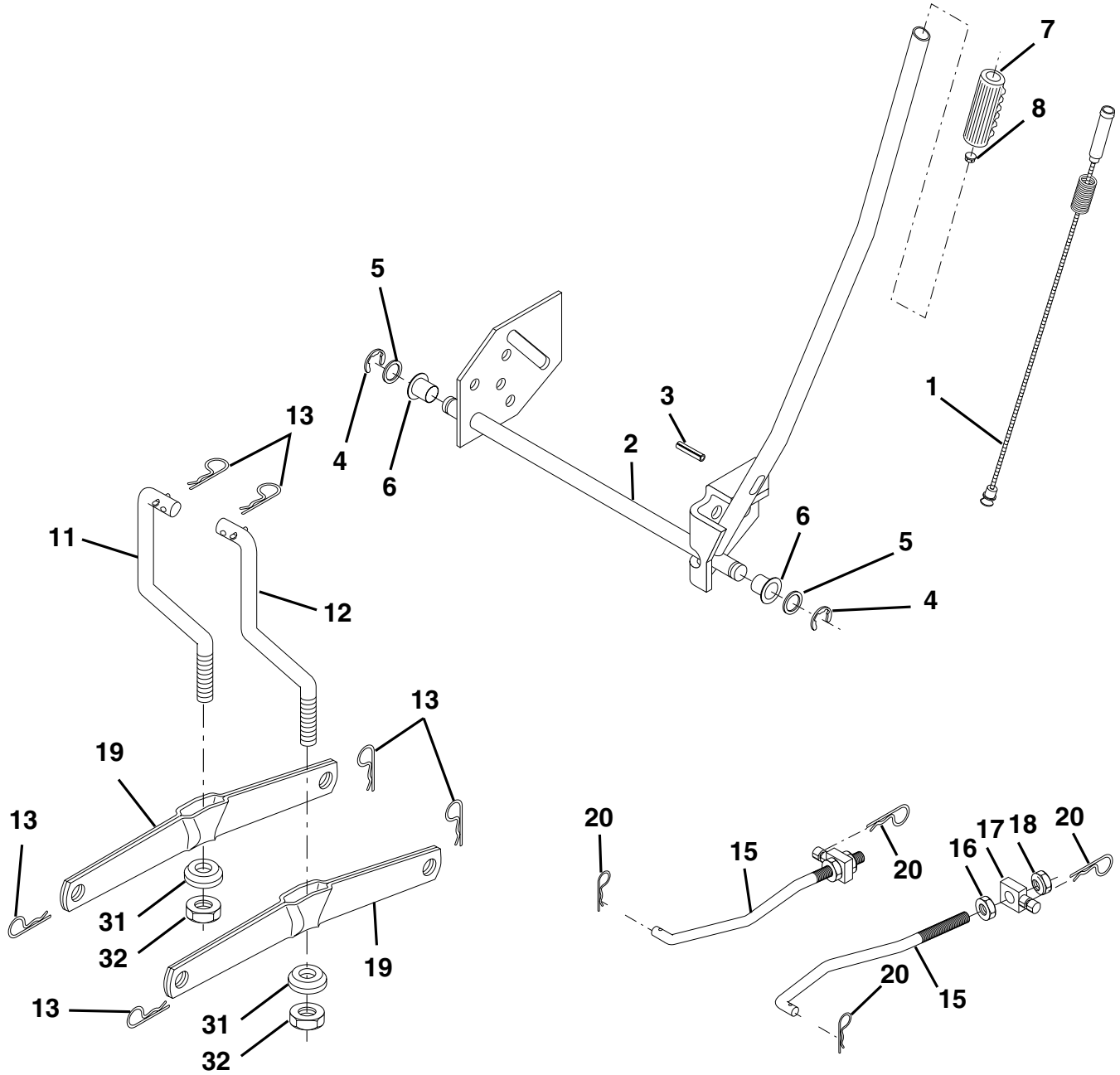



# REPAIR PARTS

TRACTOR - - MODEL NUMBER 14596 (BA14596A), PRODUCT NO. 964 77 96-00  
MOWER LIFT

KEY NO.	PART NO.	DESCRIPTION
1	532 15 94-60	Wire Asm Inner/Sprg w/plunger
2	532 15 94-71	Shaft Asm Lift RH
3	532 10 57-67	Pin Groove 1 500 Zinc
4	812 00 00-02	E Ring #5133-62
5	819 21 16-21	Washer 21/32 X 1 X 21 Ga
6	532 12 01-83	Bearing Nylon Blk 629 Id
7	532 10 94-13	Grip Handle Bicycle Matte Blk
8	532 12 45-26	Button Plunger Black
11	532 13 98-65	Link Lift LH Fixed Length
12	532 13 98-66	Link Lift RH Fixed Length
13	532 12 46-70	Retainer Spring
15	532 17 32-88	Link Front
16	873 35 08-00	Nut Jam Hex 1/2-13 Unc
17	532 17 56-89	Trunnion
18	873 80 08-00	Nut Lockw/Wsh 1/2-13 Unc
19	532 13 98-68	Arm Suspension Rear
20	532 16 35-52	Retainer, Spring
31	532 16 98-65	Bearing Pvt Lift
32	873 54 06-00	Nut Crownlock 3/8-24

**NOTE:** All component dimensions given in U.S. inches  
1 inch = 25.4 mm.

# REPAIR PARTS

TRACTOR -- MODEL NUMBER 14596 (BA14596A), PRODUCT NO. 964 77 96-00  
MOWER DECK

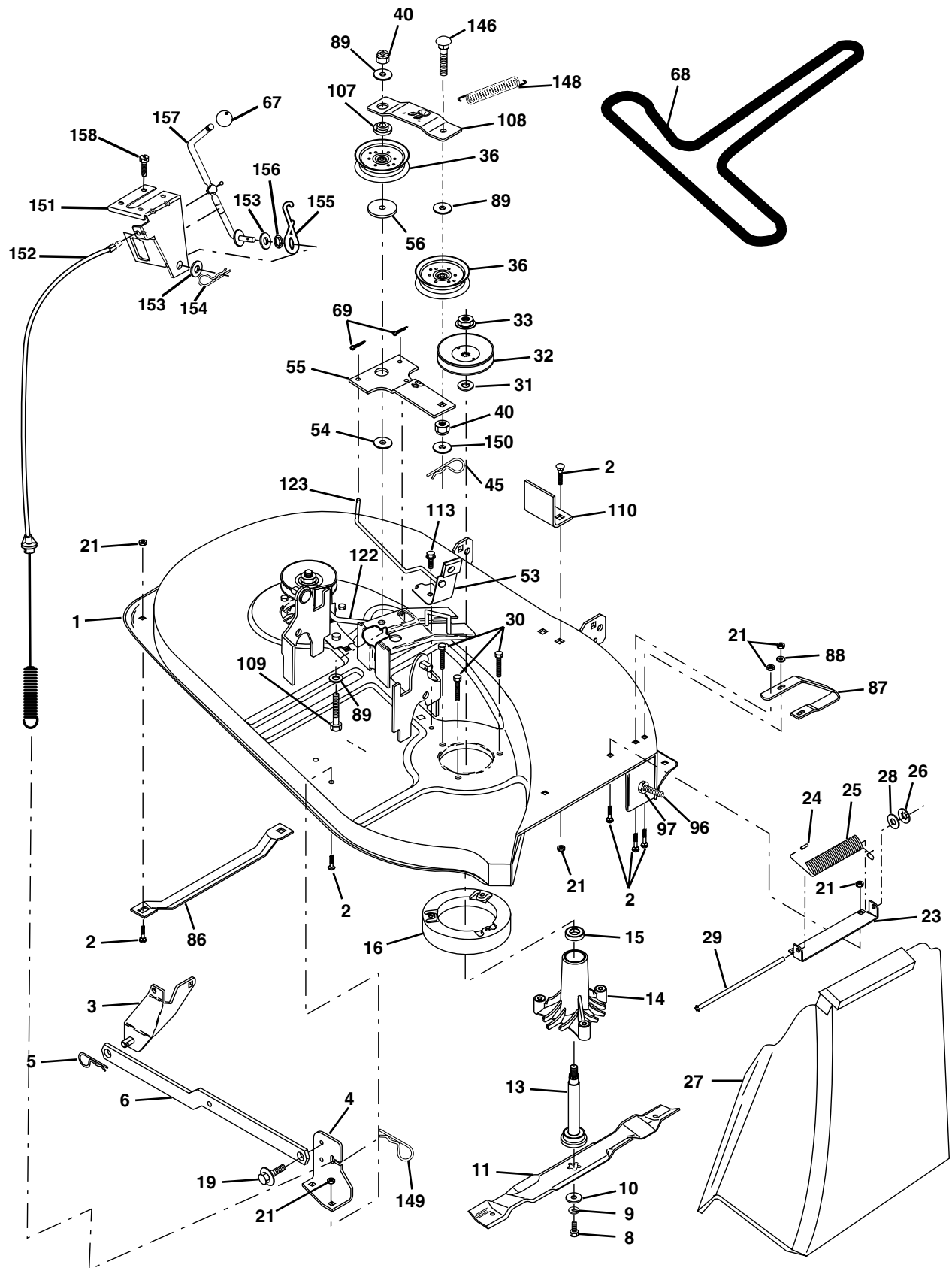

# REPAIR PARTS

## TRACTOR - - MODEL NUMBER 14596 (BA14596A), PRODUCT NO. 964 77 96-00 MOWER DECK

KEY NO.	PART NO.	DESCRIPTION	KEY NO.	PART NO.	DESCRIPTION
1	532 17 02-80	Mower Housing Assembly	67	532 10 69-32	Knob
2	872 14 05-06	Bolt Carriage 5/16-18 x 3/4	68	532 18 02-14	V-Belt
3	532 13 80-17	Bracket Asm Fr. Sway Bar	69	876 02 03-12	Pin, Cotter 3/32 x 3/4
4	532 16 99-70	Bracket Deck Sway Bar 38"/42"	86	532 12 50-74	Runner, LH
5	532 12 46-70	Retainer Spring	87	532 12 87-72	Runner, RH
6	532 17 80-24	Sway Bar Deck	88	819 11 12-16	Washer 11/32 x 3/4 x 16 Ga
8	532 85 08-57	Bolt 3/8-24 x 1.25 Grade 8	89	819 13 16-12	Washer 13/32 x 1 x 12 Ga.
9	810 03 06-00	Washer, Lock 3/8	96	874 93 06-20	Bolt 3/8-16 x 1-1/4
10	532 14 02-96	Washer, Hardened	97	873 93 06-00	Nut Centerlock 3/8-16 Unc
11	532 13 84-97	Blade Mower	107	532 13 35-02	Spacer Retainer
13	532 13 76-45	Shaft Assembly, Mandrel, Vented (Includes Key Number 6)	108	532 13 35-03	Stiffener, Idler Arm
14	532 12 87-74	Housing, Mandrel, Vented	109	874 76 06-40	Bolt, Hex Hd 3/8-16 x 2-1/2
15	532 11 04-85	Bearing, Ball, Mandrel	110	532 14 25-87	Upstop Deck Front 38"
16	532 17 44-93	Stripper, Mower Deck	113	817 06 05-12	Screw 5/16-1/ x 3/4
19	532 13 28-27	Bolt, Shoulder	122	532 13 12-89	Rod, Brake LH
21	873 68 05-00	Nut	123	532 16 99-71	Rod, Brake RH
23	532 13 76-07	Bracket, Mower Deflector	146	532 16 58-91	Bolt Carriage Idler
24	532 10 53-04	Cap, Sleeve	148	532 16 90-22	Spring Return Idler
25	532 12 37-13	Spring, Torsion, Deflector	149	532 16 58-98	Retainer Spring Yellow
26	532 11 04-52	Nut, Push	150	819 09 12-16	Washer 9/32 x 3/4 x 16 Ga.
27	532 17 59-43	Shield, Deflector	151	532 16 96-70	Bracket Clutch Cable
28	819 11 10-16	Washer 11/32 x 5/8 x 16 Gauge	152	532 17 27-58	Clutch Cable 38"/46"
29	532 10 67-35	Rod, Hinge	153	532 16 96-74	Washer Flat 3/8" Type B
30	532 17 39-84	Screw Thdrol. Hex	154	532 16 96-75	Spring Retainer
31	532 12 99-63	Washer, Spacer	155	532 16 96-71	Spring Retention LVR CLTCH CAB
32	532 15 35-32	Pulley, Mandrel	156	532 16 96-72	Spacer Clutch Cable
33	532 17 83-42	Nut, Toplock	157	532 16 96-69	Rod Clutch Cable 3/8"
36	532 13 14-94	Pulley, Idler, Flat	158	817 72 04-08	Screw Hex Thd Cut 1/4-20 x 5/8
40	873 68 06-00	Nut, Crownlock 3/8-16 Unc	--	532 13 07-94	Mandrel Assembly (Includes Housing, Shaft, and Shaft Hardware Only - Pulley Not Included)
45	532 12 47-88	Retainer	--	532 18 13-80	Mower Replacement, Complete
53	532 13 08-40	Brake Assembly			
54	532 17 85-15	Washer, Hardened			
55	532 13 38-40	Idler Arm Assembly			
56	532 16 57-23	Spacer, Retainer			

**NOTE:** All component dimensions given in U.S. inches  
1 inch = 25.4 mm

## **Electrolux Outdoor Products Service Contacts**

### **BELGIQUE/BELGIË**

Electrolux Outdoor Products  
Tel: 02 363 0311, Fax: 02 363 0391

### **ČESKÁ REPUBLIKA**

Electrolux, spol. S.r.o., oz Electrolux Outdoor Products,  
Na Krecku 365 Praha 10 - Horní Mecholupy  
Tel: 02/7487 0164, Info-linka: 0800/110 220  
Internet: www.partner-flymo.cz E-mail: info@husqvarna.cz

### **DANMARK**

Electrolux Outdoor Products, Flymo/Partner A/S,  
Lundtoftegaardsvej 93A, DK 2800 Kgs.Lyngby  
Tel: 45 87 75 77, Fax: 45 93 33 08 www.flymo-partner.dk

### **DEUTSCHLAND**

Electrolux Outdoor Products  
Tel: 097 21 7640, Fax: 097 21 764202

### **ESTONIA**

Electrolux Estonia Ltd (Electrolux Eesti AS)  
Tel: (372) 6650010

### **FRANCE**

Electrolux Outdoor Products  
Tel 01 46 67 8141, Fax 01 43 34 2491

### **FINLAND SUOMI**

Electrolux Outdoor Products Finland  
Tel: 00 39611, Fax: 00 39 612632

### **ITALIA**

McCulloch Italiana s.r.l. - Via Como 72, 23868 Valmadrera  
(LECCO) - ITALIA, Tel: 800 017829, Fax: 0341 581671

### **IRELAND**

Electrolux Outdoor Products  
Tel: 01 4565222, Fax: 01 4568551

### **MAGYARORSZÁG**

Electrolux Lehel Kft  
Tel: 00 36 1 251 41 47

### **NORGE**

Electrolux Outdoor Products  
Tel: 69 10 47 90

### **NEDERLAND**

Electrolux Outdoor Products BV  
Tel: 0172-468322, Fax: 0172-468219

### **ÖSTERREICH**

HUSQVARNA Zentralwerksttte, Industriezeile 36, 4020 LINZ,  
Tel: 0732 770101-60, Fax: 0732 795922

### **POLSKA**

Electrolux Poland Sp. z.o.o. Husqvarna, 01-612 Warszawa  
Myslowicka 10/2  
Tel:- (22) 8332949

### **SLOVENIJA**

HUSQVARNA-Ges.m.b.H. Nfg. KG, Industriezeile 36, 4020 LINZ,  
Tel: 0732 77 01 01-0, Fax: 0732 77 01 01.40  
Internet: www.husqvarna.at E-mail: office@husqvarna.co.at

### **SLOVENSKA**

Electrolux Slovakia s.r.o., Borova Sihot 211, 033 01 Lipt. Hradok  
Tel: 044 522 14 19, Fax: 044 522 14 18, www.flymo-partner.sk

### **SCHWEIZ/SUISSE/SUIZZERA**

Electrolux Outdoor Products  
Tel 062 889 93 50 / 889 94 25, Fax 062 889 93 60 / 889 94 35

### **SVERIGE**

Electrolux Outdoor Products, Sverige  
Tel: 036 û 14 67 00, Fax: 036 û 14 60 70

### **UNITED KINGDOM**

Electrolux Outdoor Products, United Kingdom  
Tel: 01325 300303, Fax: 01325 310339

