

Model 1P85FA–352cc Service Manual

General	1-1
California	
Proposition 65 Warning	1-1
How to Use This Manual	1-1
Table of Contents	1-1
Quick Reference Specifications	1-1
Warnings and Cautions	1-1
Note and Important	1-1
Troubleshooting	1-1
Introduction	1-1
Prepare for the Job	1-1
Safety Notices	1-1
Keep Work Area Clean	1-2
Keep Work Area Well Ventilated	1-2
Use Proper Eye and Face Protection	1-2
Store Volatile and Hazardous Materials Safely	1-2
Dispose of Waste Materials Safely	1-2
Safety Rules	1-3
General Service	1-4
Prepare for Service	1-4
Identification	2-1
Model Number and Serial Number	2-2
Dimensional Drawings	2-3
Specifications	2-4
Quick Reference Guide	2-4
Engine	2-4
Weights and Dimensions	2-4
Fastener Torque Values	2-5
Maintenance Schedule	3-1
Engine Oil	3-2
Air Filter	3-3
Spark Plug	3-3
Valve Clearance	3-4
Carburetor and Idle Speed	3-5
Governor Adjustment	3-5
Service Guidelines	4-1
Air Filter Assembly Components	4-2
Engine Cover Components	4-2
Control Lever Components	4-3
Carburetor Components	4-3
Governor	4-4



Ignition Coil	4-4
Inspection	4-5
Flywheel and Fan	4-6
Removal and Installation	4-8
Disassembly and Assembly	4-8
Valve Spring Free Length	4-9
Valve Seat Width	4-9
Cylinder Head	4-9
Valve Stem O.D.	4-9
Valve Guide I.D.	4-10
Valve Stem to Valve Guide Clearance	4-10
Cylinder Head Service	4-11
Exhaust Valve Guide Replacement	4-11
Exhaust Valve Guide Reaming	4-11
Valve Seat Reconditioning	4-12
Valve Seat Width	4-12
Valve Lapping	4-13
Crankshaft, Piston and Camshaft	4-13
Disassembly	4-14
Assembly	4-14
Crankcase Cover	4-14
Piston, Rings, and Connecting Rod	4-15
Disassembly	4-15
Assembly	4-16
Cylinder Bore Measurement	4-16
Measuring Cylinder Bore Taper	4-16
Cylinder Bore Service Wear Limit	4-17
Piston Skirt Outside Diameter	4-17
Piston to Cylinder Clearance	4-17
Piston Pin	4-18
Piston Ring Width	4-18
Piston Ring End Gap	4-18
Piston Ring Side Clearance	4-18
Connecting Rod Small End I.D.	4-19
Connecting Rod Big End I.D.	4-19
Crankshaft Rod Journal O.D.	4-19
Connecting Rod Big End Side Clearance	4-19
Connecting Rod Big End Oil Clearance (Radial)	4-20
Camshaft Cam Lobe Height	4-20
Camshaft Journal Diameter	4-20
Hard to Start	5-1
Overheating	5-2
Poor Engine Performance	5-2
Starter Motor Troubleshooting Guide	5-3

1

2

3

4

5

Check for Spark	5-4
Check Cylinder Compression	5-4

1

2

3

4

5

1

2

3

4

5

Foreword

General

This manual provides detailed information and procedures to safely repair and maintain the following:

Husqvarna 1P85FA 352CC gasoline engine.

This manual is intended to introduce and guide the user through the latest factory-approved troubleshooting and repair techniques and practices.

Before you attempt to troubleshoot or make repairs, you must be familiar with the operation of the machine and engine. Refer to the machine operator's manual and parts manual for specific information on these topics.

THE INFORMATION CONTAINED IN THIS MANUAL IS BASED ON ENGINES MANUFACTURED UP TO THE TIME OF PUBLICATION. HUSQVARNA RESERVES THE RIGHT TO CHANGE ANY OF THIS INFORMATION WITHOUT NOTICE.

California Proposition 65 Warning



WARNING

Certain vehicle components contain or emit chemicals known to the State of California to cause cancer and birth defects or other reproductive harm.

How to Use This Manual

This manual is designed to provide multiple ways to locate and access repair information.

Read each section in entirety before beginning a procedure. Proper understanding of machine, engine operation and components is the key to successful diagnostics and repair.

Make use of special information features within this manual in order to be better prepared to perform repairs. Always follow manual procedures and safety guidelines. Never take shortcuts.

Table of Contents

Major topics of interest are separated into specific chapters. Each manual lists these chapters in a main Table of Contents.

Quick Reference Specifications

A list of all specifications can be found in Chapter 2 Specifications. This listing contains:

- Engine Model and Serial Number Identification
- Engine Specifications
- Torque Values

Warnings and Cautions

Warning and Caution indicators are located throughout the manual at specific points of interest. These notices are given to prevent personal injury, death, and/or equipment damage. Always heed these notices and practice common sense when performing any maintenance or repair procedure.

Note and Important

Special notes are given in order to draw attention to detailed instructions. These notes are intended to give further important information regarding the step in a procedure.

Troubleshooting

Troubleshooting charts are provided to aid in the diagnostic process. Use these suggestions to aid in identifying potential problems.

Introduction

Safety is an important element in any repair procedure. Knowledge of the procedure to be performed and safe work habits are essential to preventing death, personal injury, or property damage. Use the following statements as a common-sense guide to proper work and tool-use habits.

Prepare for the Job

Preparation is essential to complete a procedure in a safe and efficient manner.

- Wear proper clothing. Loose or baggy clothing could become tangled.
- Use eye and face protection. Always use proper eye and face protection to protect your eyes from flying debris or chemical splatters.
- Wear protective footwear. Wear safety shoes to protect your feet from falling objects.
- Always use the correct tool for the procedure. Improper or homemade tools can cause injury or machine damage.
- Gather the needed parts and materials before beginning the procedure.
- Allow machine to cool. Machine can get hot during operation. Be sure to allow enough time for components to cool before servicing the machine.
- Perform service in a well-lit work area. A well-lit work area can make the job easier and safer.
- Always follow procedures and safety warnings. Service procedures are written to be as safe and efficient as possible. Never take shortcuts.
- Be prepared for emergencies. Accidents can happen, even under the best conditions. Fire extinguishers and first aid kits should be well maintained and easily accessible.

Safety Notices

Throughout this manual, the following key safety words will be used to alert the reader of potential hazards. Become familiar with these words and their meaning. Take all precautions to avoid the hazards described.



This safety alert symbol is used to alert you to important safety precautions.



DANGER

Indicates an imminently hazardous situation which, if not avoided, **WILL** result in death or serious injury.



WARNING

Indicates a potentially hazardous situation which, if not avoided, **COULD** result in death or serious injury.



CAUTION

Indicates a potentially hazardous situation which, if not avoided, **MAY** result in minor or moderate injury and property damage. It may also be used to alert against unsafe practices.

NOTICE

Indicates a potentially hazardous situation which, if not avoided, **MAY** result in property damage. It may also be used to alert against unsafe practices.

Keep Work Area Clean

To promote safe working conditions, keep a clean, organized, and well-lit work area.

- Keep debris, parts, and tools off the floor.
- Immediately clean up any spilled fuel or oil.

1 Keep Work Area Well Ventilated



WARNING

Never operate the engine without proper ventilation; exhaust fumes can be fatal if inhaled.

Be sure work area is well ventilated; never run the engine in an enclosed area.

Use Proper Eye and Face Protection



WARNING

Always use approved eye and face personal protection equipment. Failure to use appropriate protection equipment may result in death or serious injury.

Always wear eye protection while in a shop environment.

- Safety Glasses: Minimum level of protection from flying debris.
- Face Shields: Face shields are often used along with safety glasses to offer a higher level of protection when sparks and flying debris are present.
- Vented Goggles: Side protection not offered by safety glasses alone.
- Unvented Goggles: Protection from chemical splashes and vapors.

Store Volatile and Hazardous Materials Safely

Store volatile materials (gasoline, oil, etc.) in approved containers that are clearly marked. Containers should be stored in an approved safety cabinet away from possible sources of ignition. Storage areas and cabinets should be well ventilated to prevent the possible buildup of fumes.

Dispose of Waste Materials Safely

NOTICE

Waste materials not handled properly can pose a threat to the environment. Collect fluids in well-marked, approved storage containers.

Some waste fluids can react with certain types of plastics. Make sure the fluid to be stored is compatible with the storage container. Never use food or beverage containers to store waste fluids.

IMPORTANT

Never dispose of waste fluids by pouring on the ground, down sewer drains, or into any body of water.

Dispose of waste fluids properly at approved local recycling centers. If recycling facilities are not available, contact your local community for the correct disposal procedure for waste fluids.

Safety Rules



WARNING

In order to prevent accidental starting when setting up, transporting, adjusting, or making repairs, always disconnect spark plug wire and place wire where it cannot come in contact with plug.



CAUTION

Engine components will become hot during operation. Use caution when working near engine components while performing service. Failure to follow safety recommendations may result in injury.



WARNING

Engine exhaust, some of its constituents, and certain vehicle components contain or emit chemicals known to the State of California to cause cancer and birth defects or other reproductive harm. Always operate engine with proper ventilation.



WARNING

Battery posts, terminals, and related accessories contain lead and lead compounds, chemicals known to the State of California to cause cancer and birth defects or other reproductive harm. Wash hands after handling.

In the state of California, the above is required by law (Section 4442 of the California Public Resources Code). Other states may have similar laws. Federal laws apply on federal lands. A spark arrester for the muffler is available through your nearest authorized service center.

Handle fuel with care—it is highly flammable.



WARNING

Gasoline is extremely flammable, and the vapors are explosive. To avoid personal injury or property damage, carefully read and follow all of the safety instructions.

- Never remove the fuel cap or add fuel when the engine is running or while the engine is hot.
- Do not smoke when handling fuel.
- Do not fill above the fuel filler neck.
- Never overfill or allow the tank to become empty.
- Make sure to reinstall and tighten fuel cap securely.
- Never fill or drain the fuel tank indoors.
- Do not spill fuel. Clean spilled fuel immediately.
- If fuel is spilled on clothing, change clothing immediately.
- Never handle or store fuel containers near an open flame or any device that may create sparks and ignite the fuel or fuel vapors.
- Use an approved container; the spout must fit inside the fuel filler neck. Avoid using cans and funnels to transfer fuel.
- Never fill containers inside a vehicle or on a truck or trailer bed with a plastic liner. Always place containers on the ground away from your vehicle before filling.
- Remove gas-powered equipment from the truck or trailer and refuel it on the ground. If this is not possible, then refuel such equipment with a portable container, rather than from a gasoline dispenser nozzle.
- Keep the nozzle in contact with the rim of the fuel tank or container opening at all times until fueling is complete.
- Do not use a nozzle lock-open device.
- Store fuel according to local, state, or federal ordinances.
- To help reduce fuel related engine operating concerns, do not use fuel older than 30-45 days old after fuel purchase.

General Service



WARNING

Operator can be seriously injured or killed by this equipment. To avoid personal injury or possible death, carefully read and follow all of the safety instructions.

- Never run a machine inside a closed area.
- Never make adjustments or repairs with the engine (motor) running. Disconnect spark plug wire and keep wire away from plug to prevent accidental starting.
- Keep nuts and bolts, especially blade attachment bolts, tight and keep equipment in good condition.
- Do not change the engine governor setting or overspeed the engine.
- Maintain or replace safety and instruction labels, as necessary.

Prepare for Service



WARNING

In order to prevent accidental starting when setting up, transporting, adjusting, or making repairs, always disconnect spark plug wire and place wire where it cannot come in contact with plug.

Disconnect spark plug wire from spark plug and place the wire where it cannot come in contact with plug.

Identification

Table 2-1: General Engine Specifications

Model	1P85FA
Type	Single Cylinder, 4-Stroke, Air Cooled, OHV
Max. Power	7.2 kW (3,600 rpm) (5.369 hp)
Max. Torque	21 Nm (15.488 ft-lb) at 2,400 rpm
Fuel Consumption	≤ 395 g/kW•h
Idle Speed	1850±150 rpm
Bore X Stroke	85×62 mm (3.346 x 2.44 in.)
Displacement	352 cc (21.48 cu-in)
Compression Ratio	8.7:1
Lubricating Mode	Splash
Starting Mode	Electric
Rotation	Counterclockwise (from P.T.O. side)
Valve Clearance	Intake Valve: 0.10 ± 0.02 mm (0.0039 in. ± 0.00787 in.) Exhaust Valve: 0.15 ± 0.02 mm (0.0059 in. ± 0.00787 in.)
Spark Plug Gap	0.7 - 0.8 mm (0.028-0.031 in.)
Ignition	Transistorized Magneto
Air Cleaner	Foam & Paper
Fuel Type	Unleaded Gasoline, Minimum 90 Octane with no more than 10% ethanol
Oil Capacity	0.8 L (27.05 oz)
Dimension (LxWxH) (mm)	404.5×376×388 mm (15.9 x 14.8 x 15.275 in.)
Net Weight	24.0 kg (52.9 lb.)

Model Number and Serial Number

The model and serial number (1) is located as shown on the engine crankcase.

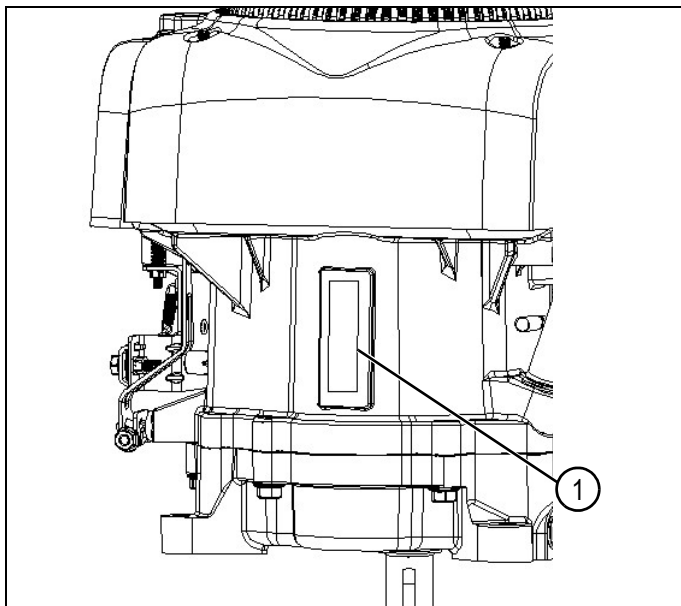

Figure 2-1: Model and Serial Number Location

Always provide the serial number and model number of the machine when ordering replacement parts or requesting service information.

Dimensional Drawings

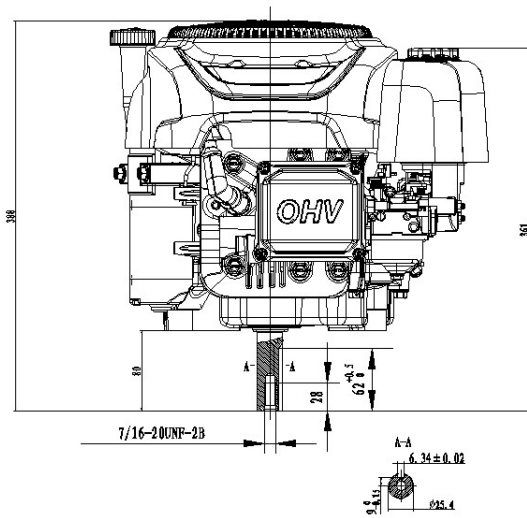

Figure 2-2: Front Engine View

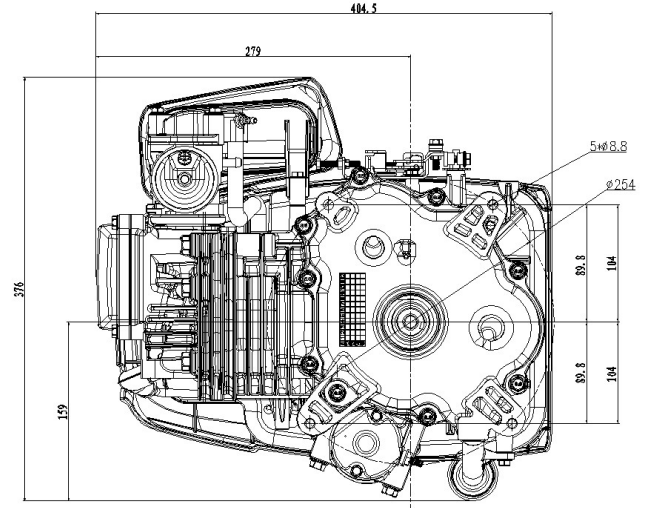

Figure 2-4: Bottom Engine View

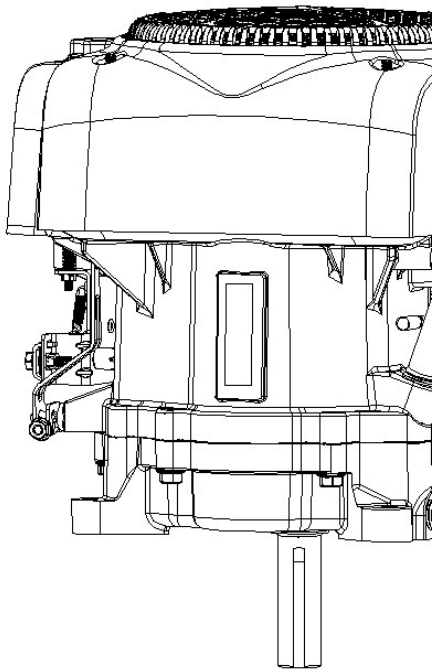

Figure 2-3: Rear Engine View

2

SPECIFICATIONS

Specifications

Quick Reference Guide

Specifications	
Fuel	Unleaded Gasoline, Minimum 90 Octane with no more than 10% ethanol
Engine Oil	SAE 10W-30, API SJ or later
Spark Plug	BCPR6ES (NGK) RC12YC (Champion)
Spark Plug Gap	0.028–0.031 in. (0.70–0.80 mm)
Valve Clearance (cold)	Intake: 0.004 ± 0.001 in. (0.10 ± 0.02 mm) Exhaust: 0.006 ± 0.001 in. (0.15 ± 0.02 mm)

Engine

Specifications	
Engine Manufacturer	Husqvarna
Engine Name	1P85FA (3,200 rpm)
Cylinder Displacement	352 cc (21.48 cu-in)
Bore x Stroke	85×62 mm (3.7795 x 3.307 in.)
Maximum Power and Torque at RPM	7.2 kW (5.369 hp) at 3,600 rpm 21 Nm (15.488 ft-lb) at 2,400 rpm
Valve Clearance (cold)	Intake: 0.004 ± 0.001 in. (0.10 ± 0.02 mm) Exhaust: 0.006 ± 0.001 in. (0.15 ± 0.02 mm)
Power	7.2 kW (5.369 hp)
Engine Type	4-stroke, Overhead Valve, Single Cylinder
Engine Oil	SAE 10W-30, API SJ or later
Engine Oil Capacity	0.8 L (27.05 oz.)
Fuel	Unleaded Gasoline, Minimum 90 Octane with no more than 10% ethanol
Fuel Consumption	≤ 395 g/kW•h
Spark Plug	BCPR6ES (NGK) RC12YC (Champion)
Spark Plug Gap	0.028–0.031 in. (0.70–0.80 mm)
Cooling System	Air Cooled
Ignition System	Transistorized Magneto
PTO Shaft Rotation	Counterclockwise (from P.T.O. side)

* Actual amount will vary due to residual engine oil remaining in the engine. Always use the oil fill/dipstick to confirm the actual engine oil level.

Weights and Dimensions

Specifications	
Weight (engine only)	24 kg (52.9 lb.)

Fastener Torque Values

	Bolt Specification	Torque Value (SAE)	Torque Value (Metric)
Oil Drain Plug Assembly	Oil Drain Plug	13~17 ft-lb	18~23 Nm
Spark Plug	M14x1	20~22 ft-lb	27~30 Nm
Connecting Rod Cover	Six Hexagonal Flange Bolt M7×47	8~10 ft-lb	11.5~13.5 Nm
Crankcase Cover Bolt	Six Hexagonal Flange Bolt M8×50	18~21 ft-lb	24~28 Nm
Fuel Pump Assembly	Six Hexagonal Flange Bolt M6×16	6~9 ft-lb	8~12 Nm
Breather Valve Assembly	Six Hexagonal Flange Bolt	6~9 ft-lb	8~12 Nm
Cylinder Head	Six Hexagonal Flange Bolt M10x1.5x65	37~41 ft-lb	50~55 Nm
	Six Hexagonal Flange Bolt M8x50	22~26 ft-lb	30~35 Nm
Push Rod Location Limit Plate	Valve Adjust Stud	21~24 ft-lb	28~32 Nm
Valve Lash Inspection (Q1)	Valve Lock Nut M6	9~12 ft-lb	12~16 Nm
Valve Cover	Six Hexagonal Flange Bolt – M6x25	7~9 ft-lb	10~12 Nm
Flywheel	Six Hexagonal Flange Bolt – M12x35	66~85 ft-lb	90~115 Nm
Ignition Coil	Six Hexagonal Flange Bolt – M6x22	6~9 ft-lb	8~12 Nm
Electric Starter Motor	Six Hexagonal Flange Bolt – M8x80	16~22 ft-lb	22~30 Nm
Carburetor Assembly		6~9 ft-lb	8~12 Nm
Throttle Assembly Choke Bracket Assembly		6~9 ft-lb	8~12 Nm
Fan Shroud	Six Hexagonal Flange Nut – M6-16	6~9 ft-lb	8~12 Nm
Ignition Coil	Six Hexagonal Flange Bolt – M6x20	6~9 ft-lb	8~12 Nm
Oil Filter	–	6~9 ft-lb	8~12 Nm
Carburetor Solenoid Valve	M-12	7~8 ft-lb	9~11 Nm

SPECIFICATIONS

Part	Item	Standard	Service Limit
Engine	Compression Pressure (kg/cm2)*	8.7 kg/cm2* (123.7 psi)	8.0kg/cm2 (113 psi)
Cylinder Head	Warpage	—	0.1 mm (0.004 in.)
Cylinder	Sleeve (Inside Diameter X)	85~85.01 mm (3.346~3.347 in.)	85.1 mm (3.35 in.)
	Sleeve (Inside Diameter Y)	85~85.01 mm (3.346~3.347 in.)	85.1 mm (3.35 in.)

2

Part	Item	Standard	Service Limit
Piston	Skirt (Outside Diameter)	84.965~84.975 mm (3.3450~3.3455 in.)	84.94 mm (3.344 in.)
	Clearance to Cylinder	0.025~0.045 mm (0.0010~0.0018 in.)	0.081 mm (0.0032 in.)
	Piston Pin Bore (Inside Diameter)	20.002~20.008 mm (0.7875~0.7877 in.)	20.01 mm (0.7878 in.)
	Piston - Pin Clearance	0.004~0.016 mm (0.00016~0.00063 in.)	0.029 mm (0.00114 in.)
Piston Pin	Outside Diameter	19.992~19.998 mm (0.7871~0.7873 in.)	19.9 mm (0.7834 in.)
Piston Ring	Side Clearance (Top/The Second)	0.02~0.06 mm (0.0008~0.0024 in.)	0.11 mm (0.0043 in.)
	End Gap (Top)	0.2~0.35 0.0079~0.0138 in.)	0.4 mm (0.016 in.)
	End Gap (The Second)	0.3~0.45 mm (0.012~0.018 in.)	0.5 mm (0.020 in.)
	Width (Top/Second)	1.17~1.19 mm (0.046~0.047 in.)	1.1 mm (0.043 in.)
	Width (Oil Ring)	1.88~1.95 (0.074~0.077 in.)	1.7 mm (0.067 in.)
Connecting Rod	Small End Inside Diameter	20.006~20.017 mm (0.787~0.788 in.)	20.02 mm (0.7882 in.)
	Big End Inside Diameter	36.02~36.04 mm (1.4181~1.4189 in.)	36.05 mm (1.4193 in.)
	Big End Side Clearance	0.03~0.35 mm (0.0012~0.0138)	0.4 mm (0.016 in.)
Crankshaft	Crankpin Outside Diameter	34.966~34.981 mm (1.376~1.377 in.)	34.946 mm (1.375 in.)
Valve	Clearance (Cold) (Intake)	0.10 ± 0.02 mm (0.004± 0.001 in.)	—
	Clearance (Cold) (Exhaust)	0.15 ± 0.02 mm (0.004± 0.001 in.)	—
	Stem Diameter (Intake)	6.565~6.58 mm (0.2585~0.2591 in.)	6.55 mm (0.2579 in.)
	Stem Diameter (Exhaust)	6.545~6.56 mm 0.2576~0.2583 in.)	6.53 mm (0.2571 in.)
Valve Guide	Inside Diameter (Intake, Exhaust)	6.6~6.615 mm (0.2598~0.2604 in.)	6.62 mm (0.2606 in.)
	Stem to Guide Clearance (Intake)	0.02~0.05 mm (0.0008~0.0020 in.)	0.12 mm (0.0047 in.)
	Stem to Guide Clearance (Exhaust)	0.04~0.07 mm (0.0016~0.0027 in.)	0.17 mm (0.0067 in.)
Valve Seat	Seat Width	0.8~1.0 mm (0.03~0.039 in.)	1.5 mm (0.059 in.)
Valve Spring	Free Length	39.5~40.5 mm (1.555~1.594 in.)	39 mm (1.535 in.)

2

SPECIFICATIONS

Part	Item	Standard	Service Limit
Camshaft	Height (Intake)	32.535~32.635mm (1.281~1.285 in.)	32.4 mm(1.276 in.)
	Height (Exhaust)	32.018~32.118 mm (1.261~1.264 in.)	31.9 mm (1.256 in.)
	Outer Diameter (Bearing)	15.966~15.984 mm (0.628~0.629 in.)	15.916 mm (0.626 in.)
Crankcase Cover	Camshaft Hole Diameter	16~16.018 mm (0.630~0.631 in.)	16.1 mm (0.634 in.)
	Crankshaft Hole Diameter	35.009~35.025 mm (1.378~1.379 in.)	34.9mm (1.374 in.)
Spark Plug	Gap	0.7~0.8 mm (0.027~0.031 in.)	—
Ignition Coil	Resistance (Primary)	1.2Ω	—
	Resistance (Secondary)	5.5k Ω	—
	Gap to Flywheel	0.4 mm (0.016 in.)	—

2

Maintenance Schedule

Maintenance Schedule		Each Use	First Month or 5-Hours	Every 3-Months of 25-Hours	Every 6-Months or 50-Hours	Every Year or 100-Hours	Every 2-Years or 200-Hours	Every 300-Hours
Engine Oil	Check	•						
	Replace		•			•		
Air Cleaner Element	Check	•						
	Clean			•(1)				
	Replace					•(1)		
Oil Filter	Replace		•			•		
Fuel Filter	Replace					•		
Spark Plug	Clean and Adjust					•		
	Replace							•
Valve Clearance	Check and Adjust						•(2)	
Combustion Chamber	Clean							•(2)
Fuel Tube	Replace	Every 2-Years (Replace if necessary) (2)						

(1) Service more frequently when used in dusty conditions.

(2) These items are to be maintained by designated dealers unless the user has special tools and skills for maintenance.

Engine Oil

Drain oil while engine is warm to allow rapid and complete draining.

NOTES

Use a high-detergent, premium quality 4-stroke engine oil certified to meet or exceed U.S. automobile manufacturer requirements for API Service Classification SG, SF. SAE 15W-40 is recommended for general, all-temperature use. All other viscosities shown in the chart may be used when the average temperature is within the indicated range.

Take used oil in a sealed container to a local recycling center or service station for reclamation. Do not throw in the trash or pour on the ground.

Oil contains carcinogenic substances. Always wash hands thoroughly after contact with used oil.

1. See Figure 3-1. Clean the area around oil filter cap/dipstick and oil drain bolt.

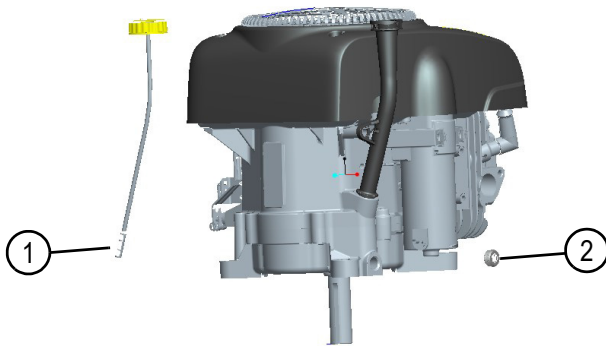

Figure 3-1: Oil Drain Bolt and Dipstick

Item	Description
1	Dipstick
2	Oil Drain Bolt

2. Remove the oil filter cap/dipstick.
3. Remove the oil drain bolt and allow oil to drain into a suitable container.

NOTE

After draining the oil, install oil drain bolt and tighten it securely.

4. Remove and discard the oil filter.
5. Apply a thin film of fresh oil to the oil filter gasket and install **new** oil filter. Hand tighten the filter securely.

6. See Figure 3-2. Fill the engine with 0.8L (27.05 oz.) of recommended oil.

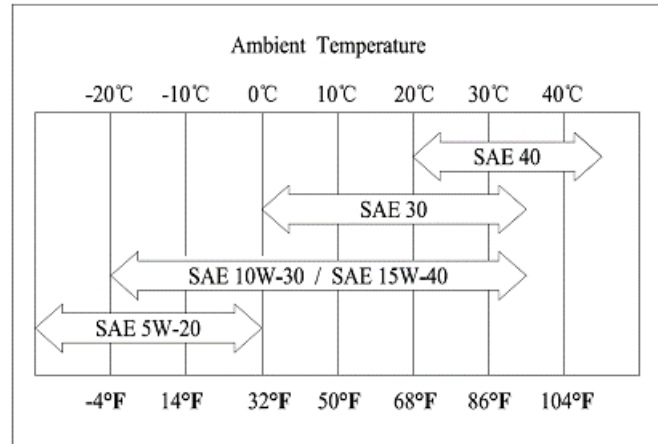

Figure 3-2: Recommended Oil Viscosity

7. Thread the oil filler cap and dipstick into the filler tube.
8. Remove the oil filler cap and dipstick and check the oil level. Bring the level to the upper mark on the dipstick.
9. See Figure 3-3. Run engine, shut it off, and check oil level again. Adjust the oil level as necessary.

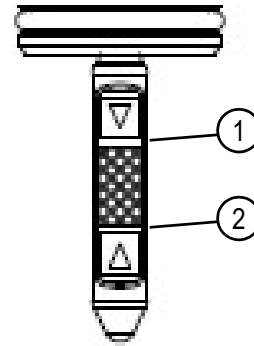

Table 3-1: Dipstick Upper and Lower Oil Level Marks (typical)

Item	Description
1	Upper Mark
2	Lower Mark

Air Filter

NOTICE

Operating the engine without an air filter, or with a damaged air filter will allow dirt to enter the engine, causing rapid engine wear. This type of damage is not covered by warranty.

1. See Figure 3-3. Remove and retain the nuts and remove the air filter cover.
2. Remove the air filter element from the air filter base.
3. Inspect the air filter element for damage. Replace as necessary.

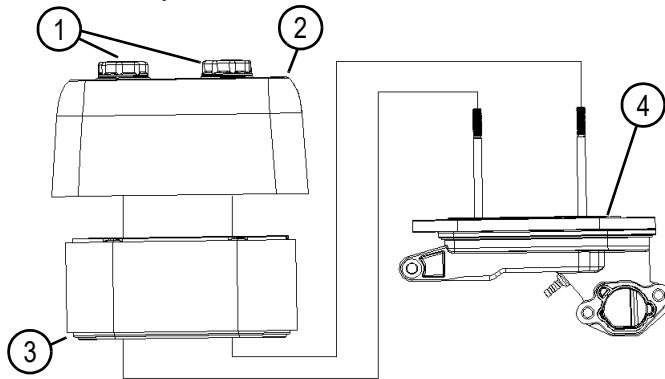

Figure 3-3: Air Filter

Item	Description
1	Nuts
2	Air Filter Cover
3	Air Filter Elements (foam and paper)
4	Air Filter Base

4. Clean the foam air filter element by washing it with warm soapy water and allowing to air dry.

NOTICE

Do not use compressed air or a brush to remove dirt and debris from the paper air filter element as damage to the filter element will result.

5. Inspect the paper filter element. Tap the filter element on a hard surface to dislodge light dirt.
6. Replace the paper air filter element as necessary.

NOTICE

Keep dirt from entering the carburetor during the cleaning process as it can cause rapid engine wear. This type of damage is not covered by warranty.

7. Use a damp cloth to remove dirt from the air filter base and cover.

8. Install the foam air filter element over the paper air filter element and install the element assembly onto the air filter base.
9. Install the air filter cover and secure the cover in place with the nuts removed previously. Tighten securely.

Spark Plug

NOTICE

Use of incorrect spark plugs can result in poor engine performance and engine damage.

Recommended Spark Plug Types

Plug Type	Part Number
NGK	BCPR6ES
Champion	RC12YC

1. Disconnect spark plug boot and remove dirt from the spark plug area.
2. Inspect the spark plug boot for wear or damage and replace as necessary.
3. Use a spark plug wrench and remove the spark plug from the engine.
4. Inspect the spark plug for wear and damage such as; signs of carbon tracking on the electrode, excessively worn electrodes, damage to the porcelain insulator, or excessive deposits.
5. Replace spark plug as necessary.
6. See Figure 3-4. Set the gap to on the spark plug to 0.7-0.8 mm (0.027-0.031 in.).

NOTE

Do not pry on center electrode while setting gap.

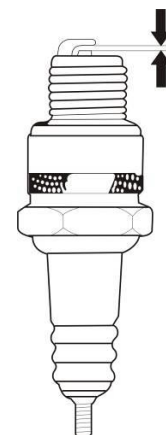

Figure 3-4: Verify Spark Plug Gap

NOTICE

Verify the spark plug is tightened securely. Overtightened and under-tightened spark plugs can result in engine damage.

7. Thread the spark plug in by hand until snug. Then use a spark plug wrench and tighten the spark plug to 18~24 ft-lb (25~32 Nm).
8. Install the spark plug boot on the spark plug.

Valve Clearance

NOTICE

Valve clearance inspection and adjustment must be completed with the engine cold, or poor engine performance and engine damage can result.

1. Remove the valve cover and position the piston at top dead center (TDC) of the compression stroke. Both valves will be completely closed.
2. Verify the exhaust valve is not on the automatic compression release.
3. See Figure 3-5. Use a commercially available feeler gauge and measure the clearance between the rocker arm and the tip of the valve stem.

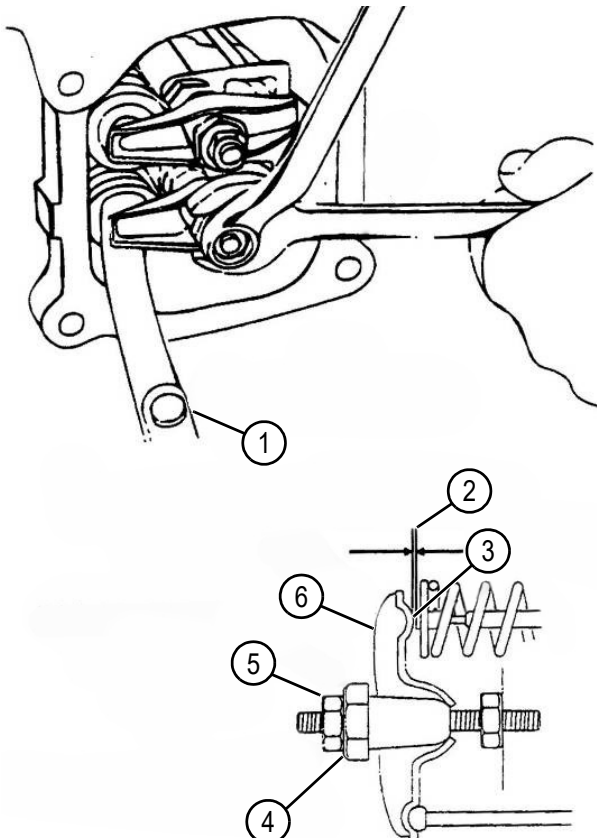

Figure 3-5: Valve Clearance Inspection

Item	Description
1	Feeler Gauge
2	Clearance
3	Valve Stem
4	Pivot Lock Nut
5	Rocker Arm Pivot
6	Rocker Arm

4. Valve clearance should be within the ranges indicated in the table below.

Valve Clearance	
Intake	0.10 ± 0.02 mm (0.004 ± 0.001 in.)
Exhaust	0.15 ± 0.02 mm (0.004± 0.001 in.)

5. If valve clearance adjustment is needed, retain the rocker arm pivot and loosen the pivot lock nut.
6. Turn the rocker arm pivot to obtain the specified clearance.
7. Secure the rocker arm pivot and tighten the pivot lock nut.
8. Verify the proper clearance was obtained. Adjust as necessary.
9. Install the valve cover.

Carburetor and Idle Speed

1. Start the engine and warm to operating temperature.

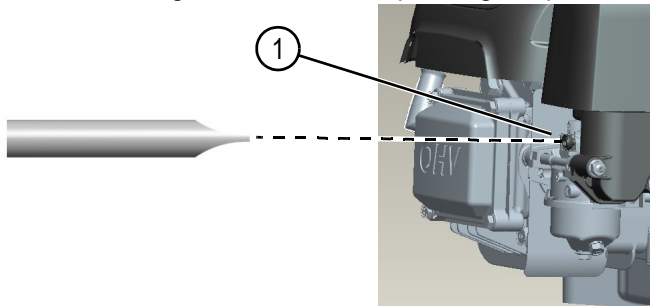

Figure 3-6: Adjust Idle Stop Screw

Item	Description
1	Idle Stop Screw

2. See Figure 3-6. With the engine idling, adjust the throttle stop screw to obtain the recommended engine idle speed of **1850±150 rpm**.

Governor Adjustment

1. See Figure 3-7. Loosen but do not remove the governor arm pinch bolt nut.
2. Move the governor arm rearward to fully open the throttle and hold it in this position.
3. Rotate the governor arm shaft fully clockwise and retain it with a pliers.
4. Tighten the governor arm pinch bolt nut to 8~12 Nm (6~9 ft-lb) to secure the governor arm to the governor arm shaft.
5. Verify the governor arm and throttle valve both move freely.

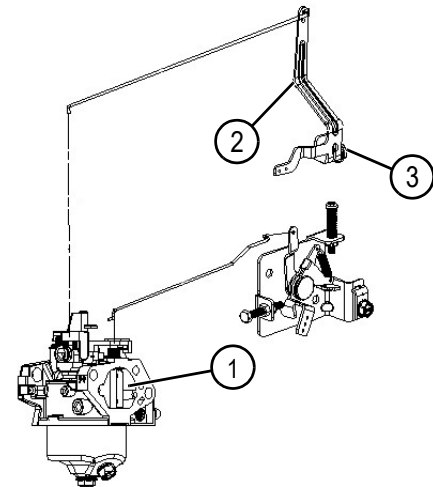

Figure 3-7: Governor Arm

Item	Description
1	Throttle Valve
2	Governor Arm
3	Governor Arm Pinch Bolt and Nut

3

Disassembly and Service

Service Guidelines

1. See Figure 4-1. Use the indicated special tools when required.

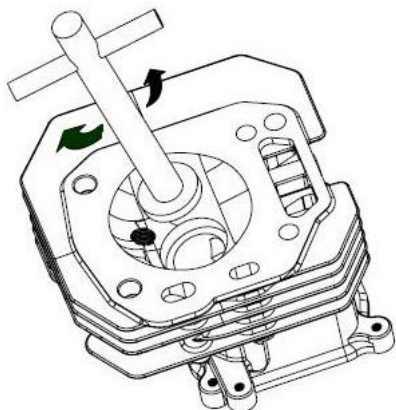

Figure 4-1: Valve Seat Cutting Tool Shown

2. Install **new** gaskets and O-rings during assembly.
3. See Figure 4-2. When installing bolts or nuts, begin with the larger-diameter inner bolt first and tighten to the specified torque in the specified torque sequence.

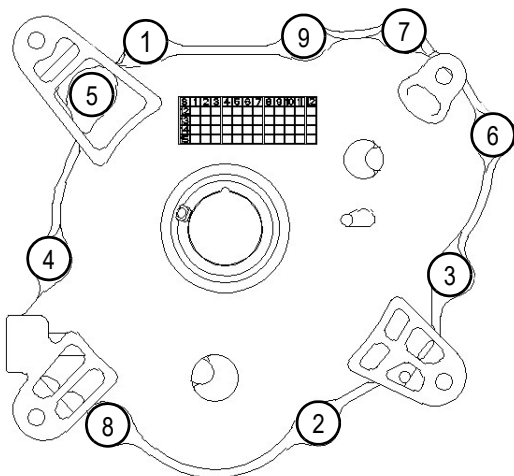

Figure 4-2: Torque Sequence

4. See Figure 4-3. Clean parts thoroughly in a commercially available solvent upon disassembly. Lubricate any sliding surfaces with specified lubricant before assembly.

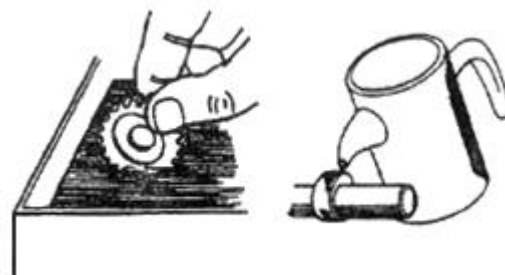

Figure 4-3: Clean and Lubricate Parts

5. After verifying clearances, and prior to assembly, check all parts for damage and wear.

Air Filter Assembly Components

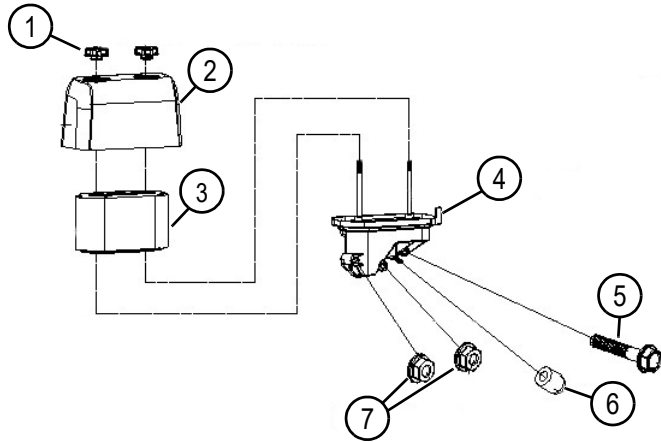

Figure 4-4: Air Filter Assembly

Engine Cover Components

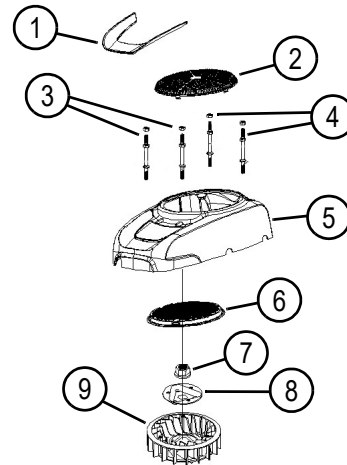

Figure 4-5: Engine Cover Assembly

4

Item	Description
1	Nuts
2	Cover
3	Foam and Paper Elements
4	Air Filter Base
5	Bolt M6x35
6	Plug
7	Nuts (M6)

Item	Description
1	Fan Cover Trim
2	Outer Recoil Cover
3	Stud, M6x65
4	Stud, M6x85
5	External Fan Cover
6	Internal Fan Cover
7	Nut
8	Plate
9	Cooling Fan

Control Lever Components

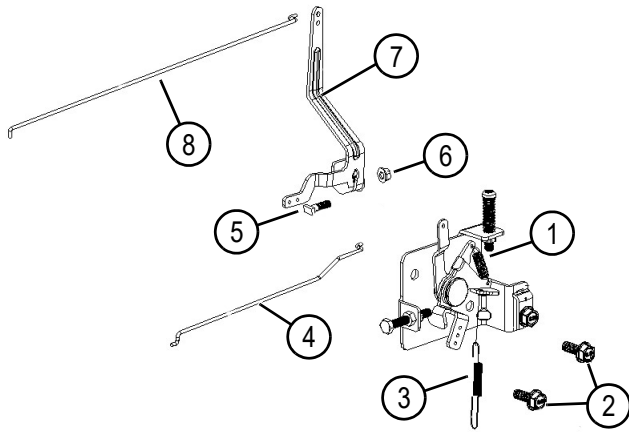

Figure 4-6: Control Lever Assembly

Item	Description
1	Control Assembly
2	Bolt, M6x16
3	Spring
4	Choke Rod
5	Bolt
6	Nut
7	Governor Arm
8	Governor Rod

Carburetor Components

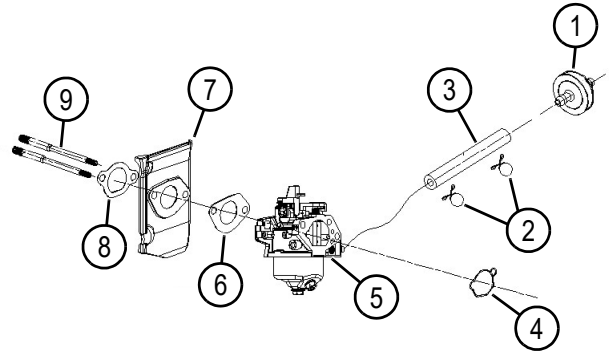

Figure 4-7: Carburetor Assembly

Item	Description
1	Fuel Filter
2	Clamps
3	Fuel Hose
4	Carburetor Gasket
5	Carburetor
6	Carburetor Gasket
7	Shroud
8	Carburetor Gasket
9	Studs

4

Governor

1. See Figure 4-8. Check the gear for damage before installation.
2. Spread the governor flyweights to ease assembly. After installation, verify the assembly moves freely.
3. Insert the pins, pointed end first.

IMPORTANT

Verify the governor moves smoothly after assembly.

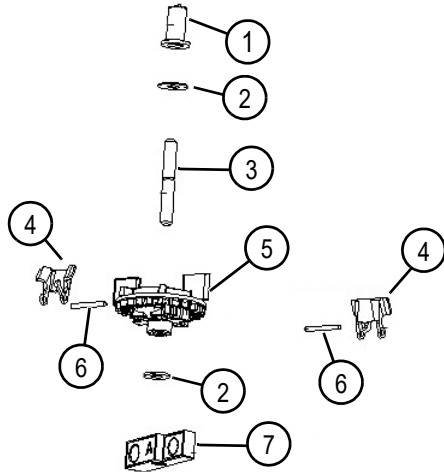

Figure 4-8: Governor Assembly

Item	Description
1	Governor Spool
2	Washer
3	Governor Shaft
4	Governor Flyweight
5	Governor Gear
6	Flyweight Pin
7	Governor Clip

Ignition Coil

See Figure 4-9. Ignition coil gap adjustment is required if the ignition coil or flywheel has been removed from the engine.

When performing a coil gap adjustment, follow the steps below.

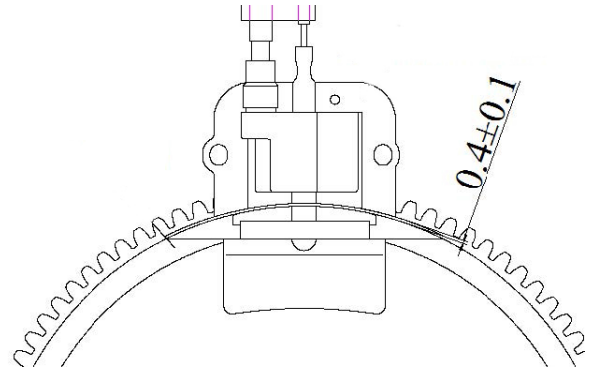

Figure 4-9: Coil Gap Adjustment

NOTICE

Adjust both sides equally to ensure a uniform ignition coil gap.

1. Loosen both of the ignition coil mounting bolts.
2. Pull coil away from the flywheel and tighten one bolt to secure the coil.
3. Rotate the flywheel to the magnet side and align with the coil laminations.
4. Insert a feeler gauge between the coil and magnet and loosen the bolt tightened in step 2. The magnet will pull the coil to set the gap.
5. Tighten the ignition coil mounting bolts to specification.

Ignition Coil Gap to Flywheel

0.4 mm (0.016 in.)

6. Slowly rotate the flywheel and remove the feeler gauge.

4

Inspection

NOTE

Set multimeter to the Ohms setting. Lamination and primary terminal should be lightly etched to obtain a good connection.

1. See Figure 4-10. Place one test lead on the ignition coil primary terminal and one on the coil ground as shown to measure primary coil resistance. Be certain grounding point is clean in order to obtain an accurate reading.

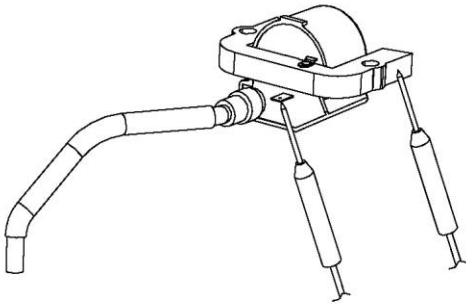

Figure 4-10: Primary Ignition Coil Test

Primary Coil Resistance
1.2Ω

2. See Figure 4-11. Place one meter lead on the spark plug lead, and one on the coil ground as shown. Be certain grounding point is clean in order to obtain an accurate reading

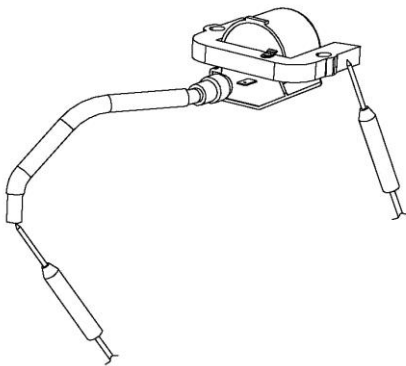

Figure 4-11: Secondary Ignition Coil Test

Secondary Coil Resistance
5.5 KΩ

Flywheel and Fan

4

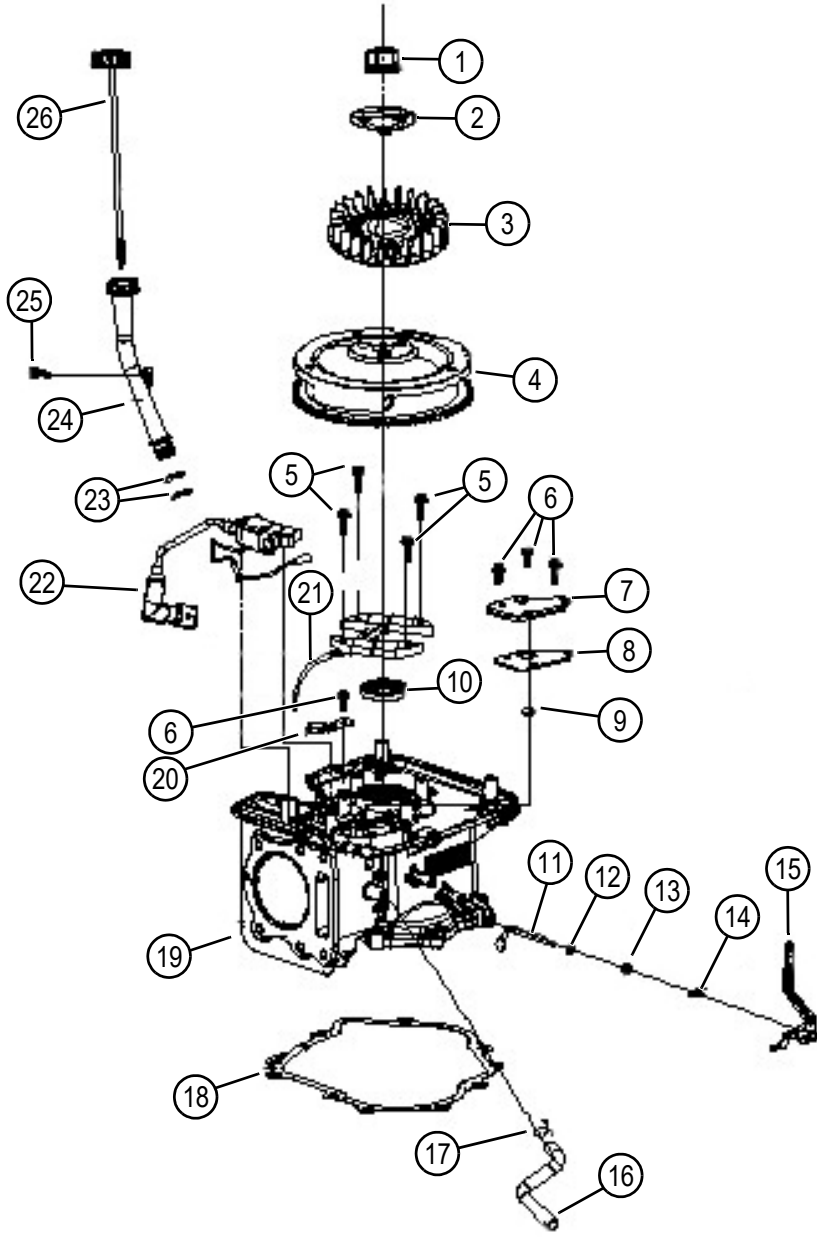

Figure 4-12: Flywheel and Fan Assembly

Item	Description
1	Nut
2	Starter Pulley
3	Cooling Fan
4	Flywheel
5	Bolt, M6x30
6	Bolt, M6x16
7	Breather Chamber Cover
8	Breather Chamber Cover Gasket
9	Breather
10	Oil Seal
11	Governor Arm Shaft
12	Washer
13	Oil Seal
14	Lock Pin
15	Governor Arm
16	Breather Tube
17	Breather Tube Clip
18	Crankcase Cover Gasket
19	Crankcase
20	Plate
21	Charge Coil Assembly
22	Ignition Coil Assembly
23	O-Ring
24	Oil Fill Tube
25	Bolt, M6x20
26	Oil Fill Cap

Cylinder Head and Valves

NOTICE

Loosen and tighten cylinder head bolts in a criss-cross pattern, in two, to three steps.

Before installation, remove carbon deposits from the combustion chamber and inspect the valve seats.

Components should always be measured at room temperature.

Measure the cylinder head compression after assembly.

Removal and Installation

1. See Figure 4-13. Remove engine cover from the engine.
2. Remove the carburetor.
3. Remove muffler.
4. Remove the cylinder head.

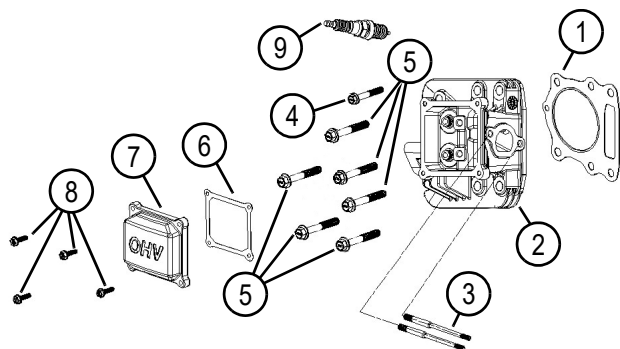

Figure 4-13: Cylinder Head Assembly

Item	Description
1	Cylinder Gasket
2	Cylinder Head
3	Studs
4	Bolt, M8x50
5	Bolt, M10x65
6	Valve Cover Gasket
7	Valve Cover
8	Bolt, M6x25
9	Spark Plug

Disassembly and Assembly

NOTICE

Do not remove valve spring retainers with the cylinder head installed to avoid valves falling.

Check push rods for wear, straightness and proper seating in the valve lifters.

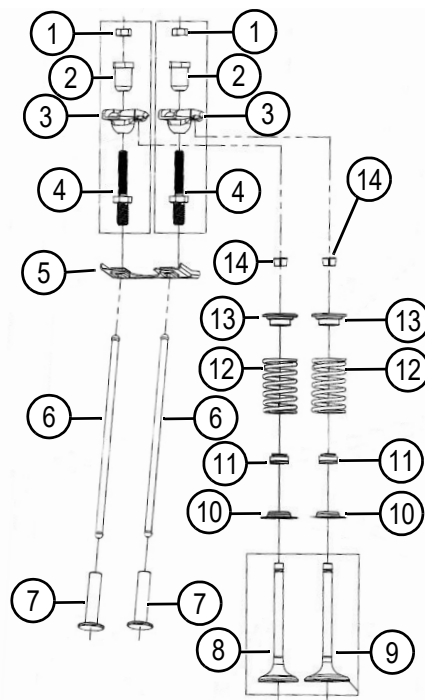

Figure 4-14: Valvetrain Components

Item	Description
1	Pivot Adjusting Nut
2	Rocker Arm Pivot
3	Rocker Arm
4	Rocker Arm Pivot Bolt
5	Push Rod Guide Plate
6	Push Rod
7	Valve Lifter
8	Exhaust Valve
9	Intake Valve
10	Valve Spring Retainer
11	Valve Stem Seal
12	Valve Spring
13	Valve Spring Retainer
14	Valve Spring Retainer Locks

Valve Spring Free Length

1. See Figure 4-15. Use a caliper and measure the valve spring free length

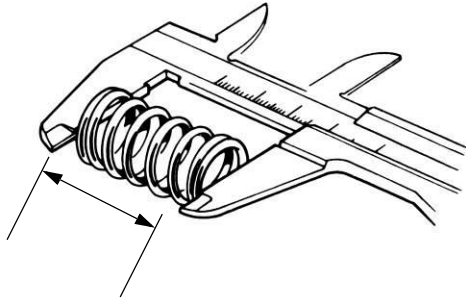

Figure 4-15: Measure Valve Spring Free Length

Standard	Service Limit
39.5~40.5 mm (1.555~1.594 in.)	39.0 mm (1.535 in.)

Valve Seat Width

NOTICE

Remove carbon deposits from the combustion chamber.
 Inspect the valve seats for pitting or other damage.
 Measure valve seat width. If the seat width is under the standard, or over service limit, recondition the valve seat.

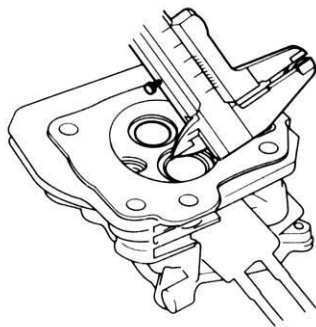

Figure 4-16: Measure Valve Seat Width

Standard	Service Limit
0.8~1.0 mm (0.031~0.039 in.)	1.5 mm (0.059 in.)

Cylinder Head

1. Remove carbon deposits from the combustion chamber. Clean off any gasket material from the cylinder head surface.
2. Check the spark plug hole and valve areas for cracks.
3. See Figure 4-17. Check the cylinder head for warping with a straight edge and a feeler gauge.

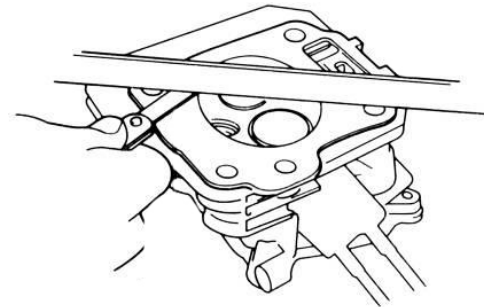

Figure 4-17: Check Cylinder Head for Warping

Service Limit
0.1 mm (0.004 in.)

Valve Stem O.D.

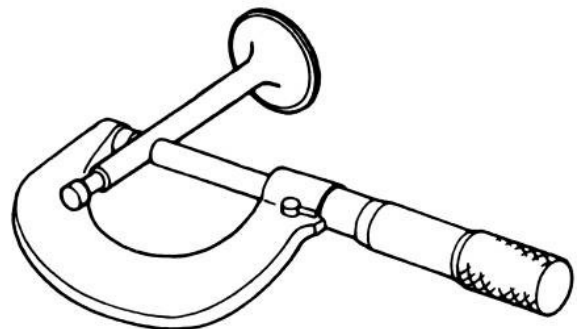

Figure 4-18: Check Valve Stem Diameter

1. Inspect each valve for face irregularities, bending, or abnormal wear.

- See Figure 4-18. Measure and record each valve stem O.D. Replace the valve if O.D. is not within specification.

	Standard	Service Limit
Intake	6.565~6.58 mm (0.2585~0.2591 in.)	6.55 mm (0.2585 in.)
Exhaust	6.545~6.56 mm 0.2576~0.2583 in.)	6.53 mm (0.2571 in.)

Valve Guide I.D.

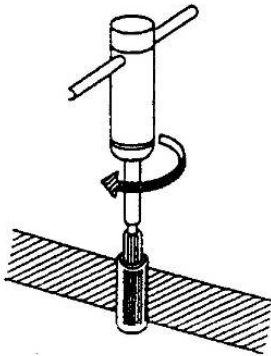

**Figure 4-19: Valve Guide Reamer (typical)
6.6 mm (0.2598 in.) shown**

- See Figure 4-19. Ream the exhaust valve guide to remove the carbon deposits before measuring.
- Measure and record each valve guide I.D.

	Standard	Service Limit
Intake and Exhaust	6.6~6.615 mm (0.2598~0.2604 in.)	6.62 mm (0.2606 in.)

Valve Stem to Valve Guide Clearance

Subtract each valve stem O.D. from the corresponding valve guide I.D. to determine the guide to stem clearance.

NOTICE

If the stem to guide clearance exceeds service limit, determine if the new guide with standard dimensions will bring the clearance within tolerance. If so, replace the guide or cylinder head.

If the stem to guide clearance exceeds service limit with new guides, replace the valves as well. Always recondition the valve seat anytime a valve guide is replaced.

	Standard	Service Limit
Intake	0.02~0.05 mm (0.0008~0.0020 in.)	0.12 mm (0.0047 in.)
Exhaust	0.04~0.07 mm (0.0016~0.0027 in.)	0.17 mm (0.0067 in.)

4

Cylinder Head Service

Exhaust Valve Guide Replacement

NOTICE

The intake valve guide is not replaceable. If the intake valve guide is worn beyond the service limit, replace the cylinder head.

This process simultaneously uses both heated and chilled metals to aid with assembly.

1. Chill the replacement valve guide in a freezer for approximately one-hour.



CAUTION

Wear protective gear to avoid burns when handling the heated cylinder head.



CAUTION

Do not use a torch to heat the cylinder head as damage to the cylinder head can result. Do not heat the head hotter than 150°C (302°F) or damage to the head and valve seats may result.

2. Use a hot plate or oven to heat the cylinder head evenly to 150°C (302°F).
3. Remove the heated cylinder head and support it with wooden blocks.
4. See Figure 4-20. Use a 5.5 mm (0.2165 in.) valve guide driver and carefully remove the exhaust valve guide from the cylinder head.

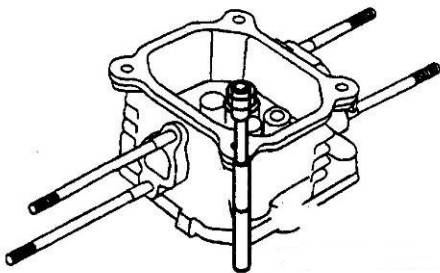

Figure 4-20: Valve Guide Driver Shown
5.5 mm (0.2165 in.)

5. Remove the **new** exhaust valve guide from the freezer.

6. See Figure 4-21. Use the valve guide driver and install the **new** valve guide from the valve spring side of the cylinder head until the clip is fully seated as shown.

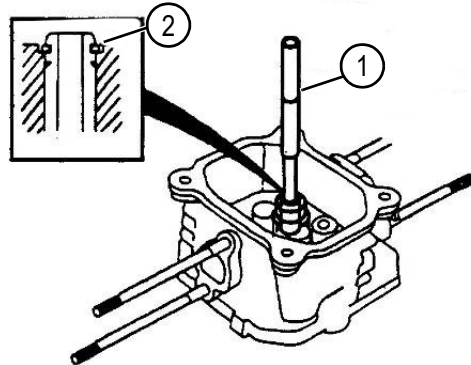

Figure 4-21: Exhaust Guide Fully Installed
(clip fully seated)

7. After installation, inspect the installed **new** valve guide for damage. Replace if damaged during installation process.

Exhaust Valve Guide Reaming

NOTE

Verify the cylinder head is room temperature before reaming the exhaust valve guide.

1. Apply cutting oil to the reamer and the valve guide.
2. See Figure 4-22. Rotate the reamer clockwise through the valve guide for the full length of the reamer.

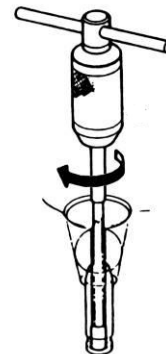

Figure 4-22: Valve Guide Reamer 6.6 mm (0.2598 in.)

3. Continue to rotate the reamer clockwise while removing it from the valve guide.
4. Thoroughly clean the cylinder head to remove residuals from the reaming process.

- See Figure 4-23. Verify the valve guide bore is straight, round, and centered in the guide.

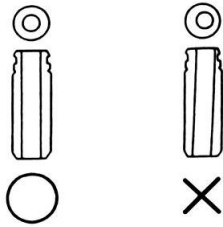

Figure 4-23: Valve Guide, Good (left) Bad (right)

- Insert the valve and check operation. If the valve does not operate smoothly, the guide may have bent during installation. Replace the valve guide if damaged.
- Verify the valve stem to guide clearance.

Valve Seat Reconditioning

- Thoroughly clean the combustion chambers and valve seats to remove carbon deposits.
- Apply a light coat of Prussian Blue or erasable felt tip marker to the valve faces.
- Insert the valve and close it firmly against the seat several times. Verify the valve does not rotate on the seat during this process. The transferred marking will show any area of the seat that is not concentric.

IMPORTANT

Always turn the cutter clockwise, never counterclockwise. Continue to turn the cutter as it is lifted from the valve seat.

- Use a 45° cutter and remove enough material to produce a smooth and concentric seat. Refer to the valve cutter instructions for more information.
- Use a 30–32° and 60° cutter to narrow and adjust the valve seat to contact the middle of the valve face. The 30–32° cutter removes material from the top edge and the 60° cutter removes material from the bottom edge.
- See Figure 4-24. Verify the width of the finished seat is within specification.

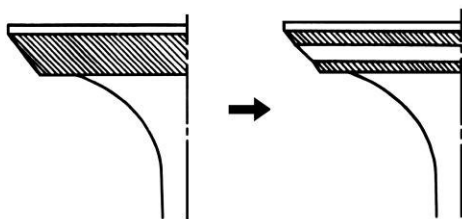

Figure 4-24: Valve Face Marking Examples

Valve Seat Width

- Make a light pass with a 45° cutter to remove any possible burrs at the edges of the seat.
- After resurfacing the seats, verify the valve seating is even.
- Apply a light coat of Prussian Blue or erasable felt tip marker ink to the valve faces.
- Insert the valve and close it firmly against the seat several times.
- Verify the valve does not rotate on the seat during this process. The transferred marking compound will show any area of the seat that is not concentric and should have good contact all the way around.
- See Figure 4-25. for valve seat width examples.

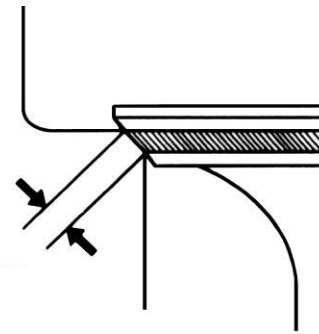

Figure 4-25: Valve Face Measurement

Standard	Service Limit
0.8~1.0 mm (0.03~0.039 in.)	1.5 mm (0.059 in.)

Valve Lapping

1. Verify all surfaces are clean.
2. Place a small amount of clean engine oil on the valve stem.
3. Please a small amount of valve lapping compound on the face of the valve.
4. Install the valve in the cylinder head.
5. See Figure 4-26. Attach the valve lapping tool suction cup end to the valve.

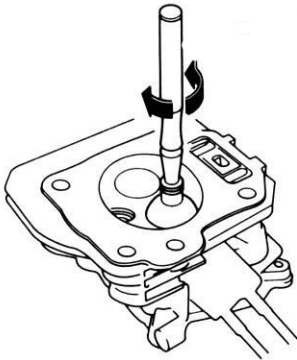

Figure 4-26: Valve Lapping Tool (typical)

6. Rotate lapping tool with hands, 180° in each direction to pivot the valve on the seat, periodically lifting up on the tool to monitor progress.
7. Verify the ring on the valve face is consistent all the way around the valve.
8. When the lapping process is completed, be sure to completely clean all residual lapping compound off the valve seat, valve, and cylinder head.

Crankshaft, Piston and Camshaft

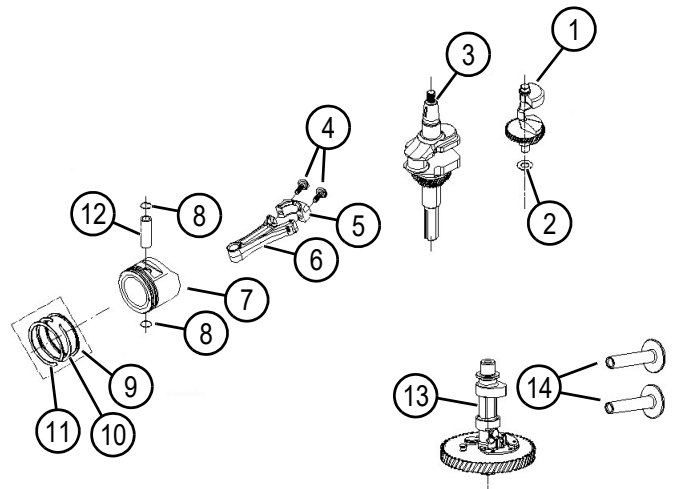

Figure 4-27: Crankshaft, Piston and Camshaft Assembly

Item	Description
1	Counter Balancer
2	Washer
3	Crankshaft
4	Connecting Rod Bolts
5	Connecting Rod Cap
6	Connecting Rod
7	Piston
8	Piston Pin Clip
9	Oil Ring
10	Second Ring
11	Top Ring
12	Piston Pin
13	Camshaft
14	Camshaft Lifters

Disassembly

IMPORTANT

Make note all timing marks, piston markings and be sure to clearly label all parts prior to disassembly. If timing gear is damaged on the crankshaft, replace the crankshaft.

1. Remove the crankcase cover from the engine.
2. Remove the piston and connecting rod assembly from the engine.
3. Remove lifters.
4. Remove crankshaft, camshaft, counter balancers, and counter balancer washers from the cylinder block.
5. Inspect all parts for wear and damage. Replace as necessary.
6. Remove seals and gaskets from cylinder block.
7. Clean and inspect cylinder block.

Crankcase Cover

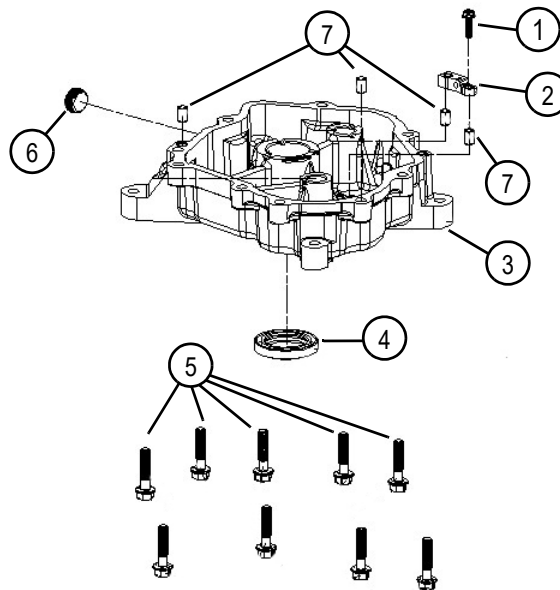

Figure 4-28: Crankcase Cover

4 Assembly

IMPORTANT

Lubricate all ring, bearing, and other friction surfaces with clean engine oil. Use caution not to damage rubber seals during assembly.

Pay close attention to timing marks of crankshaft, camshaft, and counter balancers during assembly.

1. Install **new** seals into cylinder block.
2. Install crankshaft, lifters, camshaft, counter balancer washers and counter balancers into the cylinder block.
3. Install the piston and connecting rod assembly.
4. Tighten all fasteners to specification.
5. Verify engine turns freely after assembly.

Item	Description
1	Bolt M6x25
2	Governor Plate
3	Crankcase Cover
4	Oil Seal
5	Bolt, M10x35
6	Drain Bolt
7	Alignment Pin

Piston, Rings, and Connecting Rod

Disassembly

IMPORTANT

Note the position of the piston on the connecting rod prior to disassembly.

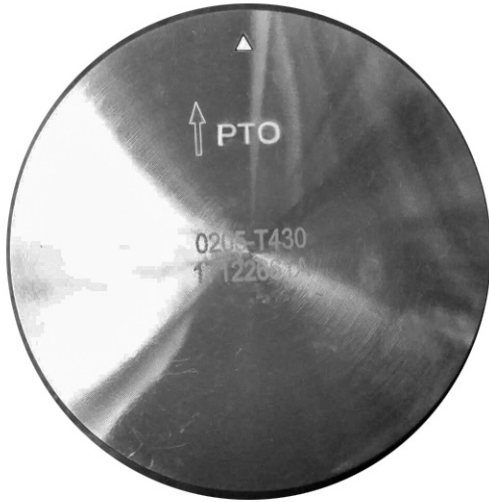

Figure 4-29: Piston Directional Markings (typical)

1. See Figure 4-30. If replacing the piston rings, remove piston rings from piston and discard.

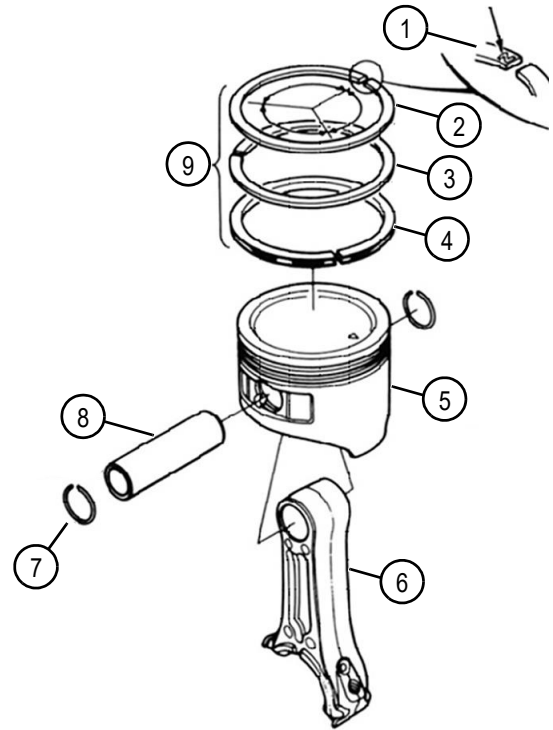

Figure 4-30: Piston Rings and Connecting Rod (typical)

Item	Description
1	Piston Ring Marking
2	Top Ring
3	Second Ring
4	Oil Ring
5	Piston
6	Connecting Rod
7	Piston Pin Clip
8	Piston Pin
9	Piston Ring Positioning

2. If replacing the piston, remove piston pin clips and remove the piston pin from the piston.
3. Verify connecting rod condition and specifications.

Assembly

1. With the piston positioned correctly, install piston to connecting rod.

IMPORTANT

Install one piston pin clip into one side of the piston before installing the piston pin.

Position the clip opening away from the slot in the piston.

2. Apply clean engine oil to the piston pin and insert to retain piston.
3. Install the other piston pin clip and verify both are seated.
4. Verify piston moves freely on the connecting rod and rings move freely on the piston after assembly.
5. Install piston rings and position as shown.

4 Cylinder Bore Measurement

Measuring Cylinder Bore Taper

1. Set the micrometer to standard cylinder bore diameter, or approximate oversize.
2. Zero the dial bore gauge to cylinder bore diameter on the micrometer.
3. See Figure 4-31. Measure the top, middle and bottom of the cylinder bore at the X and Y axis.

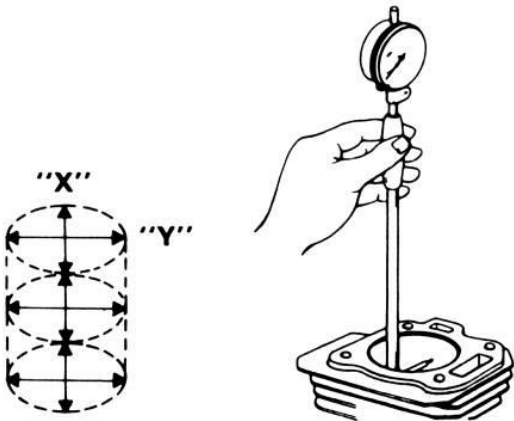

Figure 4-31: Checking Cylinder Taper (typical)

4. Subtract the smallest number from the largest number for taper measurement results.

Cylinder Bore Service Wear Limit

1. Set the micrometer to service wear limit.
2. Zero the dial bore gauge to service wear limit on the micrometer.
3. See Figure 4-32. Measure the top, middle and bottom of the cylinder bore at the X and Y axis.

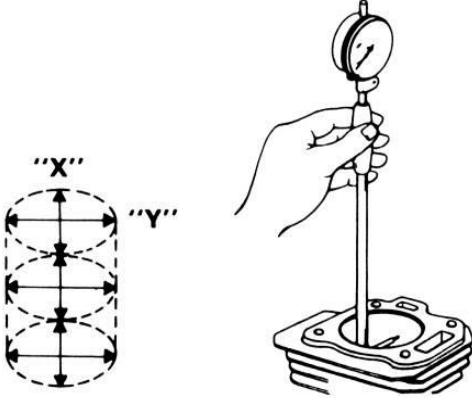

Figure 4-32: Checking Cylinder Bore Service Limit

Standard for X and Y Axis	Service Limit for X and Y Axis
85~85.01 mm (3.346~3.347 in.)	85.1 mm (3.35 in.)

NOTE

All measurements should be negative, and none greater than zero on the dial bore gauge.

IMPORTANT

Measurements of ZERO on the dial bore gauge indicate the cylinder is below the service wear limit.

Measurements of NEGATIVE numbers indicate the cylinder is below the service wear limit.

Measurements of POSITIVE numbers indicate the cylinder is larger than the service wear limit and must be oversized.

Piston Skirt Outside Diameter

1. See Figure 4-33. Measure the piston skirt outside diameter at 10 mm from the bottom of the piston skirt as shown, 90° from the piston pin.

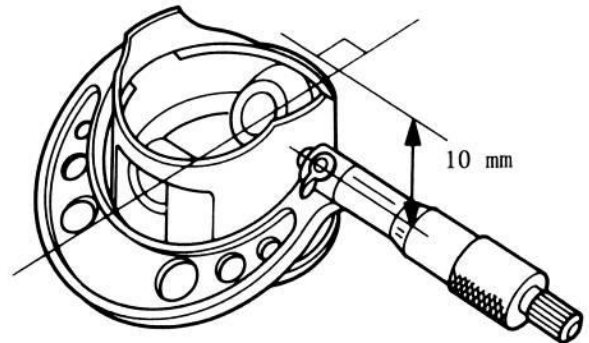

Figure 4-33: Piston Skirt Measurement

2. Verify the measurements are within specification.

Standard	Service Limit
84.965~84.975 mm (3.3450~3.3455 in.)	84.94 mm (3.344 in.)

Piston to Cylinder Clearance

Standard	Service Limit
0.025~0.045 mm (0.0010~0.0018 in.)	0.081 mm (0.0032 in.)

Piston Pin

1. See Figure 4-34. Inspect piston pin for damage and measure piston pin.

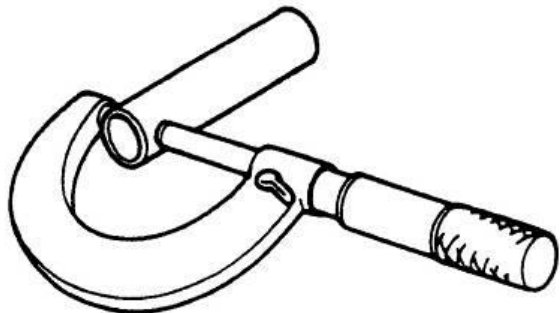

Figure 4-34: Measure Piston Pin

2. Verify piston pin is within specification.

4

Standard	Service Limit
19.992~19.998 mm (0.787~0.7873 in.)	19.9 mm (0.7834 in.)

Piston Ring End Gap

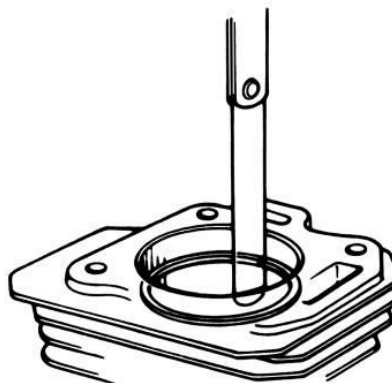

Figure 4-36: Piston Ring End Gap Measurement (typical)

Standard	Service Limit
0.2~0.35 mm (0.0079~0.0138 in.)	0.4 mm (0.016 in.)

Piston Ring Width

1. See Figure 4-35. Measure top and second piston ring width.

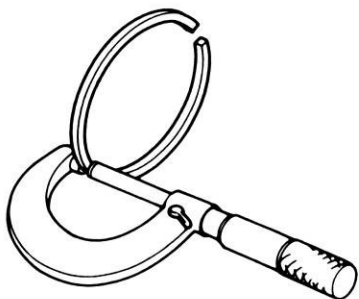

Figure 4-35: Measure Piston Ring Width

2. Verify rings are within specification

Standard	Service Limit
Top and Second 1.17~1.19 mm (0.046~0.047 in.)	1.1 mm (0.043 in.)
Oil Ring 1.88~1.95 (0.074~0.788 in.)	1.7 mm (0.067 in.)

Piston Ring Side Clearance

1. See Figure 4-37. Measure piston ring side clearance.

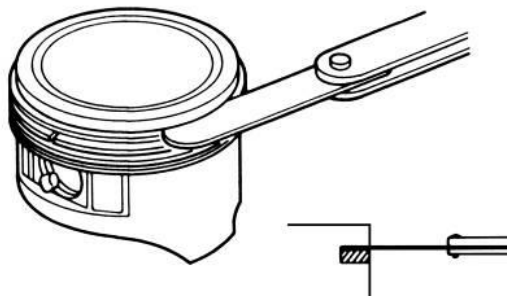

Figure 4-37: Measure Side Clearance

2. Verify the ring side clearance is within specification.

Standard	Service Limit
Top and Second 0.02~0.06 mm (0.0008~0.0024 in.)	0.11 mm (0.0043 in.)

Connecting Rod Small End I.D.

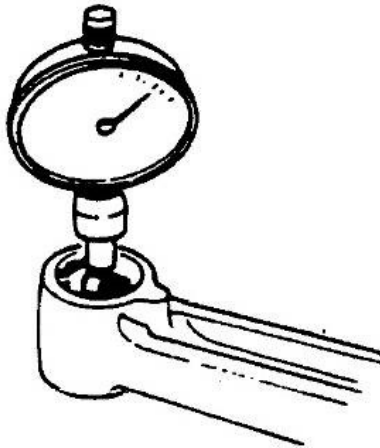

Figure 4-38: Measure Connecting Rod Small End

Standard	Service Limit
20.006~20.017 mm (0.787~0.788 in.)	20.02 mm (0.7882 in.)

Crankshaft Rod Journal O.D.

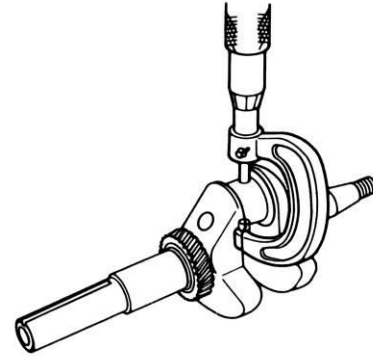

Figure 4-40: Crankshaft Rod Journal Measurement

Standard	Service Limit
34.966~34.981 mm (1.376~1.377 in.)	34.946 mm (1.375 in.)

Connecting Rod Big End Side Clearance

Connecting Rod Big End I.D.

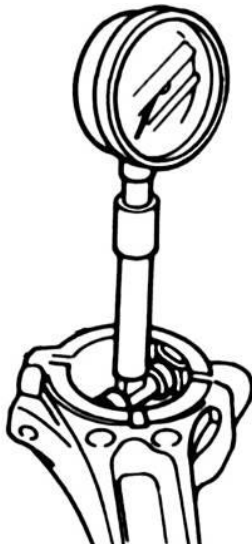

Figure 4-39: Measure Connecting Rod Big End

Standard	Service Limit
36.02~36.04 mm (1.4181~1.4189 in.)	36.05 mm (1.4193 in.)

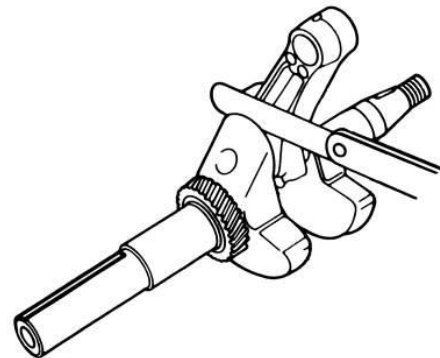

Figure 4-41: Connecting Rod Big End Side Clearance Measurement

Standard	Service Limit
0.03~0.35 mm (0.0012~0.0138)	0.4 mm (0.016 in.)

4

Connecting Rod Big End Oil Clearance (Radial)

1. Clean all oil from the crankshaft and journal and connecting rod surface.

IMPORTANT

Do not rotate the crankshaft during the measurement process.

2. See Figure 4-42. Place a piece of Plastigauge® on the crankshaft rod journal, assemble the connecting rod and tighten the bolts to 8~10 ft-lb (11.5~13.5 Nm).

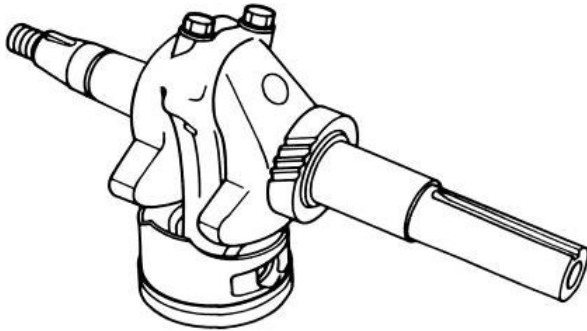

Figure 4-42: Measure Connecting Rod Oil Clearance

3. See Figure 4-43. Remove connecting rod cap and measure the Plastigauge® to verify the oil clearance is within specification.

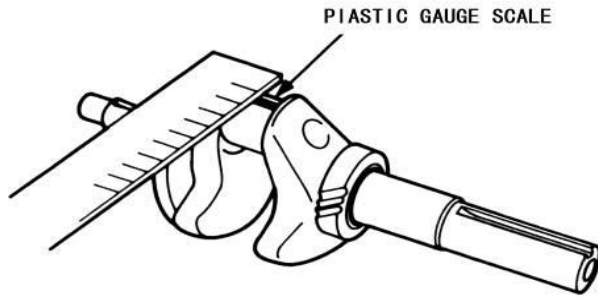

Figure 4-43: Remove Cap and Measure

Standard	Service Limit
0.040~0.063 mm (0.00157~0.00248 in.)	0.083 mm (0.003267 in.)

4. If measured clearance exceeds service limit, replace the crankshaft and connecting rod.

NOTE

After using new connecting rod, if clearance still exceeds the service limit, machine crankshaft and use a connecting rod lower than standard value.

Camshaft Cam Lobe Height

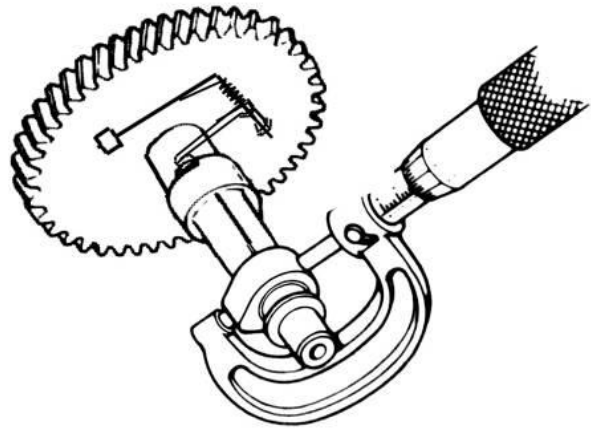

Figure 4-44: Measure Camshaft Lobes

Standard	Service Limit
Intake 32.535~32.635mm (1.281~1.285 in.)	32.4 mm (1.276 in.)
Exhaust 32.018~32.118 mm (1.261~1.264 in.)	31.9 mm (1.256 in.)

Camshaft Journal Diameter

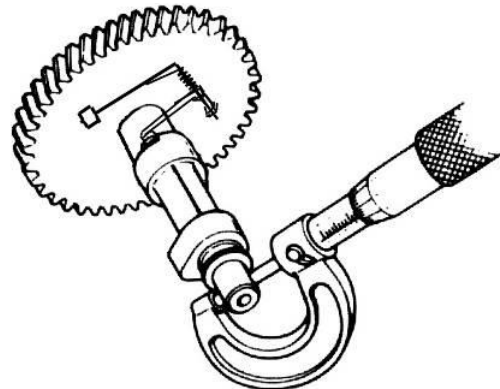

Figure 4-45: Measure Camshaft Journal

Standard	Service Limit
15.966~15.984 mm (0.628~0.629 in.)	15.916 mm (0.626 in.)

NOTE

Note the location of the decompression mechanism, and verify it moves freely.

4

Troubleshooting

Hard to Start

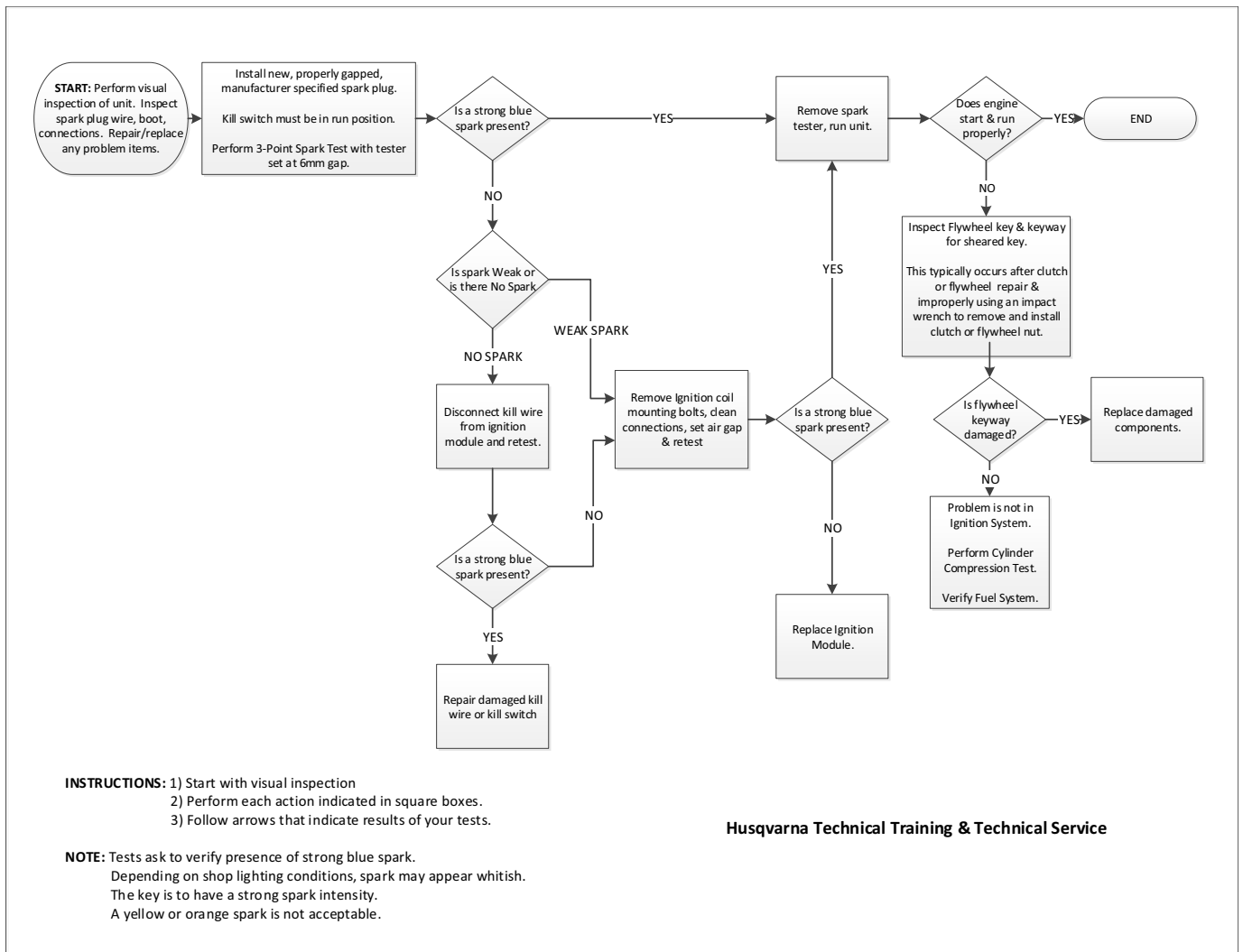

Overheating

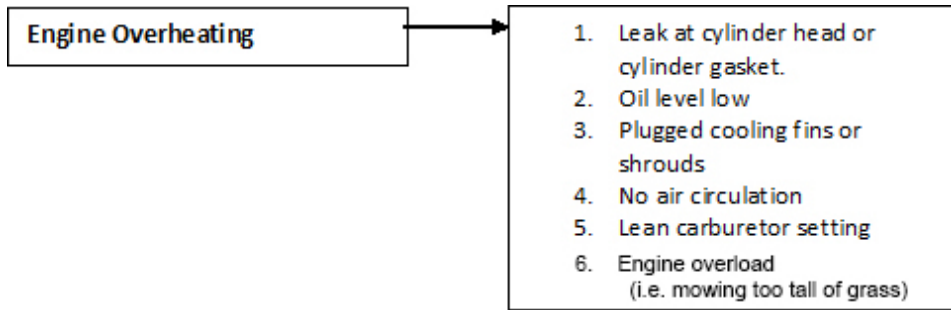

Poor Engine Performance

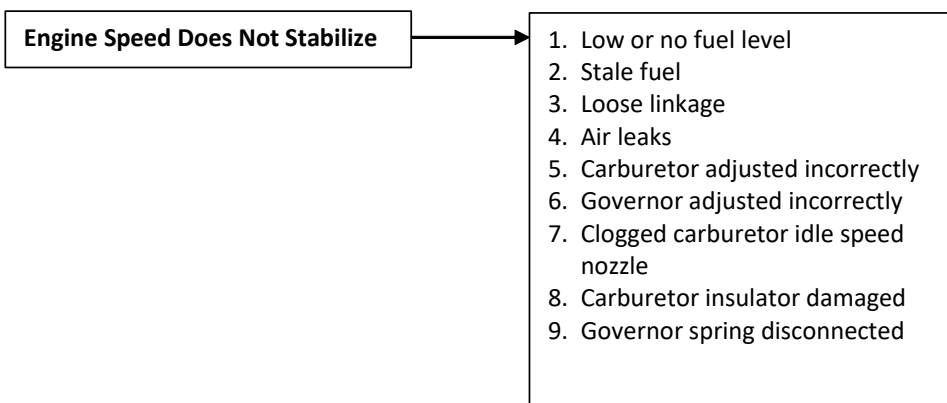
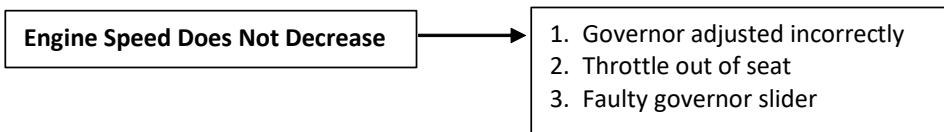
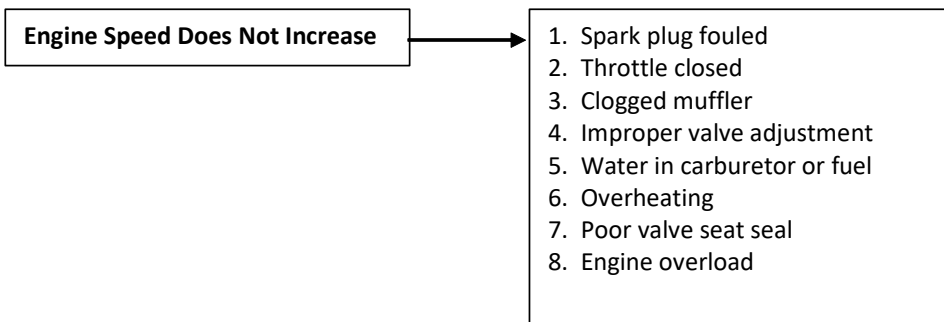
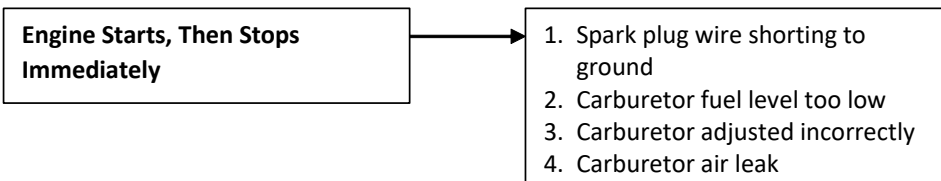

5

Starter Motor Troubleshooting Guide

WARNING

Personal Injury. Engine may be cranked in this test. Keep appendages and clothing away from rotating parts of engine. Failure to do so could result in serious injury.

CAUTION

Unit Damage. If starter does not stop when engine switch is turned to OFF, disconnect negative (-) lead from battery as soon as possible. Failure to do so could damage the unit.

1. Disconnect spark plug boots from spark plugs.
2. Ground spark plug wires or disable ignition to prevent damage to the ignition module.
3. Turn engine switch to START and verify starter motor activation.

1. Starter Does Not Activate

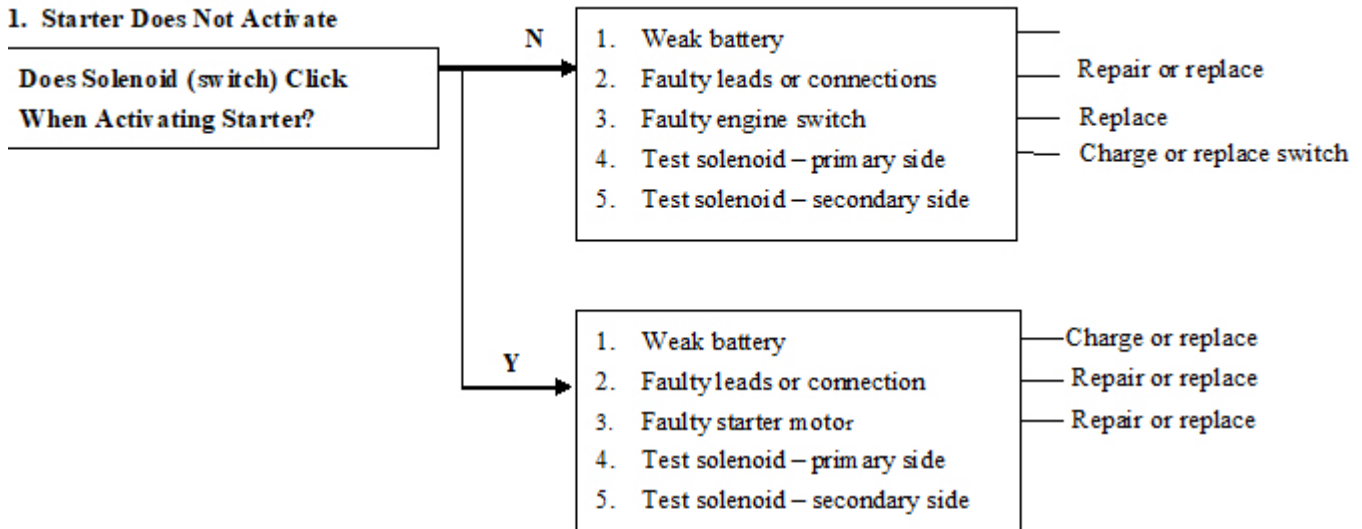

2. Starter Rotates Slowly

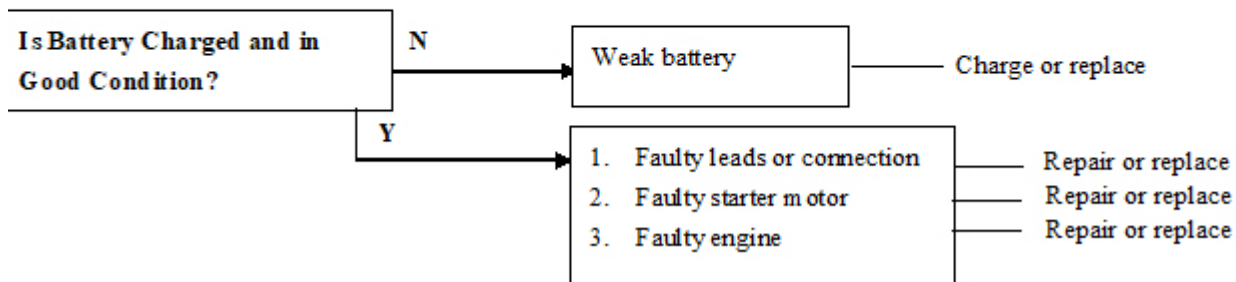

Check for Spark



WARNING

Electric Shock. Do not touch spark plug wire or electrode when cranking engine. Doing so could result in electric shock.

1. Remove and inspect spark plug condition and gap.
2. Check for spark using a commercially available spark plug tester, or a known good plug.
3. If spark plug does not pass test, replace spark plug.
4. Check coil and switch.

Check Cylinder Compression

1. Clean debris from the spark plug area.
2. Verify battery is good (if equipped).
3. Remove spark plug boot and spark plug.
4. Ground the plug wire or disable the ignition.
5. Install commercially available compression gauge.

IMPORTANT

To obtain correct compression reading, engine speed must be above 1,000 rpm to ensure the decompression valve allows for cylinder compression.

Do no over crank starter. Give periodic breaks to allow starter to cool.

6. Crank engine until compression gauge reaches full reading. Verify compression is within specification.

Standard	Service Limit
8.7 kg/cm ² * (123.7 psi)	8.0kg/cm ² (113 psi)