

# **ILLUSTRATED PARTS LIST**

**MFG. ID NO. 96051015200**

**CUST. CAT. NO. M185-107TC POWERDRIVE**

**PRODUCT NO. 960 51 01-52**

**TRACTOR - MODEL NO. M185-107TC (96051015200), PROD. NO. 960 51 01-52**  
**DECALS 27**

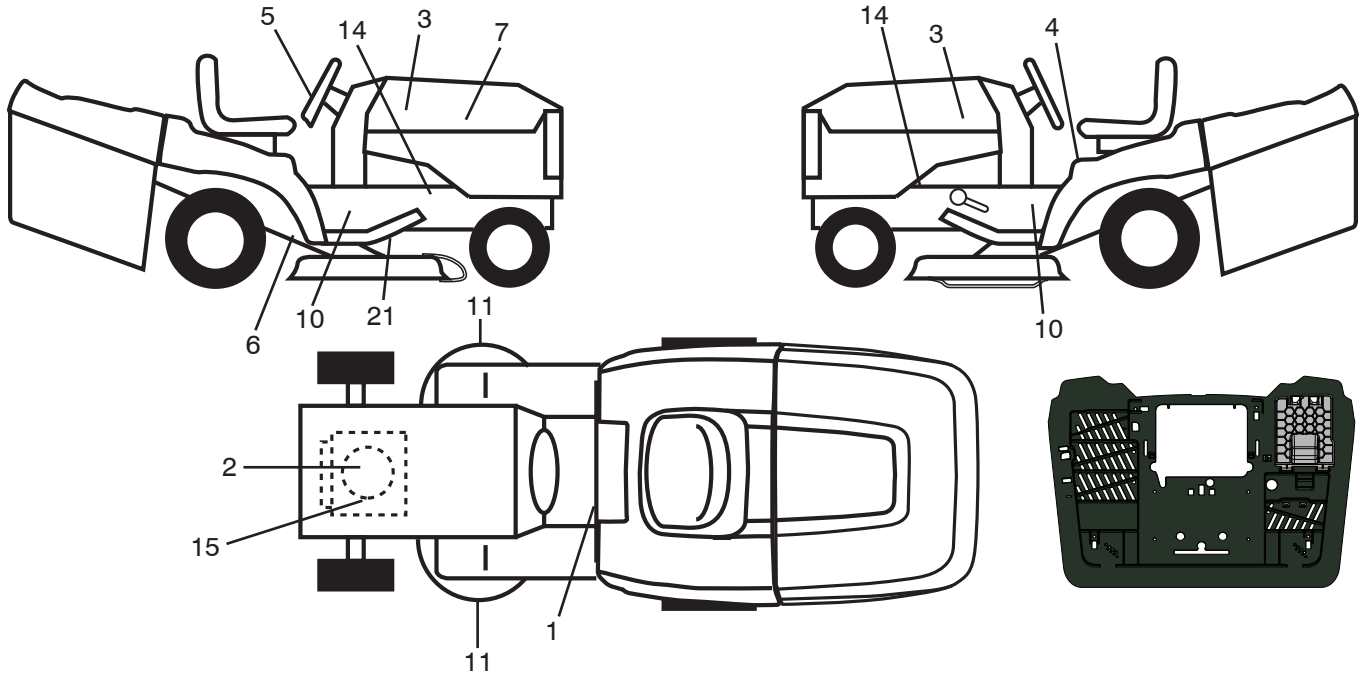

KEY NO.	PART NO.	DESCRIPTION
1	581 57 83-01	Decal, Warning
2	581 57 97-01	Decal, Warning Eng. Sym.
3	581 09 12-01	Decal, Hood RH/LH
4	581 92 55-01	Decal, SD Fender
5	501 49 43-01	Decal, Steering Wheel
6	583 90 19-01	Decal, Underfender
7	582 87 95-01	Decal, Replacement
10	581 57 98-01	Decal, Warning
11	581 57 91-01	Decal, Mower Cut Finger Symbol

KEY NO.	PART NO.	DESCRIPTION
14	581 57 96-01	Decal, Chassis Hot Muffler
15	532 43 74-20	Decal, Engine HP
21	532 44 11-89	Decal, Belt Sch CRD
--	532 42 59-86	Pad Footrest RH
--	532 42 59-76	Pad Footrest LH
--	115 84 33-20	Manual Operator's (EURO)
--	115 84 34-10	Manual Operator's (SCAN)
--	115 84 35-50	Manual Operator's (EBLOC)
--	115 84 36-40	Manual Operator's (BALTIC)

**WHEELS & TIRES**

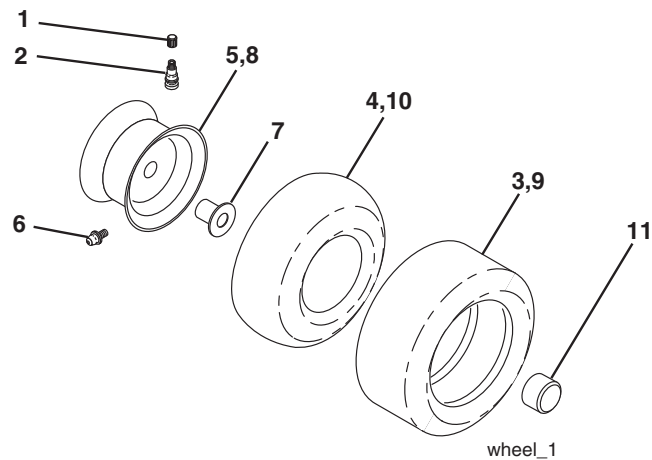

KEY NO.	PART NO.	DESCRIPTION
1	532 05 91-92	Cap Valve Tire
2	532 06 51-39	Stem Valve
3	532 10 62-22	Tire Front 15 x 6-6
4	532 05 99-04	Tube Inner Front #35060
5	532 12 51-21	Rim Asm 6" Front Silver Service
6	532 12 49-57	Fitting Grease
7	532 12 49-59	Bearing Flange
8	532 12 51-22	Rim Asm 8" Rear Silver Service
9	532 42 05-31	Tire Rear 18 x 9.5-8
10	532 12 49-26	Tube Rear 9 5 x 8 Service
11	532 19 32-68	Cap Axle Blk 1 50 x 1 00
--	532 14 43-34	Sealant, Tire (10 oz. Tube)

**NOTE:** All component dimensions given in U.S. inches  
 1 inch = 25.4 mm

# TRACTOR - MODEL NO. M185-107TC (96051015200), PROD. NO. 960 51 01-52

## SCHEMATIC 38

SCH17

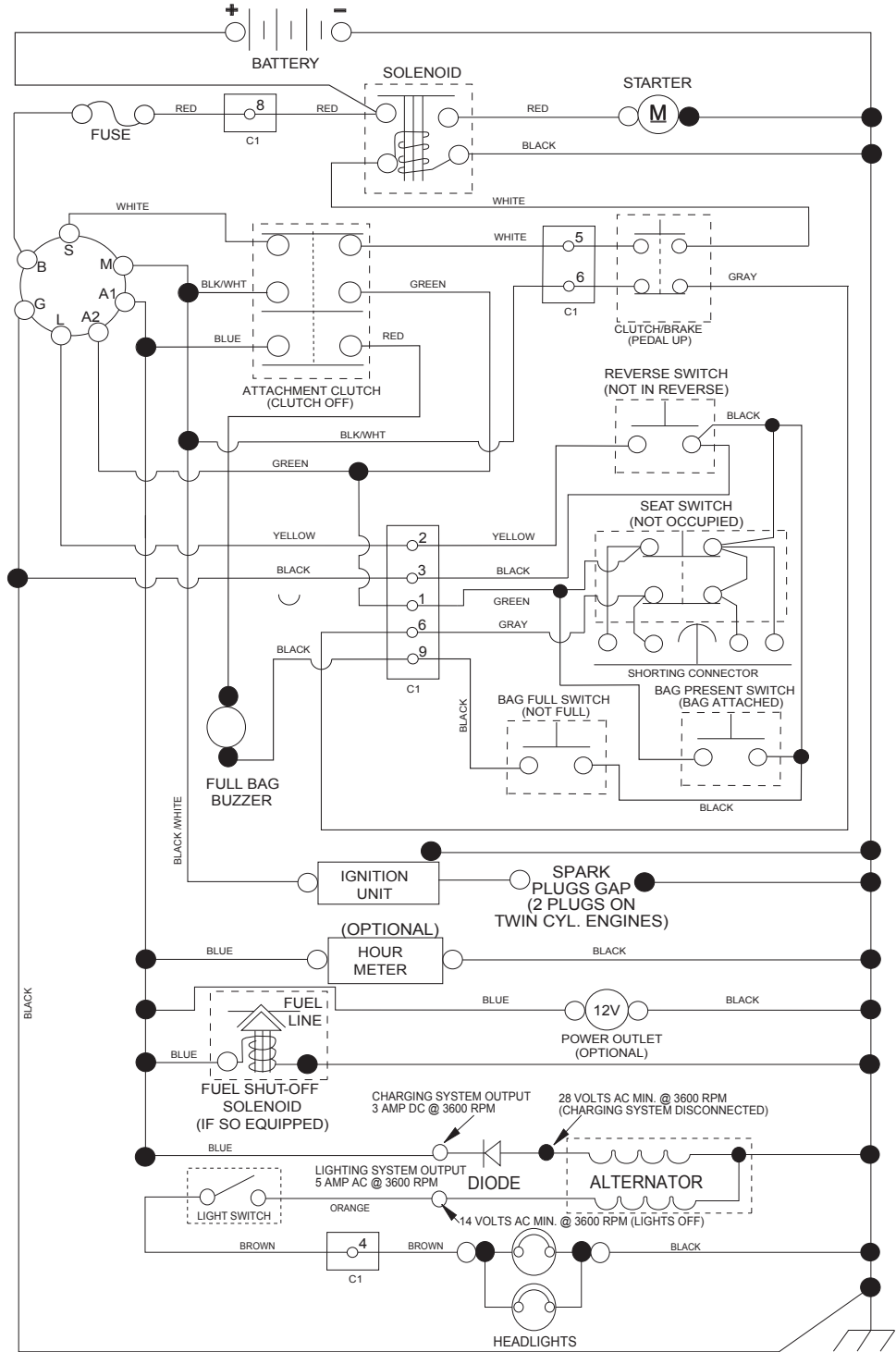

**NOTE**  
YOUR TRACTOR IS EQUIPPED WITH A SPECIAL ALTERNATOR SYSTEM. THE LIGHTS ARE NOT CONNECTED TO THE BATTERY, BUT HAVE THEIR OWN ELECTRICAL SOURCE. BECAUSE OF THIS, THE BRIGHTNESS OF THE LIGHTS WILL CHANGE WITH ENGINE SPEED. AT IDLE THE LIGHTS WILL DIM. AS THE ENGINE SPEED IS INCREASED, THE LIGHTS WILL BECOME THEIR BRIGHTEST.

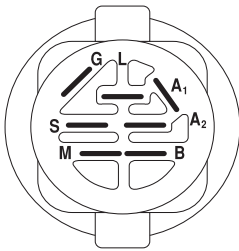

IGNITION SWITCH

POSITION	CIRCUIT	"MAKE"
OFF	M+G+A1	
RUN/OVERRIDE	B+A1	
RUN	B+A1	L+A2
START	B + S + A1	

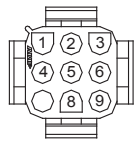

CHASSIS HARNESS CONNECTOR (C1) (MATING SIDE)

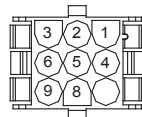

DASH HARNESS CONNECTOR (C1) (MATING SIDE)

WIRING INSULATED CLIPS  
NOTE: IF WIRING INSULATED CLIPS WERE REMOVED FOR SERVICING OF UNIT, THEY SHOULD BE RE-INSTALLED TO PROPERLY SECURE YOUR WIRING.

NON-REMOVABLE CONNECTIONS

REMOVABLE CONNECTIONS

**TRACTOR - MODEL NO. M185-107TC (96051015200), PROD. NO. 960 51 01-52**  
**ELECTRICAL 32**

TC03S

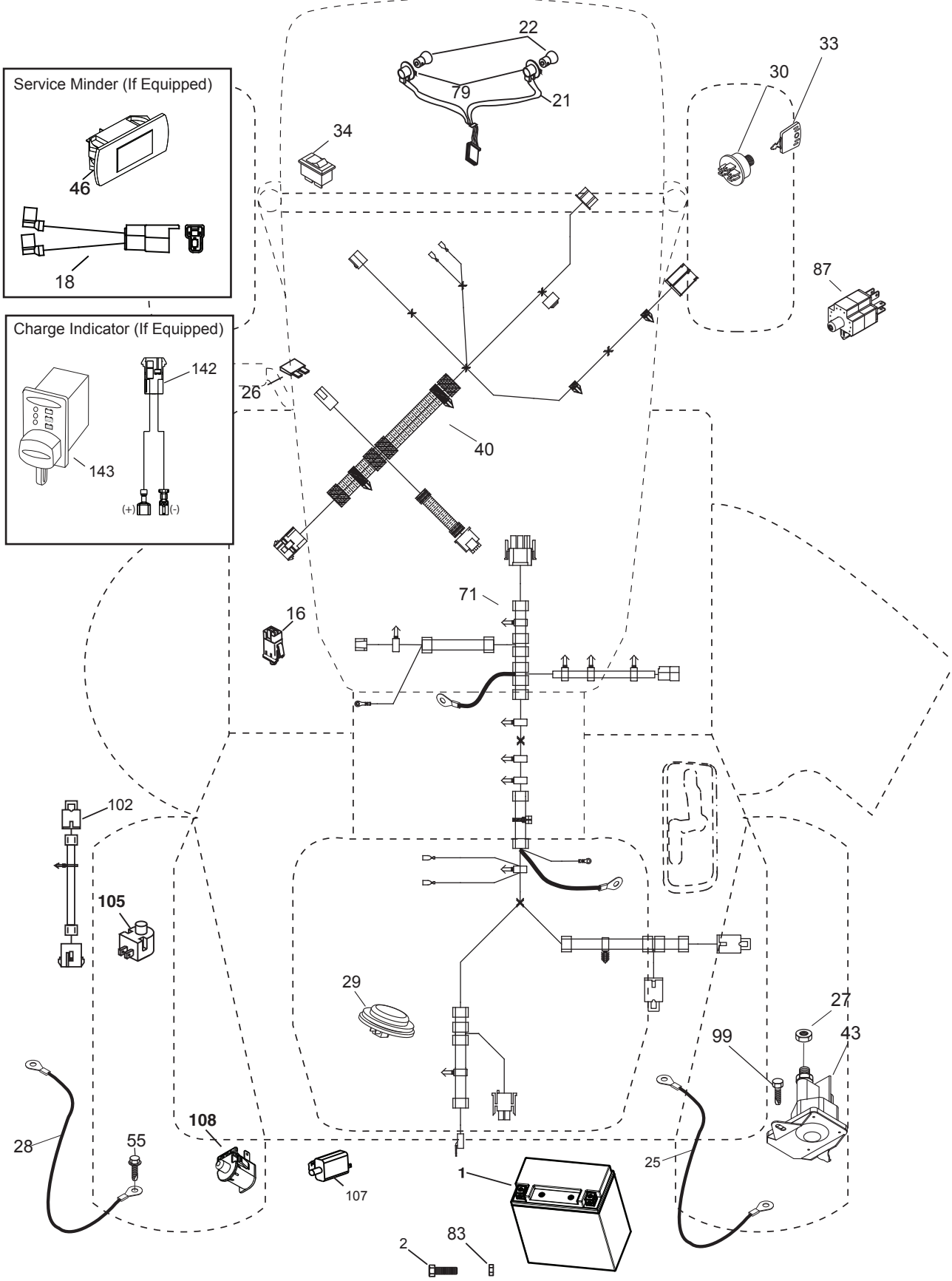
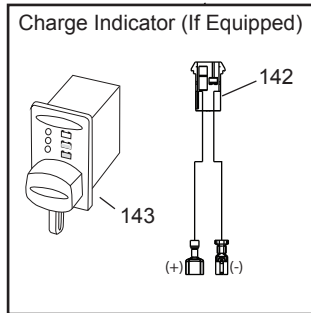
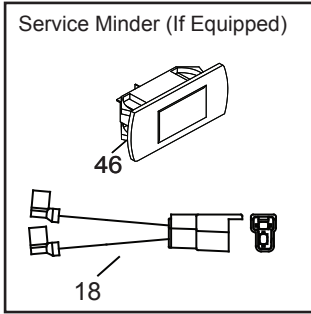

**TRACTOR - MODEL NO. M185-107TC (96051015200), PROD. NO. 960 51 01-52  
ELECTRICAL 32**

<b>KEY NO.</b>	<b>PART NO.</b>	<b>DESCRIPTION</b>
1	532 43 71-57	Battery
2	532 44 09-23	Screw Hex Hd Cap M6 x 1.12mm
16	532 17 61-38	Switch Interlock
21	532 40 02-52	Harness Asm Light w/4152J
22	532 00 41-52	Bulb Light #1156
25	532 44 13-82	Cable Battery 8 AWG 20"-Red
26	532 17 51-58	Fuse
27	873 51 04-00	Nut Keps Hex 1/4-20 unc
28	532 44 13-83	Cable Ground 8 AWG 20"-Black
29	532 40 15-45	Switch Seat
30	532 19 33-50	Switch Ignition
33	532 41 19-35	Key/Chain
34	532 11 07-12	Switch Light
40	532 42 10-02	Harness Ignition Dash
43	582 04 28-01	Solenoid
55	817 06 05-12	Screw 5/16-18 x 3/4
71	581 02 33-01	Harness Chassis
79	532 17 52-42	Socket Asm.
83	532 43 67-74	Nut Square M6 x 1 x 8.5 x 11mm
87	532 42 10-60	Switch Railmount
99	817 00 05-12	Screw Hx Wsh Thdr 5/16-18 x 3/4
102	581 02 35-01	Harness Pigtail
105	532 40 75-68	Switch Reverse
107	532 18 03-79	Switch Full Bagger Indicator
108	532 42 10-62	Switch Snapmount

**NOTE:** All component dimensions given in U.S. inches  
1 inch = 25.4 mm

**TRACTOR - MODEL NO. M185-107TC (96051015200), PROD. NO. 960 51 01-52**  
**CHASSIS AND ENCLOSURES 39**

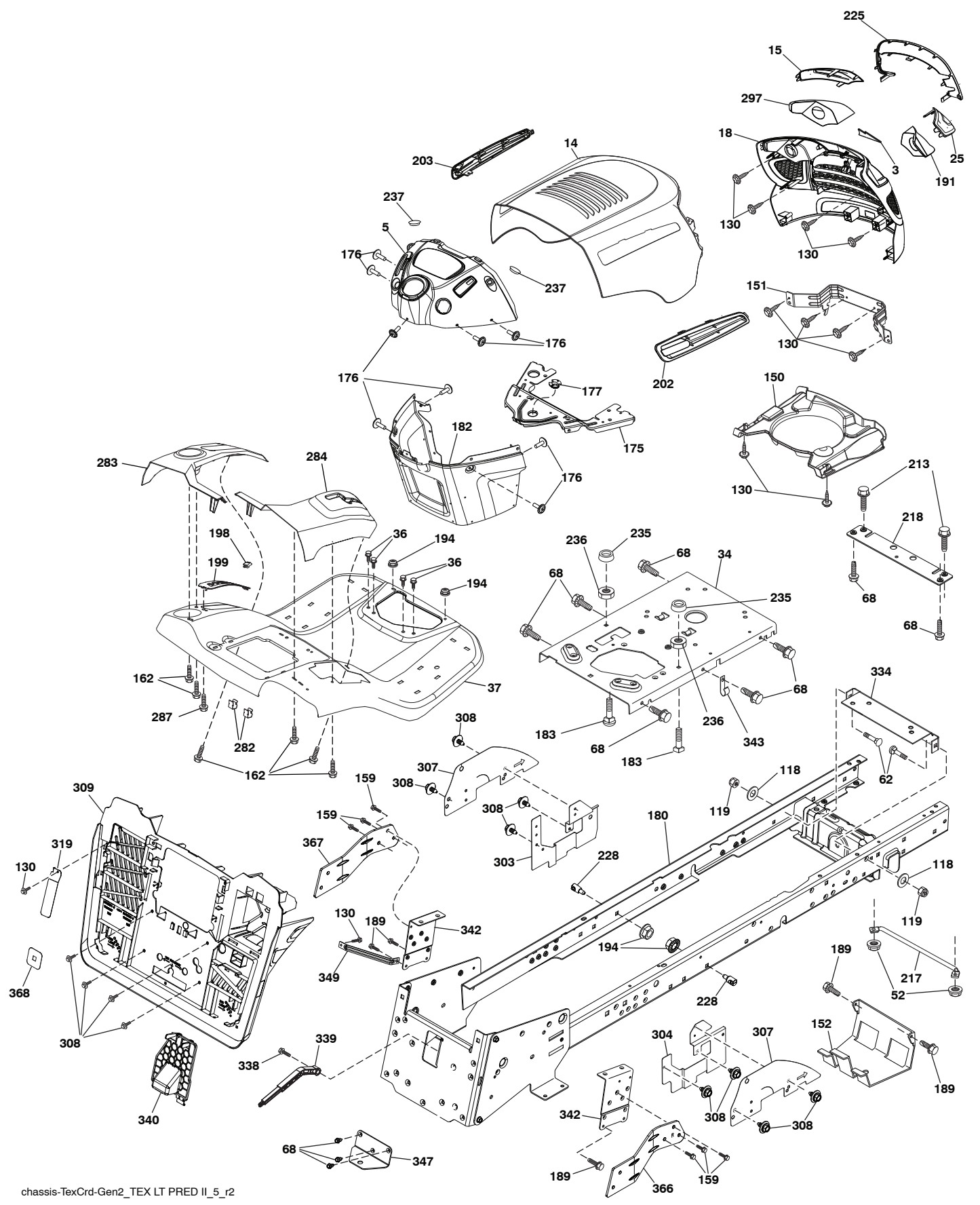

**TRACTOR - MODEL NO. M185-107TC (96051015200), PROD. NO. 960 51 01-52  
CHASSIS AND ENCLOSURES 39**

KEY NO.	PART NO.	DESCRIPTION	KEY NO.	PART NO.	DESCRIPTION
3	578 89 71-01	Emblem Mount	218	532 19 63-95	X-Piece Hood Stop
5	532 40 95-97	Dash	225	581 05 62-01	Trim Ring
14	581 56 47-01	Hood	228	532 19 51-61	Stud Fastener
15	581 05 58-01	Lens LH	235	532 40 61-29	Spacer Fender
18	581 05 57-01	Grille	236	873 93 05-00	Nut Lock 5/16-18 unc
25	581 05 59-01	Lens RH	237	532 40 37-04	Plug Mount Cargo
34	580 91 09-01	Plate Engine	282	532 41 41-10	Clip Retainer
36	817 06 05-12	Screw 5/16-18 x 3/4	283	532 44 76-71	Console Deck Lift
37	532 44 08-49	Fender	284	532 44 72-11	Console Shift RH
52	873 68 05-00	Nut Crown Lock 5/16	287	817 60 04-06	Screw Hex Washhead 1/4-20 x 3/8
62	872 11 06-08	Bolt 3/8-16 x 1 Gr. 5	297	581 05 60-01	Insert Reflective LH
68	539 99 08-58	Screw Thdrol 5/16-18 x 1/2	303	587 49 31-02	Shield, Chassis French LH
118	819 13 13-16	Washer 13/32 x 13/16 x 16 Ga.	304	589 41 30-01	Shield, Chassis French RH
119	873 68 06-00	Nut 3/8-16 unc	307	587 49 45-01	Shield, Chassis Upper
130	532 41 63-58	Screw #10 x 0.750 BOS Thread	308	532 17 18-77	Bolt 5/16-18 unc x 3/4
150	532 40 02-67	Duct, Air	309	581 32 89-11	Backplate Bagger
151	532 18 75-68	Bracket Pivot Hood	319	581 31 39-06	Lever Bagger
152	532 19 95-35	Shield Browning	334	532 44 25-37	Engine Plate
159	817 00 06-12	Screw Hexwsh Thdr 3/8-16 x 3/4	338	532 43 66-40	Bolt Shoulder
162	532 14 24-32	Screw Hex Wsh. Hi-Lo 1/4 x 1/2 unc	339	532 43 66-41	Lever Bagger Full
175	532 19 94-72	Crossmember	340	581 32 90-01	Door Battery
176	532 40 07-76	Screw 10-24 x 5/8	342	582 82 68-02	Support Fender
177	532 19 52-28	Bushing Steering	343	532 44 07-49	Clip
180	582 74 61-01	Chassis	347	532 44 28-87	Hitch
182	532 40 71-76	Dash Lower	349	532 43 66-06	Bracket, Support
183	874 52 05-20	Bolt 5/16-18 x 1-1/4	366	581 31 46-02	Bracket RH Front Bagger
189	817 00 05-12	Screw 5/16-18 x 3/4	367	581 31 45-02	Bracket LH Front Bagger
191	581 05 60-02	Insert Reflective RH	368	581 42 48-01	Full Lever Bagger
194	873 90 05-00	Nut Lock Hex Flange 5/16-18	- -	532 40 09-44	Bumper
198	532 44 80-48	Indicator Deck Lift			
199	532 41 87-39	Plate Deck Lift			
202	588 98 86-01	Vent Hood RH			
203	588 98 86-02	Vent Hood LH			
213	874 76 05-12	Bolt 5/16-18 x 3/4			
217	532 40 91-67	Rod Pivot Hood			

**NOTE:** All component dimensions given in U.S. inches  
1 inch = 25.4 mm

TRACTOR - MODEL NO. M185-107TC (96051015200), PROD. NO. 960 51 01-52  
DRIVE **40**

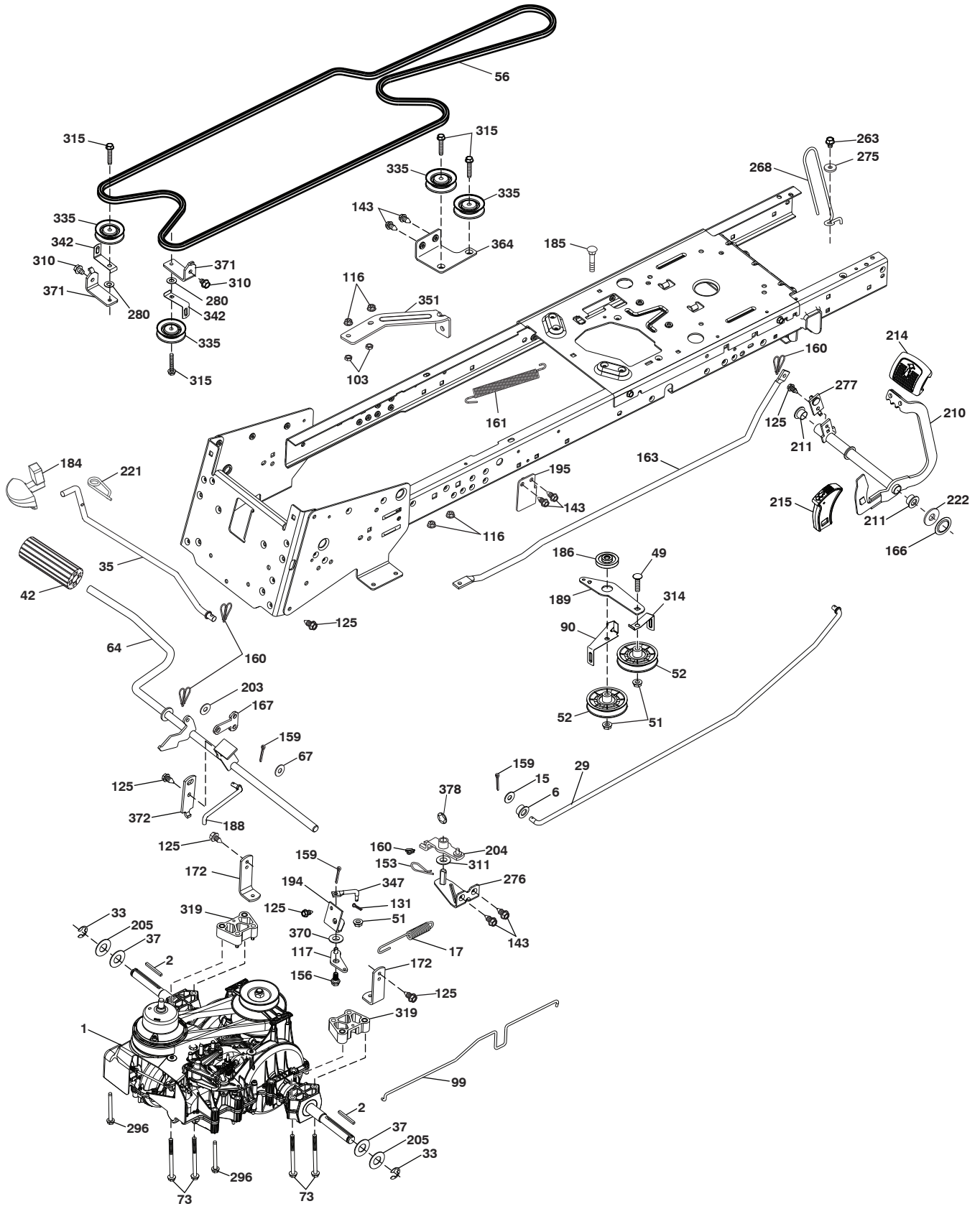

drive-CRD\_VATR\_PEDAL\_22\_r1



**TRACTOR - MODEL NO. M185-107TC (96051015200), PROD. NO. 960 51 01-52  
DRIVE **40****

KEY NO.	PART NO.	DESCRIPTION	KEY NO.	PART NO.	DESCRIPTION
1	---	Transaxle, Gentrans Fast VATR. (582491201) (Order parts from transaxle manufacturer.)	194	583 87 86-01	Bellcrank Brake
2	532 12 35-83	Key Square .2.0 x .1845/.1865	195	580 45 69-02	Brake Bracket
6	532 12 40-28	Bushing Snap	203	819 11 11-16	Washer 11/32 x 11/16 x 16 Ga.
15	819 13 13-16	Washer 13/32 x 13/16 x 16 Ga.	204	584 99 70-01	Link Pivot Pedal
17	580 32 52-01	Spring Brake	205	532 12 17-48	Washer 25/32 x 1-5/8 x 16 Ga.
29	581 50 35-01	Rod Brake	210	588 92 10-01	Pedal Asm Rocker VATR
33	812 00 00-01	E-Ring. #5133-75	211	532 12 01-83	Bearing Nylon
35	532 40 10-31	Rod Control Parking	214	532 42 12-63	Pedal Forward Pad
37	532 18 89-67	Washer Harden .793 x 1.637 x 060	215	582 53 28-01	Cap Pedal Reverse
42	532 12 48-72	Cover Pedal Blk Round	221	532 40 31-87	Retainer Spring Clip Handle
49	872 11 06-14	Bolt Rdhd 3/8-16 Unc x 1-3/4.Gr 5	222	879 21 20-10	Washer 21/32 x 1-1/4 10 Ga.
51	873 90 06-00	Nut, Hex, Flangelock 3/8-16	263	817 00 06-12	Screw Hxwsh Thdr 3/8-16 x 3/4
52	532 19 43-26	Idler V-Groove Offset	268	532 18 24-02	Guard Muffler
56	532 44 69-91	Belt Drive	275	819 13 16-14	Washer 13/32 x 1 x 14 Ga.
64	589 67 14-01	Shaft Asm. Pedal Brake	276	590 63 01-02	Bracket Control Pedal
67	582 58 01-01	Washer Nylon 13/32 x 13/16 x 1.09	277	532 44 85-00	Subasm. Link Rocker Pedal
73	580 83 04-01	Bolt Shoulder Transaxle	280	819 11 10-12	Washer 11/32 x 5/8 x 12 Ga.
90	532 44 36-05	Keeper Belt	296	532 42 04-71	Screw Thdrol 5/16-18 x 3
99	580 35 40-01	Rod Bypass	310	817 49 06-08	Screw Thdrol 3/8-16 x 1/2
103	873 35 05-00	Nut Hex Jam 5/16-18 UNC	311	585 07 20-01	Washer Nylon
116	873 90 05-00	Nut, Lock Hex Flange 5/16-18 unc	314	532 44 47-13	Keeper Belt
117	580 38 29-01	Subasm Bellcrank Brake	315	817 58 05-20	Screw Thdrol 5/16-18 x 1.25
125	817 00 05-12	Screw 5/16-18 x 3/4 Smgml Tap/Bl	319	580 45 74-01	Spacer Transaxle
131	876 02 03-08	Pin Cotter 3/32 x 1/2	335	532 19 95-34	Pulley V-Idler
143	539 99 08-58	Screw Thdrol 5/16-18 x 1/2 Tytt	342	580 96 10-02	Keeper Belt Idler
153	532 12 49-61	Retainer Clip	347	580 32 51-01	Rod Connecting Brake
156	580 36 90-01	Bolt Shoulder Brake	351	532 43 69-98	Bracket Swaybar
159	876 02 04-12	Pin Cotter 1/8 x 3/4	364	532 44 30-32	Bracket Idler
160	532 16 94-84	Retainer Clip(M).Dia.290	370	878 12 16-32	Washer Thrust 3/8 x 1 x .032
161	532 10 57-09	Spring Return Clutch 6.75	371	580 96 07-02	Bracket Idler CRD VATR
163	532 44 82-72	Rod Control Pedal	372	581 47 52-01	Arm Control Brake
166	532 42 91-64	Nut Push .625	378	584 28 77-01	Nut Push
167	532 40 52-57	Latch Brake Parking			
172	532 44 82-76	Strap Torque LH/RH			
184	532 41 14-84	Handle Parking Brake			
185	872 11 06-22	Bolt Rdhd.3/8-16 Unc x 2-3/4 Gr.5			
186	532 19 43-21	Spacer Retainer			
188	582 21 70-01	Link Clutch Ground Drive Long			
189	532 43 36-11	Bellcrank Groundrive			

**NOTE:** All component dimensions given in U.S. inches  
1 inch = 25.4 mm

**TRACTOR - MODEL NO. M185-107TC (96051015200), PROD. NO. 960 51 01-52**  
**ENGINE 24**

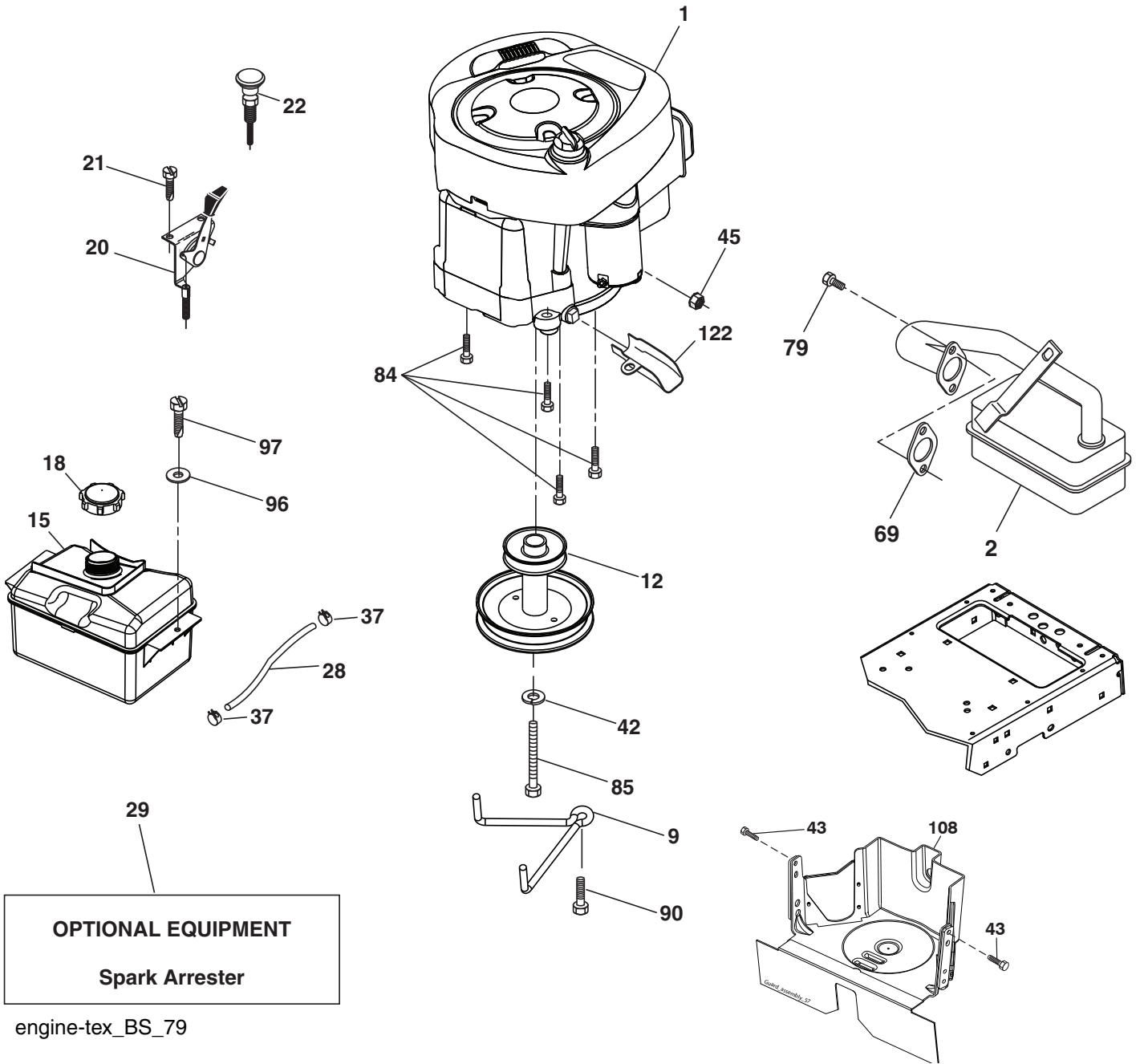

engine-tex\_BS\_79

**TRACTOR - MODEL NO. M185-107TC (96051015200), PROD. NO. 960 51 01-52  
ENGINE 24**

KEY NO.	PART NO.	DESCRIPTION
1	-----	Engine Briggs Model 31R807-0008-B1 (585688901) (Order parts from engine manufacturer.)
2	532 13 73-52	Muffler
9	583 84 78-01	Keeper Belt Engine
12	586 47 85-01	Pulley Engine
15	581 28 99-01	Tank Fuel
18	532 43 02-20	Cap Fuel
20	532 18 38-97	Control Throttle
21	532 41 63-58	Screw #10 x 0.750
22	532 19 49-81	Control Choke
28	532 13 70-40	Line Fuel
29	532 13 71-80	Kit Spark Arrester (Flat Scrn)
37	532 12 34-87	Clamp Hose Blk
42	539 99 02-47	Washer SLW STD 7/16
43	817 06 05-16	Screw 5/16-18 x 1 Smgml Tap
45	873 51-04-00	Nut Keps Hex 1/4-20 unc
69	532 16 52-91	Gasket Muffler
79	532 19 23-34	Screw Socket Hd 5/16-18 x .75
84	817 06 06-20	Screw 3/8-16 x 1-1/4
85	501 60 65-01	Bolt 7/16-20 x 4 x Gr. 5
90	817 00 06-16	Screw 3/8-16 x 1
96	819 09 14-16	Washer 9/32 x 7/8 x 16 Ga.
97	817 67 04-12	Screw Hexwsh Thdrol 1/4-20 x 3/4
108	587 17 95-10	Cover Pulley Engine w/SHLD
122	532 42 19-22	Extension Drain Oil

**NOTE:** All component dimensions given in U.S. inches  
1 inch = 25.4 mm

**Engine Power Rating Information**

The gross power rating for individual gas engine models is labeled in accordance with SAE (Society of Automotive Engineers) code J1940 (Small Engine Power & Torque Rating Procedure), and rating performance has been obtained and corrected in accordance with SAE J1995 (Revision 2002-05). Torque values are derived at 3060 RPM; horsepower values are derived at 3600 RPM. Actual gross engine power will be lower and is affected by, among other things, ambient operating conditions and engine-to-engine variability. Given both the wide array of products on which engines are placed and the variety of environmental issues applicable to operating the equipment, the gas engine will not develop the rated gross power when used in a given piece of power equipment (actual "on-site" or net power). This difference is due to a variety of factors including, but not limited to, accessories (air cleaner, exhaust, charging, cooling, carburetor, fuel pump, etc.), application limitations, ambient operating conditions (temperature, humidity, altitude), and engine-to-engine variability. Due to manufacturing and capacity limitations, Briggs & Stratton may substitute an engine of higher rated power for this Series engine.

TRACTOR - MODEL NO. M185-107TC (96051015200), PROD. NO. 960 51 01-52  
STEERING ASSEMBLY **41**

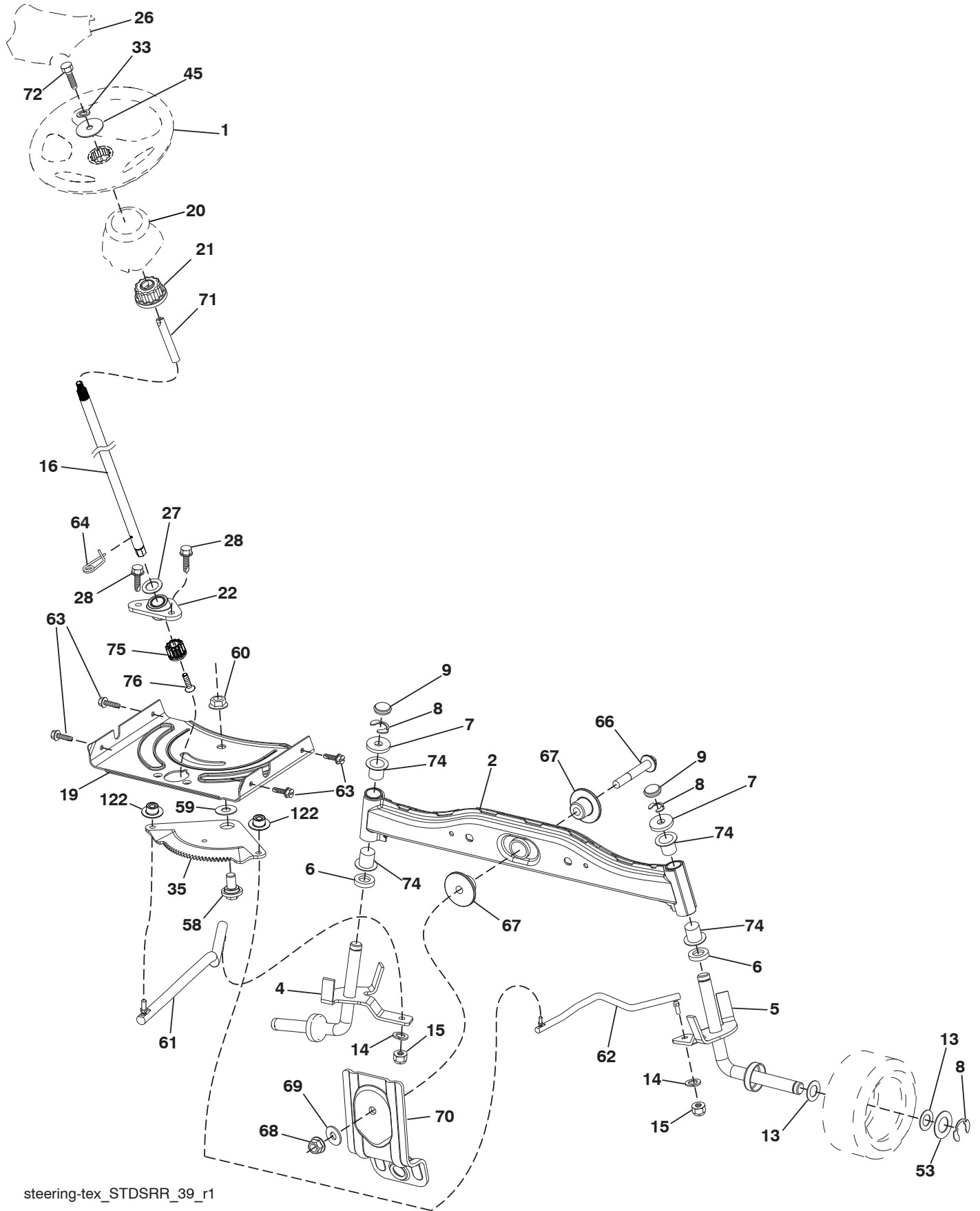

steering-tex\_STDSRR\_39\_r1

**TRACTOR - MODEL NO. M185-107TC (96051015200), PROD. NO. 960 51 01-52**  
**STEERING ASSEMBLY 41**

<b>KEY NO.</b>	<b>PART NO.</b>	<b>DESCRIPTION</b>
1	532 42 45-51	Wheel, Steering
2	532 41 81-68	Axle Asm., Front
4	532 40 30-87	Spindle Asm., LH
5	532 40 30-88	Spindle Asm., RH
6	532 12 49-31	Bearing, Race Thrust Harden
7	532 12 17-48	Washer 25/32 x 1-5/8 x 16 Ga.
8	812 00 00-29	Ring, Klip #T5304-75
9	532 12 12-32	Cap, Spindle
13	532 12 17-49	Washer 25/32 x 1-1/4 x 16 Ga.
14	539 99 01-18	Washer, SLW ZD 3/8
15	873 54 06-00	Nut, Crown Lock 3/8-24 unf
16	585 86 92-02	Steering Shaft
19	532 19 47-29	Plate Steering
20	532 40 97-63	Boot, Steering
21	532 18 67-37	Adapter Wheel Steering
22	585 02 98-02	Bearing
26	532 42 45-53	Insert, Wheel Cap
27	819 21 16-16	Washer
28	817 00 06-12	Screw 3/8-16 x 3/4
33	539 99 01-87	Washer Lock 5/16
35	532 19 47-32	Gear, Sector Plate
45	819 11 38-12	Washer 11/32 ID 2-3/8 OD 12 Ga.
53	532 18 89-67	Washer Hardened .793 x 1.637 x .060
58	532 19 47-47	Bolt Shoulder Sector Pivot CFM
59	532 19 47-48	Washer Thrust Sector Steering
60	873 97 10-00	Nut Flange Lock 5/8-11
61	532 19 47-40	Draglink, LH
62	532 19 47-41	Draglink, RH
63	817 00 05-12	Screw 5/16-18 x 3/4
64	532 19 98-49	Retainer Clip Spring Steering
66	871 02 07-48	Bolt Hex Fghd 7/16-14 x 3 Serr
67	532 19 47-37	Bushing PM Front Axle
68	873 90 07-00	Nut Lock Flange 7/16-14 Gr. 5
69	532 19 91-62	Washer 1.5 x .505 x .118
70	585 33 88-01	Bracket Deck Susp. Front
71	532 19 07-52	Shaft Extension
72	532 42 89-82	Bolt Fin Hx 5/16-18 x 4
74	532 12 49-37	Bearing
75	580 68 37-01	Pinion
76	580 68 36-01	Screw Head Sock
122	532 44 49-62	Cap Gear Sector

**NOTE:** All component dimensions given in U.S. inches  
1 inch = 25.4 mm

**TRACTOR - MODEL NO. M185-107TC (96051015200), PROD. NO. 960 51 01-52**  
**MOWER DECK 44**

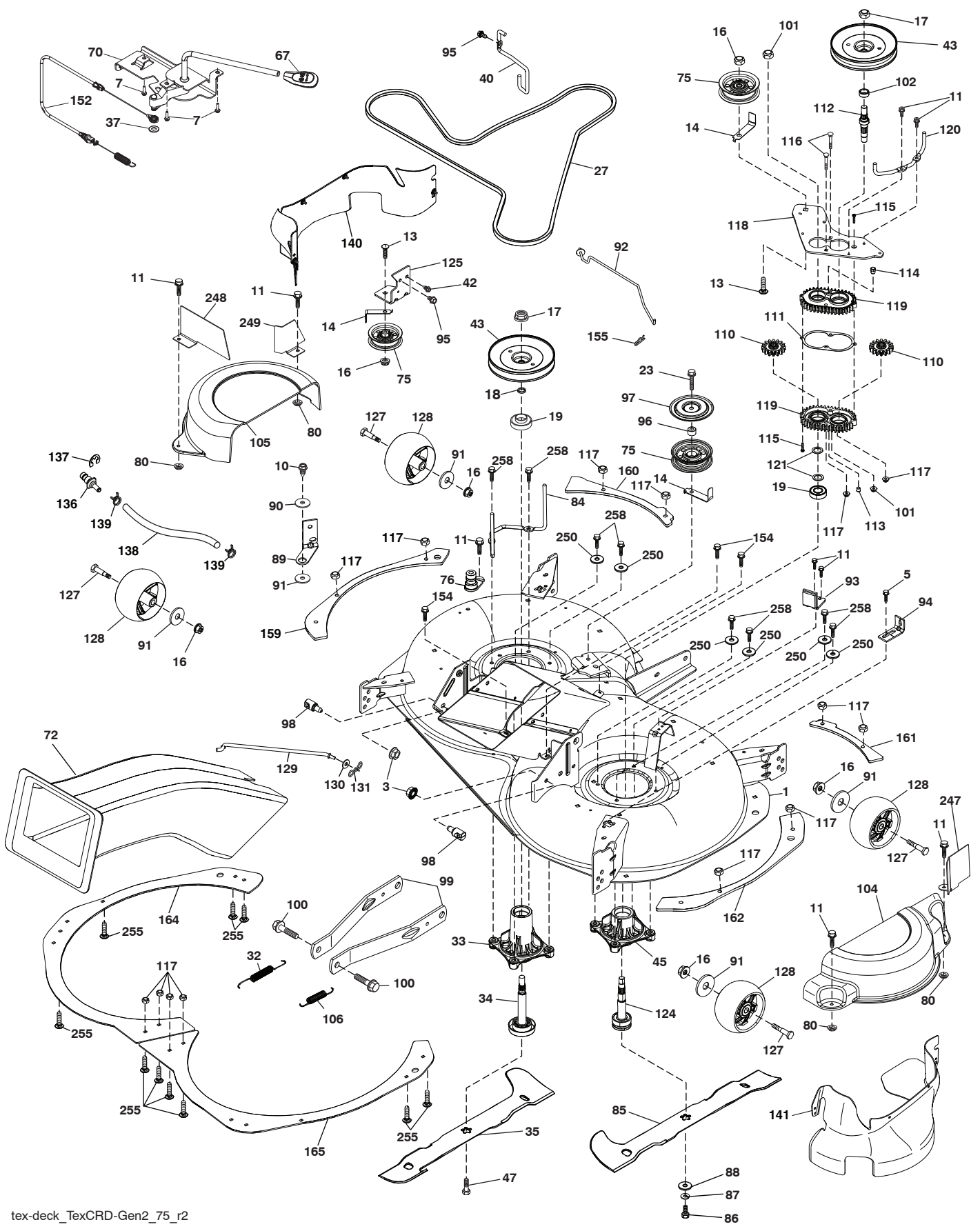

**TRACTOR - MODEL NO. M185-107TC (96051015200), PROD. NO. 960 51 01-52**  
**MOWER DECK 44**

KEY NO.	PART NO.	DESCRIPTION	KEY NO.	PART NO.	DESCRIPTION
1	532 44 77-36	Deck Weldment	115	818 03 10-16	Screw Torx #10-24 x 1
3	873 90 05-00	Nut Lock Hex Flange 5/16-18	116	872 11 04-14	Bolt 1/4-20 x 1.75 Gr. 5
5	817 00 05-10	Bolt 5/16-18	117	873 90 04-00	Nut Hex Flg. 1/4-20 unc
7	532 41 63-58	Screw #10 x 0.750 BOS Thread	118	532 44 32-32	Arm Clutching
10	817 00 06-16	Screw 3/8-16 x 1 smgml tap	119	532 43 81-66	Gearcase Subasm
11	532 13 77-29	Screw Thd Roll 1/4-20 X 5/8	120	532 44 32-36	Keeper Belt RH
13	872 11 06-12	Bolt Carr Sh 3/8-16 X 1-1/2 Gr. 5	121	532 43 69-85	Washer
14	532 15 60-85	Keeper Belt Idler	124	581 65 07-01	Shaft Asm Mndrel Short
16	873 90 06-00	Nut Lock FIG 3/8 - 16 unc	125	532 44 04-20	Bracket Idler Chassis
17	532 40 02-34	Nut Flange Lock Top	127	532 19 34-06	Bolt Shoulder 3/8-16 x 3-5/8 Gr. 5
18	532 18 76-90	Washer Spacer Mandrel	128	589 52 73-01	Wheel Gauge
19	585 32 39-01	Bearing Ball Mandrel	129	532 44 32-37	Rod Anti-Sway
23	817 49 06-28	Screw Thdrol 3/8-16 X 1-3/4	130	819 13 13-12	Washer 13/32 x 13/16 x 12 Ga.
27	532 44 58-80	V-Belt Drive	131	532 19 42-08	Pin Cotter 5/16 Bow Tie Lock
32	532 40 18-72	Spring Return Deck	136	532 43 96-39	Washout Port Remote
33	580 79 61-01	Mandrel Asm. Tall	137	812 00 00-29	Ring Klip
34	580 85 47-01	Shaft Asm Mndrel Tall	138	532 44 76-67	Washout Port Hose
35	581 51 79-01	Blade Mower LH	139	532 44 07-42	Hose Clamp
37	819 13 13-16	Washer 13/32 x 13/16 x 16 Ga.	140	501 58 00-01	Guard French LH
40	532 19 72-58	Keeper Belt Engine LH	141	501 57 96-02	Guard French RH
42	817 00 05-12	Screw 5/16-18 x 3/4	152	532 44 76-66	Cable Clutch Manual w/Spring
43	532 44 32-39	Pulley Mandrel	154	532 19 98-55	Screw Thd Roll 1/4-20 x 1/2
45	581 65 05-01	Mandrel Asm. Short	155	532 12 47-88	Retainer Spring
47	584 30 93-01	Screw	159	585 30 95-05	Reinforce Plate LHS Bolt
67	532 40 30-12	Handle Clutch Cable	160	585 30 94-05	Reinforce Plate LH Front
70	532 40 12-46	Clutch Asm Manual	161	585 31 60-05	Reinforce Plate RH Front
72	581 45 41-03	Chute Upper	162	585 31 61-05	Reinforce Plate RH SD Blt
75	532 13 14-94	Pulley Idler Flat	164	589 35 85-02	Baffle Plate Left
76	532 43 96-40	Washout Port	165	587 42 61-02	Baffle Plate Right
80	532 42 30-62	Palnut	247	589 00 96-02	Guard Steel
84	532 44 32-35	Keeper Belt LH Mandrel	248	581 26 36-02	LH Rear French Steel Guard
85	581 51 80-01	Blade Mower RH	249	581 26 35-02	LH Front French Steel Guard
86	532 18 17-13	Bolt 3/8-24 x 1.50 Gr. 8	250	819 11 12-12	Washer 11/32 x 3/4 x 12 Ga.
87	539 99 01-18	Washer SLW ZD 3/8	255	539 10 98-00	Carriage Bolt 1/4-20 x 1 Gr. 5
88	532 14 02-96	Washer Hard Blade Mower Vented	258	584 95 39-01	Bolt Hex Wsh Hd .313-18 x 1.19
89	532 19 72-61	Arm Brake 97 LH	--	587 12 61-05	Mandrel Assembly-Tall(Includes Housing (key #33), Shaft Assembly (key #34), and Bearing (key #19) Only - Pulley/Nut/Washer And Blade Bolt/Washers Not Included)
90	532 19 90-92	Spacer Retainer	--	581 65 05-01	Mandrel Assembly-Short(Includes Housing (key #45), Shaft Assembly (key #124), and Bearing (key #19) Only - Pulley/Nut/Washer And Blade Bolt/Washers Not Included)
91	819 13 20-12	Washer 13/32 x 1-1/4 x 12 Ga.	--	532 44 81-32	Gear Case Kit. Use .75 oz. Shell 460 Oil. (Include Gear Output (key #110), Gasket Gearcase (key #111), Shaft Gearcase (key #112), Plug Oil (key #113), Vent Breather 1/8 NPT (key #114), Screw Torx (key #115), Gearcase Subasm (key #119). Replacement Mower Complete
92	532 44 32-33	Rod Brake Assembly			
93	532 43 81-25	Arm Brake RH			
94	532 19 72-50	Bracket Clutch Cable			
95	817 00 06-12	Screw 3/8-16 x 3/4			
96	532 40 02-71	Spacer			
97	532 18 20-61	Shield Idler Mower			
98	532 19 51-61	Stud Fastener			
99	532 19 51-86	Arm Suspension Mower Rear			
100	532 19 65-39	Bolt Shoulder			
101	873 68 09-00	Nut Crownlock 9/16 - 18 unc			
102	532 40 25-11	Spacer Bearing Swing Plate			
104	581 71 40-01	Mandrel Cover RH			
105	532 44 47-55	Mandrel Cover LH			
106	532 19 32-16	Spring Brake Return			
110	587 93 48-01	Gear Output			
111	532 43 69-79	Gasket Gearcase			
112	532 44 38-52	Shaft Gearcase Adapter			
113	532 43 85-33	Plug Oil			
114	588 17 05-01	Valve Relief			

**NOTE:** All component dimensions given in U.S. inches  
1 inch = 25.4 mm

**TRACTOR - MODEL NO. M185-107TC (96051015200), PROD. NO. 960 51 01-52**  
**MOWER LIFT 45**

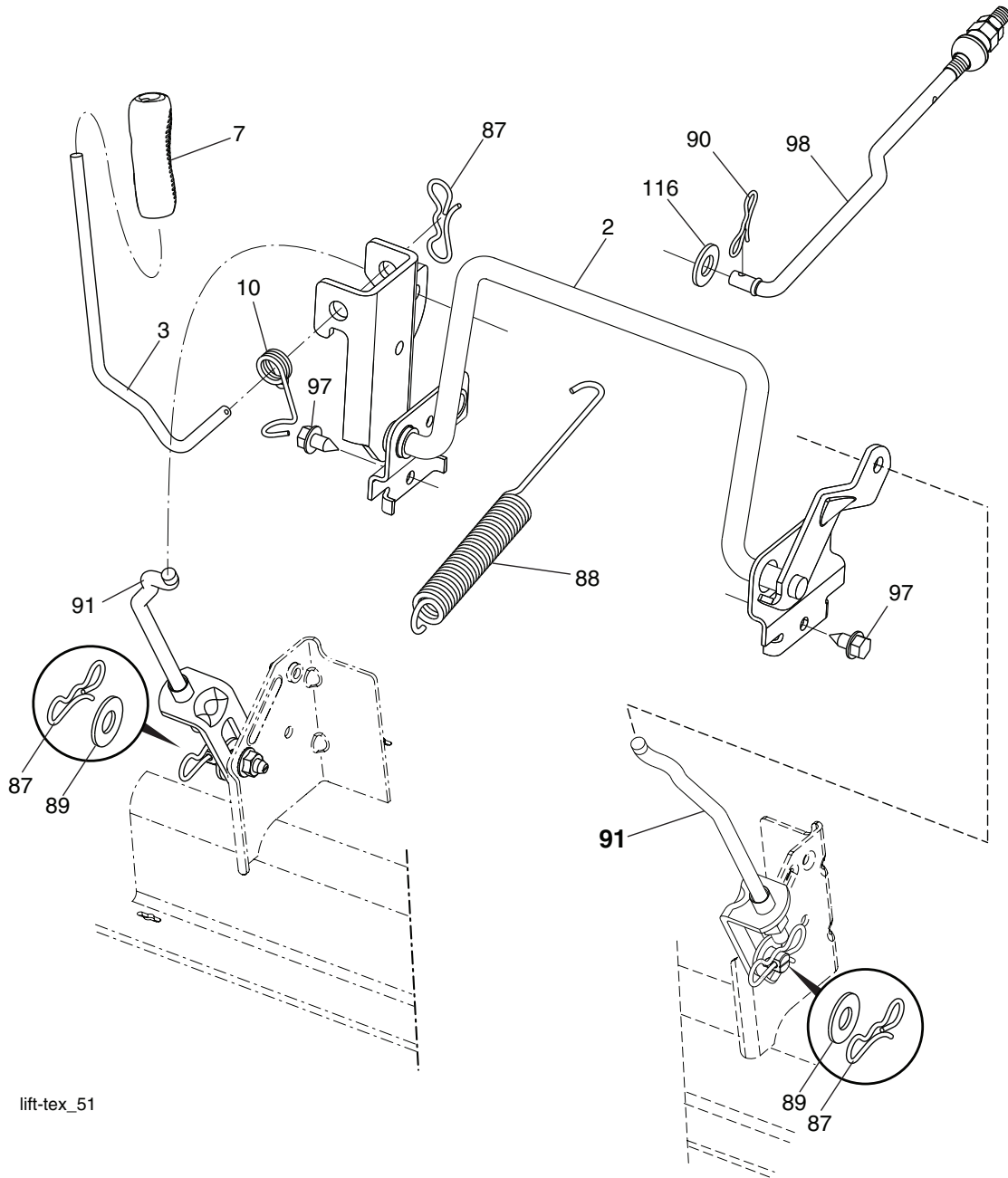

lift-tex\_51

KEY NO.	PART NO.	DESCRIPTION
2	532 43 69-96	Deck Lift
3	532 19 52-31	Lever Asm., Lift RH
7	580 96 23-01	Grip, Lever
10	532 19 63-14	Spring Torsion
87	532 19 42-09	Pin Cotter 7/16 Bow Tie Lock
88	532 44 54-96	Spring Lift Assist
89	819 19 19-12	Washer 17/32 x 1-3/16 x 12 Ga.
90	532 19 42-08	Pin Cotter 5/16 Bow Tie Lock

KEY NO.	PART NO.	DESCRIPTION
91	532 19 51-81	Link Lift Susp Mower Rear
97	817 49 06-08	Screw 3/8-16 x 1/2
98	532 42 05-25	Link Lift Susp. Front Mower
116	819 15 15-16	Washer 15/32 x 15/16 x 16 Ga.

**NOTE:** All component dimensions given in U.S. inches  
 1 inch = 25.4 mm



**TRACTOR - MODEL NO. M185-107TC (96051015200), PROD. NO. 960 51 01-52**  
**SEAT ASSEMBLY 42**

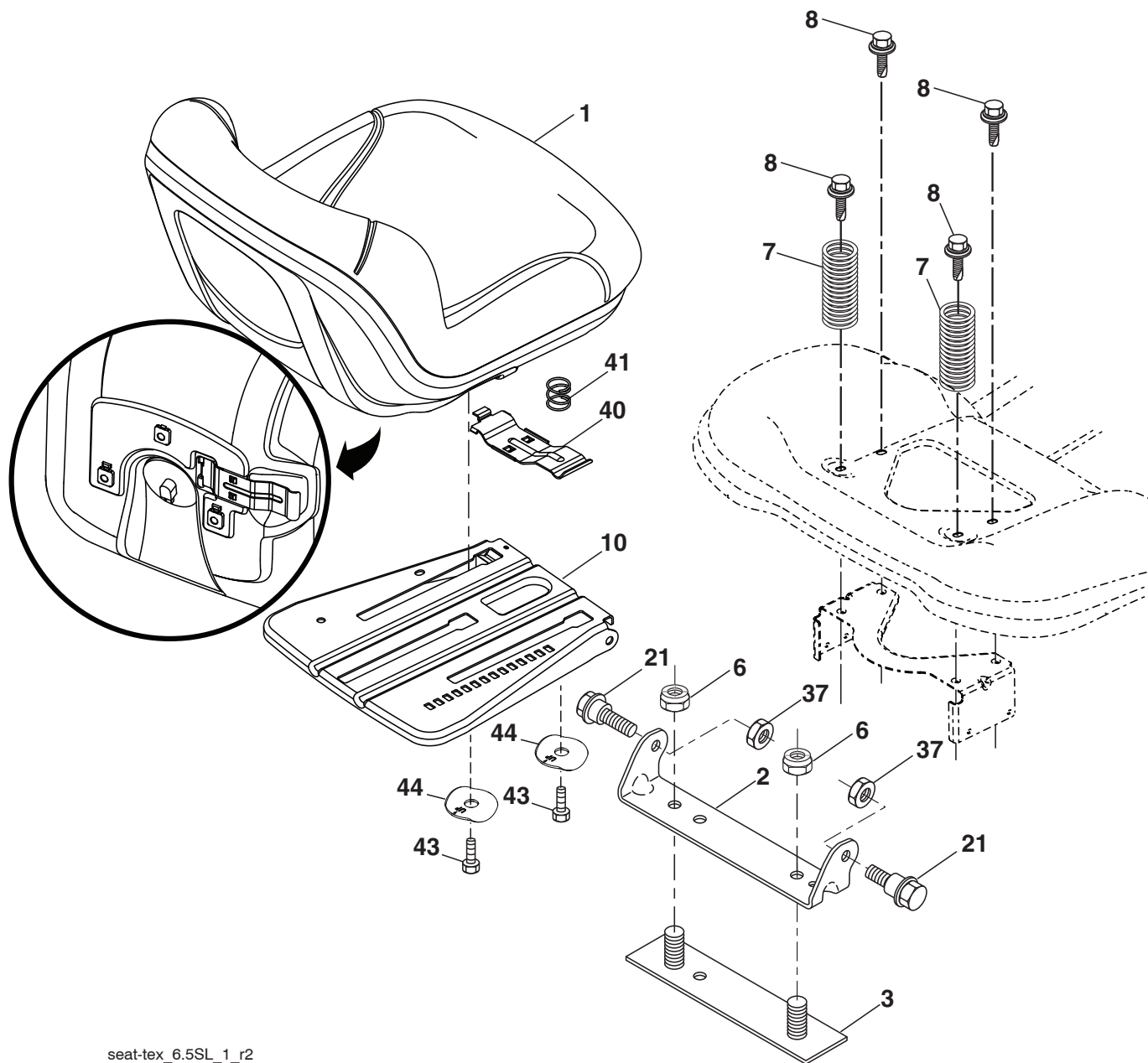

seat-tex\_6.5SL\_1\_r2

KEY NO.	PART NO.	DESCRIPTION
1	581 46 22-01	Seat
2	532 18 01-66	Bracket Pnt Pivot Fender
3	532 14 06-75	Strap Asm. Fender
6	873 80 06-00	Nut Lock Hex w/Ins 3/8-16
7	589 48 35-01	Spring Seat
8	532 17 18-77	Bolt 5/16-18 unc x 3/4
10	587 23 20-02	Pan Pnt Seat
21	587 90 78-01	Bolt Shoulder 5/16-18 x 5/8

KEY NO.	PART NO.	DESCRIPTION
37	873 80 05-00	Nut Hex Lock w/Ins 5/16-18
40	532 19 76-61	Handle Slide
41	532 19 82-00	Spring Latch
43	874 76 06-12	Bolt 3/8-16 unc x 3/4
44	501 05 18-01	Washer, Winged 3/8 ID 1.5 OD

**NOTE:** All component dimensions given in U.S. inches  
 1 inch = 25.4 mm

TRACTOR - MODEL NO. M185-107TC (96051015200), PROD. NO. 960 51 01-52  
BAGGER **46**

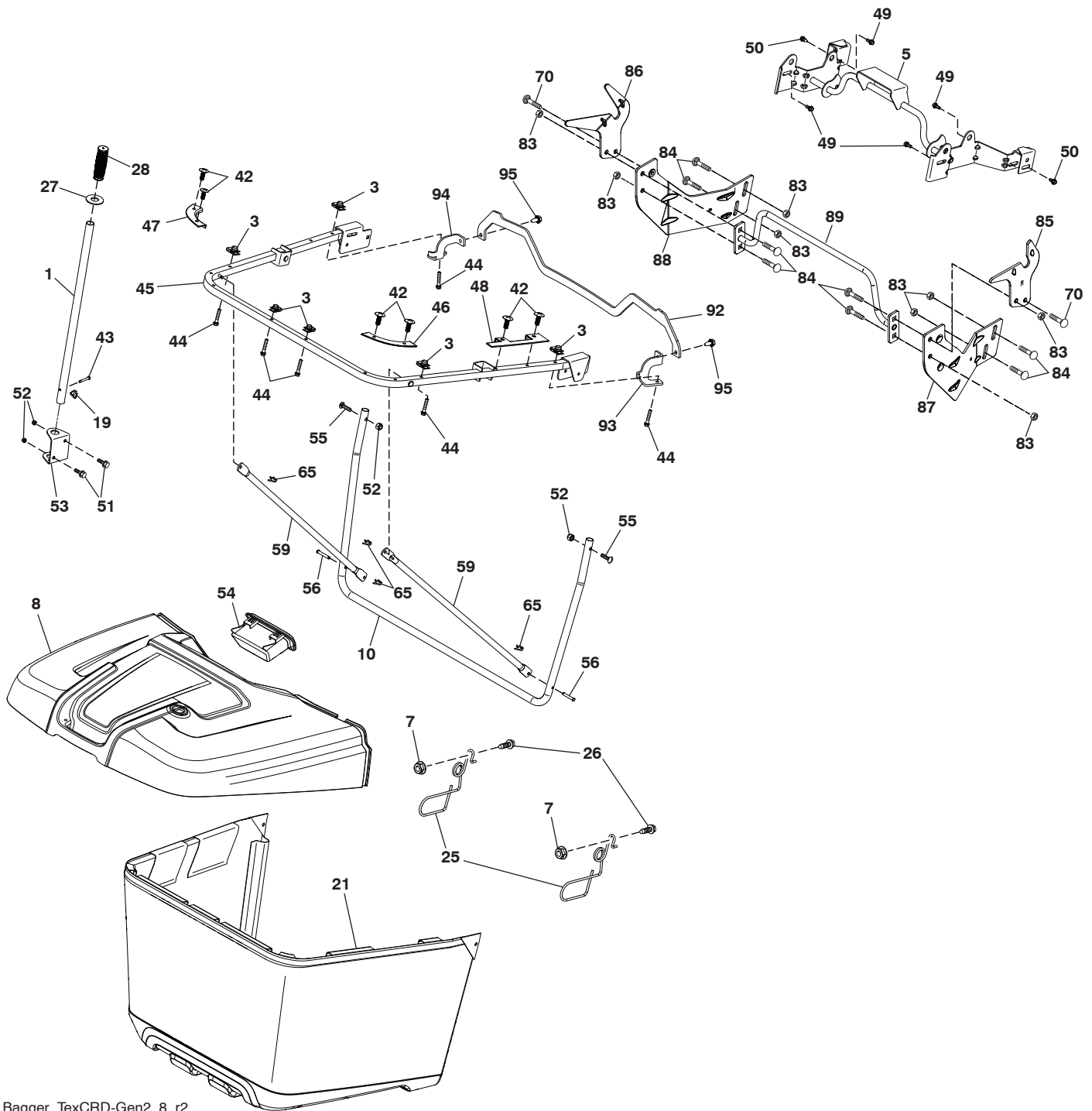

Bagger\_TexCRD-Gen2\_8\_r2

**TRACTOR - MODEL NO. M185-107TC (96051015200), PROD. NO. 960 51 01-52  
BAGGER 46**

<b>KEY NO.</b>	<b>PART NO.</b>	<b>DESCRIPTION</b>
1	532 42 86-10	Tube Handle Bagger
3	532 17 48-14	Nut Push
5	532 44 37-62	Frame Asm Top Bagger
7	873 90 04-00	Nut Hex Flange 1/4-20 unc
8	532 44 78-28	Cover Bagger
10	532 44 37-55	Frame Front
19	532 19 42-08	Cotter Pin 5/16 Bow Tie
21	581 33 71-04	Bag Asm
25	532 44 55-28	Latch Bagger
26	817 49 04-12	Screw Hexwsh Thdrol 1 1/4~20 x 3/4
27	532 44 55-29	Grommet Rubber
28	532 16 57-87	Grip Handle Black
42	532 44 04-28	Christmas Tree Clip
43	532 12 68-75	Clevis Pin
44	532 19 96-87	Bolt 1/4-20 1.50
45	532 44 37-54	Upper U Frame Weldment
46	532 44 55-41	Bagger Corner Close-Out RH
47	532 44 40-79	Bagger Corner Close-Out LH
48	532 44 40-80	Top Bagger Side Close-Out
49	532 17 18-73	Bolt Shoulder 5/16~ 18 TT
50	532 17 18-77	Bolt 5/16-18 unc x 3/4 W/SEMS
51	872 11 05-06	Bolt RDHDSQNK 5/16-18 unc x 3/4
52	873 80 05-00	Nut Lock HX W/INS 5/16-18 UNC
53	532 44 41-95	Bracket Dump Handle
54	532 44 75-43	Bagger TOP Front Handle
55	539 10 29-33	RHSNB 5/16-18 x 1-1/2 Gr. 5 ZD
56	532 42 03-06	Pin Clevis .1830DX1.26 long
59	532 44 47-63	Bagger Spread Tube
65	532 12 47-88	Retainer Spring 1" Zinc
70	817 00 06-12	Bolt 3/8-16X3/4
83	873 80 06-00	Nut Lock Hex w/Ins 3/8-16
84	872 11 06-08	Bolt RDHD SQNK 3/8-16 x 1 Gr. 5
85	581 31 44-02	Bracket RH Pivot
86	581 31 43-02	Bracket LH Pivot
87	581 31 48-02	Bracket RH
88	581 31 47-02	Bracket LH
89	581 31 51-04	Tube Asm.
92	586 05 23-02	Bracket Bagger Top Support
93	586 05 24-02	Bracket RH Support
94	586 05 25-02	Bracket LH Support
95	817 00 05-12	Screw 5/16-18 x 3/4

**NOTE:** All component dimensions given in U.S. inches  
1 inch = 25.4 mm

