

# ILLUSTRATED PARTS LIST

**MFG. ID NO. 96051014900**

**CUST. CAT. NO. M125-97TC POWERDRIVE**

**PRODUCT NO. 960 51 01-49**

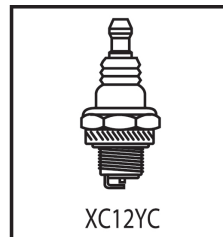
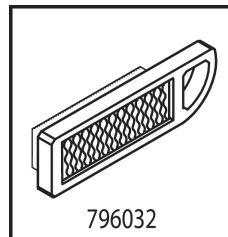

**47**

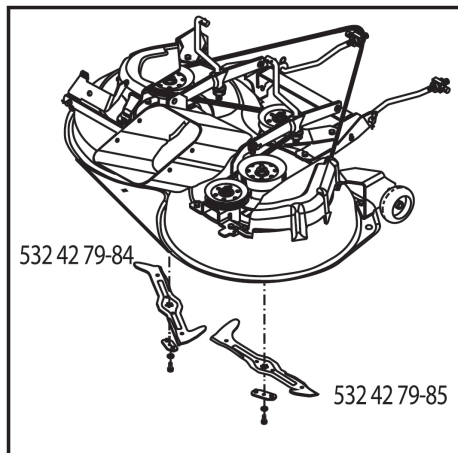
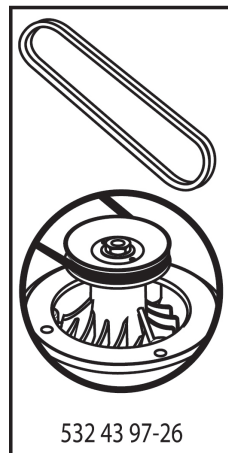
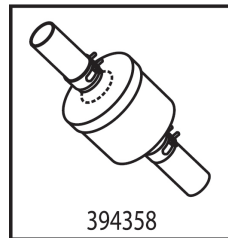

**582879301**

**TRACTOR - MODEL NO. M125-97TC (96051014900), PROD. NO. 960 51 01-49**  
**DECALS 27**

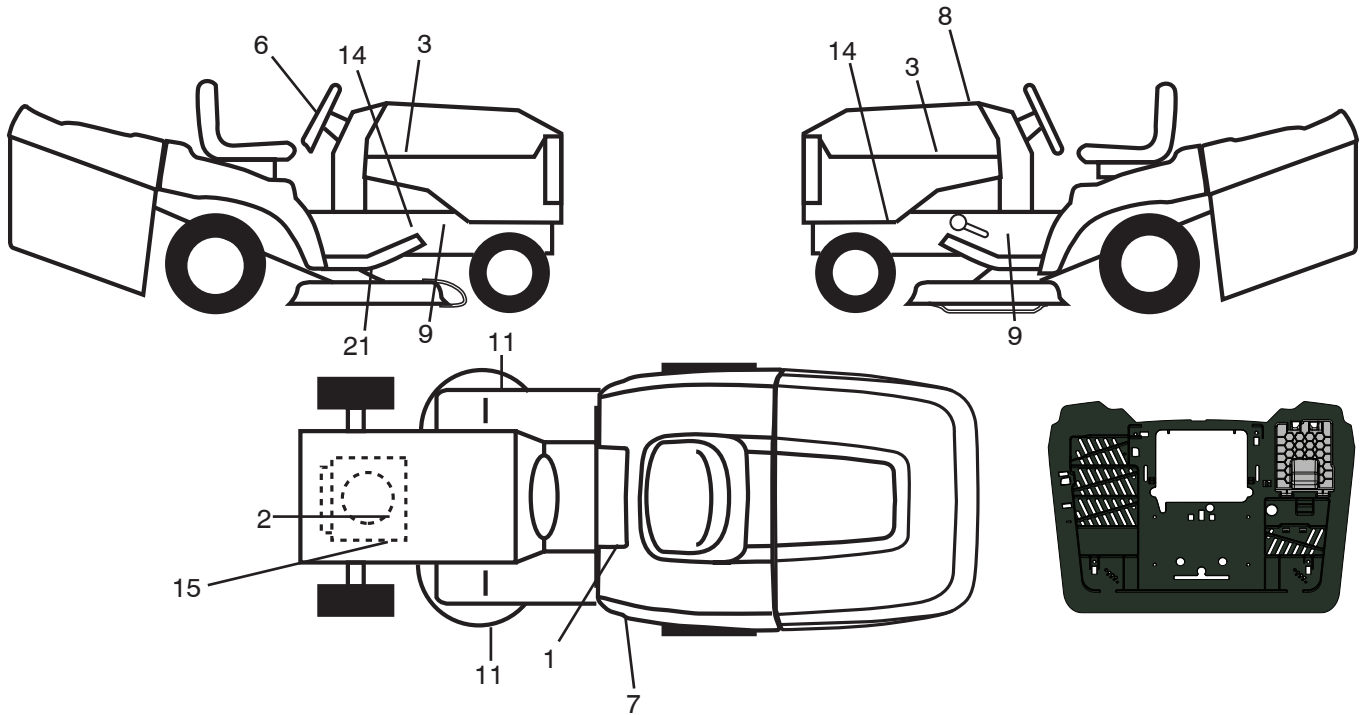

KEY NO.	PART NO.	DESCRIPTION
1	581 57 83-01	Decal, Warning
2	581 57 97-01	Decal, Warning Eng. Sym.
3	581 09 12-01	Decal, Hood RH/LH
6	501 49 43-01	Decal, Steering Wheel
7	581 95 02-01	Decal, Fender
8	582 87 93-01	Decal, Replacement
9	581 57 98-01	Decal, Warning
11	581 57 91-01	Decal, Mower Cut Finger Symbol
14	581 57 96-01	Decal, Chassis Hot Muffler
15	585 56 13-01	Decal, Engine HP

KEY NO.	PART NO.	DESCRIPTION
21	532 44 11-89	Decal, Belt Sch CRD
--	532 44 27-44	Decal, Battery
--	532 42 59-86	Pad Footrest RH
--	532 42 59-76	Pad Footrest LH
--	583 90 19-01	Decal, Bypass
--	588 91 60-01	Decal, Pred LT Hood
--	115 84 28-40	Manual Operator's (Euro)
--	115 84 28-50	Manual Operator's (Scan)
--	115 84 30-20	Manual Operator's (E-Bloc)
--	115 84 31-30	Manual Operator's (Baltic)

**WHEELS & TIRES**

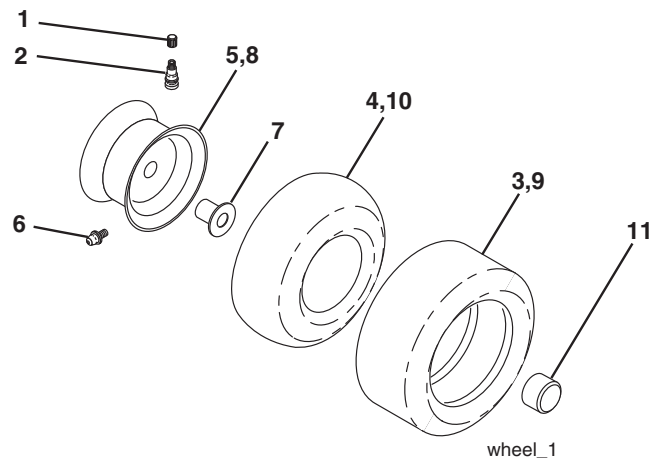

KEY NO.	PART NO.	DESCRIPTION
1	532 05 91-92	Cap Valve Tire
2	532 06 51-39	Stem Valve
3	532 10 62-22	Tire Front 15 x 6-6
4	532 05 99-04	Tube Inner Front #35060
5	532 12 51-21	Rim Asm 6" Front Silver Service
6	532 12 49-57	Fitting Grease
7	532 12 49-59	Bearing Flange
8	532 12 51-22	Rim Asm 8" Rear Silver Service
9	532 12 46-35	Tire Rear 18 x 8.5-8
10	532 12 49-26	Tube Rear 8.5 x 8
11	532 19 32-68	Cap Axle
--	532 14 43-34	Sealant, Tire (10 oz. Tube)

**NOTE:** All component dimensions given in U.S. inches  
 1 inch = 25.4 mm

# TRACTOR - MODEL NO. M125-97TC (96051014900), PROD. NO. 960 51 01-49

## SCHEMATIC 38

SCH17

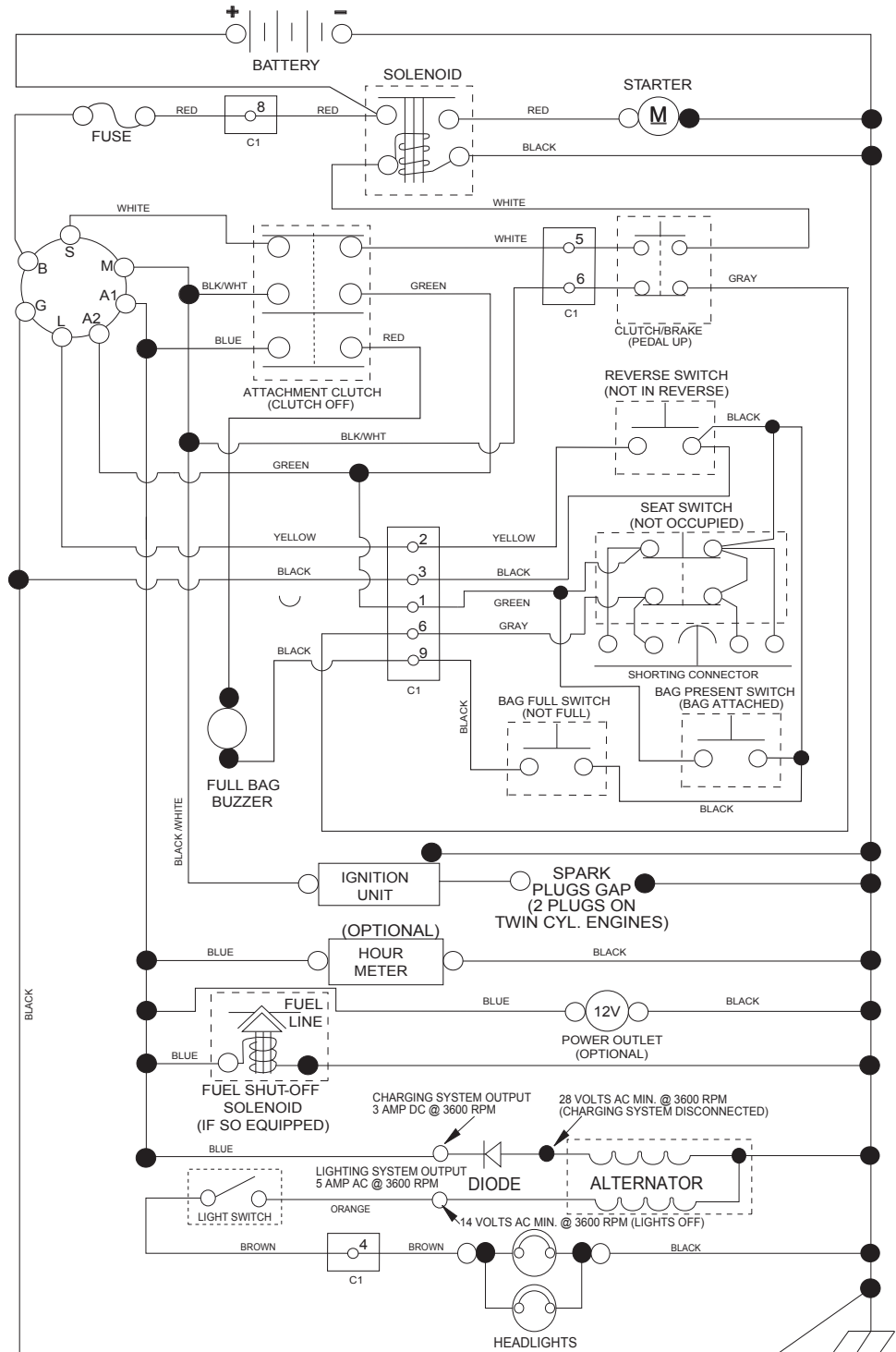

**NOTE**  
 YOUR TRACTOR IS EQUIPPED WITH A SPECIAL ALTERNATOR SYSTEM. THE LIGHTS ARE NOT CONNECTED TO THE BATTERY, BUT HAVE THEIR OWN ELECTRICAL SOURCE. BECAUSE OF THIS, THE BRIGHTNESS OF THE LIGHTS WILL CHANGE WITH ENGINE SPEED. AT IDLE THE LIGHTS WILL DIM. AS THE ENGINE SPEED IS INCREASED, THE LIGHTS WILL BECOME THEIR BRIGHTEST.



IGNITION SWITCH

POSITION	CIRCUIT	"MAKE"
OFF	M+G+A1	
RUN/OVERRIDE	B+A1	
RUN	B+A1	L+A2
START	B + S + A1	



CHASSIS HARNESS CONNECTOR (C1) (MATING SIDE)



DASH HARNESS CONNECTOR (C1) (MATING SIDE)

WIRING INSULATED CLIPS  
 NOTE: IF WIRING INSULATED CLIPS WERE REMOVED FOR SERVICING OF UNIT, THEY SHOULD BE RE-INSTALLED TO PROPERLY SECURE YOUR WIRING.

NON-REMOVABLE CONNECTIONS  
 REMOVABLE CONNECTIONS



**TRACTOR - MODEL NO. M125-97TC (96051014900), PROD. NO. 960 51 01-49  
ELECTRICAL 32**

<b>KEY NO.</b>	<b>PART NO.</b>	<b>DESCRIPTION</b>
1	532 43 71-57	Battery
2	532 44 09-23	Screw Hex Hd Cap M6 x 1.12mm
16	532 17 61-38	Switch Interlock
21	532 40 02-52	Harness Asm Light w/4152J
22	532 00 41-52	Bulb Light #1156
25	581 48 98-01	Cable Battery Red
26	532 17 51-58	Fuse
27	873 51 04-00	Nut Keps Hex 1/4-20 unc
28	581 48 98-02	Cable Ground Black
29	532 40 15-45	Switch Seat
30	532 19 33-50	Switch Ignition
33	532 41 19-35	Key/Chain
34	532 11 07-12	Switch Light
40	532 42 10-02	Harness Ignition Dash
43	582 04 28-01	Solenoid
55	817 06 05-12	Screw 5/16-18 x 3/4
71	581 02 33-01	Harness Chassis
79	532 17 52-42	Socket Asm.
83	532 43 67-74	Nut Square M6 x 1 x 8.5 x 11mm
87	532 42 10-60	Switch Railmount
99	817 00 05-12	Screw 5/16-18 x 3/4
102	581 02 35-01	Harness Jumper
105	532 40 75-68	Switch Reverse
107	532 18 03-79	Switch Full Bagger Indicator
108	532 42 10-62	Switch Snapmount

**NOTE:** All component dimensions given in U.S. inches  
1 inch = 25.4 mm

TRACTOR - MODEL NO. M125-97TC (96051014900), PROD. NO. 960 51 01-49  
CHASSIS AND ENCLOSURES **39**

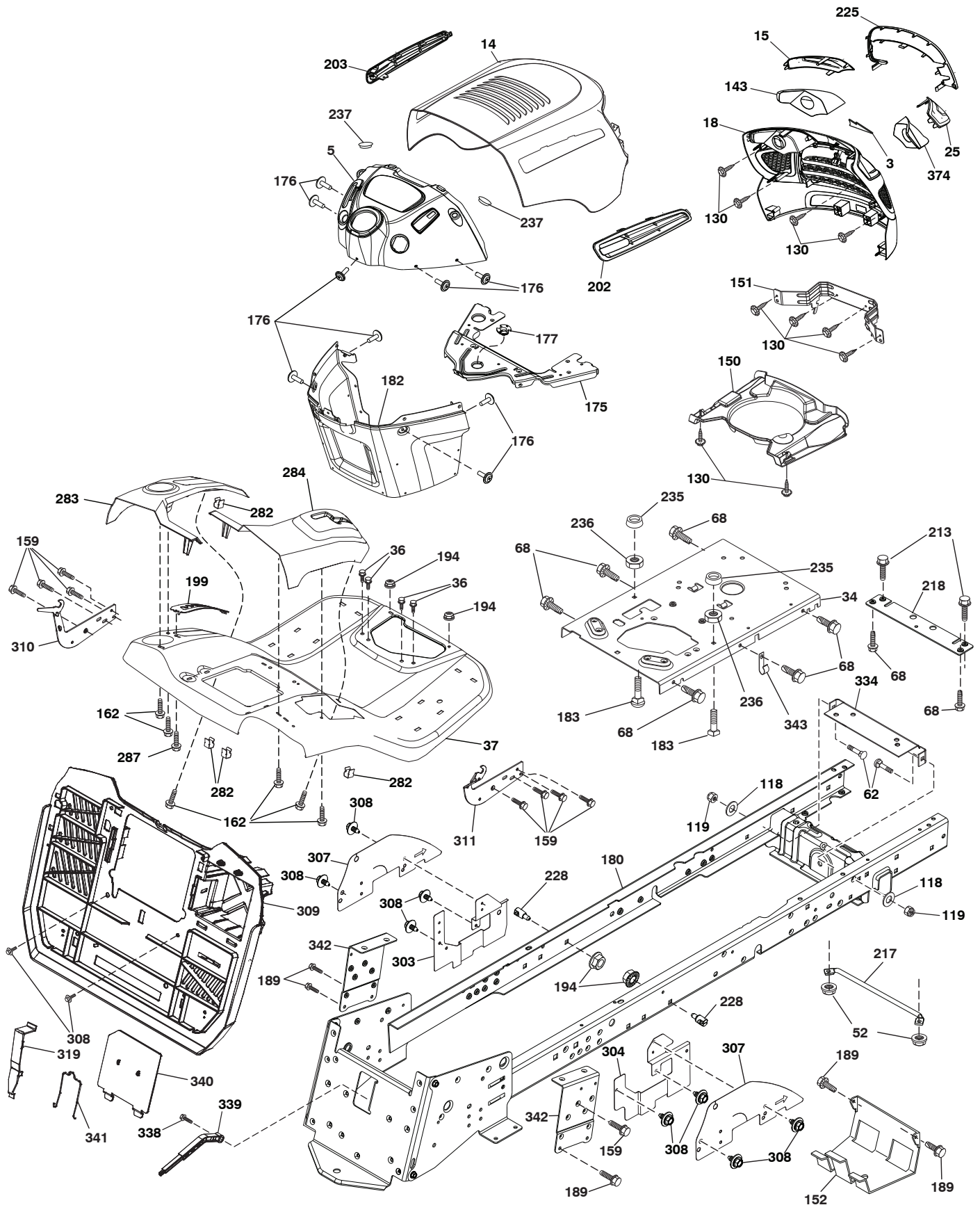

chassis-tex crd\_TEX LT PRED\_15\_r1

**TRACTOR - MODEL NO. M125-97TC (96051014900), PROD. NO. 960 51 01-49  
CHASSIS AND ENCLOSURES **39****

KEY NO.	PART NO.	DESCRIPTION	KEY NO.	PART NO.	DESCRIPTION
3	578 89 71-01	Emblem Mount	213	874 76 05-12	Bolt 5/16-18 x 3/4
5	532 42 57-72	Dash	217	532 40 91-67	Rod Pivot Hood
14	581 56 47-01	Hood	218	532 19 63-95	X-Piece Hood Stop
15	581 05 58-01	Lens LH	225	581 05 62-01	Trim Ring
18	581 05 57-01	Grille	228	532 19 51-61	Stud Fastener
25	581 05 59-01	Lens RH	235	532 40 61-29	Spacer Fender
34	580 91 09-01	Plate Engine	236	873 93 05-00	Nut Lock 5/16-18 unc
36	817 06 05-12	Screw 5/16-18 x 3/4	237	532 40 37-04	Plug Mount Cargo
37	532 44 08-49	Fender	282	532 41 41-10	Clip Retainer
52	873 68 05-00	Nut Crown Lock 5/16	283	532 44 03-61	Console Deck Lift
62	872 11 06-08	Bolt 3/8-16 x 1 Gr. 5	284	532 44 03-60	Console Shift RH
68	817 49 05-08	Screw Thdrol. 5/16-18 x 1/2	287	817 60 04-06	Screw Hex Washhead 1/4-20 x 3/8
118	819 13 13-16	Washer 13/32 x 13/16 x 16 Ga.	303	587 49 31-01	Shield LH
119	873 68 06-00	Nut 3/8-16 unc	304	589 41 27-01	Shield RH
130	532 41 63-58	Screw #10 x 0.750 BOS Thread	307	587 49 45-01	Shield Upper
143	581 05 60-01	Insert Reflective LH	308	532 17 18-77	Bolt 5/16-18 unc x 3/4
150	532 40 02-67	Duct, Air	309	501 18 83-01	Backplate Bagger
151	532 18 75-68	Bracket Pivot Hood	310	532 44 66-36	LH Adjust Hanger
152	532 19 95-35	Shield Browning	311	532 44 66-37	RH Adjust Hanger
159	817 00 06-12	Screw Hexwsh Thdr 3/8-16 x 3/4	319	532 17 46-62	Lever Bagger
162	532 14 24-32	Screw Hex Wsh. Hi-Lo 1/4 x 1/2 unc	334	532 44 25-37	Engine Plate
175	532 19 94-72	Crossmember	338	532 43 66-40	Bolt Shoulder
176	532 40 07-76	Screw 10-24 x 5/8	339	532 43 66-41	Lever Bagger Full
177	532 19 52-28	Bushing Steering	340	532 44 09-31	Door Battery
180	582 74 60-01	Chassis	341	582 06 08-01	Latch Battery Door
182	532 40 71-76	Dash Lower	342	582 82 68-02	Support Fender
183	874 52 05-20	Bolt 5/16-18 x 1-1/4	343	532 44 07-49	Clip
189	817 00 05-12	Screw 5/16-18 x 3/4	374	581 05 60-02	Insert Reflective RH
194	873 90 05-00	Nut Lock Hex Flange 5/16-18			
199	532 41 87-39	Plate Deck Lift			
202	588 98 86-01	Vent Hood RH			
203	588 98 86-02	Vent Hood LH			

**NOTE:** All component dimensions given in U.S. inches  
1 inch = 25.4 mm







**TRACTOR - MODEL NO. M125-97TC (96051014900), PROD. NO. 960 51 01-49  
DRIVE 40**

KEY NO.	PART NO.	DESCRIPTION	KEY NO.	PART NO.	DESCRIPTION
1	-----	Transaxle, Gentrans Fast VATR. (582491201) (Order parts from transaxle manufacturer.)	194	583 87 86-01	Bellcrank Brake
2	532 12 35-83	Key Square .2.0 x .1845/.1865	195	580 45 69-02	Brake Bracket
6	532 12 40-28	Bushing Snap	203	819 11 11-16	Washer 11/32 x 11/16 x 16 Ga.
15	819 13 13-16	Washer 13/32 x 13/16 x 16 Ga.	204	584 99 70-01	Link Pivot Pedal
17	580 32 52-01	Spring Brake	205	532 12 17-48	Washer 25/32 x 1-5/8 x 16 Ga.
29	581 18 74-01	Rod Brake	210	588 92 10-01	Weldment Pedal
33	812 00 00-01	E-Ring. #5133-75	211	532 12 01-83	Bearing Nylon
35	532 40 10-31	Rod Brake Parking. Lt.Tex	214	532 42 12-63	Pedal Forward Pad
37	532 18 89-67	Washer Harden .793 x 1.637 x 060	215	582 53 28-01	Cap Pedal Reverse
42	532 12 48-72	Cover Pedal Blk Round	221	532 40 31-87	Retainer Spring Clip Handle
49	872 11 06-14	Bolt Rdhd 3/8-16 Unc x 1-3/4.Gr 5	222	879 21 20-10	Washer 21/32 x 1-1/4 10 Ga.
51	873 90 06-00	Nut, Hex, Flangelock 3/8-16	263	817 00 06-12	Screw Hxwsh Thdr 3/8-16 x 3/4
52	532 19 43-26	Idler V-Groove Offset	268	532 18 24-02	Guard Muffler
56	532 44 69-91	Belt Drive	275	819 13 16-14	Washer 13/32 x 1 x14 Ga.
64	589 67 14-01	Shaft Asm. Pedal Brake	276	590 63 01-02	Bracket Control Pedal
67	582 58 01-01	Washer Nylon 13/32 x 13/16 x 1.09	277	532 44 85-00	Subasm. Link Rocker Pedal
73	580 83 04-01	Bolt Shoulder Transaxle	280	819 11 10-12	Washer 11/32 x 5/8 x 12 Ga.
90	532 44 36-05	Keeper Belt	296	532 42 04-71	Screw Thdrol 5/16-18 x 3
99	581 28 09-01	Rod Bypass	306	876 02 04-16	Pin Cotter 1/8 x 1
103	873 35 05-00	Nut Hex Jam 5/16-18 UNC	310	817 49 06-08	Screw Thdrol 3/8-16 x 1/2
116	873 90 05-00	Nut, Lock Hex Flange 5/16-18 unc	311	585 07 20-01	Washer Nylon
117	580 38 29-01	Subasm Bellcrank Brake	314	532 44 47-13	Keeper Belt
125	817 00 05-12	Screw 5/16-18 x 3/4 Smgml Tap/Bl	315	817 58 05-20	Screw Thdrol 5/16-18 x 1.25
131	876 02 03-08	Pin Cotter 3/32 x 1/2	319	580 45 74-01	Spacer Transaxle
143	817 49 05-08	Screw Thdrol 5/16-18 x 1/2 Tytt	335	532 19 95-34	Pulley V-Idler
153	532 12 49-61	Retainer Clip	342	580 96 10-02	Keeper Belt Idler
156	580 36 90-01	Bolt Shoulder Brake	347	580 32 51-01	Rod Connecting Brake
159	876 02 04-12	Pin Cotter 1/8 x 3/4	351	532 43 69-98	Bracket Swaybar
160	532 16 94-84	Retainer Clip(M).Dia.290	364	532 44 30-32	Bracket Idler
161	532 10 57-09	Spring Return Clutch 6.75	370	878 12 16-32	Washer Thrust 3/8 x 1 x .032
163	581 18 73-01	Rod Control Pedal	371	580 96 07-02	Bracket Idler
166	532 42 91-64	Nut Push .625	372	581 47 52-01	Arm Control Brake
167	532 40 52-57	Latch Brake Parking	378	584 28 77-01	Nut Push
172	532 44 82-76	Strap Torque LH/RH			
184	532 41 14-84	Handle Parking Brake			
185	872 11 06-22	Bolt Rdhd.3/8-16 Unc x 2-3/4 Gr.5			
186	532 19 43-21	Spacer Retainer			
188	582 21 70-01	Link Clutch Ground Drive Long			
189	532 43 36-11	Bellcrank Groundrive			

**NOTE:** All component dimensions given in U.S. inches  
1 inch = 25.4 mm

**TRACTOR - MODEL NO. M125-97TC (96051014900), PROD. NO. 960 51 01-49  
ENGINE 24**

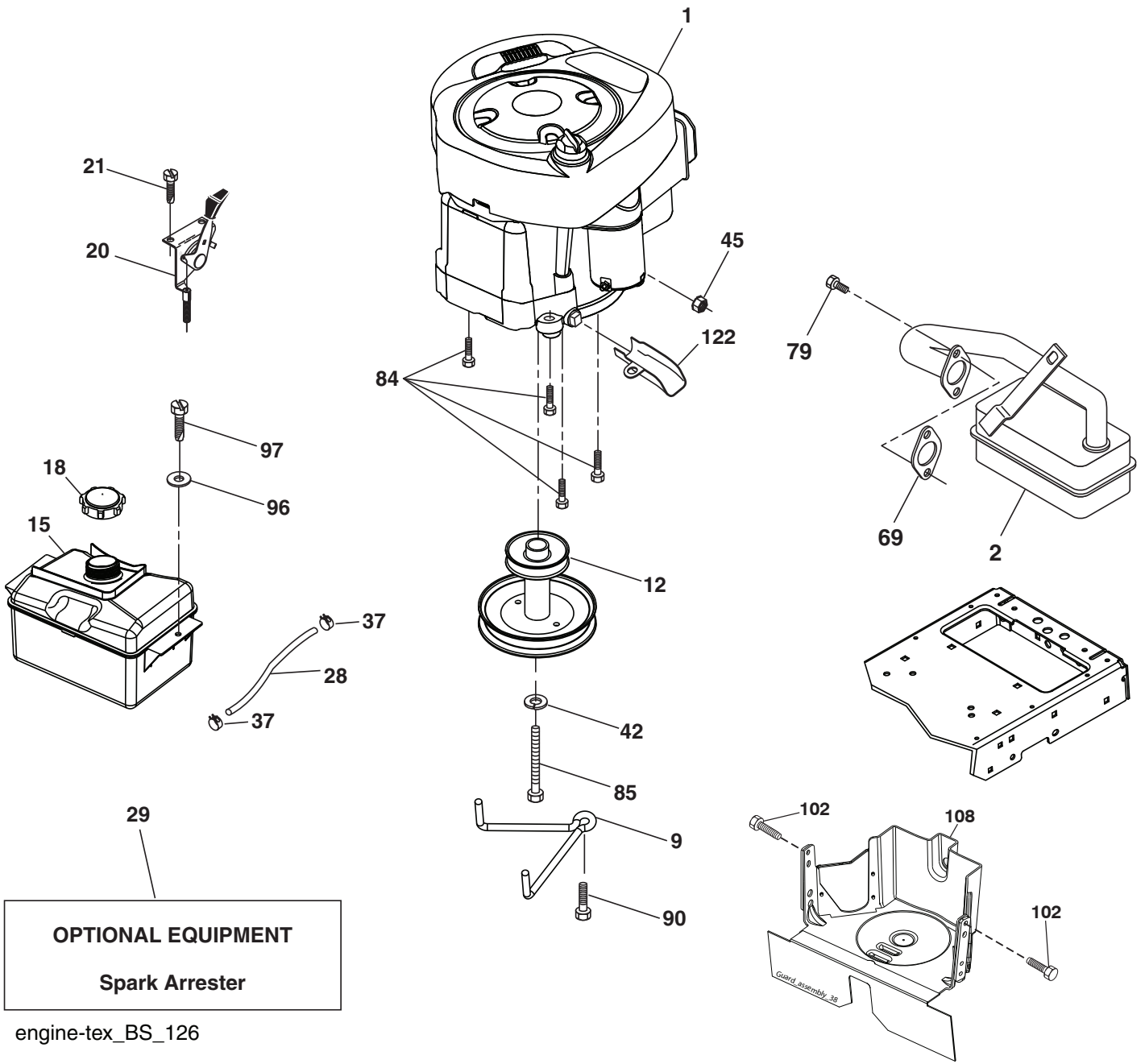

**OPTIONAL EQUIPMENT**  
**Spark Arrester**

engine-tex\_BS\_126

**TRACTOR - MODEL NO. M125-97TC (96051014900), PROD. NO. 960 51 01-49  
ENGINE 24**

<b>KEY NO.</b>	<b>PART NO.</b>	<b>DESCRIPTION</b>
1	— — — — —	Engine Briggs Model 21R707-0115-B1 (501303601) (Order parts from engine manufacturer.)
2	532 17 97-58	Muffler
9	583 84 78-01	Keeper Belt Engine
12	586 47 85-01	Pulley Engine
15	581 28 99-01	Tank Fuel
18	532 43 02-20	Cap Fuel
20	532 18 38-97	Control Throttle/Choke
21	532 41 63-58	Screw #10 x 0.750
28	532 13 70-40	Line Fuel
29	532 13 71-80	Kit Spark Arrester (Flat Scrn)
37	532 12 34-87	Clamp Hose Blk
42	539 99 02-47	Washer SLW STD 7/16
45	873 51-04-00	Nut Keps Hex 1/4-20 unc
69	532 16 52-91	Gasket Muffler
79	532 19 23-34	Screw 5/16-18 x .75
84	817 06 06-20	Screw 3/8-16 x 1-1/4
85	501 60 65-01	Bolt 7/16-20 x 4 x Gr. 5-1.5 THR Hex
90	817 00 06-16	Screw 3/8-16 x 1
96	819 09 14-16	Washer 9/32 x 7/8 x 16 Ga.
97	817 67 04-12	Screw Hexwsh Thdrol 1/4-20 x 3/4
102	817 06 05-16	Screw
108	587 17 95-02	Cover Pulley Eng. w/SHLD
122	532 42 19-22	Extension Drain Oil

**NOTE:** All component dimensions given in U.S. inches  
1 inch = 25.4 mm

**Engine Power Rating Information**

The gross power rating for individual gas engine models is labeled in accordance with SAE (Society of Automotive Engineers) code J1940 (Small Engine Power & Torque Rating Procedure), and rating performance has been obtained and corrected in accordance with SAE J1995 (Revision 2002-05). Torque values are derived at 3060 RPM; horsepower values are derived at 3600 RPM. Actual gross engine power will be lower and is affected by, among other things, ambient operating conditions and engine-to-engine variability. Given both the wide array of products on which engines are placed and the variety of environmental issues applicable to operating the equipment, the gas engine will not develop the rated gross power when used in a given piece of power equipment (actual “on-site” or net power). This difference is due to a variety of factors including, but not limited to, accessories (air cleaner, exhaust, charging, cooling, carburetor, fuel pump, etc.), application limitations, ambient operating conditions (temperature, humidity, altitude), and engine-to-engine variability. Due to manufacturing and capacity limitations, Briggs & Stratton may substitute an engine of higher rated power for this Series engine.



**TRACTOR - MODEL NO. M125-97TC (96051014900), PROD. NO. 960 51 01-49**  
**STEERING ASSEMBLY 41**

<b>KEY NO.</b>	<b>PART NO.</b>	<b>DESCRIPTION</b>
1	532 42 45-51	Wheel, Steering
2	532 41 81-68	Axle Asm.
4	532 40 30-87	Spindle Asm., LH
5	532 40 30-88	Spindle Asm., RH
6	532 12 49-31	Bearing, Race Thrust Harden
7	532 12 17-48	Washer 25/32 x 1-5/8 x 16 Ga.
8	812 00 00-29	Ring, Klip #T5304-75
9	532 12 12-32	Cap, Spindle
13	532 12 17-49	Washer 25/32 x 1-1/4 x 16 Ga.
14	539 99 01-18	Washer, SLW ZD 3/8
15	873 54 06-00	Nut, Crown Lock 3/8-24 unf
16	585 86 92-02	Steering Shaft
19	532 19 47-29	Plate Steering
20	532 40 97-63	Boot, Steering
21	532 18 67-37	Adapter, Wheel Steering
22	585 02 98-02	Bearing
26	532 42 45-53	Insert, Wheel Steering
27	819 21 16-16	Washer 21 x 32 x 1 x 16 Ga.
28	817 00 06-12	Screw 3/8-16 x 3/4
33	539 99 01-87	Washer Lock 5/16
35	532 19 47-32	Gear, Sector Plate
45	819 11 38-12	Washer 11/32 x 2-3/8 x 12 Ga.
53	532 18 89-67	Washer Hardened .793 x 1.637 x .060
58	532 19 47-47	Bolt Shoulder Sector Pivot CFM
59	532 19 47-48	Washer Thrust Sector Steering
60	873 97 10-00	Nut Flange Lock 5/8-11
61	532 19 47-40	Draglink, LH
62	532 19 47-41	Draglink, RH
63	817 00 05-12	Screw 5/16-18 x 3/4
64	532 19 98-49	Retainer Clip Spring Steering
66	871 02 07-48	Bolt Hex Fghd 7/16-14 x 3 Serr
67	532 19 47-37	Bushing PM Front Axle
68	873 90 07-00	Nut Lock Flange 7/16-14 Gr. 5
69	532 19 91-62	Washer 1.5 x .505 x .118
70	585 33 88-01	Bracket Deck Susp. Front
71	532 19 07-52	Shaft Extension Steering
72	532 42 89-82	Bolt Fin Hx 5/16-18 x 4
74	532 12 49-37	Bearing
75	580 68 37-01	Pinion
76	580 68 36-01	Screw Head Sock
122	532 44 49-62	Cap Gear Sector

**NOTE:** All component dimensions given in U.S. inches  
1 inch = 25.4 mm

TRACTOR - MODEL NO. M125-97TC (96051014900), PROD. NO. 960 51 01-49  
MOWER DECK 44

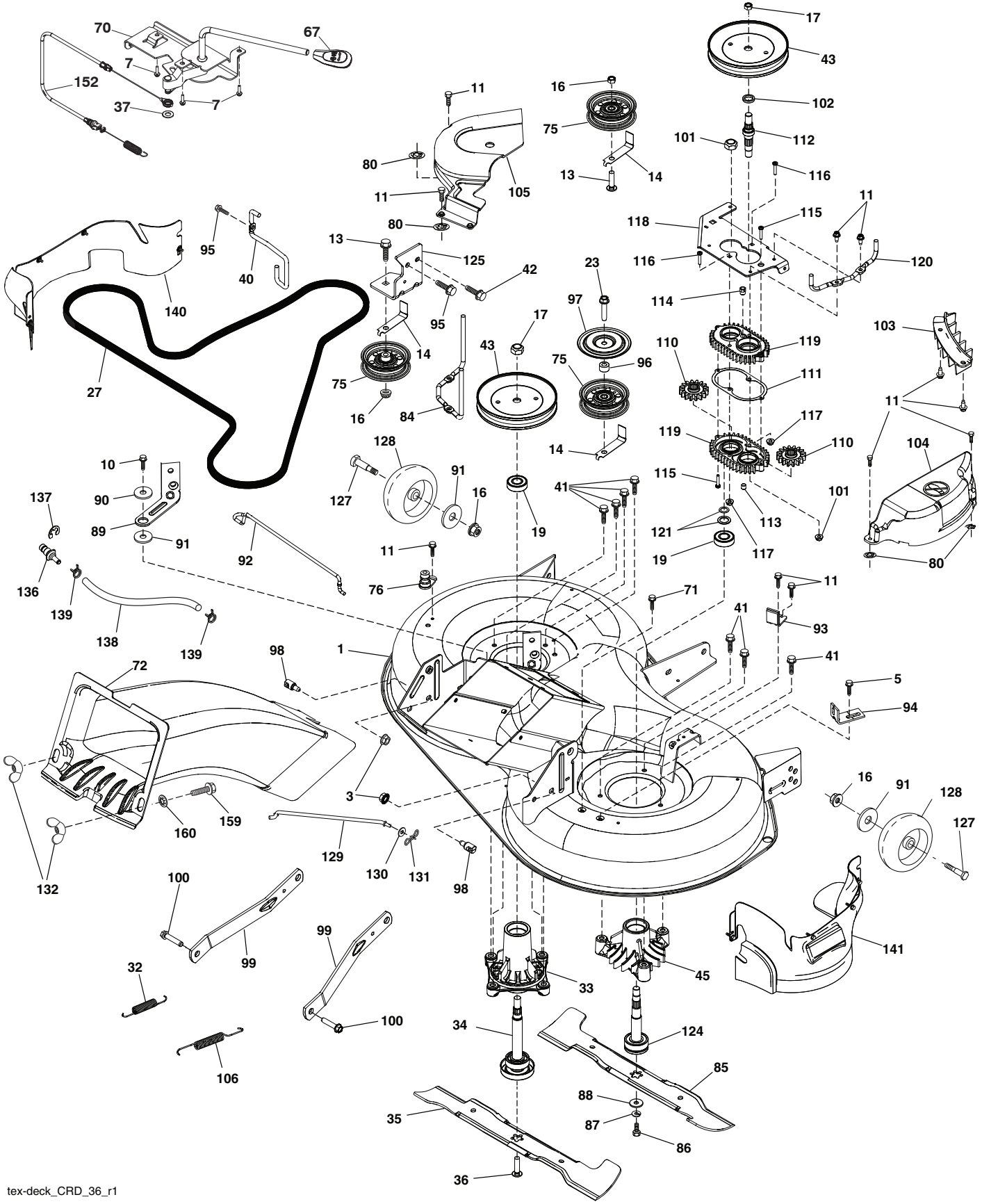

tex-deck\_CRD\_36\_r1



**TRACTOR - MODEL NO. M125-97TC (96051014900), PROD. NO. 960 51 01-49**  
**MOWER DECK 44**

KEY NO.	PART NO.	DESCRIPTION	KEY NO.	PART NO.	DESCRIPTION
1	532 43 69-70	Deck Weldment	105	532 43 87-44	Mandrel Cover LH
3	873 90 05-00	Nut Lock Hex Flange 5/16 - 18	106	532 19 32-16	Spring Brake Return
5	817 00 05-10	Bolt 5/16-18	110	587 93 48-01	Gear Output
7	532 41 63-58	Screw #10 x 0.750 BOS Thread	111	532 43 69-79	Gasket Gearcase
11	532 13 77-29	Screw Thd Roll 1/4 - 20 X 5/8	112	532 44 38-52	Shaft Gearcase Adapter
13	872 11 06-12	Bolt Carr Sh 3/8 - 16 X 1-1/2 Gr. 5	113	532 43 85-33	Plug Oil
14	532 15 60-85	Keeper Belt Idler	114	588 17 05-01	Vent Breather
16	873 90 06-00	Nut Lock FIG 3/8 - 16 unc	115	818 03 10-16	Screw Torx #10-24 x 1
17	532 40 02-34	Nut Flange Lock Top	116	872 11 04-14	Bolt 1/4-20 x 1.75 Gr. 5
19	532 11 04-85	Bearing Ball Mandrel	117	873 90 04-00	Nut Hex Flange 1/4-20 unc
23	817 49 06-28	Screw Thdrol 3/8 - 16 X 1-3/4	118	532 43 69-89	Arm Clutching
10	817 00 06-16	Screw 3/8-16x1 smgml tap	119	532 43 81-66	Gearcase Subasm
27	532 43 97-26	V-Belt Drive	120	532 43 69-91	Keeper Belt RH
32	532 40 18-72	Spring Return Deck	121	532 43 69-85	Washer
33	532 18 72-81	Housing Mandrel 4pt Service	124	532 43 69-86	Non Greasable Mandrel Shaft
34	532 19 28-72	Shaft Asm Mndrl N/Greaseable38	125	532 44 04-20	Bracket Idler Chassis
35	532 42 79-84	Blade Mower LH	127	532 19 34-06	Bolt Shoulder 3/8-16 x 3-5/8 Gr. 5
36	584 30 93-01	Screw Sems 7/16 - 20 x 1 Hx Hd	128	589 52 73-01	Wheel Gauge
37	819 13 13-16	Washer 13/32 x 13/16 x 16 Ga.	129	532 40 48-51	Rod Anti-Sway
40	532 19 72-58	Keeper Belt Engine LH	130	819 13 13-12	Washer 13/32 x 13/16 x 12 Ga.
41	584 95 39-01	Bolt Hex	131	532 19 42-08	Pin Cotter 5/16 Bow Tie Lock
42	817 00 05-12	Screw 5/16-18 x 3/4	132	532 17 88-99	Knob Handle 3/8-16
43	532 19 74-73	Pulley Mandrel	136	532 43 96-39	Washout Port
45	532 13 71-52	Housing Mandrel	137	812 00 00-29	Ring Clip
67	532 40 30-12	Handle Clutch Cable	138	532 44 07-43	Hose
70	532 40 12-46	Clutch Asm Manual LT Pred	139	532 44 07-42	Hose Clamp
71	817 67 06-08	Screw 3/8-16 x 1/2	140	501 57 94-01	LH Guard
72	582 03 56-01	Chute Upper	141	501 57 93-01	RH Guard
75	532 13 14-94	Pulley Idler Flat	152	532 44 04-88	Cable Clutch Manual w/Spring
76	532 43 96-40	Washout Port	159	872 14 06-14	Bolt 3/8-16 unc x 1-3/4
80	532 42 30-62	Pal Nut	160	532 16 89-37	Nut Push
84	532 43 25-20	Keeper Belt LH Mandrel	--	587 25 33-01	MANDREL ASSEMBLY (Includes Housing Assembly (key#33), Shaft Assembly (key#34) and Bearing Only (key#19) - Pulley/ Nut/Washer And Blade Bolt/ Washers Not Included)
85	532 42 79-85	Blade Mower RH			
86	532 18 17-13	Bolt 3/8-24 x 1.50 Gr. 8			
87	539 99 01-18	Washer SLW ZD 3/8			
88	532 14 02-96	Washer Hard			
89	532 43 81-24	Arm Brake 97 LH			
90	532 19 90-92	Spacer Retainer	--	532 44 81-32	Gear Case Kit. Use .75 oz. Shell 460 Oil. (Include Gear Output (key #110), Gasket Gearcase (key #111), Shaft Gearcase (key #112), Plug Oil (key #113), Vent Breather 1/8 NPT (key #114), Screw Torx (key #115), Gearcase Subasm (key #119).
91	819 13 20-12	Washer 13/32 x 1-1/4 x 12 Ga.			
92	532 43 69-93	Rod Brake Assembly			
93	532 43 81-25	Arm Brake RH			
94	532 19 72-50	Bracket Clutch Cable			
95	817 00 06-12	Screw 3/8-16 x 3/4			
96	532 40 02-71	Spacer			
97	532 18 20-61	Shield Idler Mower			
98	532 19 51-61	Stud Fastener			
99	532 19 51-86	Arm Suspension Mower Rear	--	532 44 86-41	Replacement Mower Complete
100	532 19 65-39	Bolt Shoulder			
101	873 68 09-00	Nut Crownlock 9/16 - 18 unc			
102	532 40 25-11	Spacer Bearing Swing Plate			
103	532 43 69-92	Guard Front Vent			
104	532 43 89-68	Mandrel Cover RH			

**NOTE:** All component dimensions given in U.S. inches  
1 inch = 25.4 mm



**TRACTOR - MODEL NO. M125-97TC (96051014900), PROD. NO. 960 51 01-49**  
**MOWER LIFT 45**

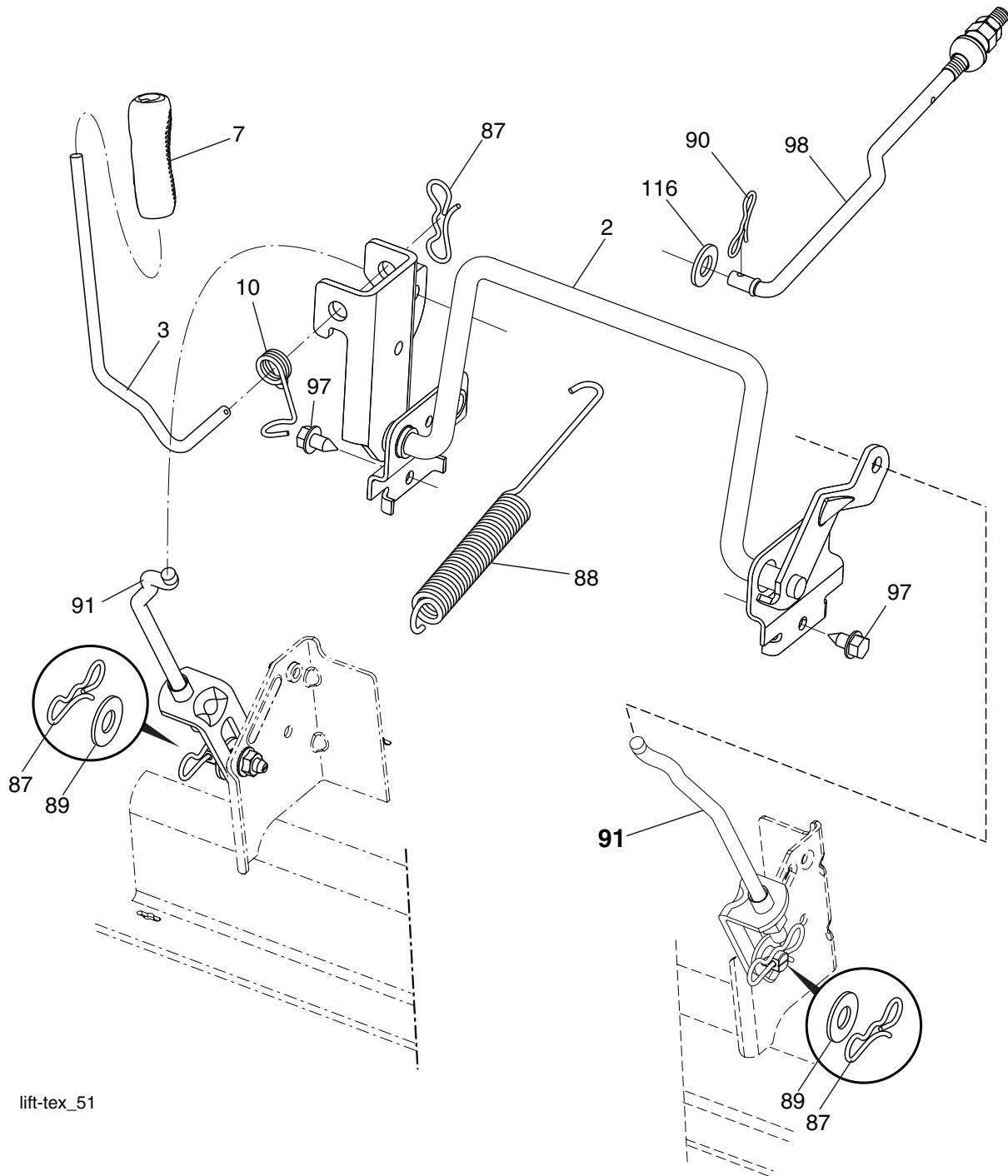

lift-tex\_51

KEY NO.	PART NO.	DESCRIPTION
2	532 43 69-96	Deck Lift
3	532 19 52-31	Lever Asm., Lift RH
7	580 96 23-01	Grip, Lever
10	532 19 63-14	Spring Torsion
87	532 19 42-09	Pin Cotter 7/16 Bow Tie Lock
88	532 43 69-95	Spring Lift Assist
89	819 19 19-12	Washer 17/32 x 1-3/16 x 12 Ga.
90	532 19 42-08	Pin Cotter 5/16 Bow Tie Lock

KEY NO.	PART NO.	DESCRIPTION
91	532 19 51-81	Link Lift Susp Mower Rear
97	817 49 06-08	Screw 3/8-16 x 1/2
98	532 42 05-25	Link Lift Susp. Front Mower
116	819 15 15-16	Washer 15/32 x 15/16 x 16 Ga.

**NOTE:** All component dimensions given in U.S. inches  
 1 inch = 25.4 mm

**TRACTOR - MODEL NO. M125-97TC (96051014900), PROD. NO. 960 51 01-49**  
**SEAT ASSEMBLY 42**

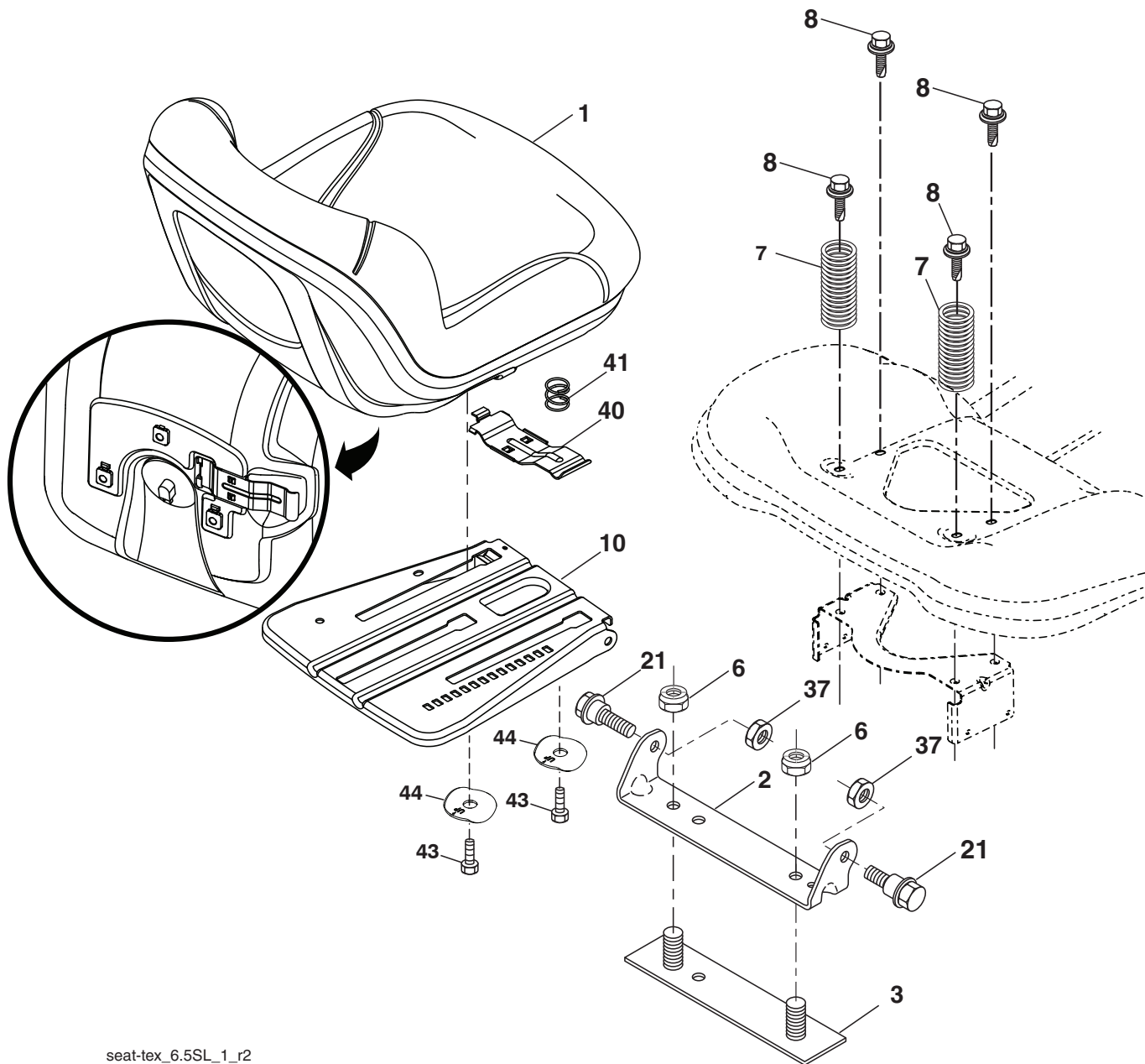

seat-tex\_6.5SL\_1\_r2

KEY NO.	PART NO.	DESCRIPTION
1	581 46 20-01	Seat
2	532 18 01-66	Bracket Pnt Pivot Fender
3	532 14 06-75	Strap
6	873 80 06-00	Nut Lock Hex w/Ins 3/8-16
7	589 48 35-01	Spring Seat Cprsn 2 250 Blk Zi
8	532 17 18-77	Bolt 5/16-18 unc x 3/4
10	587 23 20-02	Pan Pnt Seat
21	587 90 78-01	Bolt Shoulder 5/16-18 x 5/8

KEY NO.	PART NO.	DESCRIPTION
37	873 80 05-00	Nut Hex Lock w/Ins 5/16-18
40	532 19 76-61	Handle Slide
41	532 19 82-00	Spring Latch
43	874 76 06-12	Bolt 3/8-16 unc x 3/4
44	501 05 18-01	Washer Winged 3/8 ID 1.5 OD

**NOTE:** All component dimensions given in U.S. inches  
 1 inch = 25.4 mm

TRACTOR - MODEL NO. M125-97TC (96051014900), PROD. NO. 960 51 01-49  
BAGGER **46**

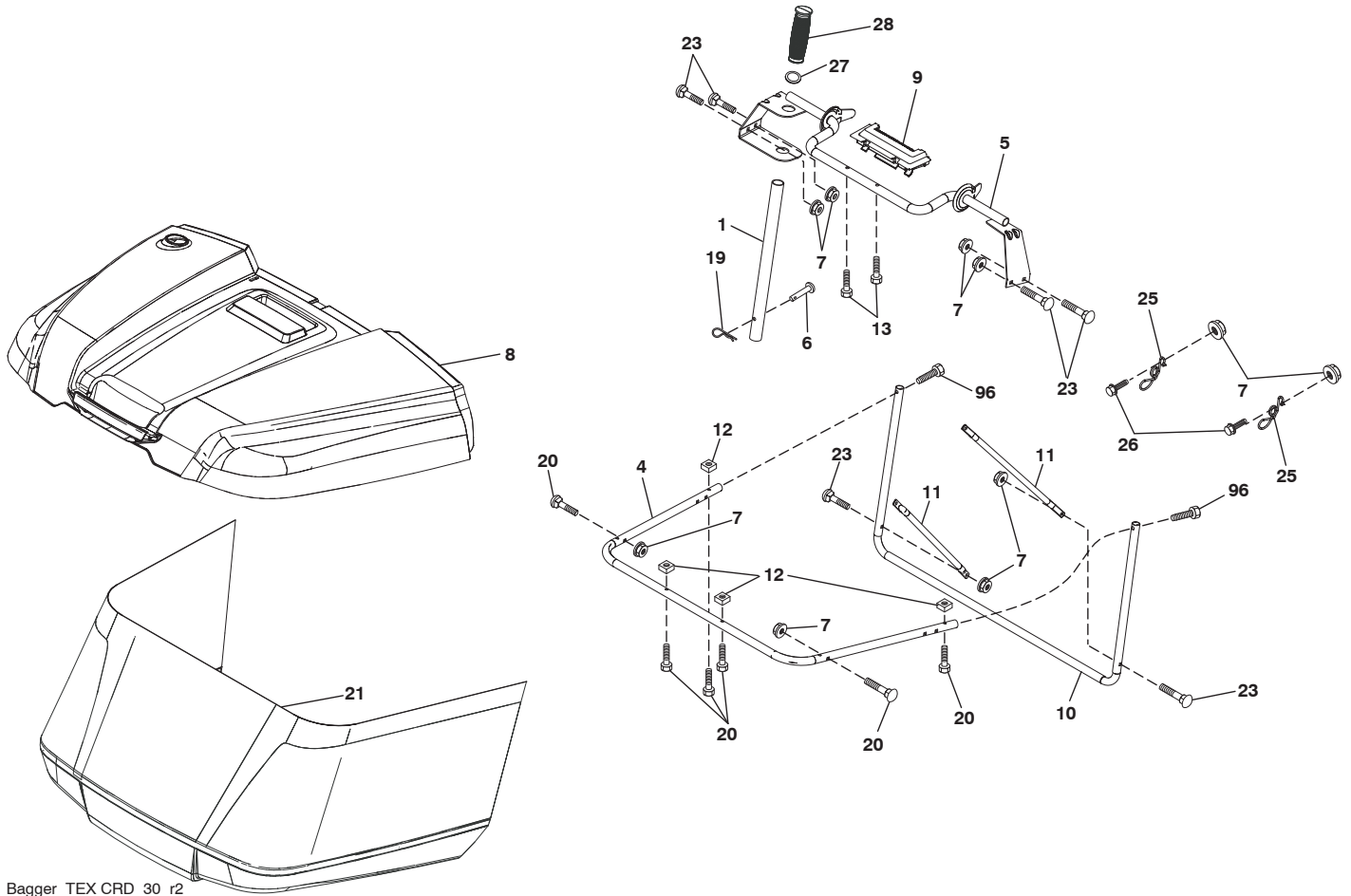

Bagger\_TEX CRD\_30\_r2

**TRACTOR - MODEL NO. M125-97TC (96051014900), PROD. NO. 960 51 01-49  
BAGGER 46**

<b>KEY NO.</b>	<b>PART NO.</b>	<b>DESCRIPTION</b>
1	532 42 86-10	Tube Handle Bagger
4	579 78 54-01	Frame Asm Bagger Top
5	532 41 76-32	Frame Asm Top Bagger
6	532 12 68-75	Rivet Drilled
7	873 90 04-00	Nut Hex Flange 1/4-20 unc
8	532 42 59-54	Cover Bagger
9	532 41 76-29	Insert Handle Bagger
10	532 43 67-70	Frame Front
11	532 43 67-71	Tubing Brace Bagger
12	532 42 17-93	Nut Square 1/4
13	532 42 17-80	Screw 1/4 x 1.150
19	532 19 42-08	Cotter Pin 5/16 Bow Tie
20	585 36 88-01	Screw Hex Cap 1/4-20 x 1.375
21	581 33 70-01	Bag Asm
23	872 04 04-10	Bolt Carr. 1/4-20
25	532 42 16-14	Spring Latch
26	817 49 04-12	Screw 1/4-20
27	532 42 12-62	Grommet Rubber
28	532 16 57-87	Grip Handle Black
96	501 40 66-01	Screw Hex Cap 1/4-20 x 1.500

**NOTE:** All component dimensions given in U.S. inches  
1 inch = 25.4 mm

