

ILLUSTRATED PARTS LIST

MODEL NO. 96041033902

CUSTOMER CATALOG NO. M200-117T

PRODUCT NO. 960 41 03-39

TRACTOR - - MODEL NO. M200-117T (96041033902), PRODUCT NO. 960 41 03-39
DECALS 27

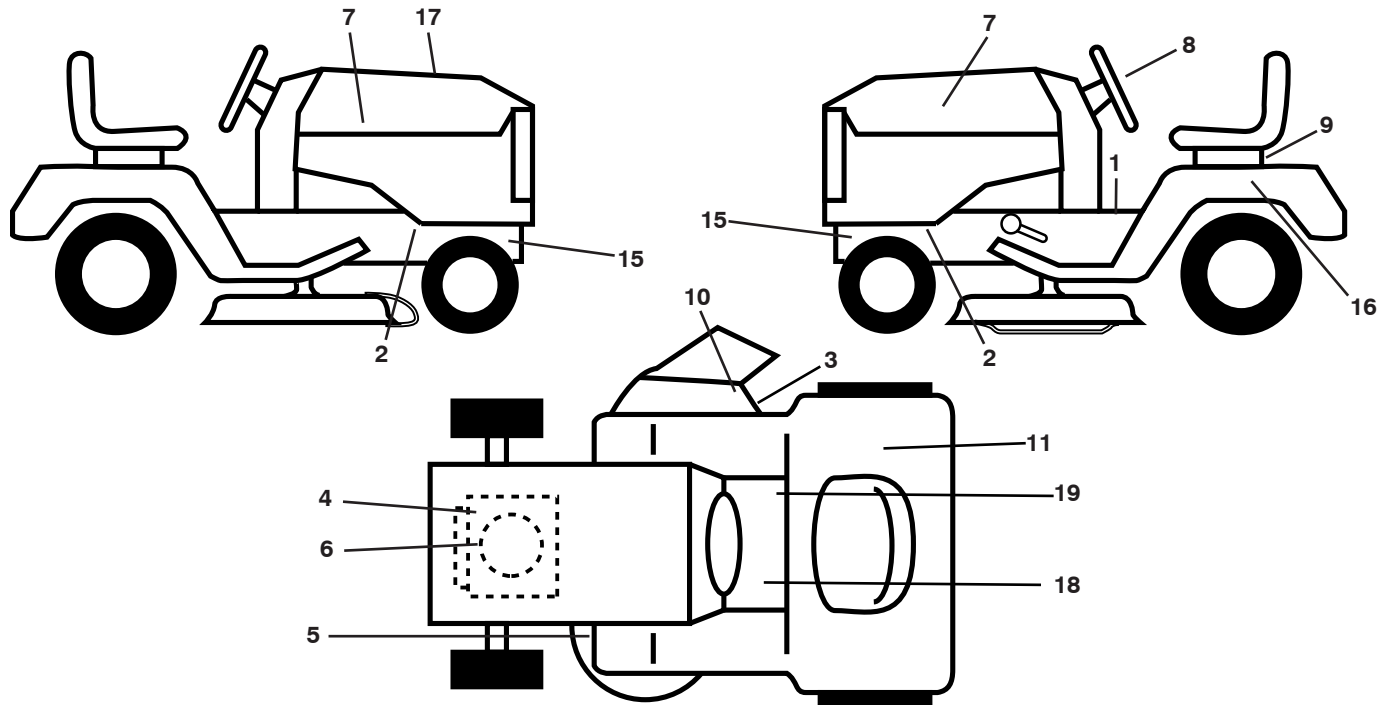

KEY NO.	PART NO.	DESCRIPTION
1	581 57 81-01	Decal, Read Manual
2	581 57 98-01	Decal, Warning Service Fire
3	581 57 92-01	Decal, Warning
4	581 57 97-01	Decal, Warning Engine
5	581 58 00-01	Decal, V-Belt Sch.
6	581 25 90-01	Decal, Eng.
7	581 09 12-01	Decal, Hood LH/RH
8	501 49 43-01	Decal, Steering Wheel
9	532 14 50-05	Decal, Battery Dnge/Poi
10	584 90 46-01	Decal, Deck/Deflect. Warning
11	588 04 97-01	Decal, Decibal 100DB
15	581 57 96-01	Decal, Hot Muffler

KEY NO.	PART NO.	DESCRIPTION
16	581 95 30-01	Decal, Fender
17	581 59 21-01	Decal, Replacement
18	581 72 40-01	Decal, Clutch/Brake
19	581 57 80-01	Decal, Saddle Brake Parking
--	581 72 48-01	Decal, Bypass
--	581 72 46-01	Decal, Drawbar
--	532 40 95-05	Pad, Footrest, LH
--	532 40 95-07	Pad, Footpedal
--	115 81 16-40	Manual, Operator's Euro
--	115 81 16-50	Manual, Operator's Scan
--	115 81 18-20	Manual, Operator's EBloc
--	115 81 19-30	Manual, Operator's Baltic

WHEELS AND TIRES

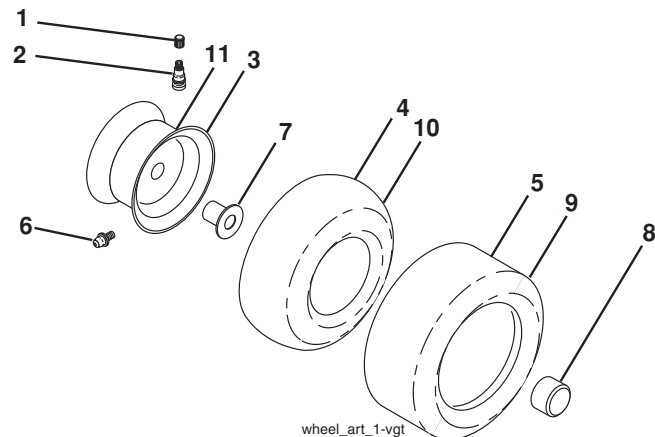

KEY NO.	PART NO.	DESCRIPTION
1	532 05 91-92	Cap, Valve, Tire
2	532 06 51-39	Stem, Valve
3	532 12 51-21	Rim Assembly, Front
4	532 05 99-04	Tube, Front (Service Item Only)
5	532 10 62-22	Tire, Front 15 x 6-6
6	532 12 49-57	Fitting, Grease (Front Wheel Only)
7	532 12 49-59	Bearing, Flange (Front Wheel Only)
8	532 19 32-68	Cap, Axle
9	532 13 84-68	Tire, Rear 20 x 8-8
10	532 12 49-26	Tube, Rear (Service Item Only)
11	532 12 51-22	Rim Assembly, Rear
--	532 14 43-34	Sealant, Tire (10 oz. Tube)

NOTE: All component dimensions given in U.S. inches
 1 inch = 25.4 mm

TRACTOR - - MODEL NO. M200-117T (96041033902), PRODUCT NO. 960 41 03-39

SCHEMATIC **38**

SCH13

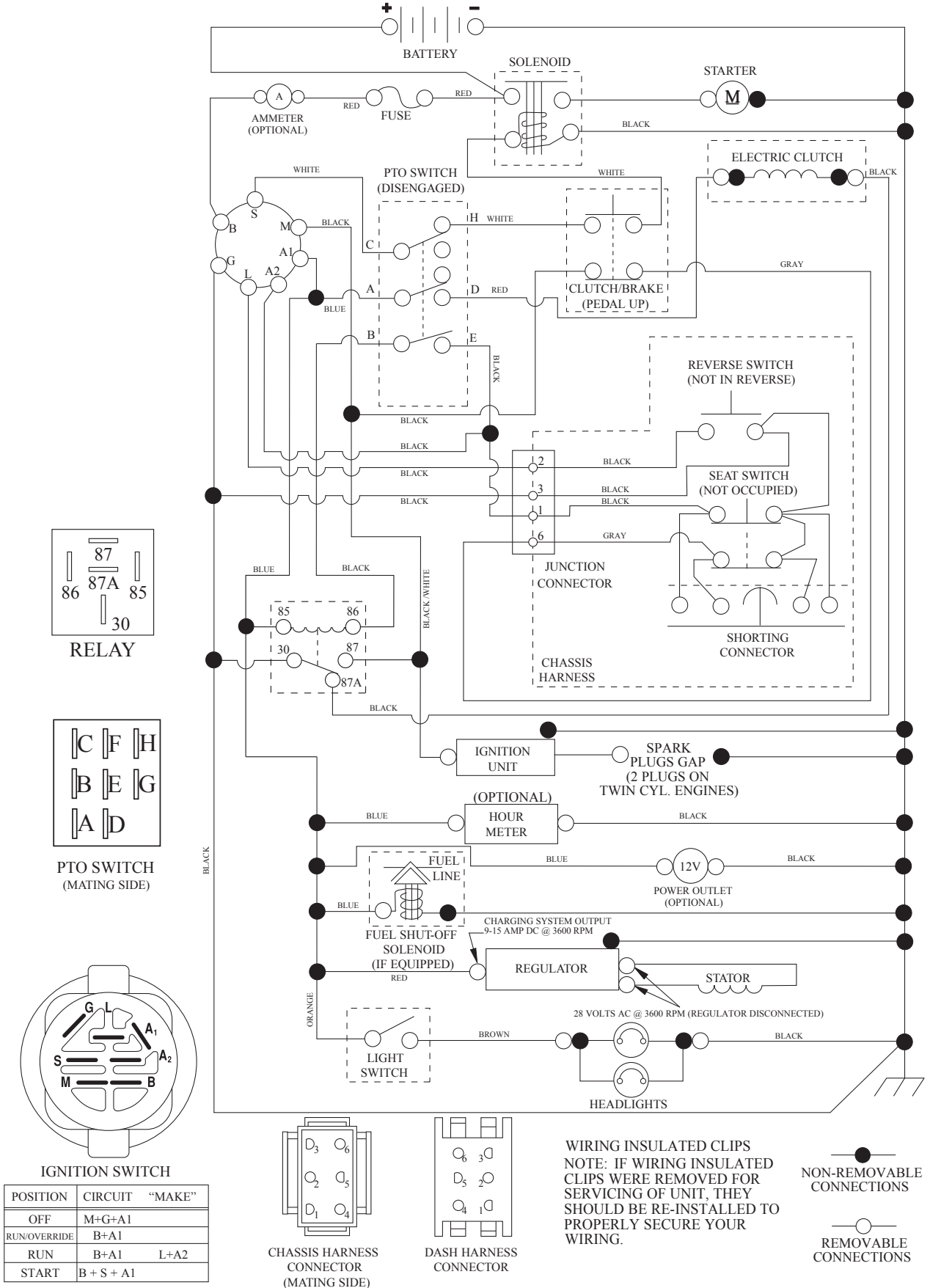

TRACTOR - - MODEL NO. M200-117T (96041033902), PRODUCT NO. 960 41 03-39
ELECTRICAL 32

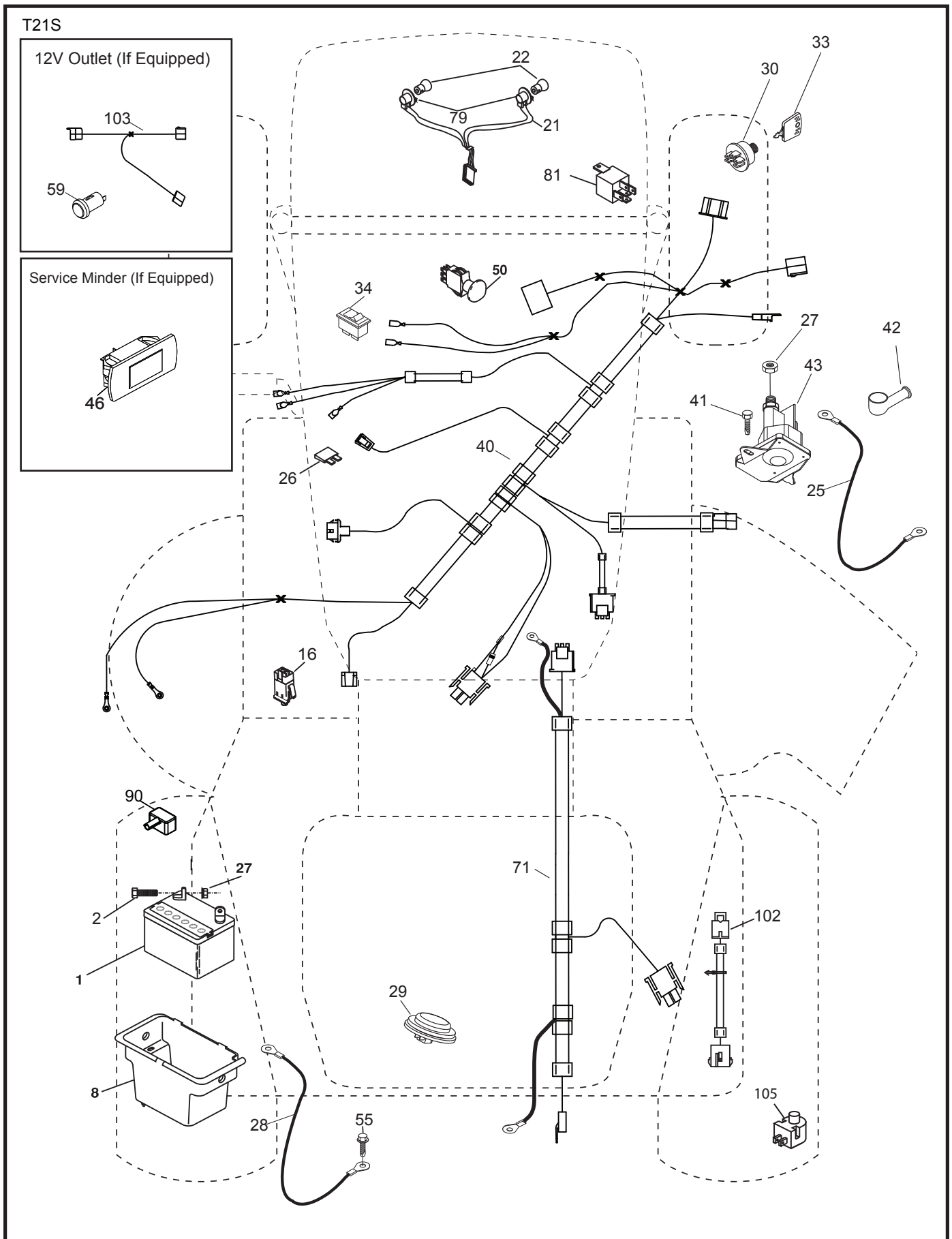

**TRACTOR - - MODEL NO. M200-117T (96041033902), PRODUCT NO. 960 41 03-39
ELECTRICAL 32**

KEY NO.	PART NO.	DESCRIPTION
1	532 16 34-65	Battery
2	874 76 04-12	Bolt Hex Head 1/4-20 x 3/4
8	532 19 32-28	Box Battery
16	532 17 61-38	Switch Interlock Push-In
21	532 40 02-52	Harness Socket Light w/4152J
22	532 00 41-52	Bulb Light
25	585 55 55-01	Cable Starter
26	532 17 51-58	Fuse
27	873 51 04-00	Nut Keps Hex 1/4-20 unc
28	532 41 65-88	Cable,Ground
29	532 40 15-45	Switch, Seat
30	532 19 33-50	Switch, Ign
33	532 41 19-35	Key/Chain
34	532 11 07-12	Switch Light/Reset
40	501 13 32-01	Harness Ign. Dash
41	817 72 04-08	Screw Thd Cut 1/4-20 x 1/2
42	532 13 15-63	Cover Terminal
43	532 19 25-07	Solenoid
50	532 17 46-51	Switch PTO
55	817 06 05-12	Screw Thdrol 5/16-18 x 3/4 TYTT
71	532 44 15-44	Harness Chassis
79	532 17 52-42	Socket Asm
81	532 40 96-15	Relay Harness
90	532 43 53-95	Cover Terminal
102	581 02 34-01	Harness Pigtail
105	532 40 75-68	Switch Reverse

NOTE: All component dimensions given in U.S. inches
1 inch = 25.4 mm

TRACTOR -- MODEL NO. M200-117T (96041033902), PRODUCT NO. 960 41 03-39
CHASSIS AND ENCLOSURES 39

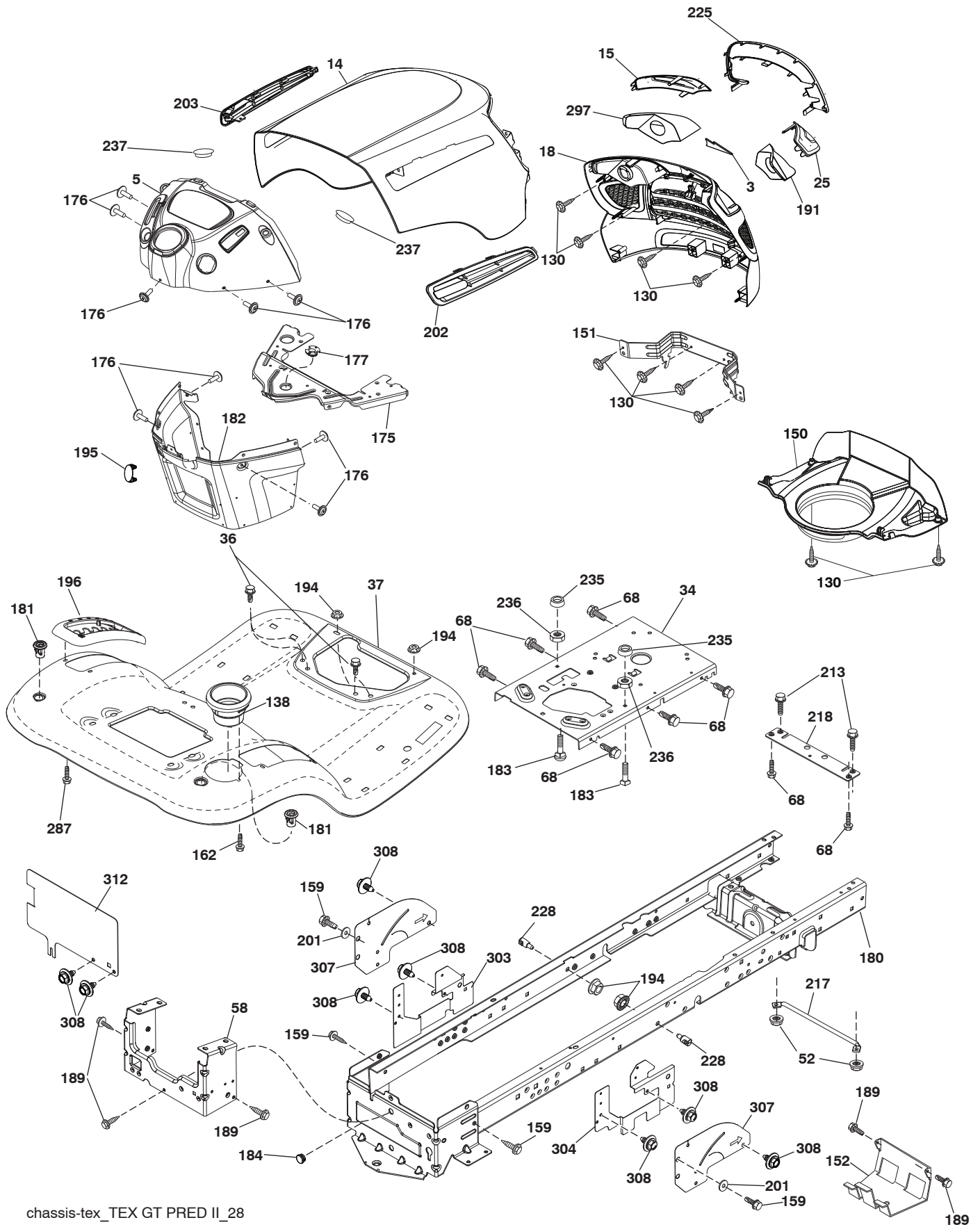

chassis-tex_TEX GT PRED II_28

**TRACTOR - - MODEL NO. M200-117T (96041033902), PRODUCT NO. 960 41 03-39
CHASSIS AND ENCLOSURES 39**

KEY NO.	PART NO.	DESCRIPTION	KEY NO.	PART NO.	DESCRIPTION
3	578 89 71-01	Emblem Mount	195	532 40 41-37	Plug Hole Dash Lower
5	532 42 82-71	Dash	196	532 41 45-81	Console Asm. Deck Lift
14	532 44 80-42	Hood	201	819 13 20-16	Washer 13/32 x 1-1/4 x 16 Ga.
15	581 10 31-01	Lens LH	202	581 85 91-01	Vent Hood RH
18	581 10 29-01	Grille	203	581 85 92-01	Vent Hood LH
25	581 10 30-01	Lens RH	213	874 76 05-12	Bolt Hex Hd. 5/16-18 unc x 3/4
34	580 91 08-01	Plate Engine	217	532 40 91-67	Rod Pivot Chassis
36	817 06 05-12	Screw 5/16-18 x 3/4	218	532 19 63-95	X-Piece Hood Stop
37	532 42 07-96	Fender	225	581 10 32-01	Trim Ring
52	873 68 05-00	Nut lock 5/16-18	228	532 19 51-61	Stud Fastener
58	532 41 22-80	Drawbar, Upper 2 Pc.	235	532 40 61-29	Spacer Fender
68	817 49 05-08	Screw Thdrol. 5/16-18 x 1/2	236	873 93 05-00	Nut center Lock 5/16-18
130	532 41 63-58	Screw #10 x 0.750	237	532 40 37-04	Plug Mount Cargo
138	532 40 97-30	Cupholder	287	817 60 04-06	Screw 1/4-20 x 3/8
150	584 86 29-01	Duct Heat Hood	297	581 22 36-01	Reflector Insert LH
151	532 44 54-94	Bracket Pivot	303	587 49 34-02	Shield Chassis French LH
152	532 19 95-35	Shield Browning	304	587 86 51-02	Shield Chassis French RH
159	817 00 06-12	Screw Hexwsh Thdr 3/8-16 x 3/4	305	872 11 06-06	Bolt RDHD 3/8-16 x 3/4
162	532 14 24-32	Screw Hex Wsh. Hi-Lo 1/4 x 1/2	307	587 49 46-01	Shield Upper Pedal
175	532 19 63-04	Crossmember	308	532 17 18-77	Bolt 5/16-18 unc x 3/4
176	532 40 07-76	Screw 10-24 x 5/8 Wshd. Qdrx.	312	587 49 30-02	Shield Drawbar
177	532 19 52-28	Bushing Steering	--	532 44 11-26	Plug Dash Service Minder
180	532 41 50-63	Chassis	--	532 40 09-44	Bumper
181	532 40 47-96	Bushing Mtg. Fender Crgo.			
182	586 73 86-02	Dash Lower			
183	874 52 05-20	Bolt 5/16-18 x 1-1/4			
184	587 55 41-01	Plug			
189	817 00 05-12	Screw 5/16-18 x 3/4			
191	581 22 35-01	Insert Reflector RH			
194	873 90 05-00	Nut Lock Hex Flange 5/16-18			

NOTE: All component dimensions given in U.S. inches
1 inch = 25.4 mm

TRACTOR -- MODEL NO. M200-117T (96041033902), PRODUCT NO. 960 41 03-39
DRIVE **40**

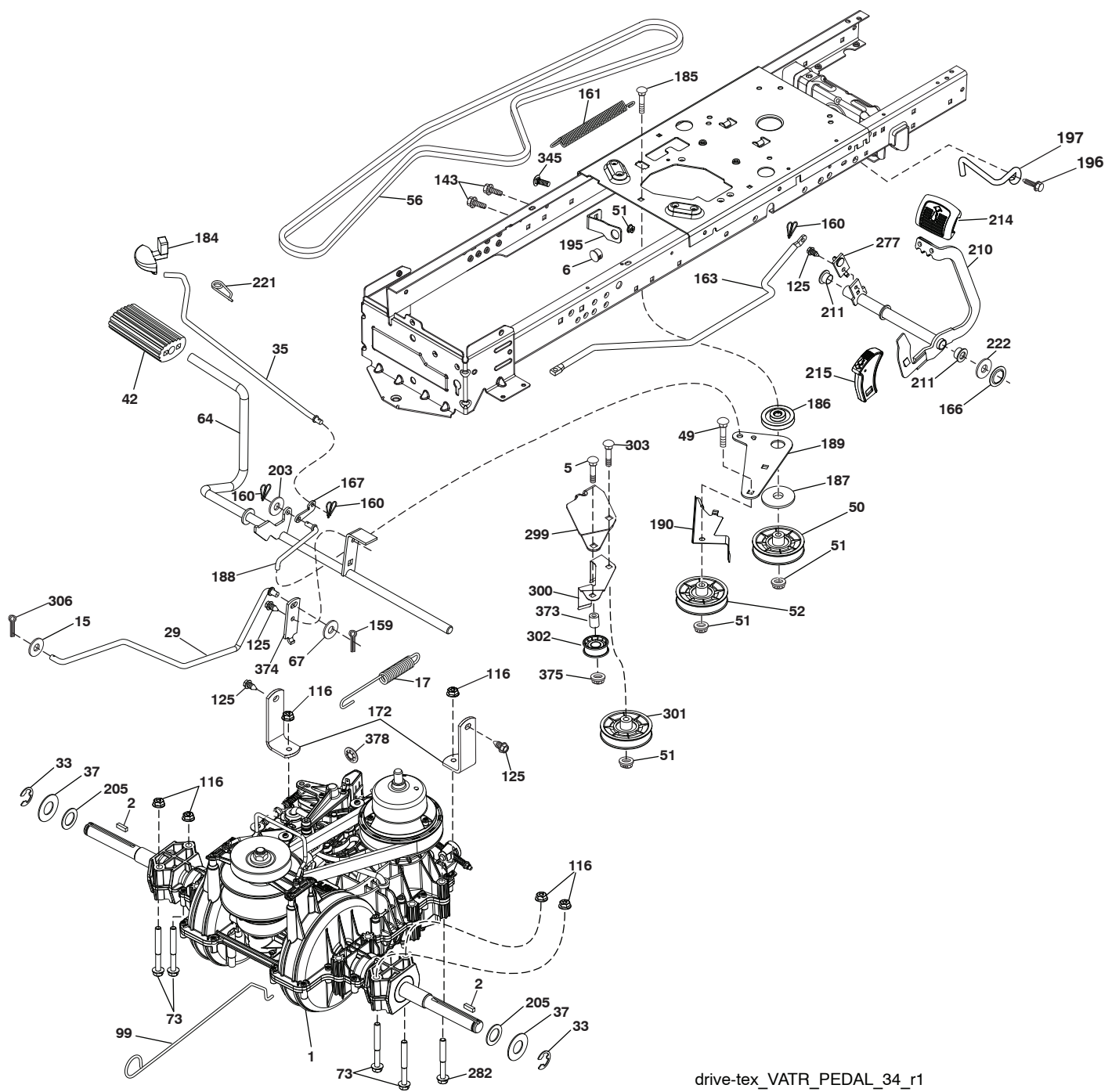

drive-tex_VATR_PEDAL_34_r1

**TRACTOR - - MODEL NO. M200-117T (96041033902), PRODUCT NO. 960 41 03-39
DRIVE **40****

KEY NO.	PART NO.	DESCRIPTION	KEY NO.	PART NO.	DESCRIPTION
1	---	Transaxle, Variator SD Pedal (580486201) (Order parts from transaxle manufacturer.)	187	819 13 32-10	Washer 13/32 x 2 x 10 ga
2	532 12 35-83	Key Square	188	582 21 70-01	Link Clutch Ground Drive Long
5	874 76 06-36	Bolt 3/8-16 x 2-1/4	189	532 19 43-17	Bellcrank Ground Drive
6	532 12 40-28	Bushing Snap	190	532 19 43-18	Keeper. Bellcrank
15	819 13 13-16	Washer 13/32 x 13/16 x 16 Ga.	195	581 50 46-01	Bracket Brake
17	501 48 71-01	Spring, Brake	196	817 00 06-16	Screw 3/8-16 x 1
29	584 82 31-01	Rod, Brake	197	585 65 86-01	Link Clutch Anti-Rotation
33	812 00 00-01	Ring E	203	819 11 11-16	Washer 11/32 x 11/16 x 16 Ga.
35	583 86 45-01	Rod, Brake, Park	205	532 12 17-48	Washer 25/32 x 1-5/8 16 Ga.
37	532 18 89-67	Washer .793 x 1.637 x 060	210	588 92 10-01	Rocker Asm. Pedal
42	532 12 48-72	Cover, Foot Pedal	214	532 42 12-63	Pedal Forward
49	872 11 06-14	Bolt 3/8-16 unc	215	532 44 82-54	Pad Pedal Reverse
50	532 19 43-27	Idler Flat	211	532 12 01-83	Bearing Nylon
51	873 90 06-00	Nut Lock	221	532 40 31-87	Retainer Spring
52	532 19 43-26	Idler V-Groove	222	879 21 20-10	Washer Flat
56	581 60 38-01	V-Belt, Drive	277	532 44 85-00	Subasm. Link Rocker Pedal
64	532 44 83-53	Subasm. Shaft Pedal Brake	282	874 49 05-48	Screw Thdrol 5/16-18 x 3
67	582 58 01-01	Washer Nylon 13/32 x 13/16 x .109	299	532 41 56-83	Bracket Mount
73	874 49 05-44	Bolt Hex 5/16-18 x 3.75	300	532 41 56-81	Keeper Idler
99	532 43 59-35	Rod Bypass	301	532 41 56-80	Pulley Idler Groove
116	873 90 05-00	Nut Lock Hex Flange 5/16-18	302	581 42 05-01	Puller Idler Flat
125	817 00 05-12	Screw 5/16-18 x 3/4	303	872 11 06-18	Bolt
143	817 49 05-08	Screw Thdrol 5/16-18 x 1/2 TYTT	306	876 02 04-16	Pin Cotter 1/8 x 1
159	876 02 04-12	Pin Cotter 1/8 x 3/4	345	872 11 06-06	Bolt 3/8-16 unc
160	532 16 94-84	Retainer Clip	373	581 46 18-01	Spacer Idler
161	532 10 57-09	Spring, Return, Clutch	374	581 47 52-01	Arm Control Brake
163	587 84 79-01	Rod Control	375	873 68 06-00	Nut Crownlock 3/8-16 unc.
166	532 42 91-64	Nut Push .625	378	584 28 77-01	Nut Push 8 mm
167	532 40 52-57	Latch Brake Parking			
172	583 97 42-01	Strap Torque			
184	587 65 37-01	Handle Park Brk.			
185	872 11 06-22	Bolt 3/8-16 unc x 2-3/4			
186	532 19 43-21	Spacer Retainer			

NOTE: All component dimensions given in U.S. inches
1 inch = 25.4 mm

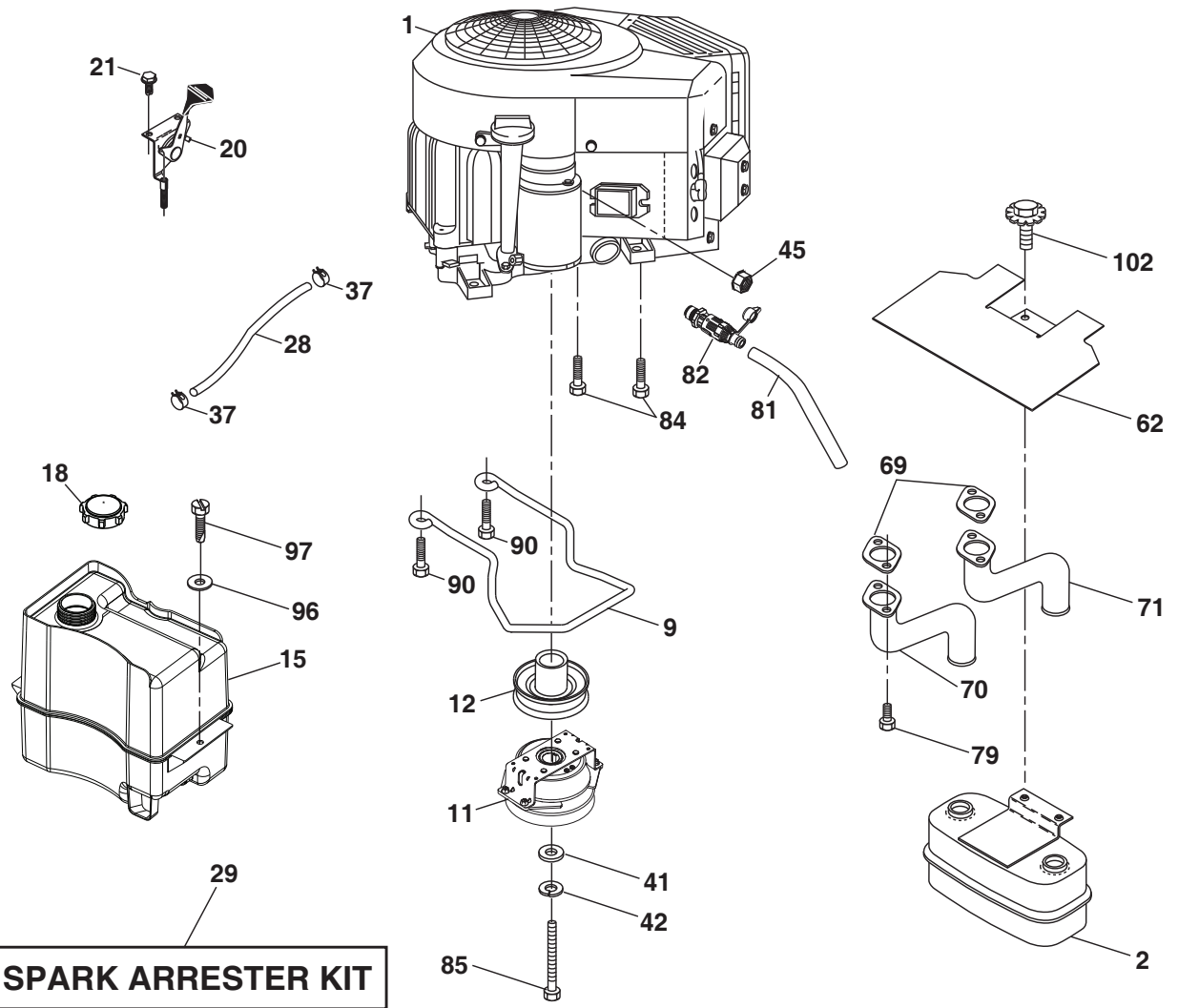

SPARK ARRESTER KIT

engine-tex_bs-2cyl_156

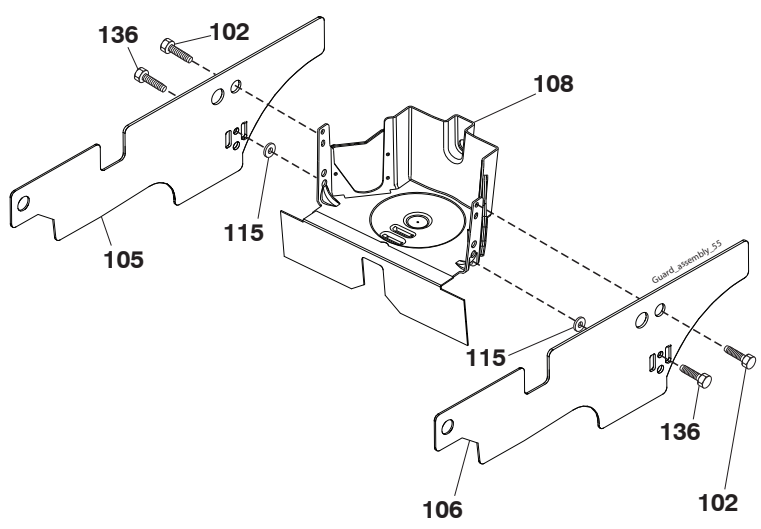

**TRACTOR - - MODEL NO. M200-117T (96041033902), PRODUCT NO. 960 41 03-39
ENGINE 24**

KEY NO.	PART NO.	DESCRIPTION
1	- - - - -	Engine Briggs Model No. 40R777-0003-B1 (585767001) (Order parts from engine manufacturer.)
2	532 14 97-23	Muffler
9	501 83 26-01	Keeper Belt Engine
11	587 24 16-01	Clutch Electric
12	532 40 50-97	Pulley Engine
15	581 29 01-01	Tank Fuel
18	532 43 02-20	Cap Asm
20	532 42 35-02	Control Throttle
21	532 41 63-58	Screw #10 x 0.750 BOS Thread
28	532 13 70-40	Fuel Line
29	532 13 71-80	Spark Arrester Kit
37	532 12 34-87	Clamp Hose
41	532 12 61-97	Washer 1-1/2 OD x 15/32 ID x .250
42	810 04 07-00	Washer Lock 7/16
45	873 51 04-00	Nut Keps Hex 1/4-20 unc
62	532 43 40-17	Shield Heat
69	532 16 53-91	Gasket
70	581 88 11-01	Exhaust Tube RH
71	581 88 10-01	Exhaust Tube LH
79	532 18 39-06	Screw 5/16-18 x 1
81	532 14 84-56	Tube Drain Oil Easy
82	532 42 82-87	Valve Oil Drain
84	817 06 06-20	Screw 3/8-16 x 1-1/4
85	532 17 99-53	Bolt 7/16-20 x 3.75 Gr.
90	817 00 06-16	Screw 3/8-16 x 1
96	819 09 14-16	Washer 9/32 x 7/8 x 16 Ga.
97	817 67 04-12	Screw 1/4 - 20 x 3/4
102	817 00 05-12	Screw 5/16-18 x 5/8
105	501 26 86-02	Shield Side LH
106	501 26 87-02	Shield Side RH
108	587 17 95-03	Cover Pulley Engine w/SHLD 46"
115	532 43 17-61	Palnut #10
136	532 42 17-56	Screw, #10 0.500, BOS

NOTE: All component dimensions given in U.S. inches
1 inch = 25.4 mm

Engine Power Rating Information

The gross power rating for individual gas engine models is labeled in accordance with SAE (Society of Automotive Engineers) code J1940 (Small Engine Power & Torque Rating Procedure), and rating performance has been obtained and corrected in accordance with SAE J1995 (Revision 2002-05). Torque values are derived at 3060 RPM; horsepower values are derived at 3600 RPM. Actual gross engine power will be lower and is affected by, among other things, ambient operating conditions and engine-to-engine variability. Given both the wide array of products on which engines are placed and the variety of environmental issues applicable to operating the equipment, the gas engine will not develop the rated gross power when used in a given piece of power equipment (actual "on-site" or net power). This difference is due to a variety of factors including, but not limited to, accessories (air cleaner, exhaust, charging, cooling, carburetor, fuel pump, etc.), application limitations, ambient operating conditions (temperature, humidity, altitude), and engine-to-engine variability. Due to manufacturing and capacity limitations, Briggs & Stratton may substitute an engine of higher rated power for this Series engine.

**TRACTOR - - MODEL NO. M200-117T (96041033902), PRODUCT NO. 960 41 03-39
STEERING ASSEMBLY 41**

KEY NO.	PART NO.	DESCRIPTION
1	532 42 45-51	Wheel, Steering
2	532 41 81-68	Axle Asm., Front
4	532 40 30-87	Spindle Asm., LH
5	532 40 30-88	Spindle Asm., RH
6	532 12 49-31	Bearing, Race Thrust Harden
7	532 12 17-48	Washer 25/32 x 1-5/8 x 16 Ga.
8	812 00 00-29	Ring, Clip #T5304-75
9	532 12 12-32	Cap, Spindle
13	532 12 17-49	Washer 25/32 x 1-1/4 x 16 Ga.
14	810 04 06-00	Washer, Lock Hvy Hlcl Spr 3/8
15	873 54 06-00	Nut, Crown Lock 3/8-24 unf
16	587 01 60-02	Steering Shaft
19	532 19 47-29	Plate Steering
20	532 42 47-40	Boot Steering
21	586 84 02-01	Adapter Wheel Steering
22	585 02 98-02	Bearing
26	532 42 45-53	Insert, Wheel Steering
27	819 21 16-16	Washer
28	817 00 06-12	Screw 3/8-16 x 3/4
35	532 19 47-32	Gear, Sector Plate
45	587 01 64-01	Washer 3/8 ID 2-3/8 OD 12 Ga. PLTD
50	873 90 06-00	Nut Lock Flg 3/8-16 unc
53	532 18 89-67	Washer Hardened .793 x 1.637 x .060
57	532 40 74-65	Bracket Upstop
58	532 19 47-47	Bolt Shoulder Sector Pivot CFM
59	532 19 47-48	Washer Thrust Sector Steering
60	873 97 10-00	Nut Flange Lock 5/8-11
61	532 19 47-40	Draglink LH
62	532 19 47-41	Draglink, RH
63	817 00 05-12	Screw 5/16-18 x 3/4
64	532 19 98-49	Retainer Clip Spring Steering
66	871 02 07-48	Bolt Hex Fghd 7/16-14 x 3 Serr
67	532 19 47-37	Bushing PM Front Axle
68	873 90 07-00	Nut Lock Flange 7/16-14 Gr. 5
69	532 19 91-62	Washer 1.5 x .505 x .118
70	585 33 88-01	Bracket Deck Susp. Front
74	532 12 49-37	Bearing
75	580 68 37-01	Pinion
76	580 68 36-01	Screw Head Sock
122	532 44 49-62	Cap Gear Sector

NOTE: All component dimensions given in U.S. inches
1 inch = 25.4 mm

TRACTOR -- MODEL NO. M200-117T (96041033902), PRODUCT NO. 960 41 03-39
 MOWER DECK **44**

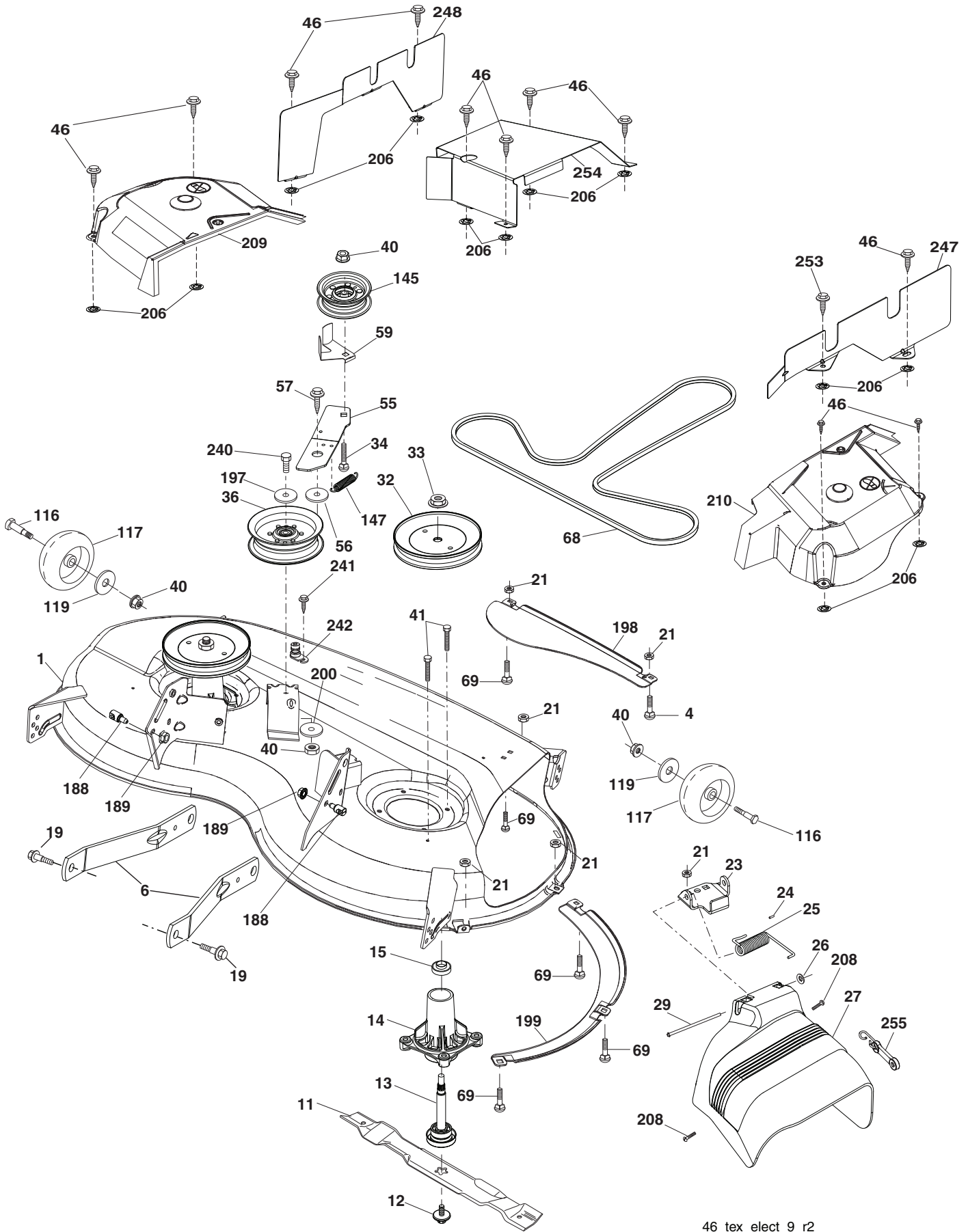

46_tex_elect_9_r2

**TRACTOR - - MODEL NO. M200-117T (96041033902), PRODUCT NO. 960 41 03-39
MOWER DECK 44**

KEY NO.	PART NO.	DESCRIPTION	KEY NO.	PART NO.	DESCRIPTION
1	589 53 53-15	Mower Housing	147	532 19 72-51	Spring Return
4	874 76 05-12	Bolt Hex Hd 5/16-18 unc	188	532 19 51-61	Stud Fastener
6	532 19 51-86	Arm Suspension	189	873 90 05-00	Nut Lock Hex Flange
11	532 40 53-80	Blade Mower Hi Lift	197	819 13 13-12	Washer 13/32 x 13/16 x 12 Ga.
12	584 30 93-01	Screw Sems 7/16-20 x 1 Hex	198	532 40 31-49	Baffle Center Front
13	587 25 65-01	Shaft Assembly, Mandrel	199	532 40 31-50	Baffle Front RH
14	532 18 72-81	Housing, Mandrel	200	532 41 35-24	Washer 13/32 x 1 x 1/2 11 GAHRD
15	585 32 39-01	Bearing, Mandrel	206	532 42 30-62	Palnut 1/4
19	532 19 65-39	Bolt, Shoulder	208	817 67 06-08	Screw Thdrol 3/8-16 x 1/2
21	873 68 05-00	Nut	209	588 80 88-01	Cover Asm LH
23	532 19 25-57	Bracket, Deflector	210	532 43 23-96	Cover Asm RH
24	532 10 53-04	Cap, Sleeve	240	874 52 06-36	Bolt 3/8-16 unc x 2-1/4 Gr. 5
25	532 19 70-26	Spring, Torsion, Deflector	241	532 15 29-27	Screw
26	532 11 04-52	Nut, Push	242	532 41 55-98	Washout Port
27	532 44 28-95	Shield, Deflector	247	532 43 02-63	Cover Asm RH
29	532 13 14-91	Rod, Hinge	248	532 43 02-62	Cover Asm LH
32	532 19 74-73	Pulley, Mandrel	253	532 42 73-50	Rivet Tuflok .25 x .24
33	532 40 02-34	Nut, Toplock, Flanged	254	532 43 02-64	Shield Deck Rear
34	872 11 06-12	Bolt Carr Sh. 3/8-16 x 1-1/2 Gr. 5	255	532 43 60-87	Kit Bungee (Includes Phillips head screw, weld nut, screw, bungee latch, and bungee strap)
36	532 19 73-79	Pulley, Idler, Flat	--	587 25 33-01	Mandrel Assembly (Includes housing (key #14), shaft assem- bly (key #13), bearing (key #15) and nut (key #33) only - pulley/ washer and blade bolt/washers not included)
40	873 90 06-00	Nut, Lock Flg. 3/8-16 unc	--	532 42 72-24	Replacement Mower, Complete
41	584 95 39-01	Bolt Hex			
46	532 13 77-29	Screw 1/4-20 x 5/8			
55	532 19 72-49	Arm, Idler			
56	532 19 90-92	Spacer, Retainer			
57	817 00 06-16	Screw Hexwsh Thd 3/8-16 x 1			
59	532 14 10-43	Guard, Tuv Idler (94)			
68	532 40 51-43	V-Belt			
69	872 14 05-05	Bolt			
116	532 19 34-06	Bolt, Shoulder			
117	532 17 48-73	Wheel, Gauge			
119	819 13 20-12	Washer 13/32 x 1-1/2 x 11 Ga.			
145	532 19 31-97	Pulley Idler			

NOTE: All component dimensions given in U.S. inches
1 inch = 25.4 mm

TRACTOR -- MODEL NO. M200-117T (96041033902), PRODUCT NO. 960 41 03-39
MOWER LIFT 45

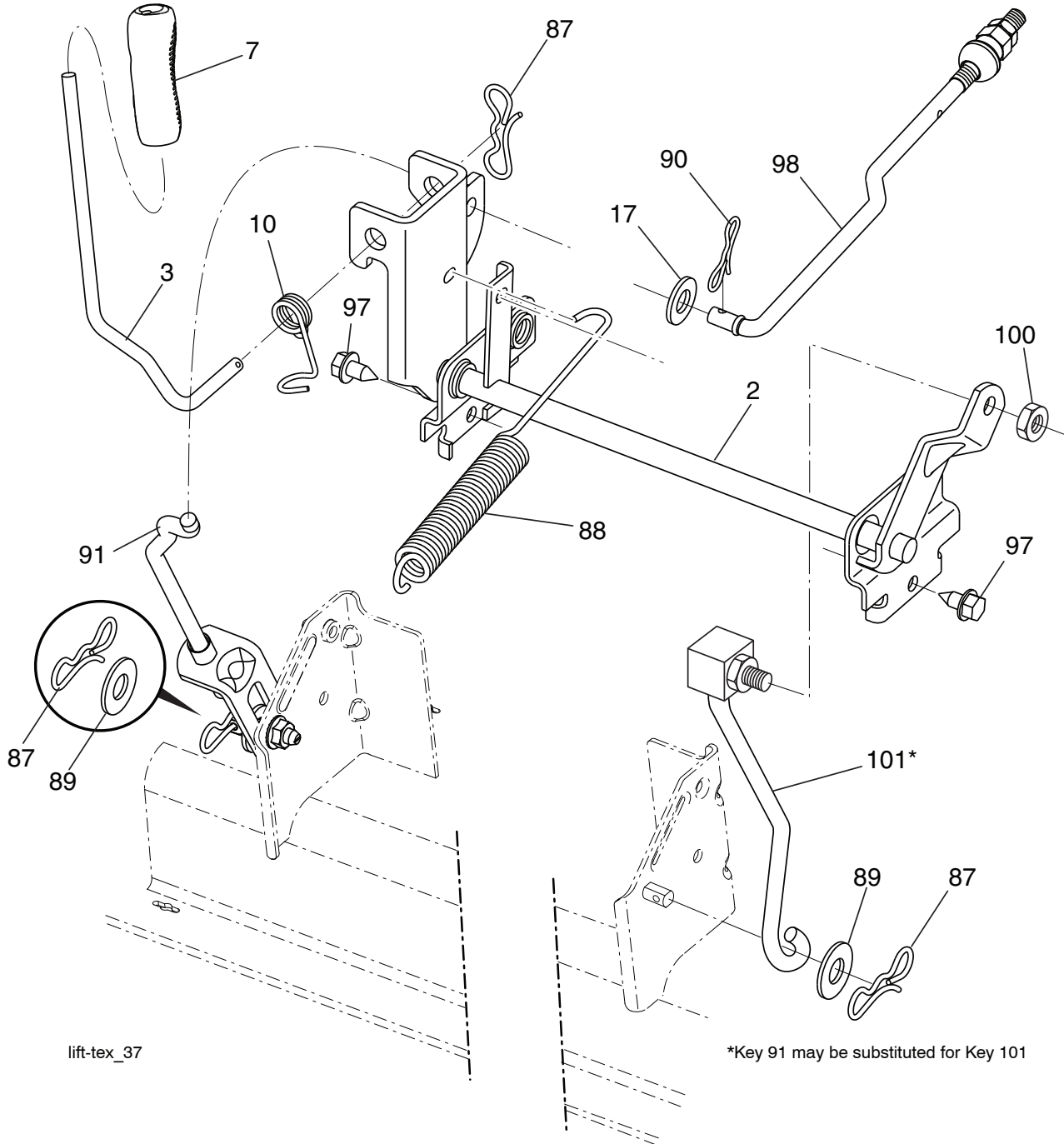

lift-tex_37

*Key 91 may be substituted for Key 101

KEY NO.	PART NO.	DESCRIPTION
2	532 42 20-27	Shaft Asm., Lift
3	532 19 52-31	Lever Asm., Lift RH
7	580 96 23-01	Grip, Lever
10	532 19 63-14	Spring Torsion
17	819 13 13-12	Washer 13/32 x 13/16 x 12 Ga.
87	532 19 42-09	Pin Cotter 7/16 Bow Tie Lock
88	532 41 07-10	Spring Lift Assist
89	819 19 19-12	Washer 17/32 x 1-3/16 x 12 Ga.

KEY NO.	PART NO.	DESCRIPTION
90	532 19 42-08	Pin Cotter 5/16 Bow Tie Lock
91	532 19 79-84	Lift Link Asm. Rear
97	817 00 06-12	Screw 3/8-16 x .75
98	532 42 05-25	Link Lift Susp. Front Mower
100	873 93 06-00	Nut Centerlock 3/8-16 unc
101	581 50 65-01	Link Asm. Fixed

NOTE: All component dimensions given in U.S. inches
 1 inch = 25.4 mm

**TRACTOR - - MODEL NO. M200-117T (96041033902), PRODUCT NO. 960 41 03-39
SEAT ASSEMBLY 42**

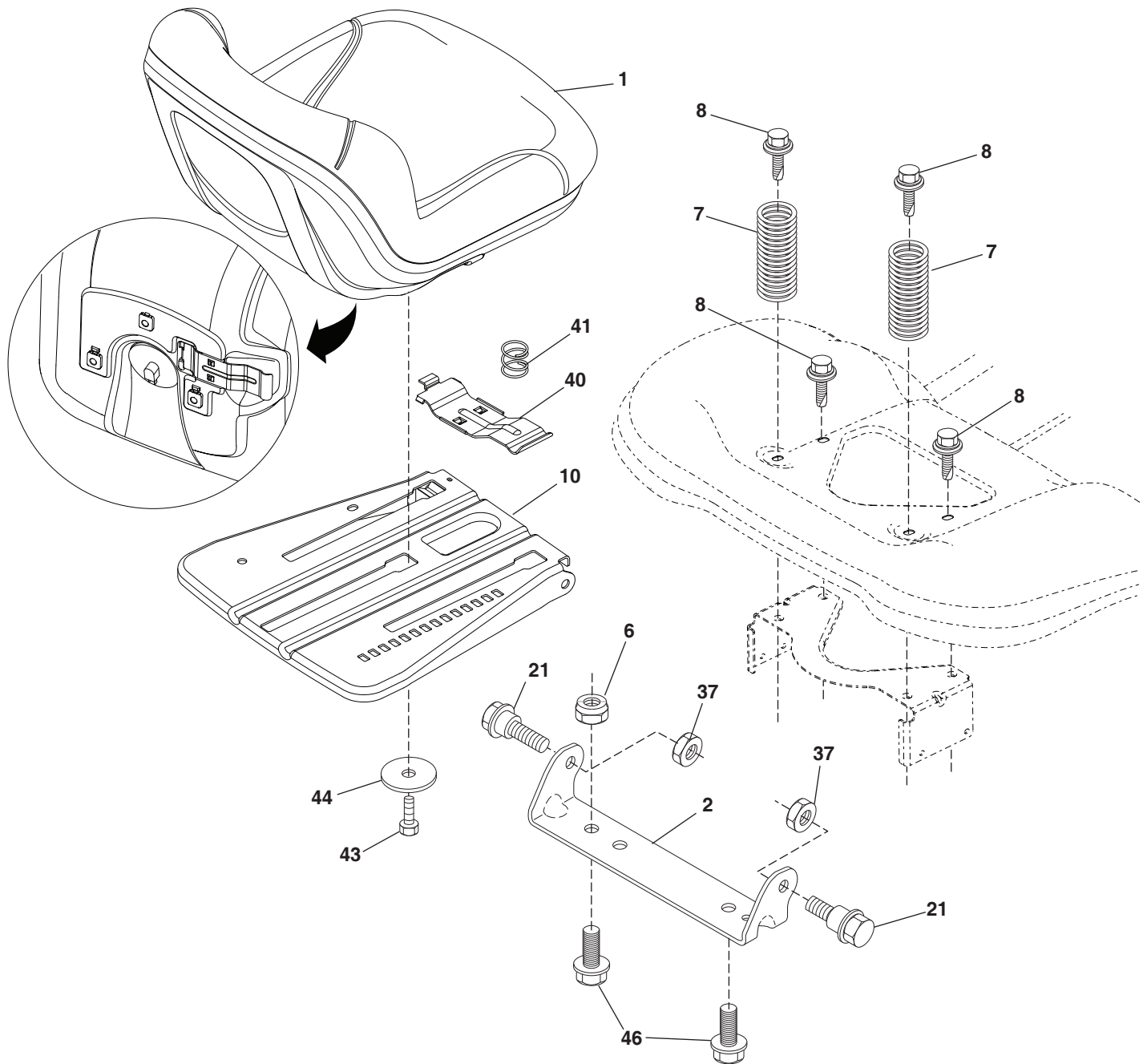

seat-tex_6.5SL_9

KEY NO.	PART NO.	DESCRIPTION
1	581 46 22-01	Seat
2	532 18 01-66	Bracket Pivot Fender
6	873 80 06-00	Nut, Lock w/Ins. 3/8-16 unc
7	587 61 33-01	Spring, Seat Cprsn
8	532 17 18-77	Bolt 5/16-18 unc x 3/4 w/Sems
10	532 19 69-77	Pan, Seat
21	587 90 78-01	Bolt, Shoulder 5/16-18 x 5/8
37	873 80 05-00	Nut, Lock 5/16-18 unc

KEY NO.	PART NO.	DESCRIPTION
40	532 19 76-61	Handle Slide Seat
41	532 19 82-00	Spring Latch Seat
43	874 76 06-12	Bolt 3/8-16 x 3/4
44	819 13 38-12	Washer 13/32 x 2-3/8 x 12 Ga.
46	588 09 04-01	Bolt 3/8-16 x 1, 1.25 OD Wash.

NOTE: All component dimensions given in U.S. inches
1 inch = 25.4 mm

