

ILLUSTRATED PARTS LIST

MODEL NUMBER ST 68EP

PRODUCT NUMBER 961 91 00-65

MFG. ID. NUMBER 96191006503

REPAIR PARTS

AUGER HOUSING / IMPELLER ASSEMBLY

SNOW THROWER - MODEL NO. ST 68EP (96191006503), PRODUCT NO. 961 91 00-65

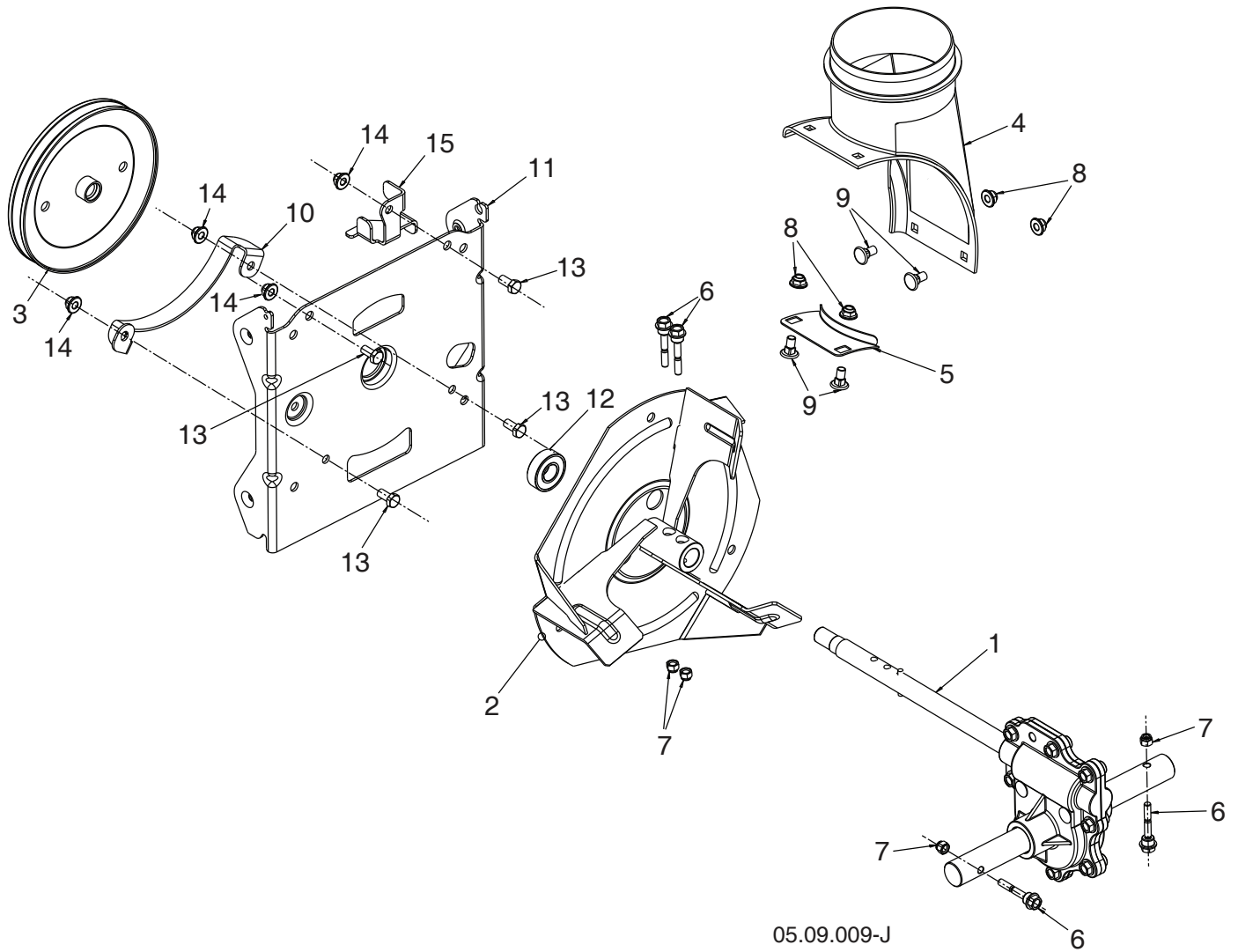

NOTE: All component dimensions given in U.S. inches. 1 inch = 25.4 mm
IMPORTANT: Use only Original Equipment Manufacturer (O.E.M.) replacement parts.
Failure to do so could be hazardous, damage your snow thrower and void your warranty.

REPAIR PARTS**AUGER HOUSING / IMPELLER ASSEMBLY****SNOW THROWER - MODEL NO. ST 68EP (96191006503), PRODUCT NO. 961 91 00-65**

| KEY NO. | PART NO. | DESCRIPTION |
|----------------|-----------------|--|
| 1 | 501 14 96-01 | GEARBOX AUGER |
| 2 | 586 60 72-02 | IMPELLER STEEL |
| 3 | 587 40 24-01 | PULLEY IMPELLER – SCREW ON |
| 4 | 585 05 69-01 | CHUTE DISCHARGE BASE |
| 5 | 532 18 40-95 | BRACKET CORNER DISCHARGE BASE |
| 6 | 588 07 75-01 | BOLT SHEAR 1/4-20 |
| 7 | 873 80 04-00 | NUT NYLOCK 1/4-20 |
| 8 | 585 69 13-01 | NUT FLANGE NYLOCK 5/16-18 - BLK |
| 9 | 585 69 12-01 | BOLT CARRIAGE WAFER HEAD 5/16-18 X 5/8 BLK |
| 10 | 581 63 20-02 | BRACKET BELT KEEPER LOWER |
| 11 | 581 59 25-02 | BRACKET INTERFACE |
| 12 | 532 19 87-91 | BEARING BALL |
| 13 | 532 16 31-83 | SCREW HEX HEAD 5/16-18 X 5/8 |
| 14 | 532 42 79-42 | NUT FLANGE NYLOCK 5/16-18 |
| 15 | 587 58 72-02 | LOWER AUGER BELT GUIDE |

NOTE: All component dimensions given in U.S. inches. 1 inch = 25.4 mm
IMPORTANT: Use only Original Equipment Manufacturer (O.E.M.) replacement parts.
Failure to do so could be hazardous, damage your snow thrower and void your warranty.

REPAIR PARTS

AUGER HOUSING / IMPELLER ASSEMBLY

SNOW THROWER - MODEL NO. ST 68EP (96191006503), PRODUCT NO. 961 91 00-65

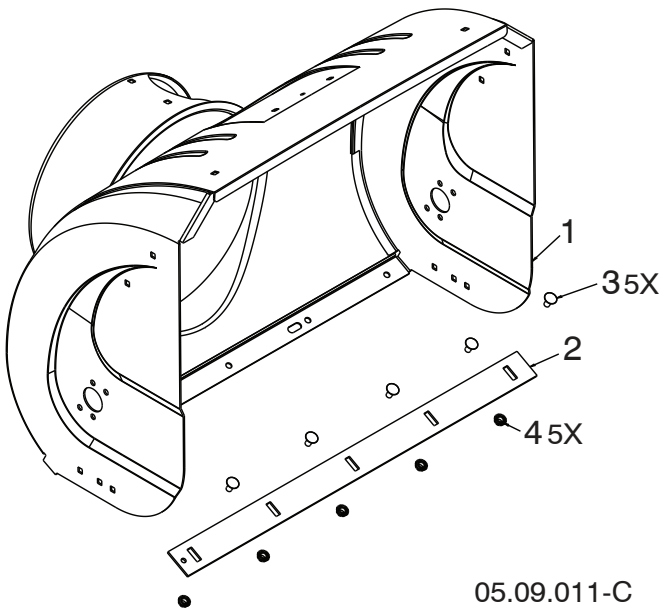

| KEY NO. | PART NO. | DESCRIPTION |
|---------|--------------|----------------------------------|
| 1 | 581 70 83-73 | AUGER HOUSING |
| 2 | 532 40 77-27 | SCRAPER BAR |
| 3 | 872 27 05-05 | CARRIAGE BOLT 5/16-18 X .625 GR5 |
| 4 | 532 15 53-77 | NUT 5/16-18 |

05.09.011-C

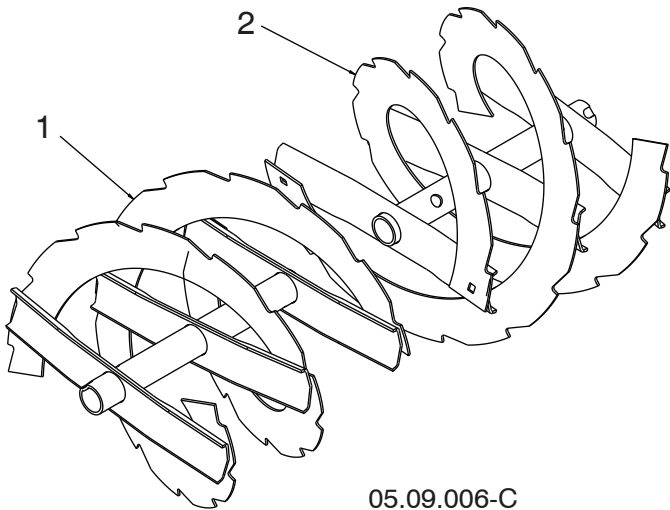

| KEY NO. | PART NO. | DESCRIPTION |
|---------|--------------|-------------|
| 1 | 532 42 11-35 | AUGER 27 LH |
| 2 | 532 42 11-23 | AUGER 27 RH |

05.09.006-C

NOTE: All component dimensions given in U.S. inches. 1 inch = 25.4 mm
IMPORTANT: Use only Original Equipment Manufacturer (O.E.M.) replacement parts. Failure to do so could be hazardous, damage your snow thrower and void your warranty.

REPAIR PARTS

AUGER HOUSING / IMPELLER ASSEMBLY

SNOW THROWER - MODEL NO. ST 68EP (96191006503), PRODUCT NO. 961 91 00-65

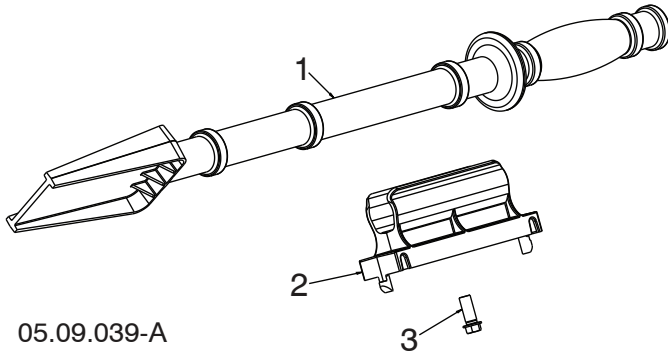

| KEY NO. | PART NO. | DESCRIPTION |
|---------|--------------|------------------------------|
| 1 | 532 19 21-99 | TOOL CLEANOUT |
| 2 | 532 40 54-00 | CLIP CLEANOUT TOOL |
| 3 | 532 19 41 89 | SCREW HEX WASHER 13-16 X 5/8 |

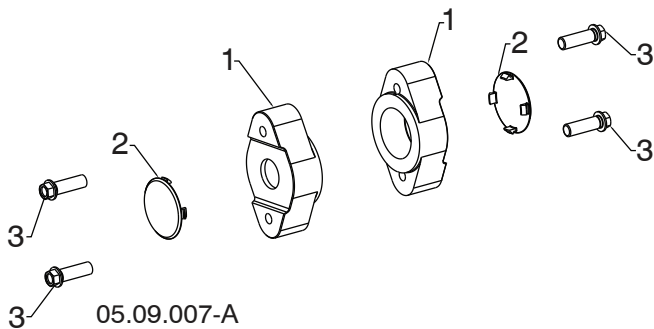

| KEY NO. | PART NO. | DESCRIPTION |
|---------|--------------|----------------------------------|
| 1 | 532 42 04-78 | AUGER BEARING |
| 2 | 532 41 19-39 | BEARING PLUG |
| 3 | 584 29 94-01 | SCREW HI-LO WASHD 5/16-14 X 1.00 |

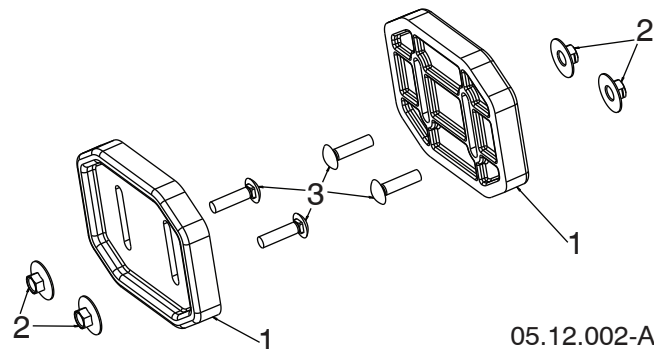

| KEY NO. | PART NO. | DESCRIPTION |
|---------|--------------|------------------------------------|
| 1 | 532 43 59-51 | PLATE SKID PLASTIC HDPE |
| 2 | 585 80 28-01 | NUT LARGE FLANGE 5/16-18 - BLK |
| 3 | 585 80 29-01 | BOLT CARRIAGE 5/16-18 X 1.25 - BLK |

NOTE: All component dimensions given in U.S. inches. 1 inch = 25.4 mm
IMPORTANT: Use only Original Equipment Manufacturer (O.E.M.) replacement parts. Failure to do so could be hazardous, damage your snow thrower and void your warranty.

REPAIR PARTS

CONTROL PANEL / DISCHARGE CHUTE

SNOW THROWER - MODEL NO. ST 68EP (96191006503), PRODUCT NO. 961 91 00-65

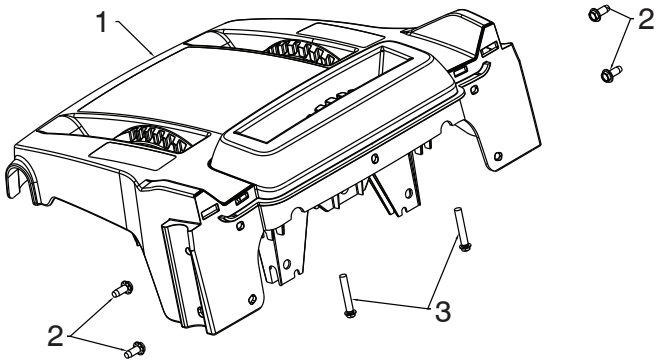

05.07.021-A

| KEY NO. | PART NO. | DESCRIPTION |
|---------|--------------|----------------------------------|
| 1 | 581 13 12-06 | CONSOLE BASE MULTI CONTROL |
| 2 | 817 06 04-10 | SCREW TA SEMI GIMLE 1/4-20 X .62 |
| 3 | 581 32 95-01 | SCREW HEX WASHER 13-16 X 1.50 |

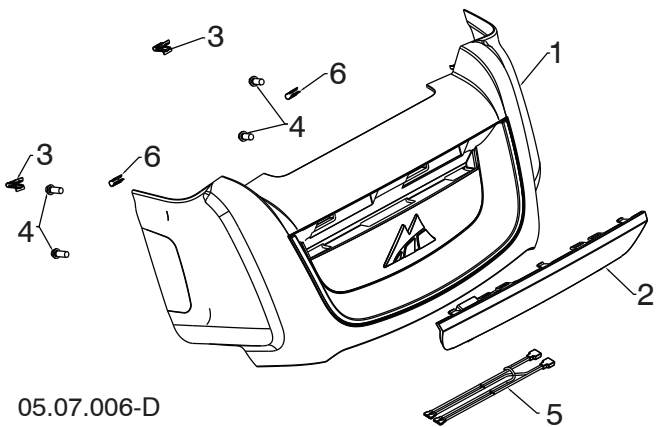

05.07.006-D

| KEY NO. | PART NO. | DESCRIPTION |
|---------|--------------|-----------------------------|
| 1 | 585 51 19-01 | MCCULLOCH CONSOLE COVER ASM |
| 2 | 585 70 65-01 | LIGHT ASSEMBLY |
| 3 | 581 92 87-01 | PANEL CLIP |
| 4 | 532 19 41-89 | SCREW HI-LO 13-16 X 5/8 |
| 5 | 585 86 83-01 | WIRE HARNESS LIGHT JUMPER |
| 6 | 587 69 84-01 | CLIP U SPRING |

NOTE: All component dimensions given in U.S. inches. 1 inch = 25.4 mm
IMPORTANT: Use only Original Equipment Manufacturer (O.E.M.) replacement parts. Failure to do so could be hazardous, damage your snow thrower and void your warranty.

REPAIR PARTS

CONTROL PANEL / DISCHARGE CHUTE

SNOW THROWER - MODEL NO. ST 68EP (96191006503), PRODUCT NO. 961 91 00-65

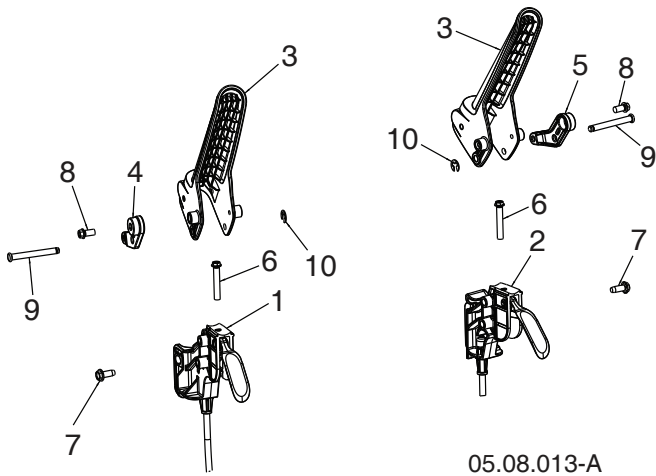

| KEY NO. | PART NO. | DESCRIPTION |
|---------|--------------|--------------------------|
| 1 | 588 26 39-01 | CABLE, POWER STEER - LHS |
| 2 | 588 26 39-02 | CABLE, POWER STEER - RHS |
| 3 | 587 46 30-01 | LEVER, CONTROL |
| 4 | 587 73 97-01 | LEVER, CABLE ARM - LHS |
| 5 | 587 73 97-02 | LEVER, CABLE ARM - RHS |
| 6 | 581 32 95-01 | SCREW HI-LO 13-16 X 1.50 |
| 7 | 817 06 04-10 | SCREW 1/4-20 X .625 |
| 8 | 817 41 13-08 | SCREW HI-LW 13-16 X .500 |
| 9 | 588 14 77-01 | PIN, GROOVED |
| 10 | 812 00 00-14 | E-RING |

05.08.013-A

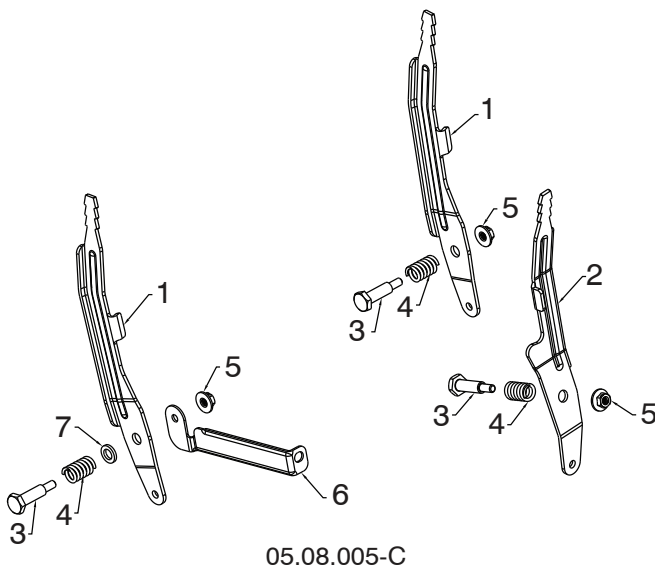

| KEY NO. | PART NO. | DESCRIPTION |
|---------|--------------|-------------------------------------|
| 1 | 581 12 39-02 | LEVER CONTROL SPEED/DEFL |
| 2 | 581 24 16-02 | LEVER CONTROL CHUTE ROT |
| 3 | 581 32 97-01 | BOLT SHOULDER 1/4-20 |
| 4 | 581 32 96-01 | SPRING COMPRESSION |
| 5 | 586 66 89-01 | NUT FL LOCK 1/4-20 |
| 6 | 584 46 84-02 | BRACE SUPPORT SPEED |
| 7 | 587 03 13-01 | WASHER .625 X .375 X .094 NYLON 6/6 |

05.08.005-C

NOTE: All component dimensions given in U.S. inches. 1 inch = 25.4 mm
IMPORTANT: Use only Original Equipment Manufacturer (O.E.M.) replacement parts. Failure to do so could be hazardous, damage your snow thrower and void your warranty.

REPAIR PARTS

CONTROL PANEL / DISCHARGE CHUTE

SNOW THROWER - MODEL NO. ST 68EP (96191006503), PRODUCT NO. 961 91 00-65

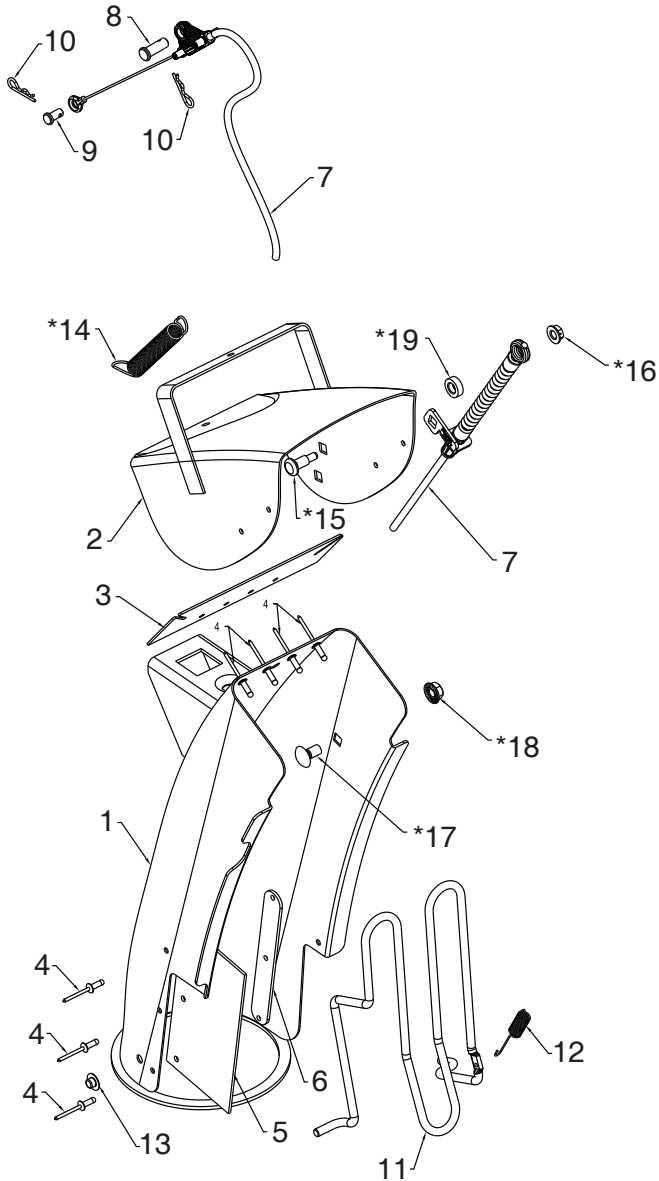

05.11.008-E

| KEY NO. | PART NO. | DESCRIPTION |
|---------|--------------|--|
| 1 | 588 07 78-03 | CHUTE WELDMENT (INCLUDES 1, 2, 3, 4, 5, 6) |
| 2 | ----- | DEFLECTOR WELDMENT |
| 3 | ----- | DEFLECTOR SEAL |
| 4 | ----- | POP RIVET |
| 5 | ----- | CHUTE SNOW SHIELD |
| 6 | ----- | SHIELD STRAP RETAINER |
| 7 | 586 96 15-01 | CABLE ASM DEFLECTOR - BOWDEN |
| 8 | 581 32 94-01 | PIN CLEVIS 5/16 X .875 |
| 9 | 585 80 83-01 | PIN CLEVIS 1/4 X .312 |
| 10 | 532 42 33-03 | HAIRPIN RETAINER |
| 11 | 532 43 55-82 | CHUTE GUARD |
| 12 | 532 43 56-16 | GUARD RETURN SPRING |
| 13 | 532 05 93-49 | PUSH NUT |
| *14 | 532 18 45-05 | DEFLECTOR SPRING |
| *15 | 501 41 73-01 | CARRIAGE BOLT 1/4-20 X .544 |
| *16 | 585 69 14-01 | NUT 1/4-20 |
| *17 | 585 83 20-01 | CARRIAGE BOLT 3/8-16 X .625 |
| *18 | 873 97 05-00 | NUT 5/16-18 |
| *19 | 501 41 74-01 | WASHER .326 X .625 X .205 NYLON |

NOTE: ALL ITEMS MARKED WITH AN * ARE PROVIDED IN THE BAG OF ITEMS SHIPPED LOOSE WITH PRODUCT.

NOTE: All component dimensions given in U.S. inches. 1 inch = 25.4 mm
IMPORTANT: Use only Original Equipment Manufacturer (O.E.M.) replacement parts. Failure to do so could be hazardous, damage your snow thrower and void your warranty.

REPAIR PARTS

CONTROL PANEL / DISCHARGE CHUTE

SNOW THROWER - MODEL NO. ST 68EP (96191006503), PRODUCT NO. 961 91 00-65

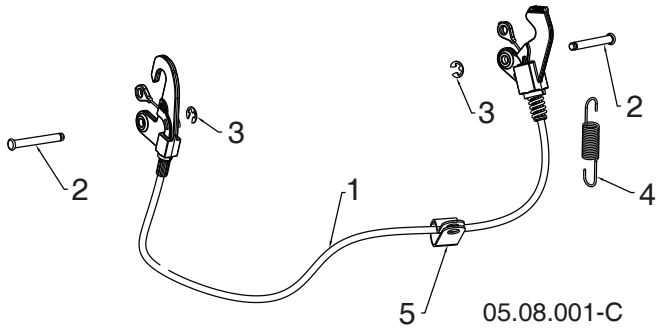

| KEY NO. | PART NO. | DESCRIPTION |
|---------|--------------|------------------|
| 1 | 587 33 25-02 | CABLE INTERLOCK |
| 2 | 532 43 17-62 | PIN GROOVED |
| 3 | 812 00 00-14 | E-RING |
| 4 | 581 15 12-01 | SPRING RETURN |
| 5 | 532 19 79-91 | CLIP CABLE BLACK |

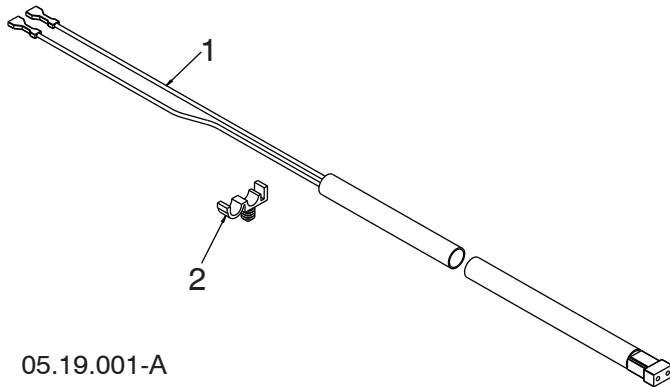

| KEY NO. | PART NO. | DESCRIPTION |
|---------|--------------|--------------------|
| 1 | 588 06 42-01 | HARNES WIRE LIGHTS |
| 2 | 532 14 50-06 | WIRE RETAINER |

NOTE: All component dimensions given in U.S. inches. 1 inch = 25.4 mm
IMPORTANT: Use only Original Equipment Manufacturer (O.E.M.) replacement parts.
 Failure to do so could be hazardous, damage your snow thrower and void your warranty.

REPAIR PARTS

CONTROL PANEL / DISCHARGE CHUTE

SNOW THROWER - MODEL NO. ST 68EP (96191006503), PRODUCT NO. 961 91 00-65

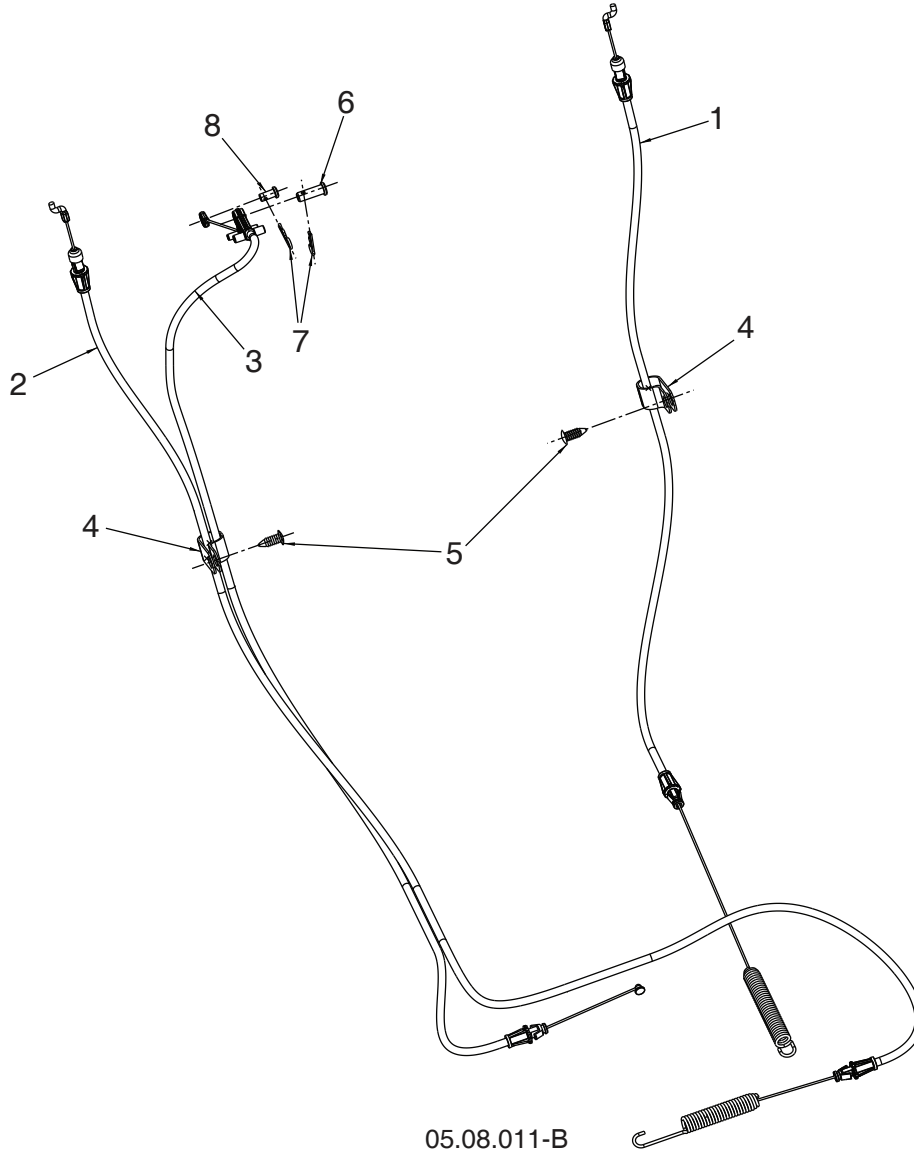

05.08.011-B

| KEY NO. | PART NO. | DESCRIPTION |
|---------|--------------|---------------------|
| 1 | 588 11 37-02 | CABLE CONTROL DRIVE |
| 2 | 588 11 38-01 | CABLE CONTROL AUGER |
| 3 | 588 12 23-01 | CABLE CONTROL SPEED |
| 4 | 532 19 79-91 | CLIP CABLE |
| 5 | 532 42 81-24 | FASTENER PUSH .250 |
| 6 | 581 32 94-01 | PIN CLEVIS 5/16 |
| 7 | 532 42 33-03 | HAIRPIN |
| 8 | 585 80 83-01 | PIN CLEVIS 1/4 |

NOTE: All component dimensions given in U.S. inches. 1 inch = 25.4 mm
IMPORTANT: Use only Original Equipment Manufacturer (O.E.M.) replacement parts. Failure to do so could be hazardous, damage your snow thrower and void your warranty.

REPAIR PARTS

CONTROL PANEL / DISCHARGE CHUTE

SNOW THROWER - MODEL NO. **ST 68EP** (96191006503), PRODUCT NO. 961 91 00-65

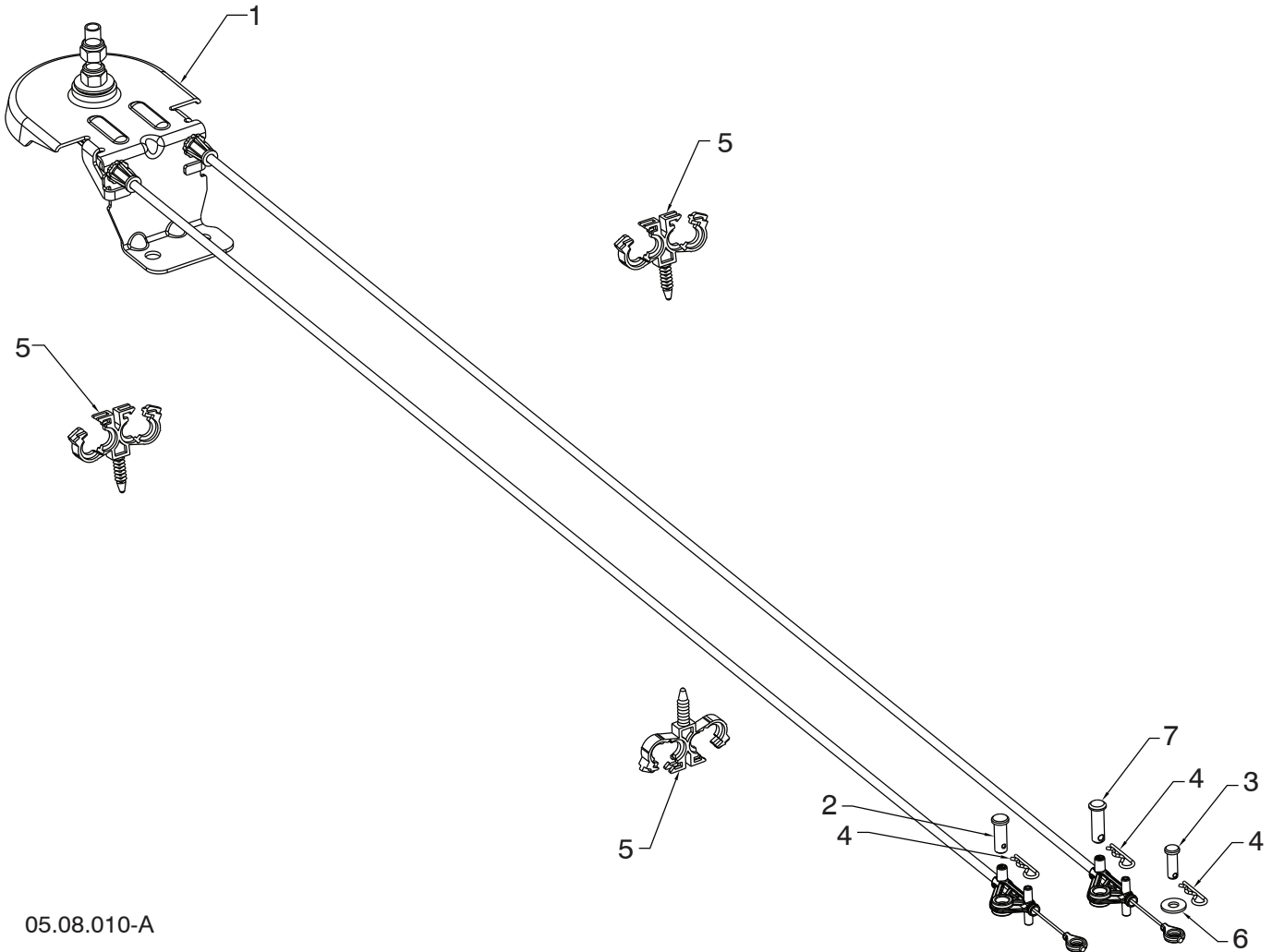

05.08.010-A

| KEY NO. | PART NO. | DESCRIPTION |
|---------|--------------|-------------------------|
| 1 | 587 80 34-01 | CABLE CHUTE ROTATOR ASM |
| 2 | 581 32 94-01 | PIN CLEVIS 5/6 X 7/8 |
| 3 | 877 10 08-12 | PIN CLEVIS 1/4 X 3/4 |
| 4 | 532 42 33-03 | HAIRPIN SOFT ZINC |
| 5 | 584 65 22-01 | CLIP CONDUIT DOUBLE |
| 6 | 586 68 21-01 | WASHER |
| 7 | 587 13 08-01 | PIN CLEVIS 5/16 X 1 |

NOTE: All component dimensions given in U.S. inches. 1 inch = 25.4 mm
IMPORTANT: Use only Original Equipment Manufacturer (O.E.M.) replacement parts.
 Failure to do so could be hazardous, damage your snow thrower and void your warranty.

REPAIR PARTS

HANDLES

SNOW THROWER - MODEL NO. ST 68EP (96191006503), PRODUCT NO. 961 91 00-65

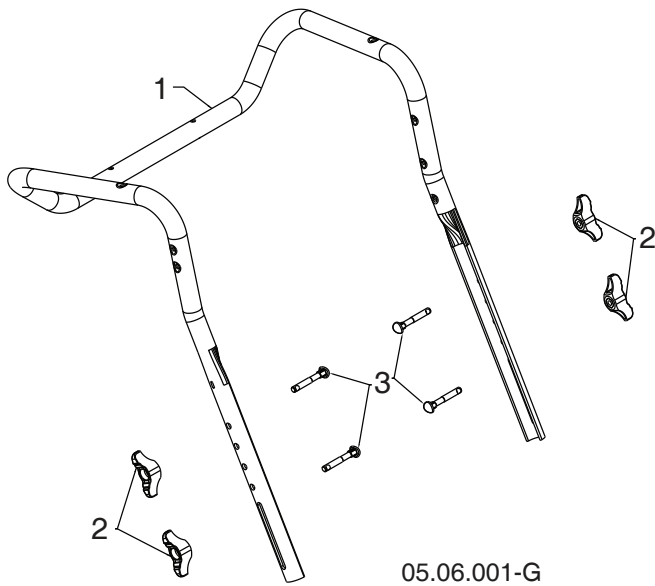

05.06.001-G

| KEY NO. | PART NO. | DESCRIPTION |
|---------|--------------|---|
| 1 | 588 16 08-02 | UPPER HANDLE |
| 2 | 532 19 19-38 | HANDLE KNOB STD BLACK |
| 3 | 588 05 99-01 | SCREW 5/16-18 X 2.25 CONCAVE HEAD WITH PATCH |

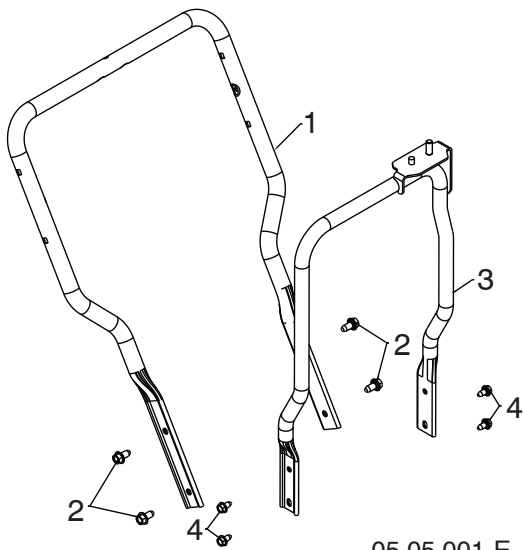

05.05.001-E

| KEY NO. | PART NO. | DESCRIPTION |
|---------|--------------|-----------------------------------|
| 1 | 588 67 21-02 | LOWER HANDLE |
| 2 | 817 00 06-12 | SCREW HEX WASH HD 3/8-16 X .75 |
| 3 | 581 62 20-02 | CHUTE ROTATOR SUPPORT ASM |
| 4 | 817 00 05-10 | BOLT HEX 5/16-18 |

NOTE: All component dimensions given in U.S. inches. 1 inch = 25.4 mm
IMPORTANT: Use only Original Equipment Manufacturer (O.E.M.) replacement parts.
 Failure to do so could be hazardous, damage your snow thrower and void your warranty.

REPAIR PARTS

DRIVE

SNOW THROWER - MODEL NO. ST 68EP (96191006503), PRODUCT NO. 961 91 00-65

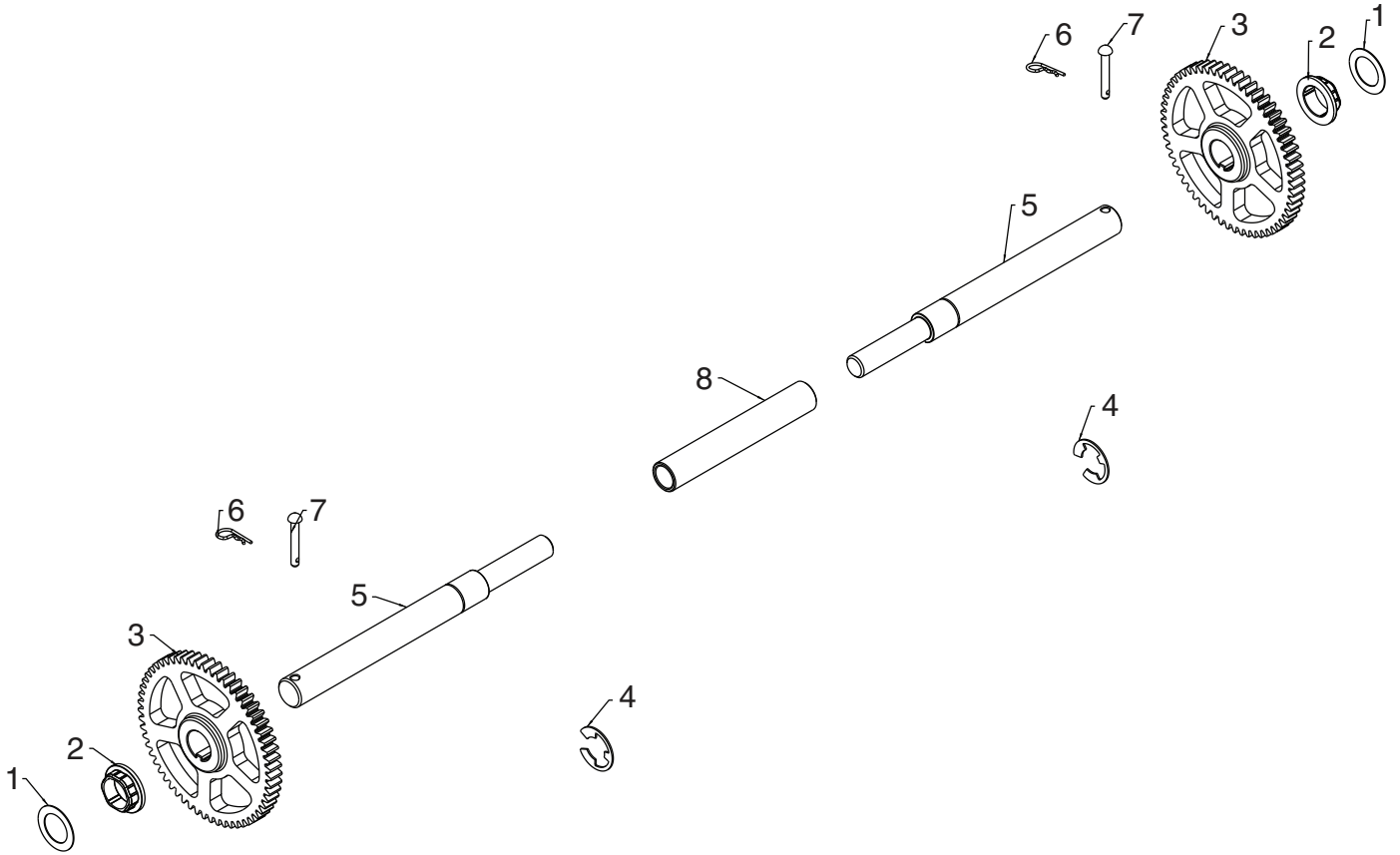

05.03.002-B

| KEY NO. | PART NO. | DESCRIPTION |
|---------|--------------|-----------------------------|
| 1 | 532 44 49-49 | WASHER 1.00 |
| 2 | 587 97 89-01 | BUSHING HEX 1 SHAFT |
| 3 | 588 51 86-01 | GEAR 59T DRIVEN |
| 4 | 812 00 00-53 | RETAINING RING |
| 5 | 580 75 26-01 | AXLE SHAFT SPLIT |
| 6 | 532 12 47-88 | RETAINER SPRING 1 ZINC |
| 7 | 532 17 12-71 | RIVET RD HD DRILLED 1/4 DIA |
| 8 | 580 75 25-01 | AXLE SLEEVE |

NOTE: All component dimensions given in U.S. inches. 1 inch = 25.4 mm
IMPORTANT: Use only Original Equipment Manufacturer (O.E.M.) replacement parts.
Failure to do so could be hazardous, damage your snow thrower and void your warranty.

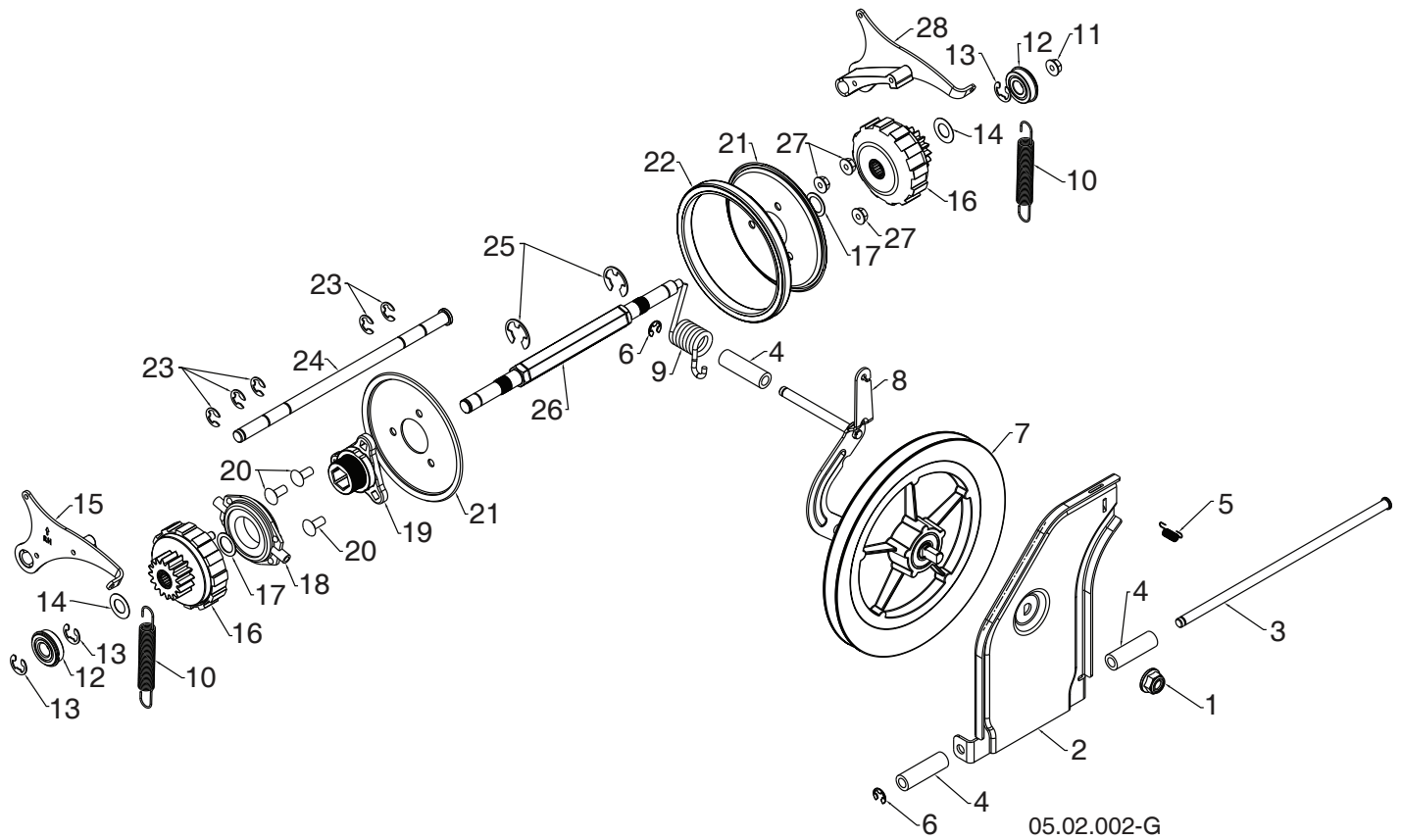

NOTE: All component dimensions given in U.S. inches. 1 inch = 25.4 mm
IMPORTANT: Use only Original Equipment Manufacturer (O.E.M.) replacement parts.
 Failure to do so could be hazardous, damage your snow thrower and void your warranty.

SNOW THROWER - MODEL NO. **ST 68EP** (96191006503), PRODUCT NO. 961 91 00-65

| KEY NO. | PART NO. | DESCRIPTION |
|---------|--------------|---------------------------------------|
| 1 | 521 99 11-01 | NUT HEX FLANGE LK 1/2-13 |
| 2 | 587 70 34-02 | SWING PLATE FRICTION PULL |
| 3 | 581 12 30-01 | ROD TIP PLATE |
| 4 | 581 73 27-01 | SPACER DRIVE |
| 5 | 532 19 38-85 | LATCH SPRING |
| 6 | 812 00 00-07 | E-RING RETAINER |
| 7 | 581 32 84-01 | FRICTION DISC COMBO PULLEY |
| 8 | 587 19 34-03 | BRACKET YOKE ASSEMBLY |
| 9 | 581 31 53-01 | SPRING TORSION DRIVE |
| 10 | 585 26 38-01 | EXTENSION SPRING |
| 11 | 585 69 15-01 | NUT HEX FLANGE LOCK 5/16-18 |
| 12 | 580 75 62-01 | BEARING 9/16 I.D. 1622-2RSNR |
| 13 | 580 75 61-02 | RETAINING RING 1622-2RSNR |
| 14 | 580 75 13-01 | WASHER FLAT .59 I.D. X 1.065 X 25 GA |
| 15 | 580 75 66-01 | PAWL ASM RH |
| 16 | 580 75 60-01 | GEAR ASM PLANETARY |
| 17 | 580 75 63-01 | WASHER FLAT .6875 I.D. X 1.00 X 21 GA |
| 18 | 532 17 53-44 | TRUNNION BEARING ASM |
| 19 | 581 09 09-01 | HUB RUBBER WHEEL |
| 20 | 872 11 05-06 | BOLT CARRIAGE 5/16-18 X .75 |
| 21 | 581 09 10-02 | PLATE RUBBER WHEEL |
| 22 | 581 09 11-01 | RING RUBBER WHEEL |
| 23 | 586 64 43-01 | E-RING |
| 24 | 580 75 51-01 | ROD PAWL |
| 25 | 812 00 00-22 | E-RING |
| 26 | 580 75 24-01 | SHAFT REDUCTION PWR STR |
| 27 | 532 75 11-53 | NUT HEX FLANGE LK 5/16-18 |
| 28 | 580 75 67-01 | PAWL ASM LH |

NOTE: All component dimensions given in U.S. inches. 1 inch = 25.4 mm

IMPORTANT: Use only Original Equipment Manufacturer (O.E.M.) replacement parts. Failure to do so could be hazardous, damage your snow thrower and void your warranty.

REPAIR PARTS

CHASSIS / ENGINE / PULLEYS

SNOW THROWER - MODEL NO. ST 68EP (96191006503), PRODUCT NO. 961 91 00-65

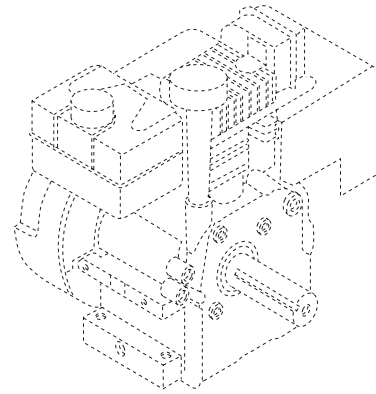
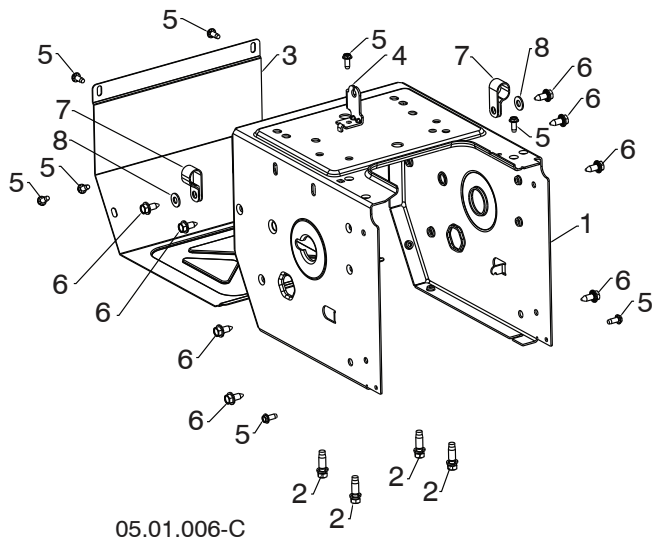

| KEY NO. | PART NO. | DESCRIPTION |
|---------|--------------|--|
| -- | ----- | B&S ENGINE 15C107-0029-F8 |
| 1 | 580 83 94-03 | FRAME |
| 2 | 532 15 04-06 | ENGINE BOLT 3/8-16 X 1.280 DOGPOINT |
| 3 | 580 83 95-03 | FRAME COVER |
| 4 | 501 06 04-03 | SHIFTER BRACKET |
| 5 | 817 06 04-10 | SCREW HEX WASHER 1/4-20 X 5/8 |
| 6 | 532 42 88-67 | BOLT HEXHD WASHER 5/16-18 X .75 |
| 7 | 532 19 79-91 | P CLIP |
| 8 | 585 69 09-01 | WASHER .343 X .750 X 16GA BLACK |

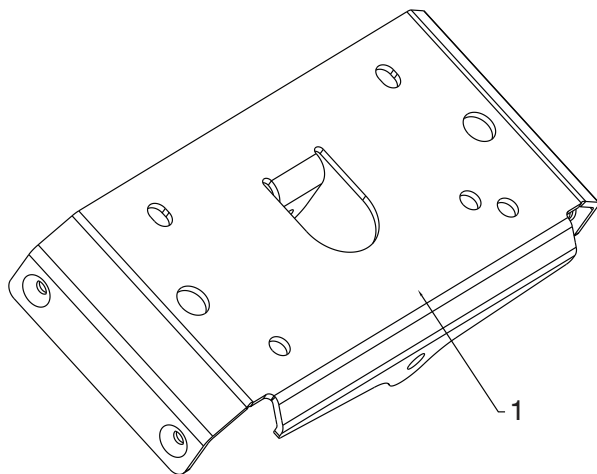

| KEY NO. | PART NO. | DESCRIPTION |
|---------|--------------|----------------------|
| 1 | 583 94 05-02 | SMALL MOUNTING PLATE |

NOTE: All component dimensions given in U.S. inches. 1 inch = 25.4 mm
IMPORTANT: Use only Original Equipment Manufacturer (O.E.M.) replacement parts.
 Failure to do so could be hazardous, damage your snow thrower and void your warranty.

REPAIR PARTS

CHASSIS / ENGINE / PULLEYS

SNOW THROWER - MODEL NO. ST 68EP (96191006503), PRODUCT NO. 961 91 00-65

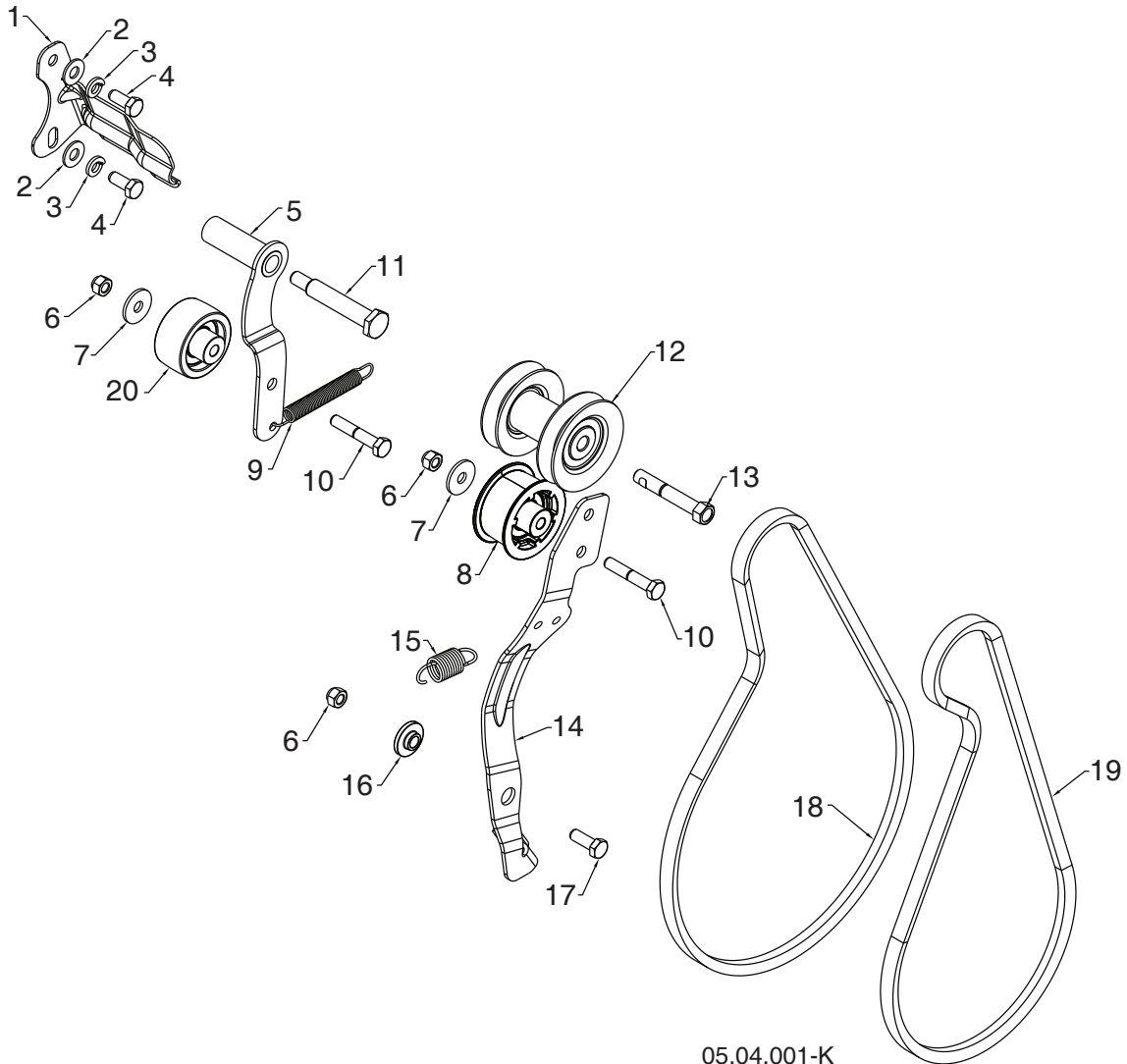

05.04.001-K

| KEY NO. | PART NO. | DESCRIPTION | KEY NO. | PART NO. | DESCRIPTION |
|---------|--------------|-----------------------------------|---------|--------------|--------------------------------------|
| 1 | 588 49 28-02 | BELT KEEPER BRACKET | 11 | 581 41 38-01 | SHOULDER BOLT 5/16-24 X 2.15 |
| 2 | 819 11 12-16 | WASHER 11/32 X 3/4 X 16 GA | 12 | 587 89 37-03 | PULLEY ASM ENGINE |
| 3 | 810 04 05-00 | LOCKWASHER 5/16 SPLIT HVY | 13 | 582 38 84-01 | BOLT HEXHD 3/8-24 X 2.375 |
| 4 | 874 61 05-12 | CAPSCREW HEXHD 5/16-24 X .75 GR 5 | 14 | 580 83 11-06 | ARM IDLER |
| 5 | 581 33 82-03 | IDLER ARM DRIVE WELDMENT | 15 | 587 03 12-01 | RETURN SPRING IDLER ARM |
| 6 | 873 80 05-00 | NUT NYLOCK 5/16-18 | 16 | 587 34 37-01 | BUSHING IDLER PIVOT |
| 7 | 532 05 92-89 | WASHER FLAT .328 X 1.00 X .097 | 17 | 874 76 05-14 | BOLT HEXHD 5/16-18 X .875 |
| 8 | 581 14 14-01 | IDLER PULLEY 2.0 W/SPACER | 18 | 584 21 61-02 | DRIVE BELT 4L X 38.2 |
| 9 | 580 75 30-01 | RETURN SPRING IDLER ARM DRIVE | 19 | 501 81 82-01 | IMPELLER BELT |
| 10 | 874 76 05-28 | BOLT HEXHD 5/16-18 X 1.75 | 20 | 586 88 02-01 | IDLER PULLEY 2.0 FLANGELESS W/SPACER |

NOTE: All component dimensions given in U.S. inches. 1 inch = 25.4 mm
IMPORTANT: Use only Original Equipment Manufacturer (O.E.M.) replacement parts. Failure to do so could be hazardous, damage your snow thrower and void your warranty.

REPAIR PARTS

CHASSIS / ENGINE / PULLEYS

SNOW THROWER - MODEL NO. ST 68EP (96191006503), PRODUCT NO. 961 91 00-65

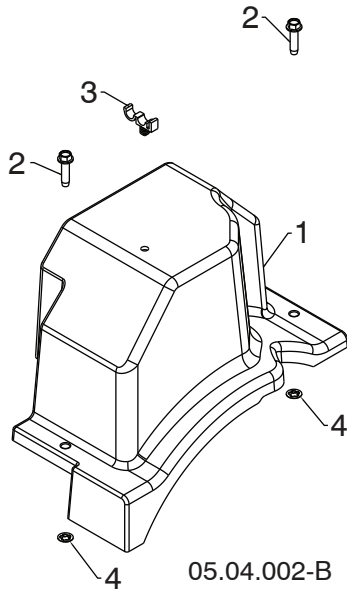

| KEY NO. | PART NO. | DESCRIPTION |
|---------|--------------|--|
| 1 | 587 10 54-01 | BELT COVER BLACK ASSEMBLY (INCLUDES 2 & 4) |
| 2 | ----- | BOLT HEX WSH THDRL 1/4-20 X 1 |
| 3 | 532 14 50-06 | CABLE GUIDE |
| 4 | ----- | PALNUT 1/4 IN |

NOTE: All component dimensions given in U.S. inches. 1 inch = 25.4 mm
IMPORTANT: Use only Original Equipment Manufacturer (O.E.M.) replacement parts. Failure to do so could be hazardous, damage your snow thrower and void your warranty.

REPAIR PARTS

WHEELS

SNOW THROWER - MODEL NO. **ST 68EP** (96191006503), PRODUCT NO. 961 91 00-65

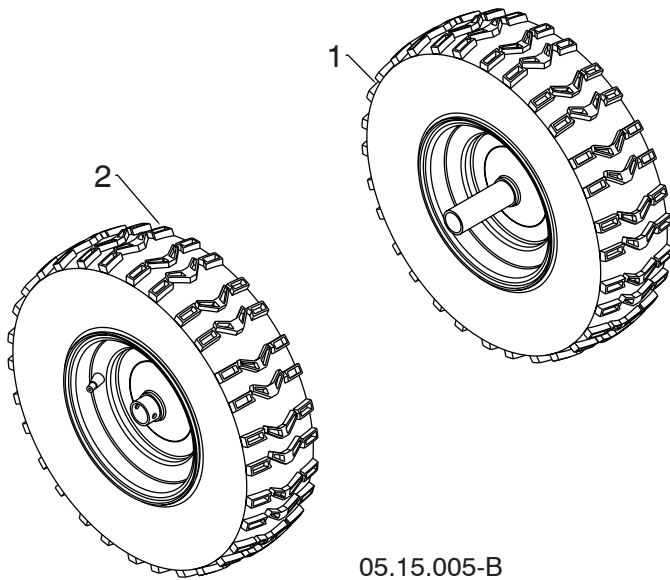

| KEY NO. | PART NO. | DESCRIPTION |
|---------|--------------|--------------------------------|
| 1 | 532 43 63-56 | WHEEL 16X4.80 NPS LH 1.00 K478 |
| 2 | 532 43 63-49 | WHEEL 16X4.80 NPS RH 1.00 K478 |

05.15.005-B

NOTE: All component dimensions given in U.S. inches. 1 inch = 25.4 mm
IMPORTANT: Use only Original Equipment Manufacturer (O.E.M.) replacement parts. Failure to do so could be hazardous, damage your snow thrower and void your warranty.

REPAIR PARTS

BAG OF PARTS

SNOW THROWER - MODEL NO. ST 68EP (96191006503), PRODUCT NO. 961 91 00-65

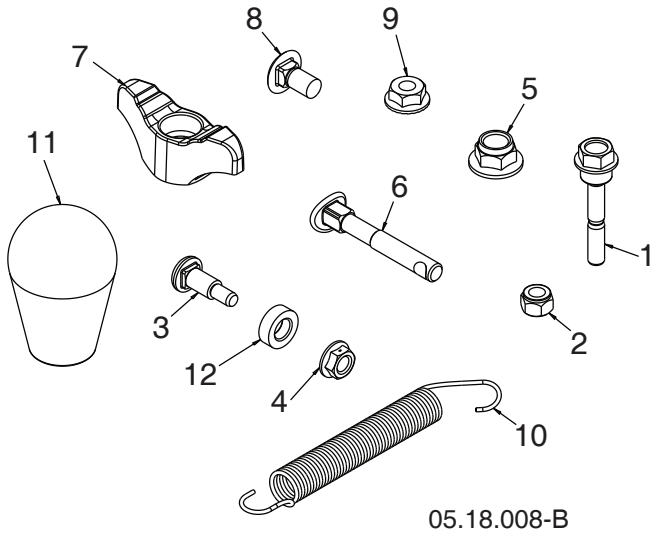

| KEY NO. | PART NO. | DESCRIPTION |
|---------|--------------|------------------------------|
| 1 | 588 07 75-01 | BOLT 1/4-20 X 1.81 |
| 2 | 873 80 04-00 | NUT NYLOCK 1/4-20 |
| 3 | 501 41 73-01 | BOLT SHOULDER |
| 4 | 585 69 14-01 | NUT HEX FL 1/4-20 CTR |
| 5 | 588 25 29-01 | NUT NYLOCK 3/8-16 |
| 6 | 588 05 99-01 | BOLT 5/16-18 X 2.25 CONCAVE |
| 7 | 532 18 97-13 | KNOB 5/16-18 X .625 |
| 8 | 585 83 20-01 | BOLT 5/16-18 X .625 |
| 9 | 873 97 05-00 | NUT SERR FL LOCK 5/16-18 |
| 10 | 532 18 45-05 | SPRING DEFLECT CHUTE |
| 11 | 581 69 75-01 | KNOB SOFT TOUCH SLOTTED |
| 12 | 501 41 74-01 | WASHER NYLON |
| NI | 580 94 77-05 | BAG PLASTIC 6.5 X 10.5 |
| | | WARNING |
| NI | 588 07 76-06 | KIT REPLACEMENT BAG OF PARTS |



| KEY NO. | PART NO. | DESCRIPTION |
|---------|---------------|---------------------|
| 1 | 532 19 30- 71 | SAFETY IGNITION KEY |

NOTE: All component dimensions given in U.S. inches. 1 inch = 25.4 mm
IMPORTANT: Use only Original Equipment Manufacturer (O.E.M.) replacement parts. Failure to do so could be hazardous, damage your snow thrower and void your warranty.

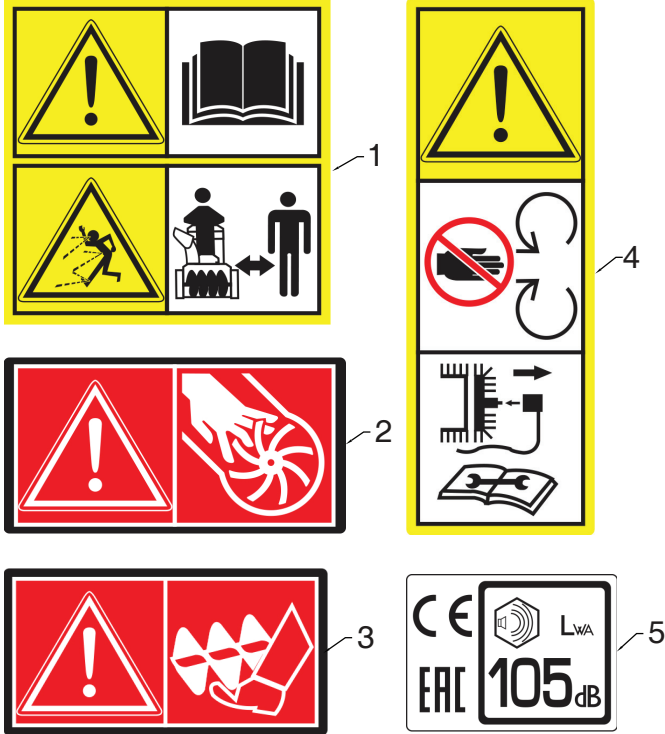

| KEY NO. | PART NO. | DESCRIPTION |
|---------|--------------|--------------------|
| 1 | 532 18 40-45 | DECAL AUGER |
| 2 | 532 19 96-82 | DECAL CHUTE |
| 3 | 532 19 96-83 | DECAL AUGER SAFETY |
| 4 | 532 18 40-28 | DECAL BELT GUIDE |
| 5 | 588 04 98-01 | DECAL NOISE LEVEL |

05.16.002-B

NOTE: All component dimensions given in U.S. inches. 1 inch = 25.4 mm
IMPORTANT: Use only Original Equipment Manufacturer (O.E.M.) replacement parts.
 Failure to do so could be hazardous, damage your snow thrower and void your warranty.

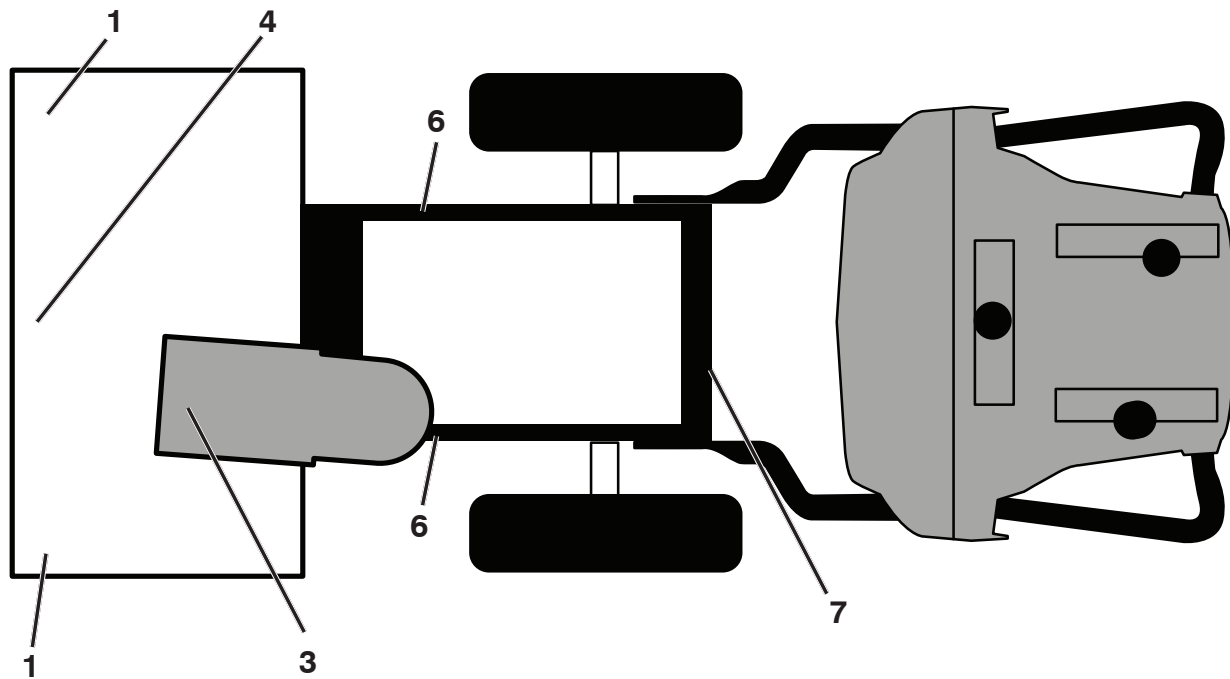

| KEY PART NO. | PART NO. | DESCRIPTION |
|--------------|--------------|---------------------------------|
| 1 | 532 19 96-83 | DECAL, DANGER READ OWNER'S |
| 3 | 532 19 96-82 | DECAL, DANGER, DEFLECTOR CHUTE |
| 4 | 532 18 40-45 | DECAL, DANGER AUGER |
| 6 | 532 18 40-28 | DECAL, INSTRUCTION BELT GUARD |
| 7 | 532 18 04-33 | DECAL, NOISE LEVEL 105DB/CE INT |
| -- | 115 82 78-20 | OPERATOR'S MANUAL, EURO |
| -- | 115 82 78-10 | OPERATOR'S MANUAL, SCAN |
| -- | 115 82 78-50 | OPERATOR'S MANUAL, EBLOC |
| -- | 115 82 78-40 | OPERATOR'S MANUAL, BALTIC |

NOTE: All component dimensions given in U.S. inches. 1 inch = 25.4 mm
IMPORTANT: Use only Original Equipment Manufacturer (O.E.M.) replacement parts. Failure to do so could be hazardous, damage your snow thrower and void your warranty.

