

ILLUSTRATED PARTS LIST

MODEL NO. 96041038200

CUST. CAT. NO. M145-107T POWERDRIVE

PRODUCT NO. 960 41 03-82

**TRACTOR -- MODEL NO. M145-107T (96041038200), PRODUCT NO. 960 41 03-82
DECALS 27**

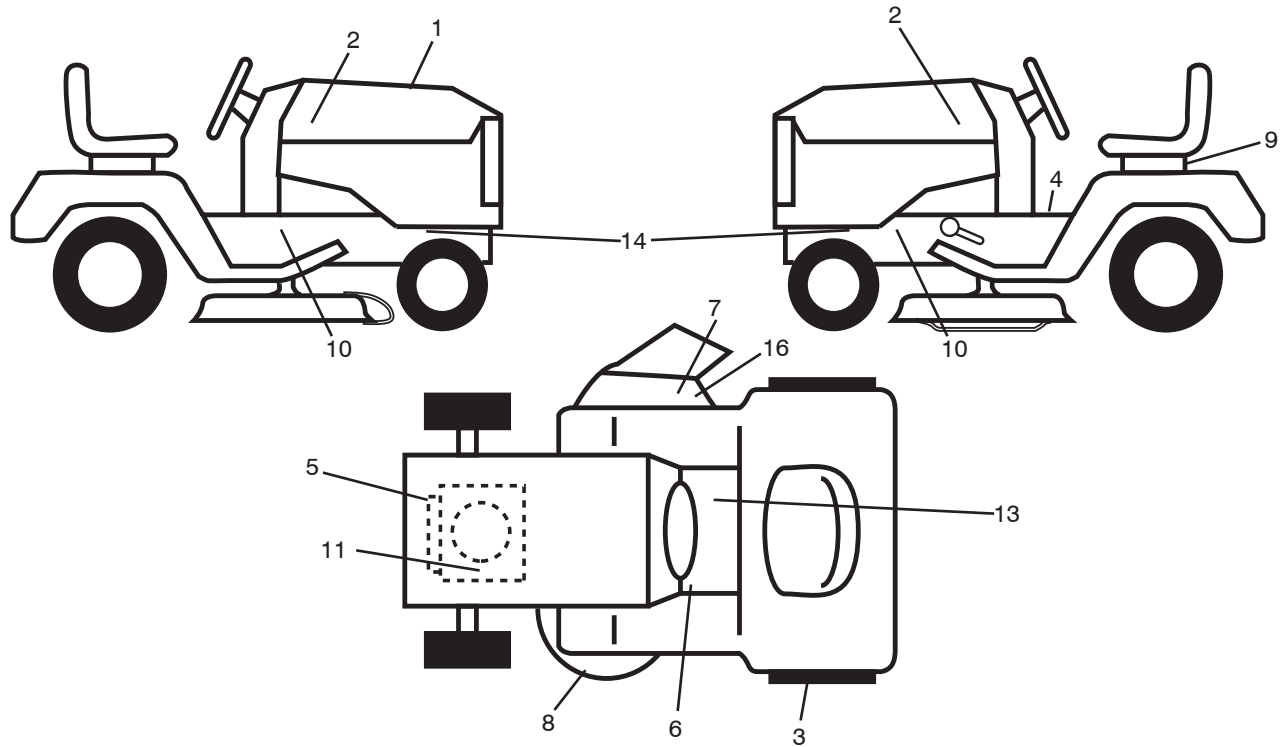

**KEY PART
NO. NO.**

DESCRIPTION

1	581 59 18-01	Decal, RPL.	13	581 57 80-01	Decal, Saddle Brake Parking
2	581 09 12-01	Decal, Hood LH/RH	14	581 57 98-01	Decal, Warning Service/Fire
3	581 92 56-01	Decal, Fender	16	581 57 92-01	Decal, Deflect Wrn. Cutfinger Sym
4	581 57 81-01	Decal, Oper/Wrng.	--	581 72 48-01	Decal, Bypass Fender
5	532 43 74-12	Decal, Engine HP	--	581 72 46-01	Decal, Drawbar Load Limit
6	581 72 40-01	Decal, Fender Brake Clutch	--	532 40 95-05	Pad, Footrest, LH
7	584 90 46-01	Decal, Deflect. Warning	--	532 40 95-07	Pad, Footrest, RH
8	581 58 00-01	Decal, V-Belt Schematic	--	588 91 60-01	Decal, Hood RCGSTRIP
9	532 14 50-05	Decal, Battery Dnge/Poi	--	588 22 86-40	Manual Oper. Euro
10	581 57 96-01	Decal, Chassis Hot Muffler	--	589 22 86-50	Manual Oper. Scan
11	581 57 97-01	Decal, Warning Eng Symbols	--	588 22 86-20	Manual Oper. E-Bloc
			--	588 22 86-30	Manual Oper. Baltic

WHEELS & TIRES

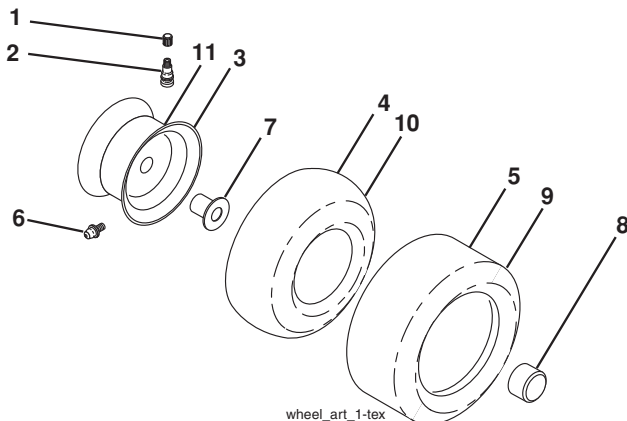

**KEY PART
NO. NO.**

DESCRIPTION

1	532 05 91-92	Cap, Valve, Tire
2	532 06 51-39	Stem, Valve
3	532 12 51-21	Rim Assembly, Front
4	532 05 99-04	Tube, Front
5	532 10 62-22	Tire, Front 15 x 6-6
6	532 12 49-57	Fitting, Grease
7	532 12 49-59	Bearing, Flange
8	532 19 32-68	Cap, Axle
9	532 12 46-35	Tire, Rear 18 x 8.5-8
10	532 12 49-26	Tube, Rear
11	532 12 51-22	Rim Assembly, Rear
--	532 14 43-34	Sealant, Tire (10 oz. Tube)

NOTE: All component dimensions given in U.S. inches
1 inch = 25.4 mm

TRACTOR - - MODEL NO. M145-107T (96041038200), PRODUCT NO. 960 41 03-82

SCHEMATIC **38**

SCH11

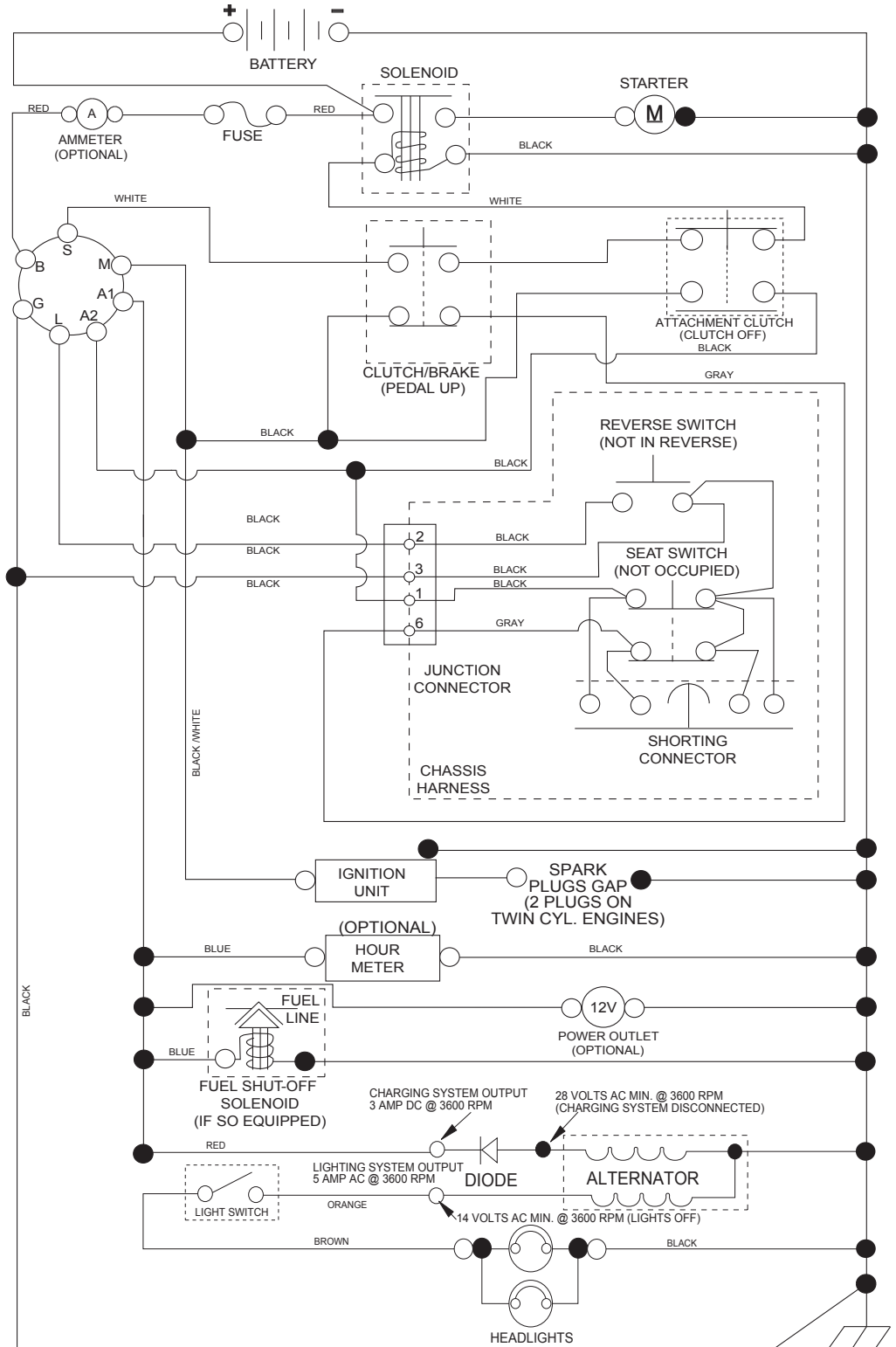

NOTE
YOUR TRACTOR IS EQUIPPED WITH A SPECIAL ALTERNATOR SYSTEM. THE LIGHTS ARE NOT CONNECTED TO THE BATTERY, BUT HAVE THEIR OWN ELECTRICAL SOURCE. BECAUSE OF THIS, THE BRIGHTNESS OF THE LIGHTS WILL CHANGE WITH ENGINE SPEED. AT IDLE THE LIGHTS WILL DIM. AS THE ENGINE IS SPEEDED UP, THE LIGHTS WILL BECOME THEIR BRIGHTEST.

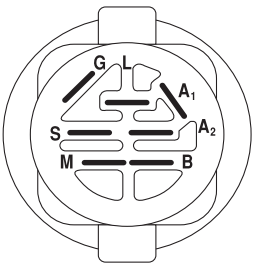

IGNITION SWITCH

POSITION	CIRCUIT	"MAKE"
OFF	M+G+A1	
RUN/OVERRIDE	B+A1	
RUN	B+A1	L+A2
START	B + S + A1	

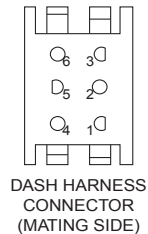
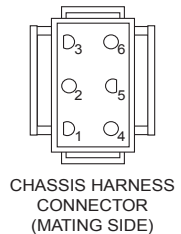

WIRING INSULATED CLIPS
NOTE: IF WIRING INSULATED CLIPS WERE REMOVED FOR SERVICING OF UNIT, THEY SHOULD BE RE-INSTALLED TO PROPERLY SECURE YOUR WIRING.

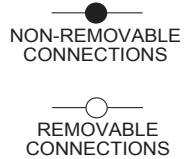

TRACTOR - - MODEL NO. M145-107T (96041038200), PRODUCT NO. 960 41 03-82
ELECTRICAL 32

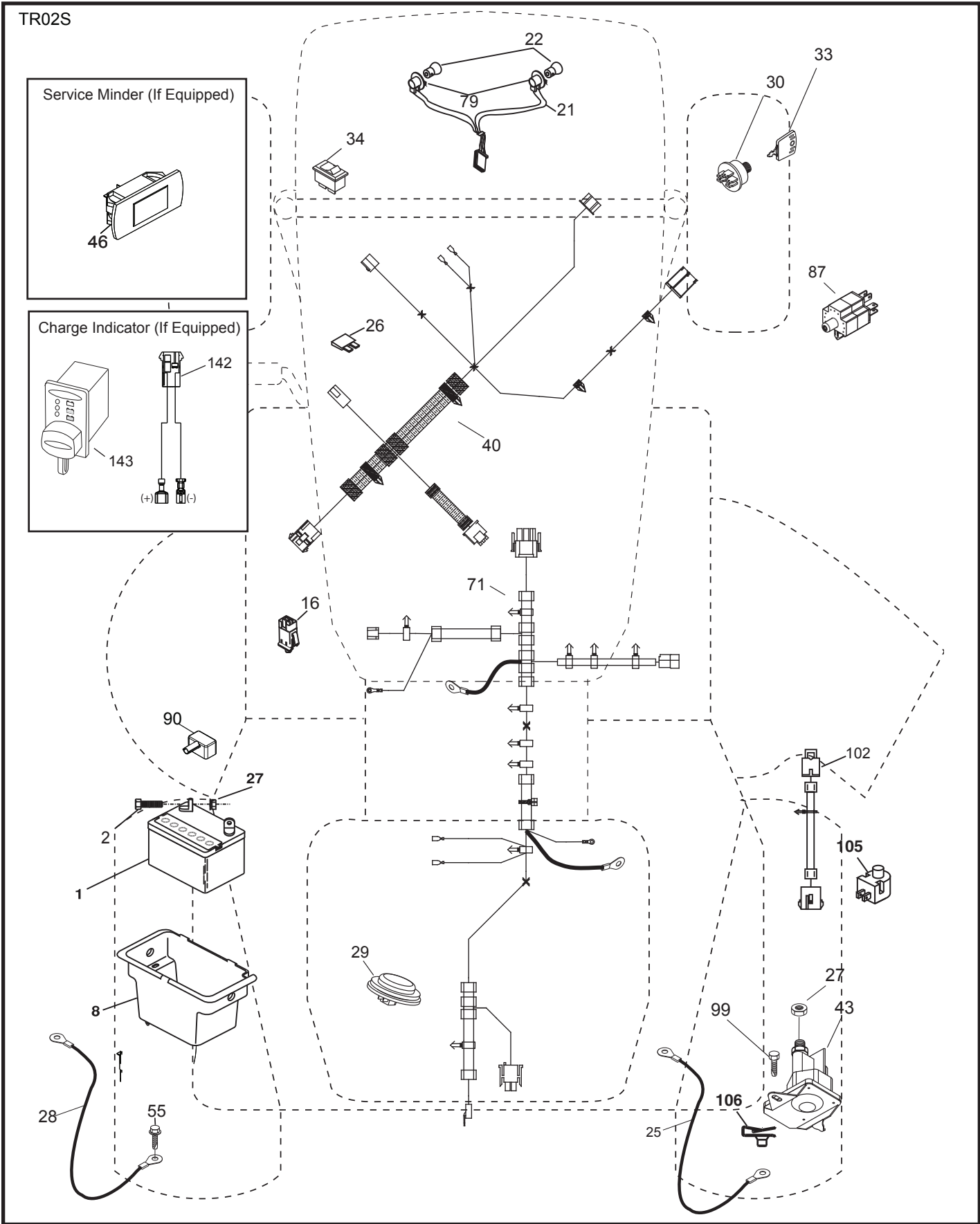

**TRACTOR - - MODEL NO. M145-107T (96041038200), PRODUCT NO. 960 41 03-82
ELECTRICAL 32**

KEY NO.	PART NO.	DESCRIPTION
1	532 16 34-65	Battery
2	874 76 04-12	Bolt Hex Head 1/4-20 x 3/4
8	532 19 32-28	Box Battery
16	532 17 61-38	Switch Interlock Push-In
21	532 40 02-52	Harness Socket Light w/4152J
22	532 00 41-52	Bulb Light
25	581 49 80-01	Cable Starter
26	532 17 51-58	Fuse
27	873 51 04-00	Nut Keps Hex 1/4-20 unc
28	532 42 16-86	Cable,Ground
29	532 40 15-45	Switch, Seat
30	532 19 33-50	Switch, Ign
33	532 41 19-35	Key/Chain
34	532 11 07-12	Switch Light/Reset
40	581 02 31-01	Harness Ign. Dash
43	532 19 25-07	Solenoid
55	817 06 05-12	Screw Thdrol 5/16-18 x 3/4 TYTT
71	501 13 37-01	Harness Ign. Chassis
79	532 17 52-42	Socket Asm
87	532 19 78-02	Switch Interlock Clutch Cbl
90	532 43 53-95	Cover Terminal
99	817 67 04-12	Screw 1/4-20 x 3/4
102	581 02 34-01	Harness Pigtail
105	532 40 75-68	Switch Reverse
106	532 17 48-14	Palnut 1/4 Lugs

NOTE: All component dimensions given in U.S. inches
1 inch = 25.4 mm

TRACTOR -- MODEL NO. M145-107T (96041038200), PRODUCT NO. 960 41 03-82
CHASSIS AND ENCLOSURES 39

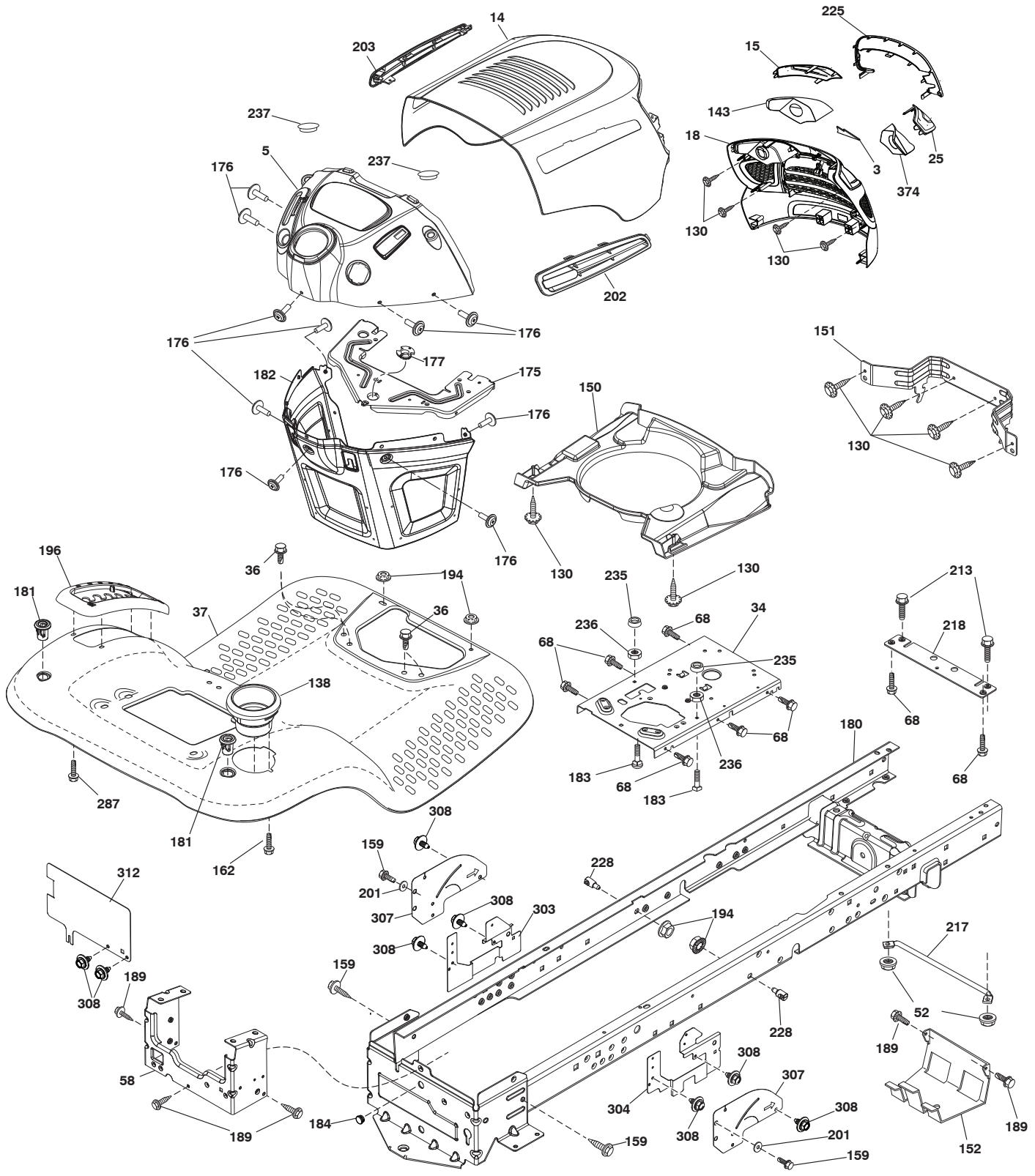

chassis-tex_TEX LT PRED_124

**TRACTOR - - MODEL NO. M145-107T (96041038200), PRODUCT NO. 960 41 03-82
CHASSIS AND ENCLOSURES **39****

KEY NO.	PART NO.	DESCRIPTION
3	578 89 71-01	Emblem Mount
5	532 40 95-97	Dash
14	581 56 47-01	Hood
15	581 05 58-01	Lens LH
18	581 05 57-01	Grille
25	581 05 59-01	Lens RH
34	580 91 08-01	Plate Engine
36	817 06 05-12	Screw 5/16-18 x 3/4
37	532 42 07-96	Fender
52	873 68 05-00	Nut lock 5/16-18
58	532 41 22-80	Drawbar, Upper 2 Pc.
68	817 49 05-08	Screw Thdrol. 5/16-18 x 1/2
130	532 41 63-58	Screw #10 x 0.750
138	532 40 97-30	Cupholder
143	581 05 60-01	Reflector Insert LH
150	532 40 02-67	Duct Heat Hood
151	532 18 75-68	Bracket Pivot
152	532 19 95-35	Shield Browning
159	817 00 06-12	Screw Hexwsh Thdr 3/8-16 x 3/4
162	532 14 24-32	Screw Hex Wsh. Hi-Lo 1/4 x 1/2
175	532 19 94-72	Crossmember
176	532 40 07-76	Screw 10-24 x 5/8 Wshd. Qdrx.
177	532 19 52-28	Bushing Steering
180	532 41 50-63	Chassis
181	532 40 47-96	Bushing Mtg. Fender Crgo.
182	532 40 71-76	Dash Lower
183	874 52 05-20	Bolt 5/16-18 x 1-1/4
184	587 55 41-01	Plug
189	817 00 05-12	Screw 5/16-18 x 3/4
194	873 90 05-00	Nut Lock Hex Flange 5/16-18
196	532 41 45-81	Console Asm. Deck Lift
201	819 13 20-16	Washer 13/32 x 1-1/4 x 16 Ga.
202	588 98 86-01	Vent Hood RH
203	588 98 86-02	Vent Hood LH
213	874 76 05-12	Bolt Hex Hd. 5/16-18 unc x 3/4
217	532 40 91-67	Rod Pivot Chassis
218	532 19 63-95	X-Piece Hood Stop
225	581 05 62-01	Trim Ring
228	532 19 51-61	Stud Fastener
235	532 40 61-29	Spacer Fender
236	873 93 05-00	Nut center Lock 5/16-18
237	532 40 37-04	Plug Mount Cargo
287	817 60 04-06	Screw 1/4-20 x 3/8
303	587 49 34-02	Shield Chassis French LH
304	587 86 51-02	Shield Chassis French RH
307	587 49 46-01	Shield Upper Pedal
308	532 17 18-77	Bolt 5/16-18 unc x 3/4
312	587 49 30-02	Shield Drawbar
374	581 05 60-02	Insert Reflector RH

NOTE: All component dimensions given in U.S. inches
1 inch = 25.4 mm

TRACTOR -- MODEL NO. M145-107T (96041038200), PRODUCT NO. 960 41 03-82
DRIVE **40**

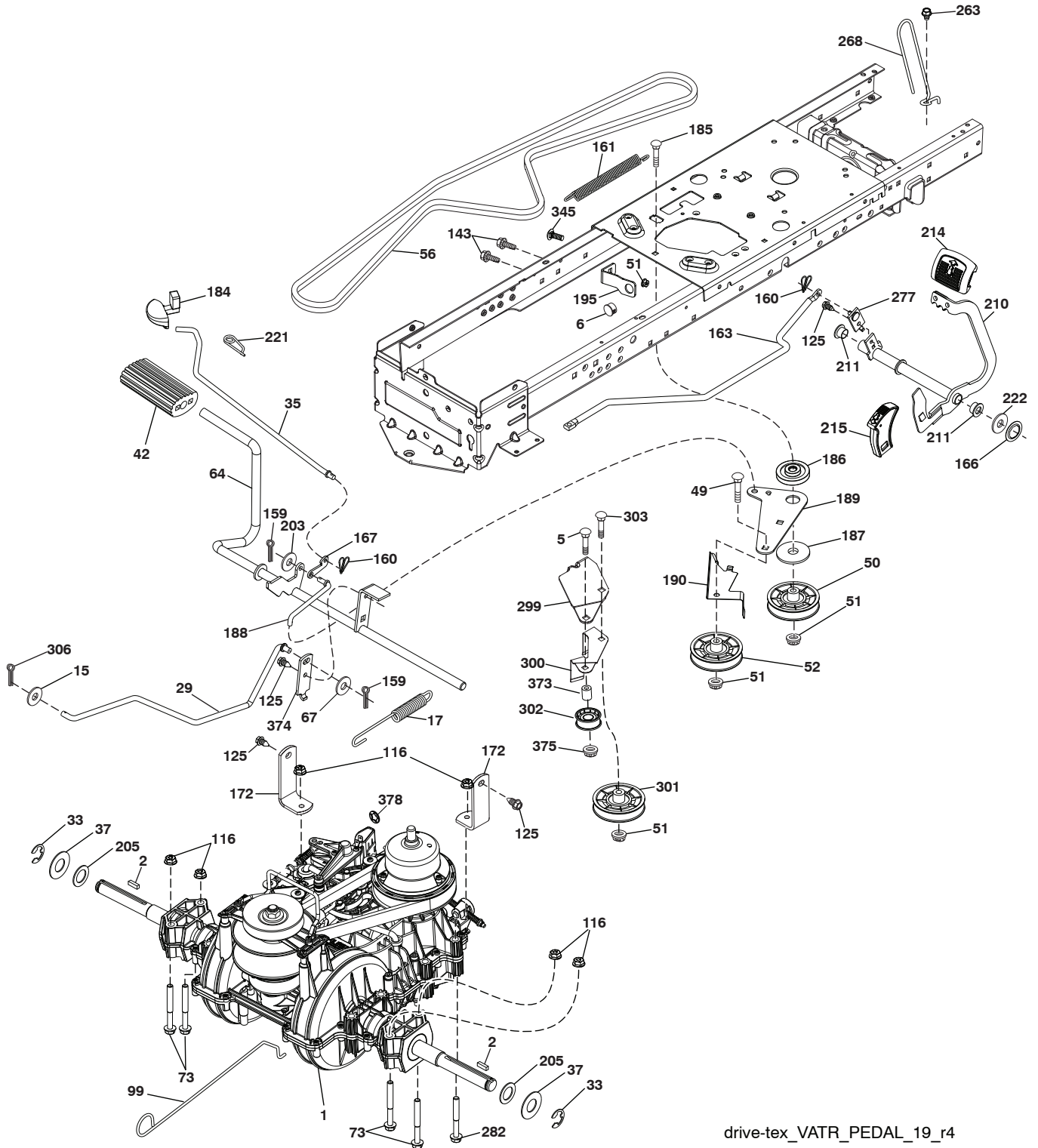

drive-tex_VATR_PEDAL_19_r4

**TRACTOR - - MODEL NO. M145-107T (96041038200), PRODUCT NO. 960 41 03-82
DRIVE **40****

KEY NO.	PART NO.	DESCRIPTION	KEY NO.	PART NO.	DESCRIPTION
1	---	Transaxle, Variator SD Pedal (584973901) (Order parts from transaxle manufacturer.)	186	532 19 43-21	Spacer Retainer
2	532 12 35-83	Key Square	187	819 13 32-10	Washer 13/32 x 2 x 10 ga
5	874 76 06-36	Bolt Hex Hs 3/8-16 unc x 2-1/4	188	582 21 70-01	Link Clutch Ground Drive, Long
6	532 12 40-28	Bushing Snap	189	532 19 43-17	Bellcrank Ground Drive
15	819 13 13-16	Washer 13/32 x 13/16 x 16 Ga.	190	532 19 43-18	Keeper. Bellcrank
17	501 48 71-01	Spring, Brake	195	581 50 46-01	Bracket Brake
29	584 82 31-01	Rod, Brake	203	819 11 11-16	Washer 11/32 x 11/16 x 16 Ga.
33	812 00 00-01	Ring E	205	532 12 17-48	Washer 25/32 x 1-5/8 16 Ga.
35	532 40 10-31	Rod, Brake, Park	210	532 44 82-70	Weldment Pedal VATR
37	532 18 89-67	Washer .793 x 1.637 x 060	214	532 42 12-63	Pedal Forward
42	532 12 48-72	Cover, Foot Pedal	215	532 44 82-54	Pad Pedal Reverse
49	872 11 06-14	Bolt 3/8-16 unc	211	532 12 01-83	Bearing Nylon
50	532 19 43-27	Idler Flat	221	532 40 31-87	Retainer Spring
51	873 90 06-00	Nut Lock 3/8-16 unc	222	879 21 20-10	Washer Flat
52	532 19 43-26	Idler V-Groove	263	817 00 06-12	Screw
56	581 60 38-01	V-Belt, Drive	268	532 18 24-02	Guard.Muffler
64	532 44 83-53	Subasm. Shaft Pedal Brake	277	532 44 85-00	Subasm. Link Rocker Pedal
67	582 58 01-01	Washer Nylon 13/32 x 13/16 x .109	282	874 49 05-48	Screw Thdrol 5/16-18 x 3
73	874 49 05-44	Bolt Hex 5/16-18 x 3.75	299	532 41 56-83	Bracket Mount
99	532 43 59-35	Rod Bypass	300	532 41 56-81	Keeper Idler
116	873 90 05-00	Nut Lock Hex Flange 5/16-18	301	532 41 56-80	Pulley Idler Groove
125	817 00 05-12	Screw 5/16-18 x 3/4	302	581 42 05-01	Puller Idler Flat
143	817 49 05-08	Screw Thdrol 5/16-18 x 1/2 TYTT	303	872 11 06-18	Bolt
159	876 02 04-12	Pin Cotter 1/8 x 3/4	306	876 02 04-16	Pin Cotter 1/8 x 1
160	532 16 94-84	Retainer Clip	345	872 11 06-06	Bolt 3/8-16 unc
161	532 10 57-09	Spring, Return, Clutch	373	581 46 18-01	Spacer Idler
163	587 84 79-01	Rod Control	374	581 47 52-01	Arm Control Brake
166	532 42 91-64	Nut Push .625	375	873 68 06-00	Nut Crownlock 3/8-16 unc
167	532 40 52-57	Latch Brake Parking	378	584 28 77-01	Nut Push 8 mm
172	583 97 42-01	Strap Torque			
184	532 41 14-84	Handle Park Brk.			
185	872 11 06-22	Bolt 3/8-16 unc x 2-3/4			

NOTE: All component dimensions given in U.S. inches
1 inch = 25.4 mm

**TRACTOR - - MODEL NO. M145-107T (96041038200), PRODUCT NO. 960 41 03-82
ENGINE 24**

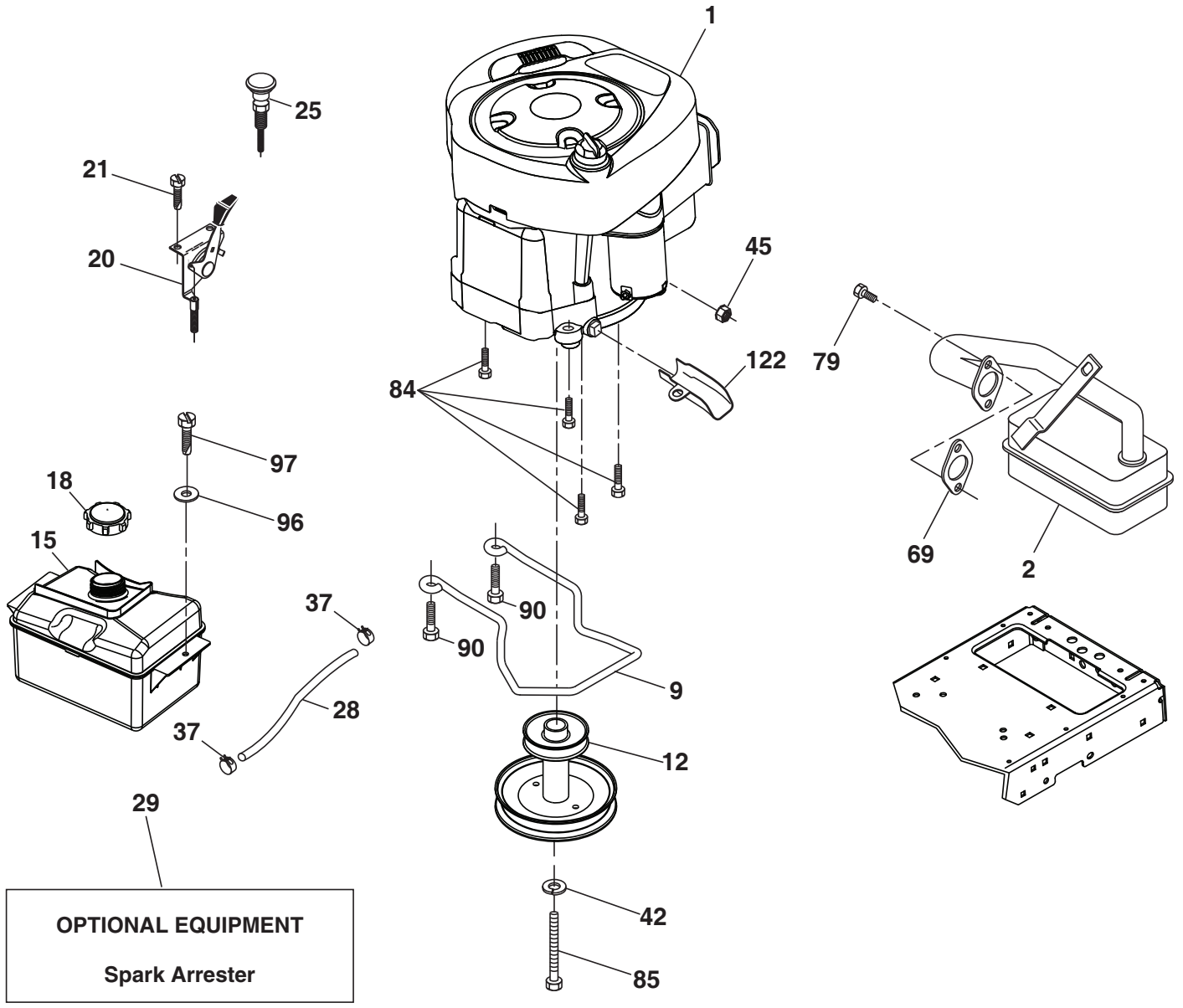

OPTIONAL EQUIPMENT
Spark Arrester

engine-tex_BS_112

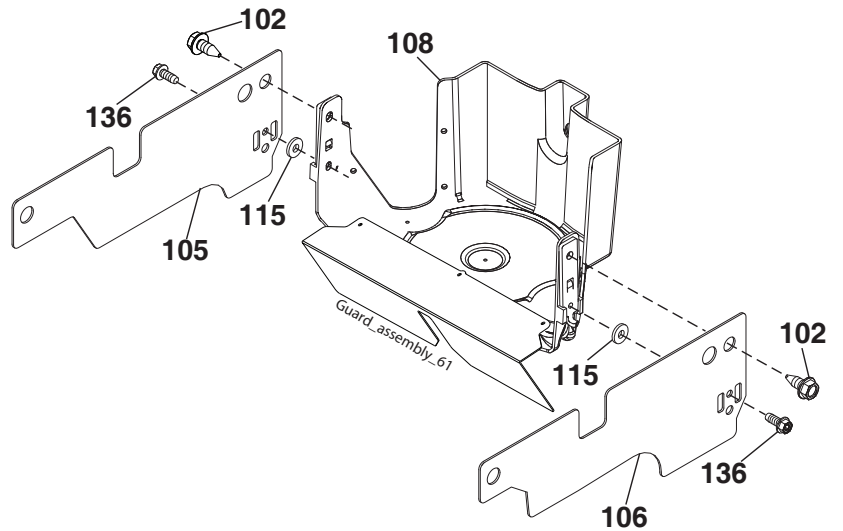

**TRACTOR - - MODEL NO. M145-107T (96041038200), PRODUCT NO. 960 41 03-82
ENGINE 24**

KEY NO.	PART NO.	DESCRIPTION
1	— — — — —	Engine B&S Model No. 31Q507-0002-H1 (585579801) (Order parts from engine manufacturer.)
2	532 13 73-52	Muffler
9	501 83 26-02	Keeper Belt Engine
12	586 47 85-01	Pulley Engine
15	581 28 99-01	Tank Fuel
18	532 43 02-20	Cap Fuel
20	532 18 38-97	Control Throttle/Choke
21	532 41 63-58	Screw #10 x 0.750
25	532 19 49-81	Choke Control
28	532 13 70-40	Fuel Line
29	532 13 71-80	Spark Arrester Kit
37	532 12 34-87	Clamp Hose
42	810 04 07-00	Washer Lock 7/16
45	873 51 04-00	Nut Keps Hex 1/4-20 unc
69	532 16 52-91	Gasket
79	532 19 23-34	Screw Socket Hd 5/16-18 x .75
84	817 06 06-20	Screw 3/8-16 x 1-1/4
85	532 17 39-37	Bolt Hex 7/16-20 x 4 x Gr. 5-1.5
90	817 00 06-16	Screw 3/8-16 x 1
96	819 09 14-16	Washer 9/32 x 7/8 x 16 Ga.
97	817 67 04-12	Screw 1/4-20 x 3/4
102	871 00 05-12	Screw 5/16-18 x 3/4
105	501 26 72-02	Shield Side LH
106	501 26 82-02	Shield Side RH
108	587 17 95-01	Cover Eng. Pulley w/SHLD 38", 42"
115	532 43 17-61	Palnut #10
122	532 42 19-22	Extension Drain Oil
136	532 42 17-56	Screw, #10 0.500, BOS

NOTE: All component dimensions given in U.S. inches
1 inch = 25.4 mm

Engine Power Rating Information

The gross power rating for individual gas engine models is labeled in accordance with SAE (Society of Automotive Engineers) code J1940 (Small Engine Power & Torque Rating Procedure), and rating performance has been obtained and corrected in accordance with SAE J1995 (Revision 2002-05). Torque values are derived at 3060 RPM; horsepower values are derived at 3600 RPM. Actual gross engine power will be lower and is affected by, among other things, ambient operating conditions and engine-to-engine variability. Given both the wide array of products on which engines are placed and the variety of environmental issues applicable to operating the equipment, the gas engine will not develop the rated gross power when used in a given piece of power equipment (actual "on-site" or net power). This difference is due to a variety of factors including, but not limited to, accessories (air cleaner, exhaust, charging, cooling, carburetor, fuel pump, etc.), application limitations, ambient operating conditions (temperature, humidity, altitude), and engine-to-engine variability. Due to manufacturing and capacity limitations, Briggs & Stratton may substitute an engine of higher rated power for this Series engine.

TRACTOR - - MODEL NO. M145-107T (96041038200), PRODUCT NO. 960 41 03-82
STEERING ASSEMBLY **41**

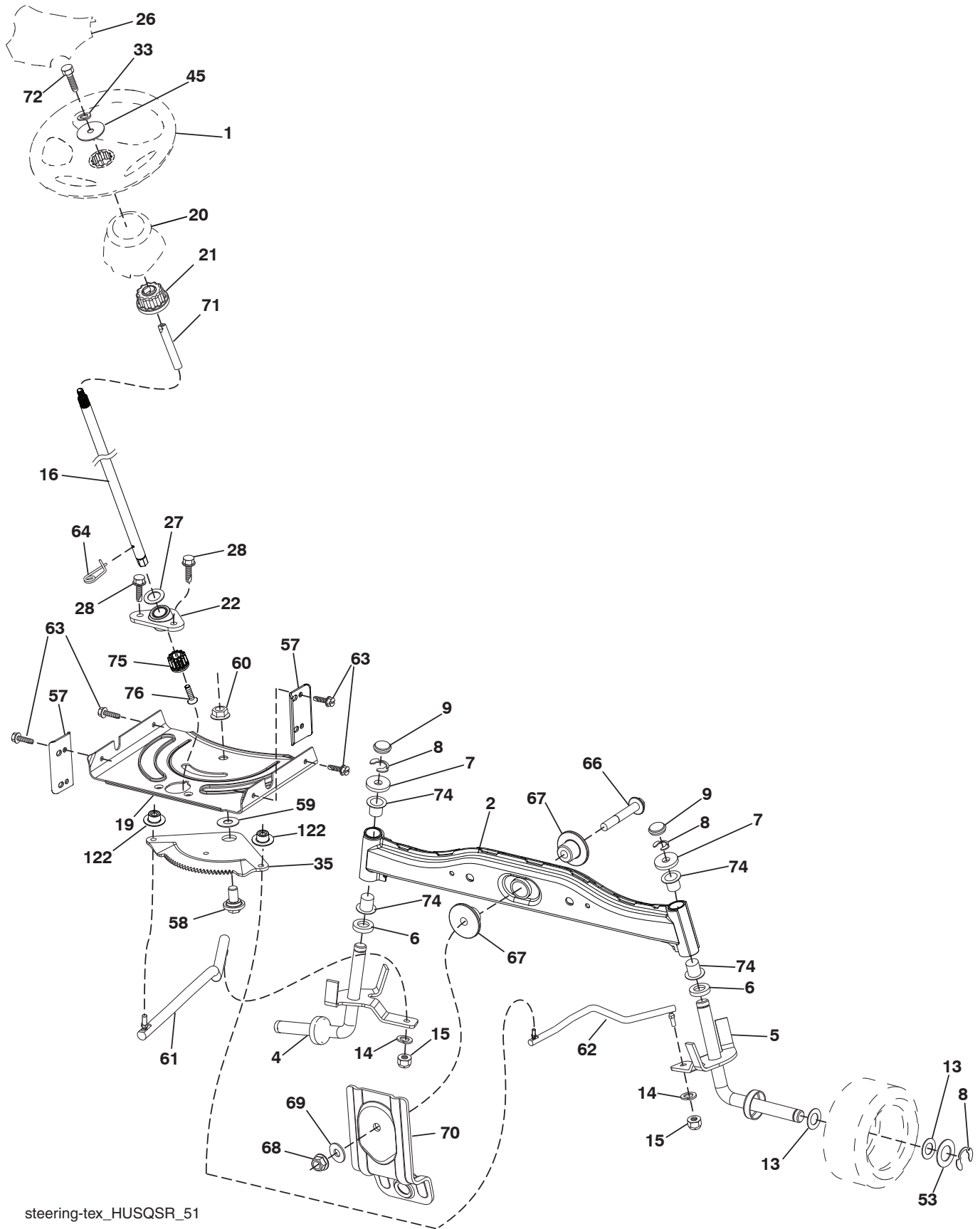

steering-tex_HUSQSR_51

**TRACTOR - - MODEL NO. M145-107T (96041038200), PRODUCT NO. 960 41 03-82
STEERING ASSEMBLY **41****

KEY PART NO.	PART NO.	DESCRIPTION
1	532 44 28-04	Wheel, Steering
2	532 41 81-68	Axle Asm., Front
4	532 40 30-87	Spindle Asm., LH
5	532 40 30-88	Spindle Asm., RH
6	532 12 49-31	Bearing, Race Thrust Harden
7	532 12 17-48	Washer 25/32 x 1-5/8 x 16 Ga.
8	812 00 00-29	Ring, Clip #T5304-75
9	532 12 12-32	Cap, Spindle
13	532 12 17-49	Washer 25/32 x 1-1/4 x 16 Ga.
14	810 04 06-00	Washer, Lock Hvy. Hlcl. Spr. 3/8
15	873 54 06-00	Nut, Crown Lock 3/8-24 unf
16	585 86 92-02	Steering Shaft
19	532 19 47-29	Plate Steering
20	532 40 97-63	Boot, Steering
21	532 18 67-37	Adapter, Wheel Steering
22	585 02 98-02	Bearing
26	532 44 77-59	Insert, Wheel Steering
27	819 21 16-16	Washer 21 x 32 x 1 x 16 Ga.
28	817 00 06-12	Screw 3/8-16 x 3/4
33	810 04 05-00	Washer Lock 5/16
35	532 19 47-32	Gear, Sector Plate
45	819 11 38-12	Washer 11/32 x 2-3/8 x 12 Ga.
53	532 18 89-67	Washer Hardened .793 x 1.637 x .060
57	532 40 74-65	Bracket Upstop
58	532 19 47-47	Bolt Shoulder Sector Pivot CFM
59	532 19 47-48	Washer Thrust Sector Steering
60	873 97 10-00	Nut Flange Lock 5/8-11
61	532 19 47-40	Draglink LH
62	532 19 47-41	Draglink, RH
63	817 00 05-12	Screw 5/16-18 x 3/4
64	532 19 98-49	Retainer Clip Spring Steering
66	871 02 07-48	Bolt Hex Fghd. 7/16-14 x 3 Serr.
67	532 19 47-37	Bushing PM Front Axle
68	873 90 07-00	Nut Lock Flange 7/16-14 Gr. 5
69	532 19 91-62	Washer 1.5 x .505 x .118
70	585 33 88-01	Bracket Deck Susp. Front
71	532 19 07-52	Shaft Ext. Steering
72	532 42 89-82	Bolt 5/16-18 x 4 w/Patch
74	532 12 49-37	Bearing
75	580 68 37-01	Pinion
76	580 68 36-01	Screw Head Sock
122	532 44 49-62	Cap Gear Sector

NOTE: All component dimensions given in U.S. inches
1 inch = 25.4 mm

TRACTOR - - MODEL NO. M145-107T (96041038200), PRODUCT NO. 960 41 03-82
MOWER DECK **44**

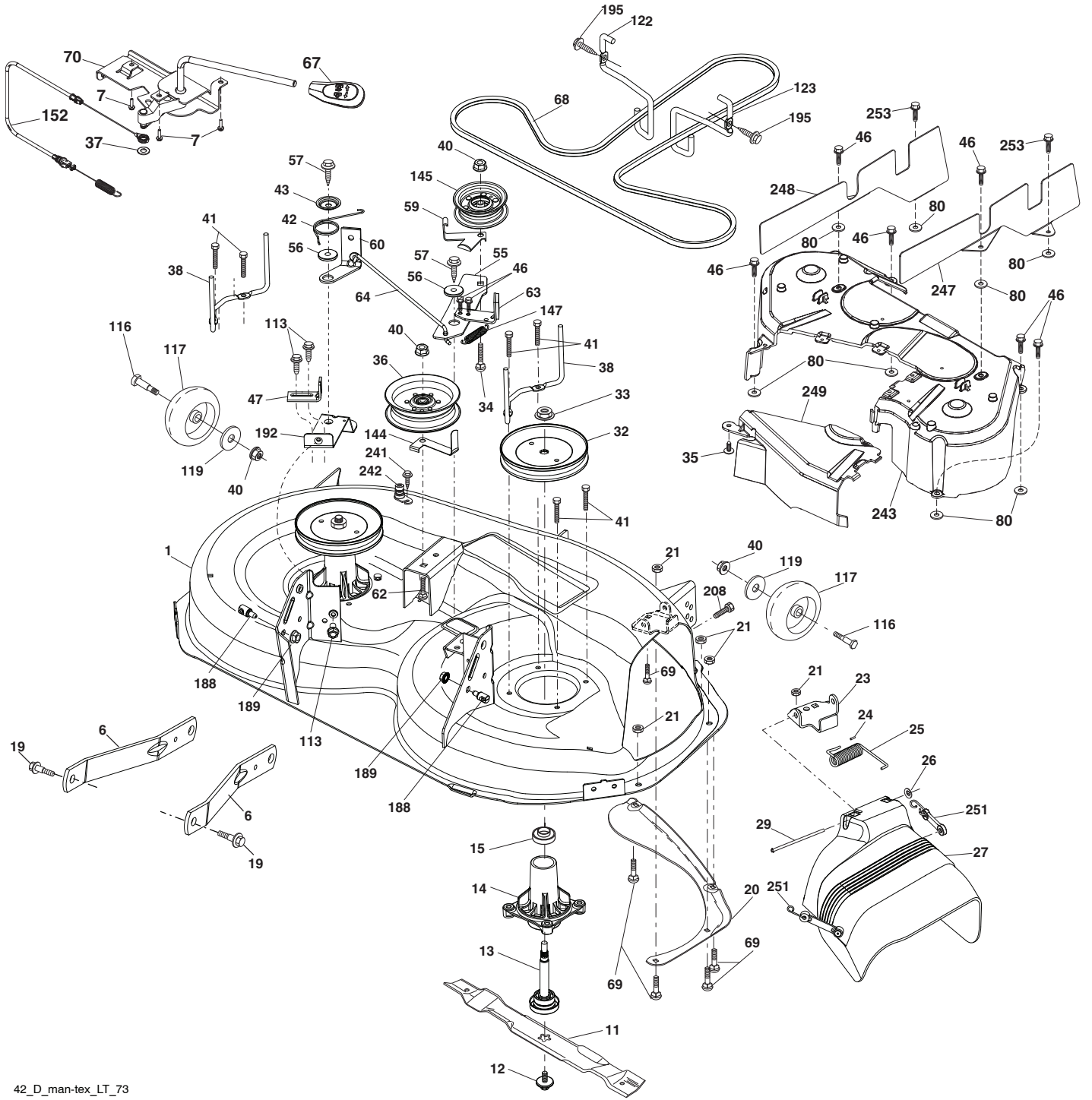

42_D_man-tex_LT_73

**TRACTOR - - MODEL NO. M145-107T (96041038200), PRODUCT NO. 960 41 03-82
MOWER DECK 44**

KEY NO.	PART NO.	DESCRIPTION	KEY NO.	PART NO.	DESCRIPTION
1	532 19 64-95	Mower Housing	68	532 42 96-36	V-Belt
6	532 19 51-86	Arm Suspension	69	872 14 05-05	Bolt Rdhd. Sqnk. 5/16-18 x 5/8
7	532 41 63-58	Screw #10 x 0.750	70	532 40 12-46	Clutch Asm. Manual
11	532 13 89-71	Blade, 42" Hi-Lift (For bagging or discharge)	80	532 42 30-62	Palnut 1/4
12	584 30 93-01	Screw Sems 7/16-20 x 1 Hx Hd	113	817 00 05-10	Screw 5/16-18
13	587 25 65-01	Shaft Assembly, Mandrel	116	532 12 48-42	Bolt, Shoulder
14	532 18 72-81	Housing, Mandrel	117	532 18 86-06	Wheel, Gauge
15	585 32 39-01	Bearing, Ball, Mandrel	119	819 12 14-14	Washer 13/32 x 7/8 x 14 Ga.
19	532 19 65-39	Bolt, Shoulder	122	532 19 72-58	Keeper Belt Eng. LH
20	532 15 97-70	Baffle, Vortex	123	532 19 72-59	Keeper Belt Eng. RH
21	873 68 05-00	Nut Crown Lock 5/16-18	144	532 19 92-04	Keeper Belt
23	532 19 25-57	Bracket, Deflector	145	532 19 31-97	Pulley, Idler, Flat
24	532 10 53-04	Cap, Sleeve	147	532 40 19-71	Spring Return
25	532 19 70-26	Spring, Torsion, Deflector	152	584 24 35-01	Cable Mechanical Clutch
26	532 11 04-52	Nut, Push	188	532 19 51-61	Stud Fastener
27	532 41 14-85	Shield, Deflector	189	873 90 05-00	Nut Lock Hex Flange
29	532 13 14-91	Rod, Hinge	192	532 19 72-60	Bracket Brake Stand LH
32	532 19 74-73	Pulley, Mandrel	195	817 00 06-12	Screw Hex Wsh. Thdrol. 3/8-16x3/4
33	532 40 02-34	Nut, Toplock, Flanged	208	817 67 06-08	Screw Thdrol 3/8-16 x 1/2
34	872 11 06-12	Bolt Carr. Sh. 3/8-16 x 1-1/2 Gr. 5	241	532 15 29-27	Screw
35	532 13 38-35	Fastener	242	532 41 55-98	Port Washout
36	532 19 73-79	Pulley Idler	243	532 43 23-94	Cover Deck 42"
37	819 13 13-16	Washer 13/32 x 13/16 x 16 Ga.	247	532 43 02-61	Shield Deck RH
38	532 43 25-20	Keeper Belt Mandrel	248	532 43 02-60	Shield Deck LH
40	873 90 06-00	Nut, Lock Flg. 3/8-16 unc	249	532 40 65-14	Cover Cable Clutch
41	584 95 39-01	Bolt Hex Wash HD .313-18 x 1.19	251	532 43 60-87	Kit Strap Bungee
42	532 19 84-10	Spring Trosion Brake	253	532 42 73-50	Rivot Tuflock
43	532 19 72-56	Spring Torsion Retainer	--	587 25 33-01	Mandrel Assembly (Includes housing (key #14), shaft assembly (key #13) and bearing only (key #15) - Pulley/Nut/Washer and Blade Bolt/Washers not included)
46	532 13 77-29	Screw Thdrol. 1/4-20 x 5/8	--	532 43 77-30	Replacement Mower, Complete
47	532 19 72-50	Bracket Clutch Cable			
55	532 43 71-10	Arm, Idler			
56	532 19 90-92	Spacer, Retainer			
57	817 00 06-16	Screw Hex Wsh. Thd. 3/8-16 x 1			
59	532 14 10-43	Guard, Tuv. Idler (94)			
60	532 19 72-61	Arm Brake Mower			
62	872 11 06-16	Bolt Rdhd. Sqnk. 3/8-16 unc x 2			
63	532 19 94-77	Arm Brake Mower			
64	532 19 97-90	Linkage Brake			
67	532 40 30-12	Handle, Clutch Cable			

NOTE: All component dimensions given in U.S. inches
1 inch = 25.4 mm

TRACTOR - - MODEL NO. M145-107T (96041038200), PRODUCT NO. 960 41 03-82
MOWER LIFT 45

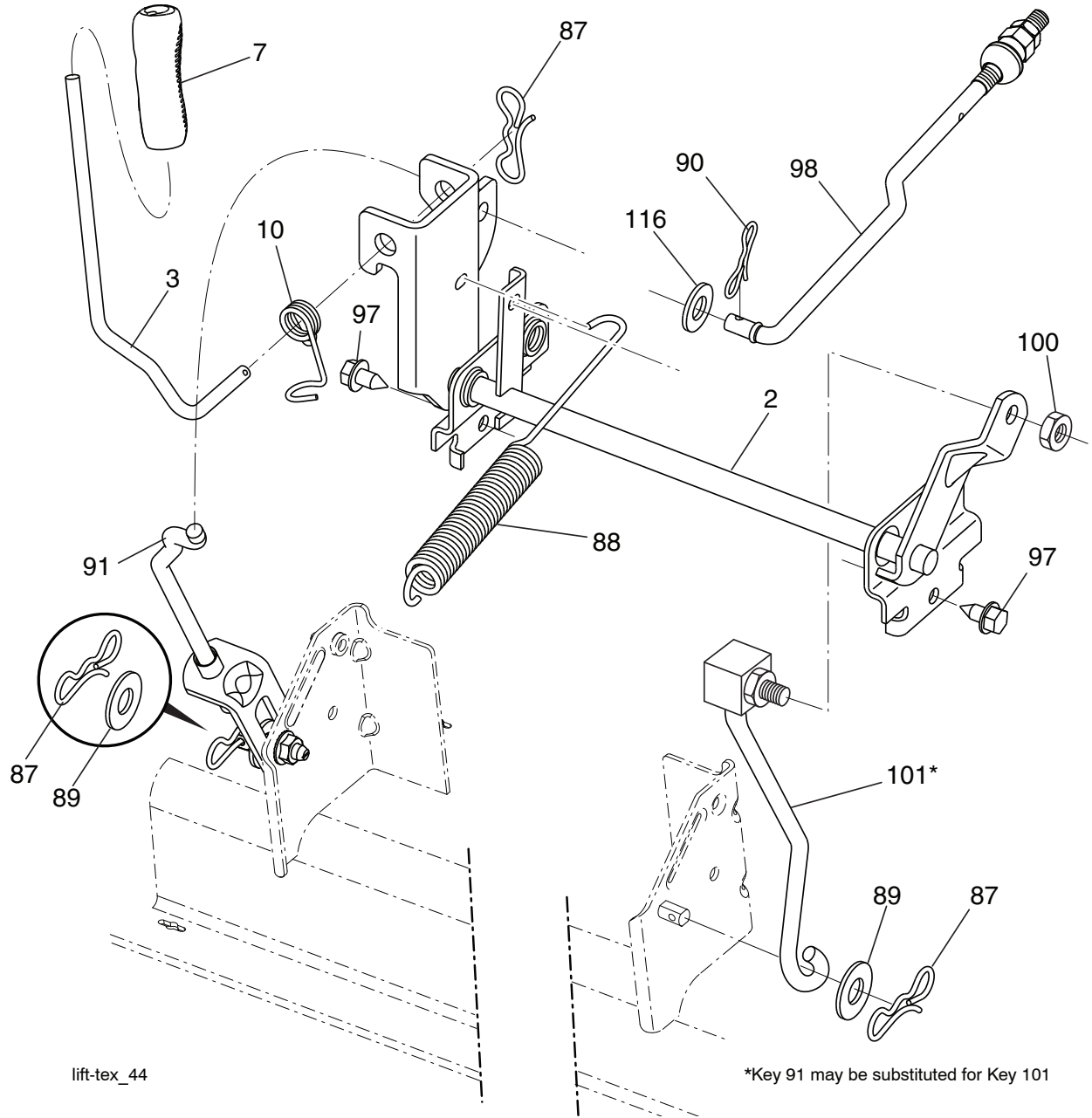

KEY NO.	PART NO.	DESCRIPTION
2	532 42 20-27	Shaft Asm., Cross Lift
3	532 19 52-31	Lever Asm., Lift RH
7	580 96 23-01	Grip, Lever
10	532 19 63-14	Spring Torsion
87	532 19 42-09	Pin Cotter 7/16 Bow Tie Lock
88	532 41 07-10	Spring Lift Assist
89	819 19 19-12	Washer Clear Zinc
90	532 19 42-08	Pin Cotter 5/16 Bow Tie Lock

KEY NO.	PART NO.	DESCRIPTION
91	532 19 51-81	Link Lift Susp. Mower Rear
97	817 00 06-12	Screw 3/8-16 x 3/4
98	532 19 52-70	Link Lift Susp. Front Mower
100	873 93 06-00	Nut Centerlock 3/8-16 unc
101	532 40 70-03	Link Asm Lift Fixed
116	819 15 15-16	Washer 15/32 x 15/16 x 16 Ga.

NOTE: All component dimensions given in U.S. inches
 1 inch = 25.4 mm

**TRACTOR - - MODEL NO. M145-107T (96041038200), PRODUCT NO. 960 41 03-82
SEAT ASSEMBLY 42**

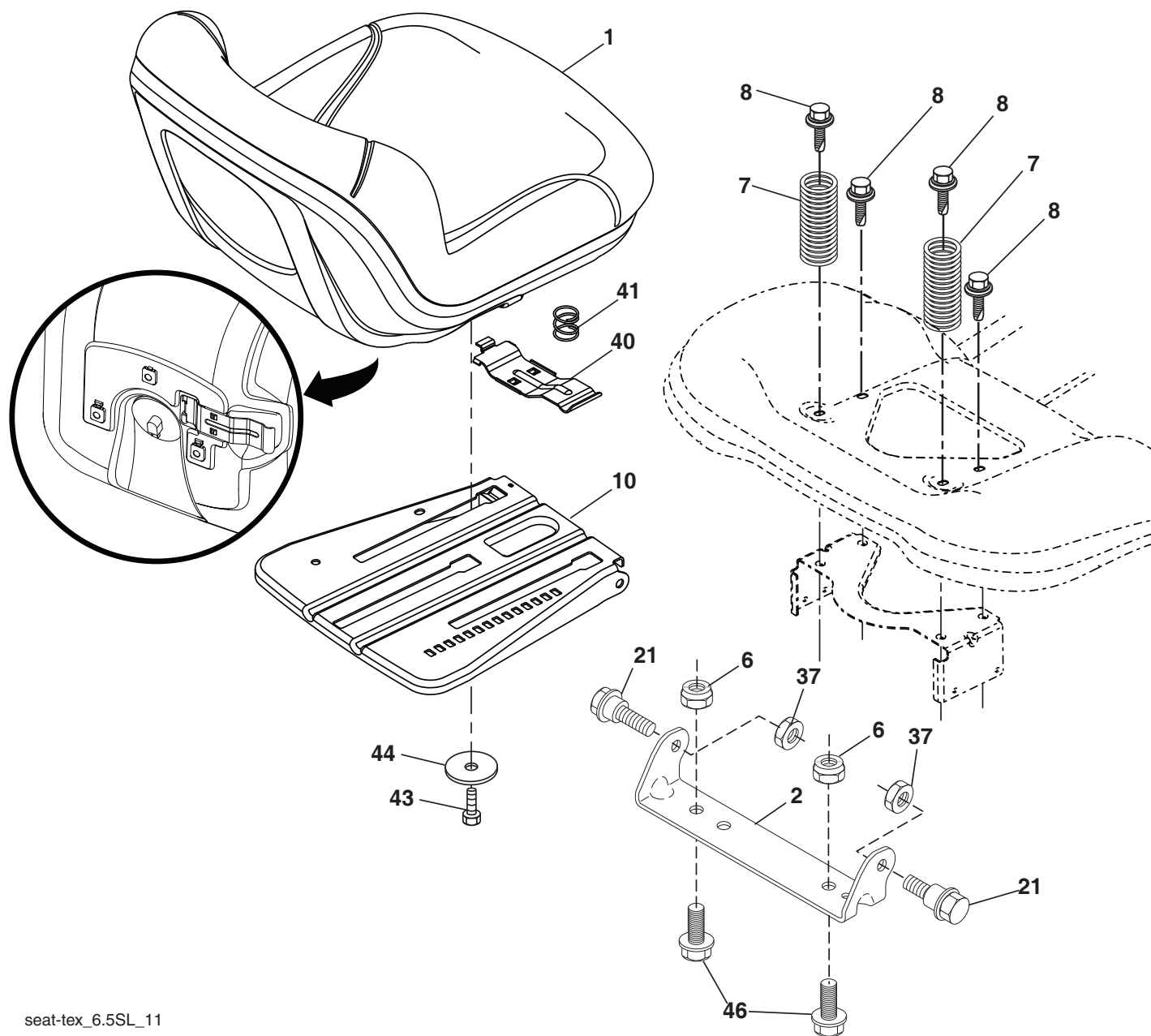

seat-tex_6.5SL_11

KEY NO.	PART NO.	DESCRIPTION
1	581 46 21-01	Seat
2	532 18 01-66	Bracket Pivot Fender
6	873 80 06-00	Nut, Lock w/Ins. 3/8-16 unc
7	587 61 33-01	Spring, Seat Cprsn.
8	532 17 18-77	Bolt 5/16-18 unc x 3/4 w/Sems.
10	532 19 69-77	Pan, Seat
21	587 90 78-01	Bolt, Shoulder 5/16-18 x 5/8
37	873 80 05-00	Nut, Lock 5/16-18 unc
40	532 19 76-61	Handle Slide Seat

KEY NO.	PART NO.	DESCRIPTION
41	532 19 82-00	Spring Latch Seat
43	874 76 06-12	Bolt 3/8-16 unc x 3/4
44	819 13 38-12	Washer 13/32 x 2-3/8 x 12 Ga.
46	588 09 04-01	Bolt 3/8-16 x 1, 1.25 OD

NOTE: All component dimensions given in U.S. inches
1 inch = 25.4 mm

