

ILLUSTRATED PARTS LIST

MFG. ID NO. 96041028702

CUSTOMER CATALOG NO. M115-77T

PROD. NO. 960 41 02-87

**TRACTOR - - MODEL NO. M115-77T (96041028702), PROD. NO. 960 41 02-87
DECALS 27**

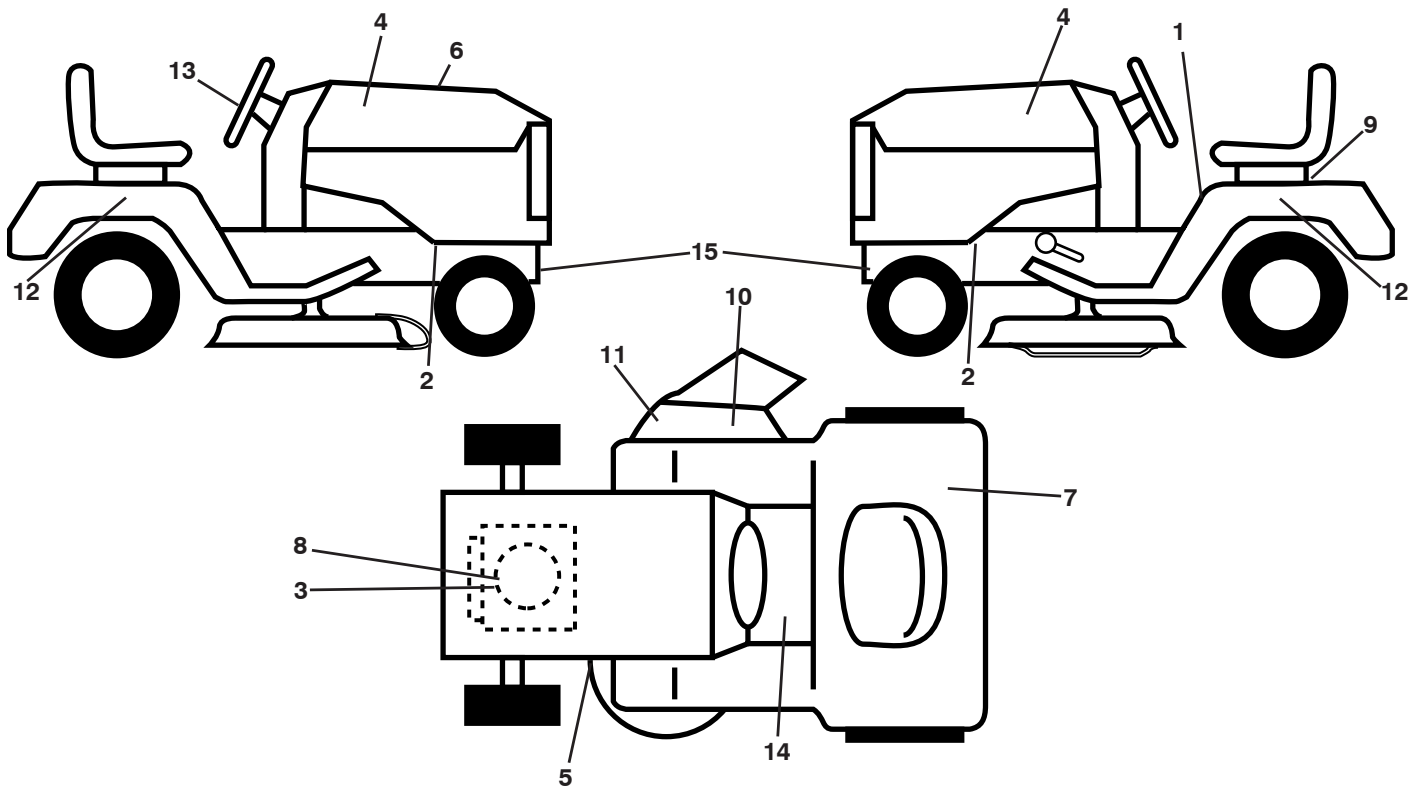

KEY NO.	PART NO.	DESCRIPTION
1	581 57 81-01	Decal, Read
2	581 57 96-01	Decal, Hot Muffler
3	581 57 97-01	Decal, Warning Engine Symbols
4	581 09 12-01	Decal, Hood RH/LH
5	581 58 00-04	Decal, V-Belt Schematic
6	532 44 32-40	Decal, Replacement
7	581 57 80-01	Decal, Parking Brake
8	532 43 74-09	Decal, Engine HP
9	532 14 50-05	Decal, Battery Dnge/Poi
10	584 90 46-01	Decal, Deck/Deflect. Warning
11	581 57 93-01	Decal, Warning

KEY NO.	PART NO.	DESCRIPTION
12	581 60 43-01	Decal, SDFNDR
13	501 49 43-01	Decal, SDFNDR
14	581 72 40-01	Decal, Brake/Clutch Symbol
15	581 57 98-01	Decal, Warning
--	581 72 46-01	Decal, Load Limit
--	532 40 95-05	Pad, Footrest, LH
--	532 41 12-73	Pad, Footrest, RH
--	588 74 57-20	Manual, Operator's (Euro)
--	588 74 57-10	Manual, Operator's (Scan)
--	588 74 69-50	Manual, Operator's (Ebloc)
--	588 74 70-40	Manual, Operator's (Baltic)

WHEELS AND TIRES

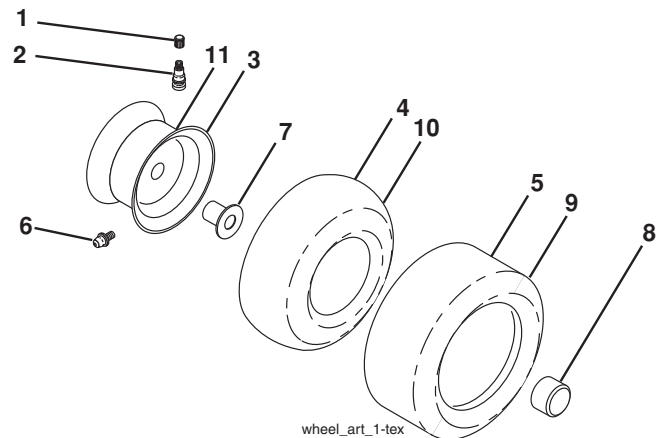

KEY NO.	PART NO.	DESCRIPTION
1	532 05 91-92	Cap Valve Tire
2	532 06 51-39	Stem Valve
3	532 42 53-61	Rim Asm 6" x 3.25 Front
4	532 42 16-52	Tube Front (Service Item Only)
5	532 12 34-10	Tire Front 13 x 5-6
6	532 12 49-57	Fitting Grease (Front Wheel Only)
7	532 12 49-59	Bearing Flange (Front Wheel Only)
8	532 19 32-68	Cap Axle Blk 1 50 x 1 00
9	532 10 62-30	Tire Rear 16 x 6.5-8
10	532 00 71-54	Tube Rear (Service Item Only)
11	532 42 53-62	Rim Asm 8" x 5.375 Rear
--	532 14 43-34	Sealant, Tire (10 oz. Tube)

NOTE: All component dimensions given in U.S. inches
1 inch = 25.4 mm

TRACTOR - - MODEL NO. M115-77T (96041028702), PROD. NO. 960 41 02-87

SCHEMATIC 38

SCH11

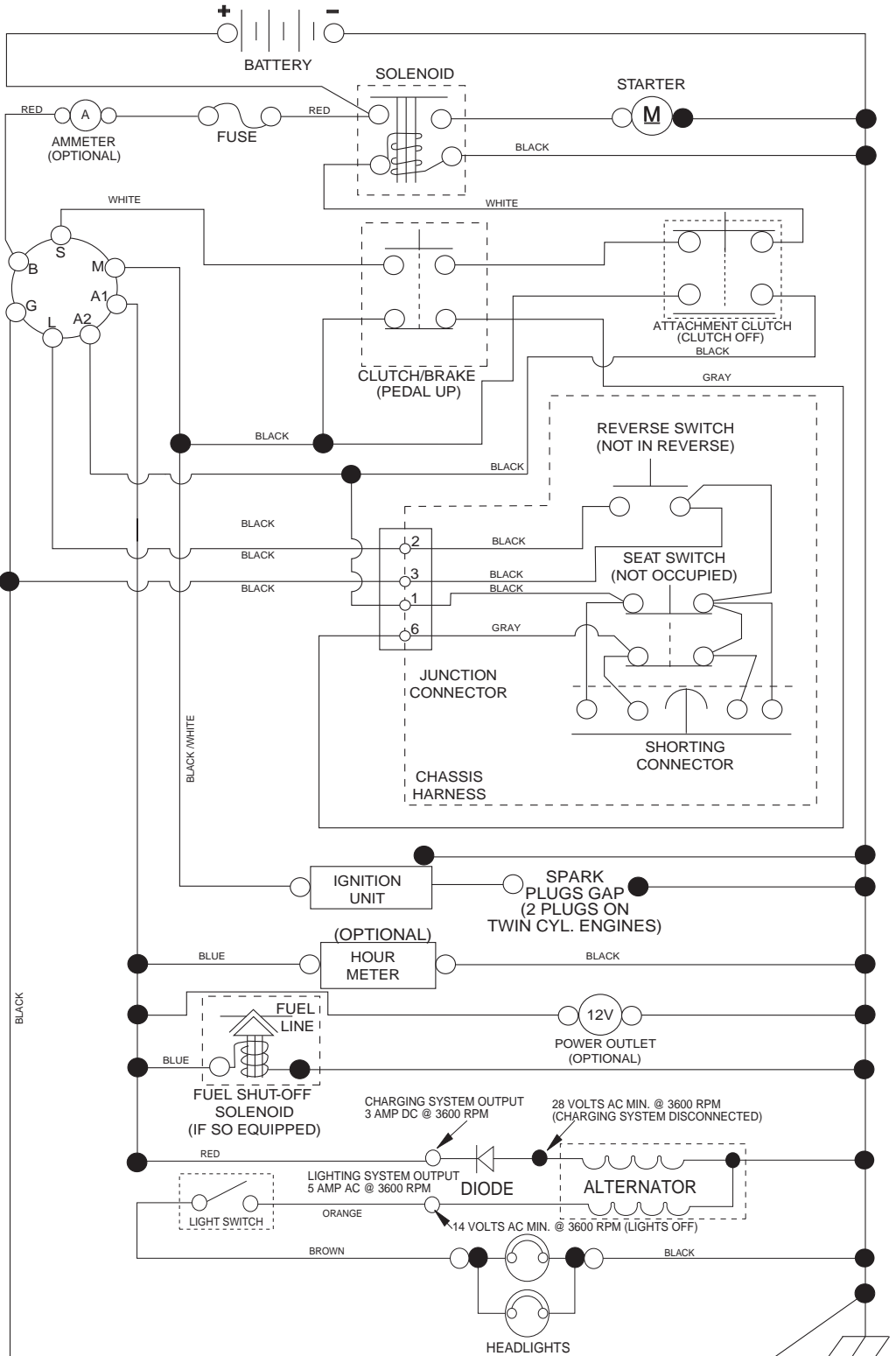

NOTE
 YOUR TRACTOR IS EQUIPPED WITH A SPECIAL ALTERNATOR SYSTEM. THE LIGHTS ARE NOT CONNECTED TO THE BATTERY, BUT HAVE THEIR OWN ELECTRICAL SOURCE. BECAUSE OF THIS, THE BRIGHTNESS OF THE LIGHTS WILL CHANGE WITH ENGINE SPEED. AT IDLE THE LIGHTS WILL DIM. AS THE ENGINE IS SPEEDED UP, THE LIGHTS WILL BECOME THEIR BRIGHTEST.

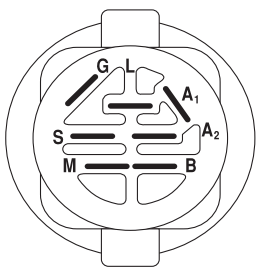

IGNITION SWITCH

POSITION	CIRCUIT "MAKE"
OFF	M+G+A1
RUN/OVERRIDE	B+A1
RUN	B+A1 L+A2
START	B+S+A1

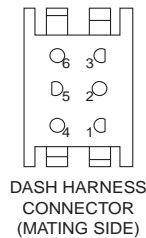
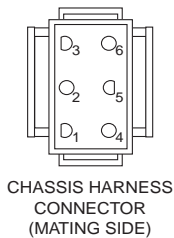

WIRING INSULATED CLIPS
 NOTE: IF WIRING INSULATED CLIPS WERE REMOVED FOR SERVICING OF UNIT, THEY SHOULD BE RE-INSTALLED TO PROPERLY SECURE YOUR WIRING.

NON-REMOVABLE CONNECTIONS
 REMOVABLE CONNECTIONS

TRACTOR - - MODEL NO. M115-77T (96041028702), PROD. NO. 960 41 02-87
ELECTRICAL 32

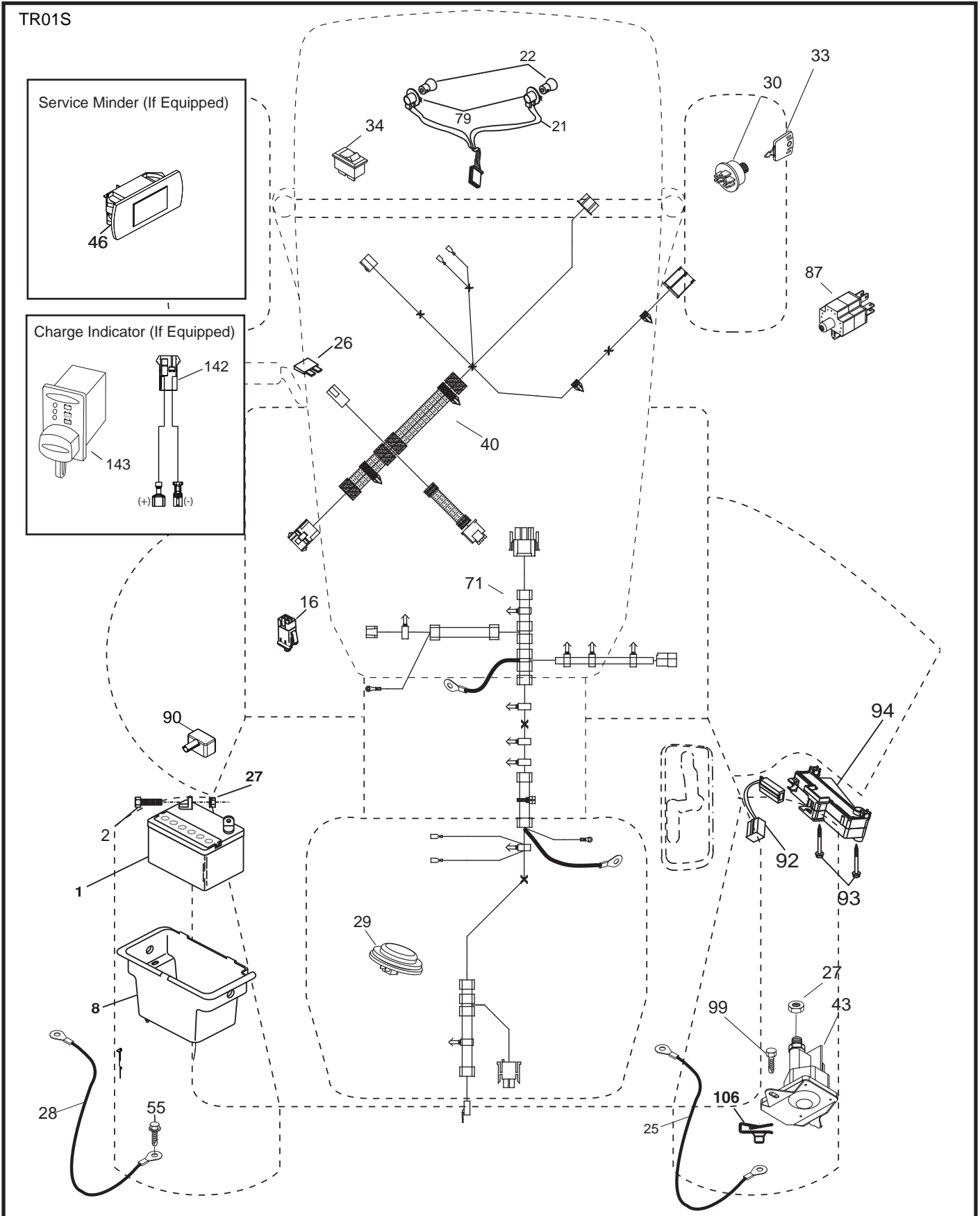

**TRACTOR - - MODEL NO. M115-77T (96041028702), PROD. NO. 960 41 02-87
ELECTRICAL 32**

KEY NO.	PART NO.	DESCRIPTION
1	532 14 49-24	Battery
2	874 76 04-12	Bolt Hex Head 1/4-20 x 3/4
8	532 19 32-28	Box Battery
16	532 17 61-38	Switch Interlock Push-In
21	532 40 02-52	Harness Socket Light w/4152J
22	532 00 41-52	Bulb Light
25	581 49 80-01	Cable Starter
26	532 17 51-58	Fuse
27	873 51 04-00	Nut Keps Hex 1/4-20 unc
28	532 42 16-86	Cable, Ground
29	532 40 15-45	Switch, Seat
30	532 19 33-50	Switch, Ign
33	532 41 19-35	Key/Chain
34	532 11 07-12	Switch Light/Reset
40	581 02 31-01	Harness Ign. Dash
43	532 19 25-07	Solenoid
55	817 06 05-12	Screw Thdrol 5/16-18 x 3/4
71	501 13 37-01	Harness Chassis
79	532 17 52-42	Socket Asm Bulb Twistlock
87	532 19 78-02	Switch Interlock Clutch Cable
90	532 43 53-95	Cover, Terminal Battery
92	532 19 66-15	Harness Pigtail
93	532 19 25-40	Screw Plastite 10-14-2.0
94	532 19 18-34	Module Reverse
99	817 67 04-12	Screw 1/4-20 x 3/4
106	532 17 48-14	Palnut 1/4 Lugs

NOTE: All component dimensions given in U.S. inches
1 inch = 25.4 mm

TRACTOR - - MODEL NO. M115-77T (96041028702), PROD. NO. 960 41 02-87
CHASSIS AND ENCLOSURES 39

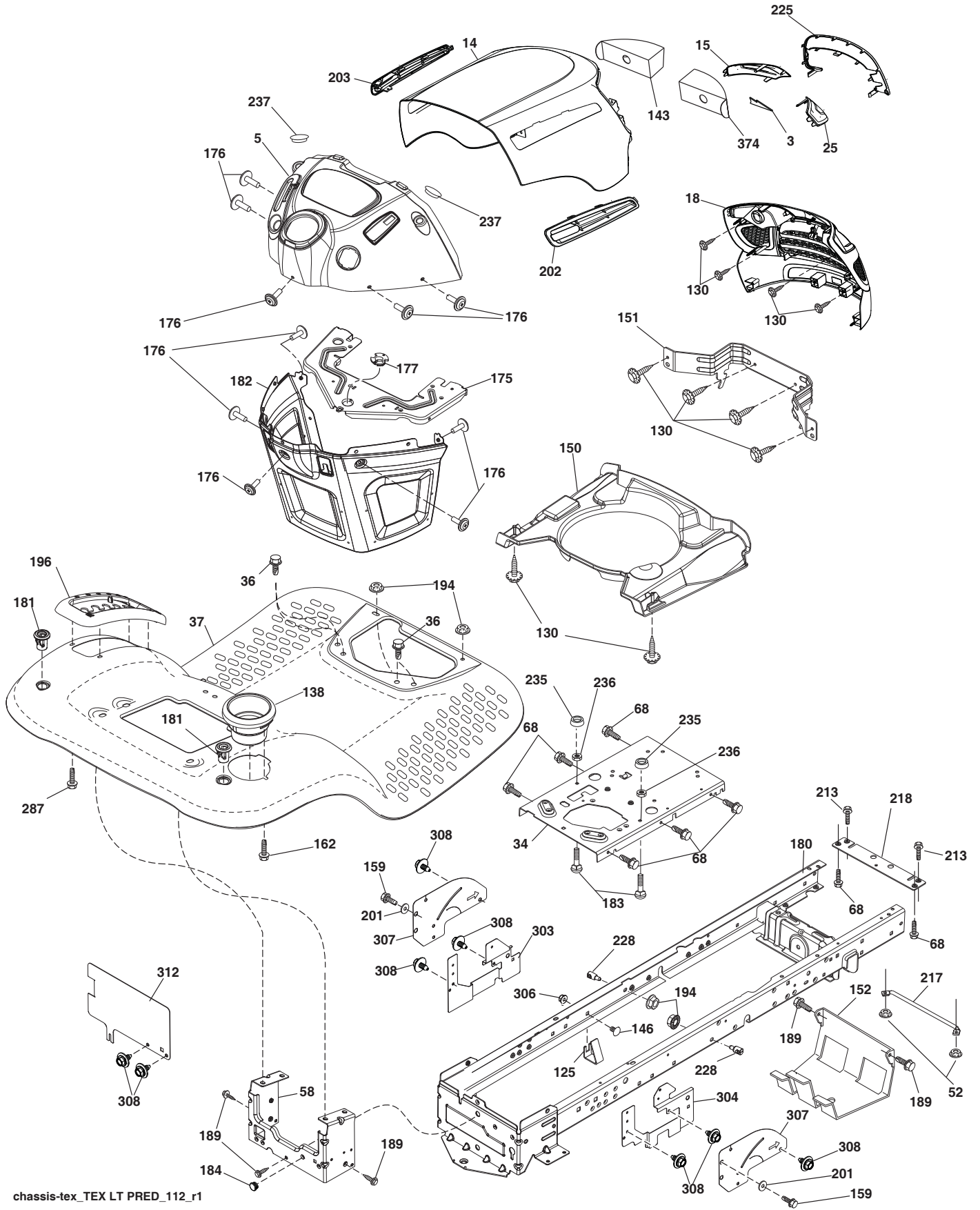

chassis-tex_TEX LT PRED_112_r1

**TRACTOR - - MODEL NO. M115-77T (96041028702), PROD. NO. 960 41 02-87
CHASSIS AND ENCLOSURES 39**

KEY NO.	PART NO.	DESCRIPTION	KEY NO.	PART NO.	DESCRIPTION
3	578 89 71-01	Emblem	184	587 55 41-01	Plug
5	532 42 57-72	Dash	189	817 00 05-12	Screw 5/16-18 x 3/4
14	581 56 47-01	Hood	194	873 90 05-00	Nut Lock Hex Flange 5/16-18
15	581 05 58-01	Lens LH	196	532 41 45-81	Console Deck Lift Asm.
18	581 05 57-01	Grille	201	819 13 20-16	Washer 13/32 x 1-1/4 x 16 Ga.
25	581 05 59-01	Lens RH	202	581 56 49-01	Vent Side Hood RH
34	580 91 08-01	Plate Engine	203	581 56 48-01	Vent Side Hood LH
36	817 06 05-12	Screw 5/16-18 x 3/4	213	874 76 05-12	Bolt 5/16-18 x 3/4
37	532 42 09-86	Fender	217	532 40 91-67	Rod Pivot Hood
52	873 68 05-00	Nut Crown Lock 5/16	218	532 19 63-95	X-Piece Hood Stop
58	532 41 22-80	Drawbar, Upper	225	581 05 62-01	Trim Ring
68	817 49 05-08	Screw THDROL 5/16-18 x 1/2	228	532 19 51-61	Stud Fastener
125	581 68 48-01	Clip Fuel Line	235	532 40 61-29	Spacer Fender
130	532 41 63-58	Screw 10 x .750 BOS Thread	236	873 93 05-00	Nut Lock 5/16-18 unc
138	532 40 97-30	Cup Holder	237	532 40 37-04	Plug Mount Cargo
143	581 05 60-01	Insert Reflective LH, MC	287	817 60 04-06	Screw Hex Washhead 1/4-20 x 3/8
146	581 85 79-01	Bolt	303	587 49 31-02	Chassis Shield French LH
150	532 40 02-67	Air Duct	304	587 49 27-02	Chassis Shield French RH
151	532 18 75-68	Bracket Pivot	306	873 90 06-00	Nut
152	532 19 95-35	Shield Browning	307	587 49 46-01	Shield Upper
159	817 00 06-12	Screw 3/8-16 x 3/4	308	532 17 18-77	Bolt 5/16-18 unc x 3/4
162	532 14 24-32	Screw HI-LO 1/4 x 1/2	312	587 49 30-02	Shield Drawbar French
175	532 19 94-72	Crossmember	374	581 05 60-02	Insert Reflective RH, MC
176	532 40 07-76	Screw 10-24 x 5/8			
177	532 19 52-28	Bushing Steering			
180	532 41 46-85	Chassis			
181	532 40 47-96	Bushing MNT Fender			
182	532 40 71-76	Dash Lower			
183	874 52 05-20	Bolt 5/16-18 x 1-1/4			

NOTE: All component dimensions given in U.S. inches
1 inch = 25.4 mm

TRACTOR - - MODEL NO. M115-77T (96041028702), PROD. NO. 960 41 02-87
DRIVE 40

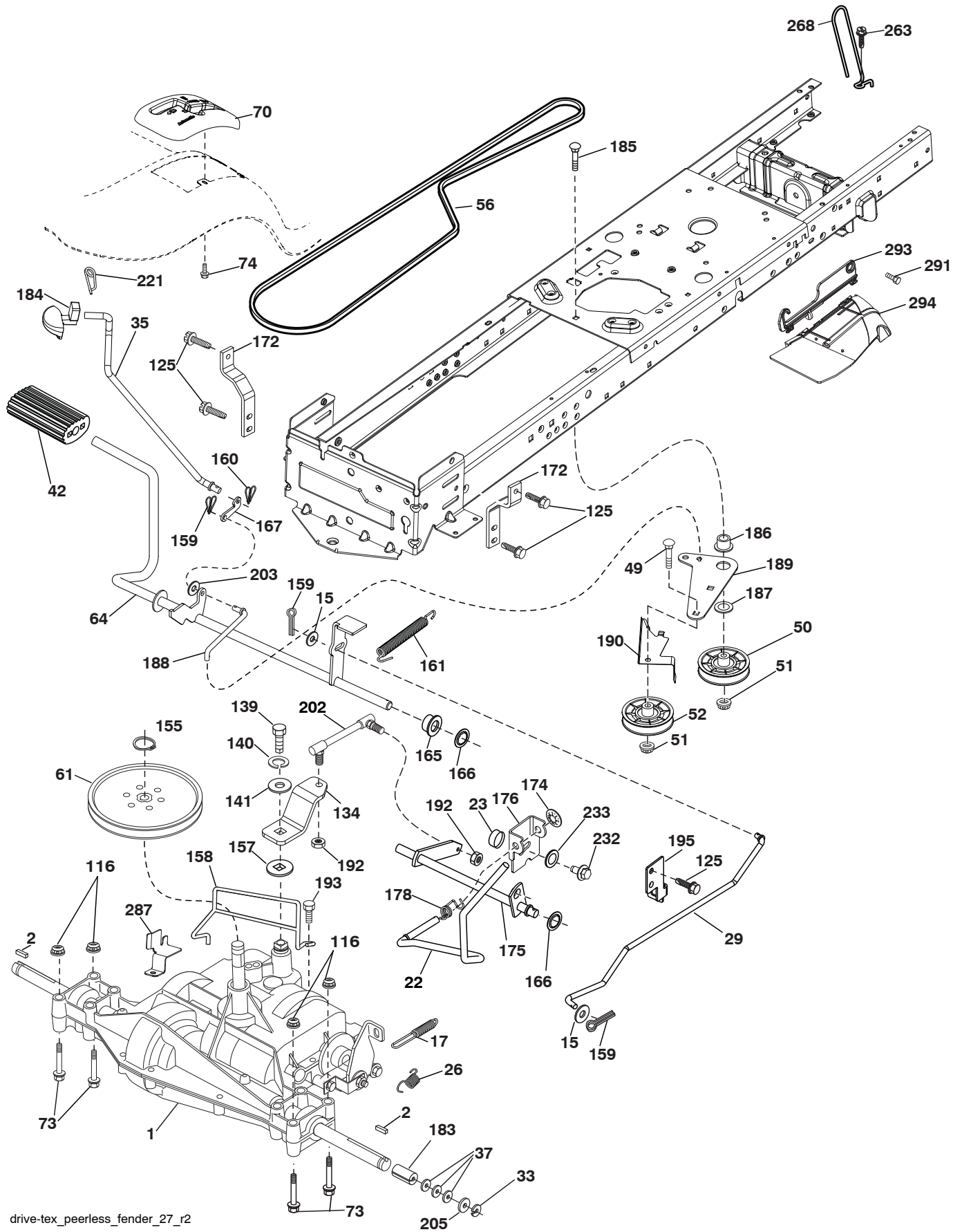

drive-tex_peerless_fender_27_r2

**TRACTOR - - MODEL NO. M115-77T (96041028702), PROD. NO. 960 41 02-87
DRIVE 40**

KEY NO.	PART NO.	DESCRIPTION	KEY NO.	PART NO.	DESCRIPTION
1	-----	Transaxle, Peerless 206-565 (197941) (Order parts from trans-axle manufacturer.)	165	532 19 62-12	Busing Shaft Brake Hand Control
2	532 12 35-83	Key Square	166	532 42 91-64	Nut Push .625
15	819 13 13-16	Washer 13/32 x 13/16 x 16 Ga.	167	532 40 52-57	Latch Brake Parking
17	532 19 72-97	Spring, Brake	172	532 19 76-57	Strap Torque LH
22	532 19 76-60	Rod Shift	174	532 19 72-89	Nut Push
23	532 10 69-33	Knob	175	532 19 78-58	Shaft Asm. Shift
26	532 19 74-55	Spring Brake Return	176	532 19 62-14	Arm Clevis Rod Shift
29	532 19 72-67	Rod, Brake	178	532 19 74-56	Spring Shift
33	812 00 00-01	Ring E	183	532 13 70-57	Spacer Axle
35	532 40 10-31	Rod, Brake, Park	184	532 41 14-84	Handle Parking Brake
37	532 12 17-49	Washer 25/32 x 1-1/4 x 16 Ga.	185	872 11 06-22	Bolt 3/8-16 unc x 2-3/4 Gr. 5
42	532 12 48-72	Cover, Foot Pedal	186	532 19 43-21	Spacer Retainer
49	872 11 06-14	Bolt	187	819 13 32-10	Washer
50	532 19 43-27	Pulley Idler Flat	188	582 21 70-01	Link Clutch Ground Drive, Long
51	873 90 06-00	Lock Nut 3/8-16	189	532 19 43-17	Bellcrank Ground Drive
52	532 19 43-26	Idler V-Groove	190	532 19 43-18	Keeper Bellcrank Ground Drive
56	532 13 82-55	V-Belt, Drive	192	532 15 03-60	Nut Lock Center 1/4-28 Fnthd
61	532 16 59-99	Pulley Transaxle	193	817 06 05-12	Screw 5/16-18 x 3/4
64	532 19 62-00	Shaft Asm. Pedal Brake Control	195	532 19 73-32	Bracket Brake Rod
70	532 41 12-90	Console Shift	202	532 19 78-59	Link Transaxle
73	874 49 05-40	Bolt Hex Flghd 5/16-18 Gr. 5	203	819 11 11-16	Washer 11/32 x 11/16 x 16 Ga.
74	532 14 24-32	Screw Hex Wsh 1/4 x 1/2	205	532 12 17-48	Washer 25/32 x 1-5/8 16 Ga.
116	873 90 05-00	Nut Lock Hex Flange 5/16-18	221	532 40 31-87	Retainer Spring Clip Handle
125	817 00 05-12	Screw 5/16-18 x 3/4	232	874 78 07-16	Bolt Hex 7/16-14 x 1 Gr. 5
134	532 19 78-57	Asm Shift	233	532 40 52-96	Washer Serrated
139	874 55 04-12	Bolt 1/4-28 unf Gr. 8 w/Patch	263	817 00 06-12	Screw Hexwsh THDR 3/8-16 x 3/4
140	810 04 04-00	Washer Lock Hvy Helical 1/4	268	532 18 24-02	Guard Muffler
141	819 09 12-10	Washer 9/32 x 3/4 x 10 Ga.	287	532 42 16-48	Keeper Pulley Transaxle
155	812 00 00-28	Ring Retainer	291	532 17 01-65	Bolt Shoulder 5/16-18 TT
157	532 10 57-01	Washer Plate Shift	293	532 42 25-48	Hinge RH
158	532 19 43-52	Belt Keeper	294	532 43 03-03	Guard Asm. RH
159	876 02 04-12	Pin Cotter 1/8 x 3/4			
160	532 16 94-84	Retainer Clip			
161	532 10 57-09	Spring, Return, Clutch			

NOTE: All component dimensions given in U.S. inches
1 inch = 25.4 mm

TRACTOR - - MODEL NO. M115-77T (96041028702), PROD. NO. 960 41 02-87
 ENGINE 24

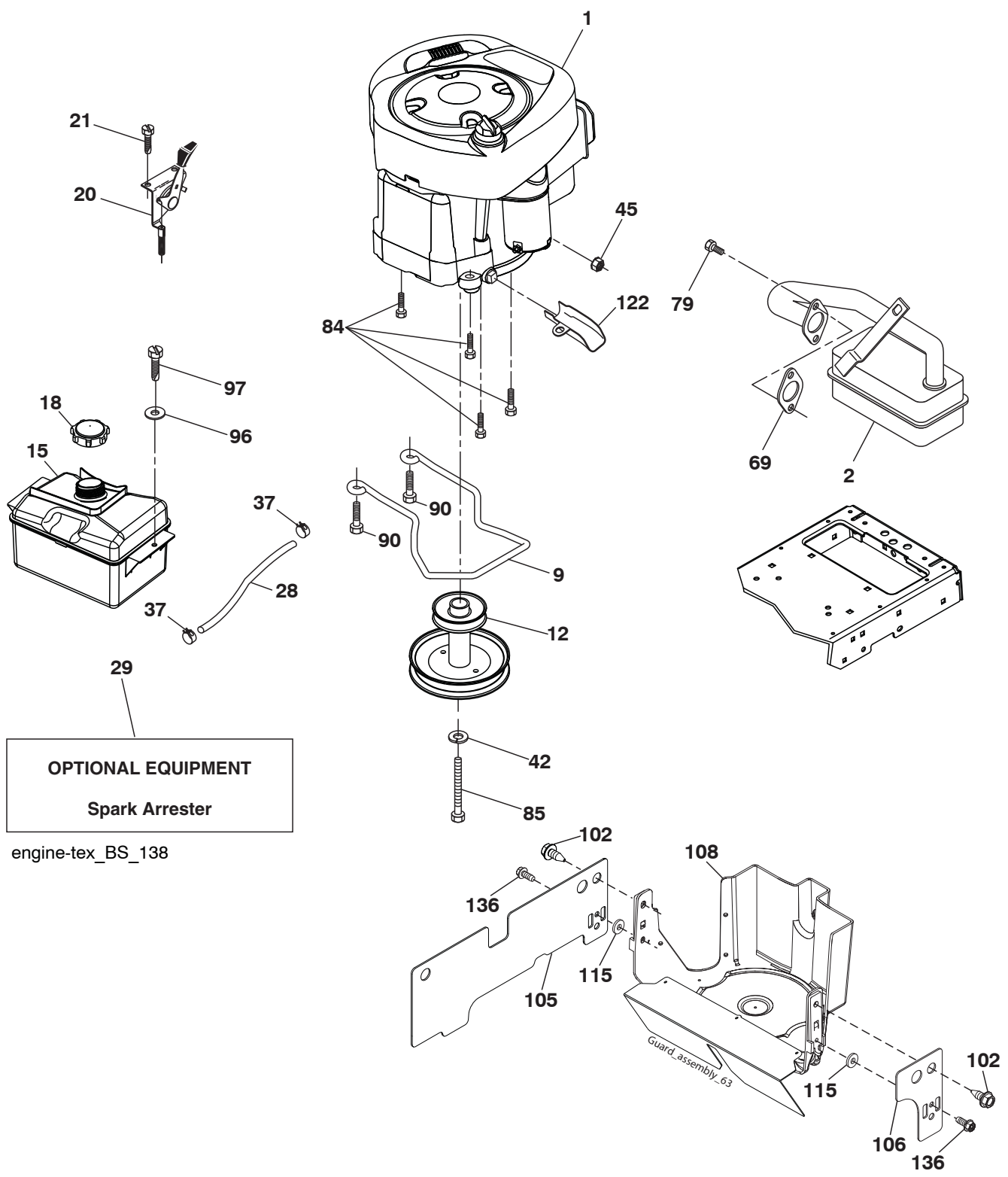

**TRACTOR - - MODEL NO. M115-77T (96041028702), PROD. NO. 960 41 02-87
ENGINE 24**

KEY NO.	PART NO.	DESCRIPTION
1	-----	Engine Briggs Model No. 21R607-0003-H1 (585579701) (Order parts from engine manufacturer.)
2	532 17 97-58	Muffler
9	582 54 03-02	Keeper Belt Engine
12	532 14 01-86	Pulley Engine
15	581 28 99-01	Tank Fuel
18	532 43 02-20	Cap Asm
20	532 18 38-97	Control Throttle
21	532 41 63-58	Screw #10 x 0.750 BOS Thread
28	532 13 70-40	Fuel Line
29	532 13 71-80	Spark Arrester Kit
37	532 12 34-87	Clamp Hose
42	810 04 07-00	Washer Lock 7/16
45	873 51 04-00	Nut Keps Hex 1/4-20 unc
69	532 16 52-91	Gasket
79	532 19 23-34	Screw 5/16-18 x 3/4
84	817 06 06-20	Screw 3/8-16 x 1/4
85	532 17 39-37	Bolt Hex 7/16-20 x 4 Gr. 5
90	817 00 06-16	Screw 3/8-16 x 1
96	819 09 14-16	Washer 9/32 x 7/8 x 16 Ga.
97	817 67 04-12	Screw 1/4-20 x 3/4
105	532 42 08-94	Shield SRD LH
106	532 43 02-57	Shield SRD RH
102	817 00 05-12	Screw 5/16-18 x 3/4
108	587 17 95-04	Cover Pulley Eng. w/SHLD 30"
115	532 42 30-62	Palnut 1/4
122	532 42 19-22	Extension Drain Oil
136	532 13 77-29	Screw THD Roll 1/4-20 x 5/8

NOTE: All component dimensions given in U.S. inches
1 inch = 25.4 mm

Engine Power Rating Information

The gross power rating for individual gas engine models is labeled in accordance with SAE (Society of Automotive Engineers) code J1940 (Small Engine Power & Torque Rating Procedure), and rating performance has been obtained and corrected in accordance with SAE J1995 (Revision 2002-05). Torque values are derived at 3060 RPM; horsepower values are derived at 3600 RPM. Actual gross engine power will be lower and is affected by, among other things, ambient operating conditions and engine-to-engine variability. Given both the wide array of prod.s on which engines are placed and the variety of environmental issues applicable to operating the equipment, the gas engine will not develop the rated gross power when used in a given piece of power equipment (actual "on-site" or net power). This difference is due to a variety of factors including, but not limited to, accessories (air cleaner, exhaust, charging, cooling, carburetor, fuel pump, etc.), application limitations, ambient operating conditions (temperature, humidity, altitude), and engine-to-engine variability. Due to manufacturing and capacity limitations, Briggs & Stratton may substitute an engine of higher rated power for this Series engine.

TRACTOR - - MODEL NO. M115-77T (96041028702), PROD. NO. 960 41 02-87
STEERING ASSEMBLY **41**

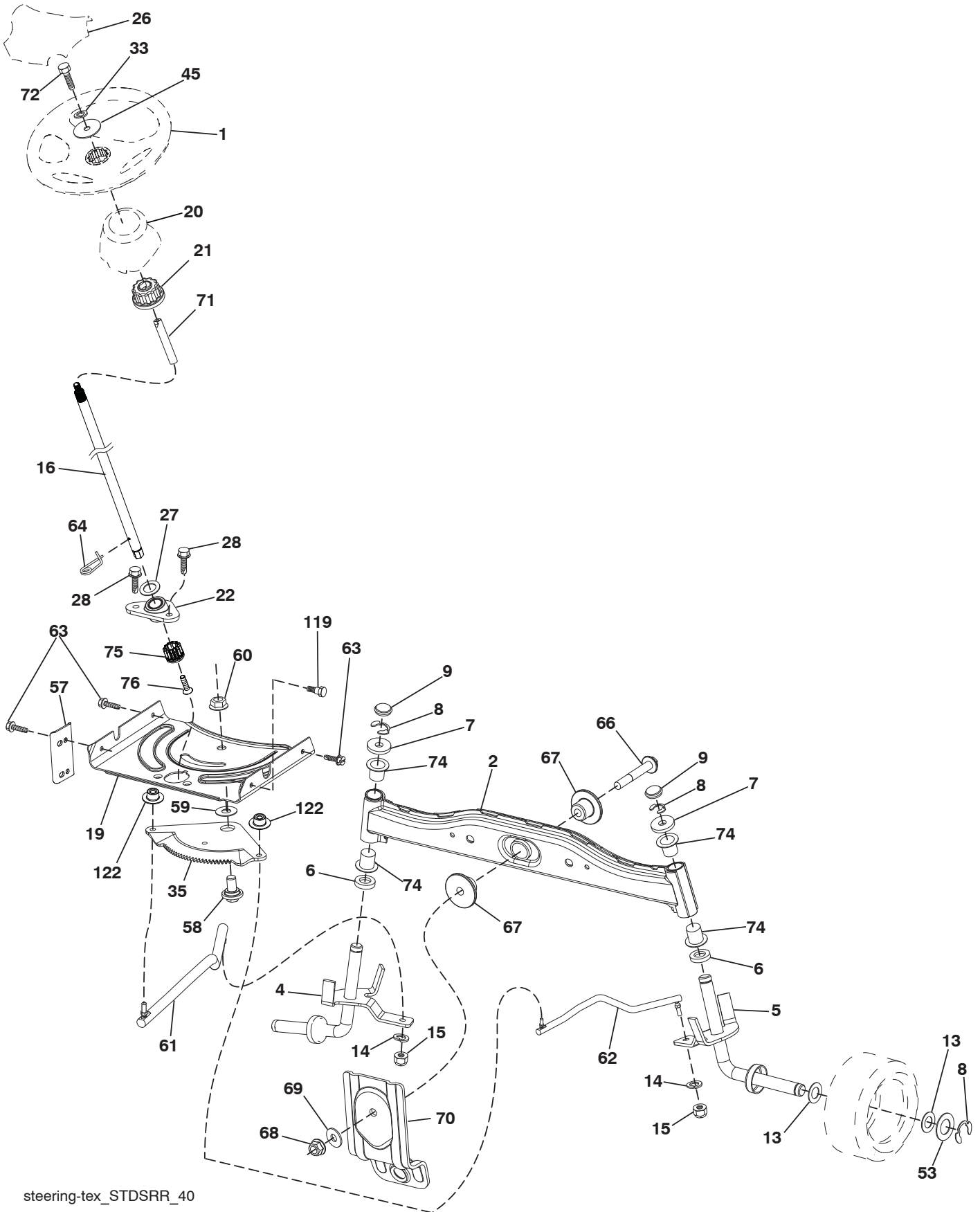

steering-tex_STDSRR_40

**TRACTOR - - MODEL NO. M115-77T (96041028702), PROD. NO. 960 41 02-87
STEERING ASSEMBLY **41****

KEY NO.	PART NO.	DESCRIPTION
1	532 42 45-51	Wheel, Steering
2	532 41 81-68	Axle Asm., Front
4	532 41 68-45	Spindle Asm., LH
5	532 41 68-46	Spindle Asm., RH
6	532 12 49-31	Washer Thrust
7	532 12 17-48	Washer 25/32 x 1-5/8 x 16 Ga.
8	812 00 00-29	Ring, Klip #T5304-75
9	532 12 12-32	Cap, Spindle
13	532 12 17-49	Washer 25/32 x 1-1/4 x 16 Ga.
14	810 04 06-00	Washer, Lock Hvy Hlcl Spr 3/8
15	873 54 06-00	Nut, Crown Lock 3/8-24 unf
16	585 86 92-02	Steering Shaft
19	532 19 47-29	Plate Steering
20	532 40 97-63	Boot, Steering
21	532 18 67-37	Adapter, Wheel Steering
22	585 02 98-02	Bearing
26	532 42 45-53	Insert, Wheel Steering
27	819 21 16-16	Washer 21 x 32 x 1 x 16 Ga.
28	817 00 06-12	Screw 3/8-16 x 3/4
33	810 04 05-00	Washer Lock 5/16
35	532 19 47-32	Gear, Sector Plate
45	819 11 38-12	Washer 11/32 x 3/8 x 12 Ga.
53	532 18 89-67	Washer Hardened .793 x 1.637 x .060
57	532 40 74-65	Bracket Upstop
58	532 19 47-47	Bolt Shoulder Sector Pivot CFM
59	532 19 47-48	Washer Thrust Sector Steering
60	873 97 10-00	Nut Flange Lock 5/8-11
61	532 19 47-40	Draglink, LH
62	532 19 47-41	Draglink, RH
63	817 00 05-12	Screw 5/16-18 x 3/4
64	532 19 98-49	Retainer Clip Spring Steering
66	871 02 07-48	Bolt Hex Fghd 7/16-14 x 3 Serr
67	532 19 47-37	Bushing PM Front Axle
68	873 90 07-00	Nut Lock Flange 7/16-14 Gr. 5
69	532 19 91-62	Washer 1.5 x .505 x .118
70	532 41 70-65	Bracket Deck Susp. Front
71	532 19 07-52	Shaft Extension Steering
72	532 42 89-82	Bolt Fin Hex 5/16-18 x 4 w/Patch
74	532 12 49-37	Bearing
75	580 68 37-01	Pinion
76	580 68 36-01	Screw Head Sock
119	532 17 01-65	Bolt Shoulder
122	532 44 49-62	Cap Gear

NOTE: All component dimensions given in U.S. inches
1 inch = 25.4 mm

**TRACTOR - - MODEL NO. M115-77T (96041028702), PROD. NO. 960 41 02-87
MOWER DECK 44**

KEY NO.	PART NO.	DESCRIPTION	KEY NO.	PART NO.	DESCRIPTION
1	532 41 92-72	Deck Weldment 30"SRD	34	587 25 65-01	Shaft Asm Mndrl N/Greaseable38
2	532 19 51-61	Stud Fastner w/'D'anti-Rotatio	35	532 41 92-73	Blade Mower Hp/Mulch Srd
3	873 90 05-00	Nut Lock Hex Flange 5/16 - 18	37	819 13 13-16	Washer 13/32 x 13/16 x 16 Ga.
4	532 41 76-45	Bracket Clutch Cable	38	532 19 65-39	Bolt Shoulder
5	817 00 05-10	Bolt 5/16-18	39	532 10 53-04	Cap Sleeve
6	532 41 88-63	Arm Susp Mower Rear Srd	40	532 41 92-70	Keeper Belt Engine LH
7	532 41 63-58	Screw #10 x 0.750 BOS Thread	41	532 41 92-65	Keeper Belt Engine RH
8	532 42 02-52	Arm Idler 30"Srd	42	817 00 06-12	ScrewHexwsh THDR3/8-16x3/4BL
9	532 19 90-92	Spacer Retainer	43	532 41 68-77	Pulley Mandrel 6 5 Pd 30"
10	817 00 06-16	Screw 3/8 - 16 X 1 Smgml Tap/R Blk	67	532 40 30-12	Handle ClutchCable
11	532 13 77-29	Screw Thd Roll 1/4 - 20 X 5/8	68	584 95 39-01	Bolt Hex Wsh Hd .313-18 x 1.19
12	532 19 94-70	Arm Brake Mower 38" RH Tex	69	584 30 93-01	Screw Sems 7/16-20 x 1 Hex Hd.
13	872 11 06-12	Bolt Carr Sh 3/8 - 16 X 1 - 1/2 Gr5	70	532 40 12-46	Clutch Asm. Manual
14	532 15 60-85	Keeper Belt Idler	76	532 41 55-98	Washout Port
15	532 14 67-63	Pulley Ikler V-Groove Dim 4.25	78	532 42 25-66	Guard Deck SRD Arm Clutch
16	873 90 06-00	Nut Lock FIG 3/8 - 16 unc	79	532 14 24-32	Screw Hex Wsh. Hi Lo 1/4 x 1/2 unc
17	532 40 02-34	Nut Flange Lock Top	80	532 42 30-62	Palnut 1/4
19	585 32 39-01	Bearing Ball Mandrel	81	532 42 53-67	Shield Asm. Suspension
21	532 41 69-10	Keeper Belt Mandrel 30"	83	532 43 03-15	Shield Side LH
22	532 19 31-98	Pulley Idler Flat Unplated	152	532 43 51-11	Manual Clutch Cable
23	817 49 06-28	Screw Thdrol 3/8 - 16 X 1-3/4	--	587 25 33-01	MandrelAssembly (Includeshousing (key #33), shaft assembly (key #34), and bearing (key #19) only - pulley/ nut/washer and blade bolt/washers not included)
24	819 13 20-12	Washer 13/32 X 1 - 1/4 X 12 Ga	--	532 43 19-58	Replacement Mower Complete
25	532 42 02-53	Keeper Belt 30"Srd			
26	532 42 02-55	Cover Mandrel Mwr 30"Black			
27	532 41 92-71	V-Belt Drive			
28	532 41 73-44	Shield Asm Deflect Mwr			
29	532 42 08-95	Pin Hinge 30			
30	532 19 70-26	Spring Torsion Dfl 38/42/46 Gr			
31	532 11 04-52	Nut Push Phos & Oil			
32	532 40 18-72	Spring Return Deck 38/46"			
33	532 18 72-81	Housing Mandrel 4pt Service			

NOTE: All component dimensions given in U.S. inches
1 inch = 25.4 mm

TRACTOR - - MODEL NO. M115-77T (96041028702), PROD. NO. 960 41 02-87
MOWER LIFT 45

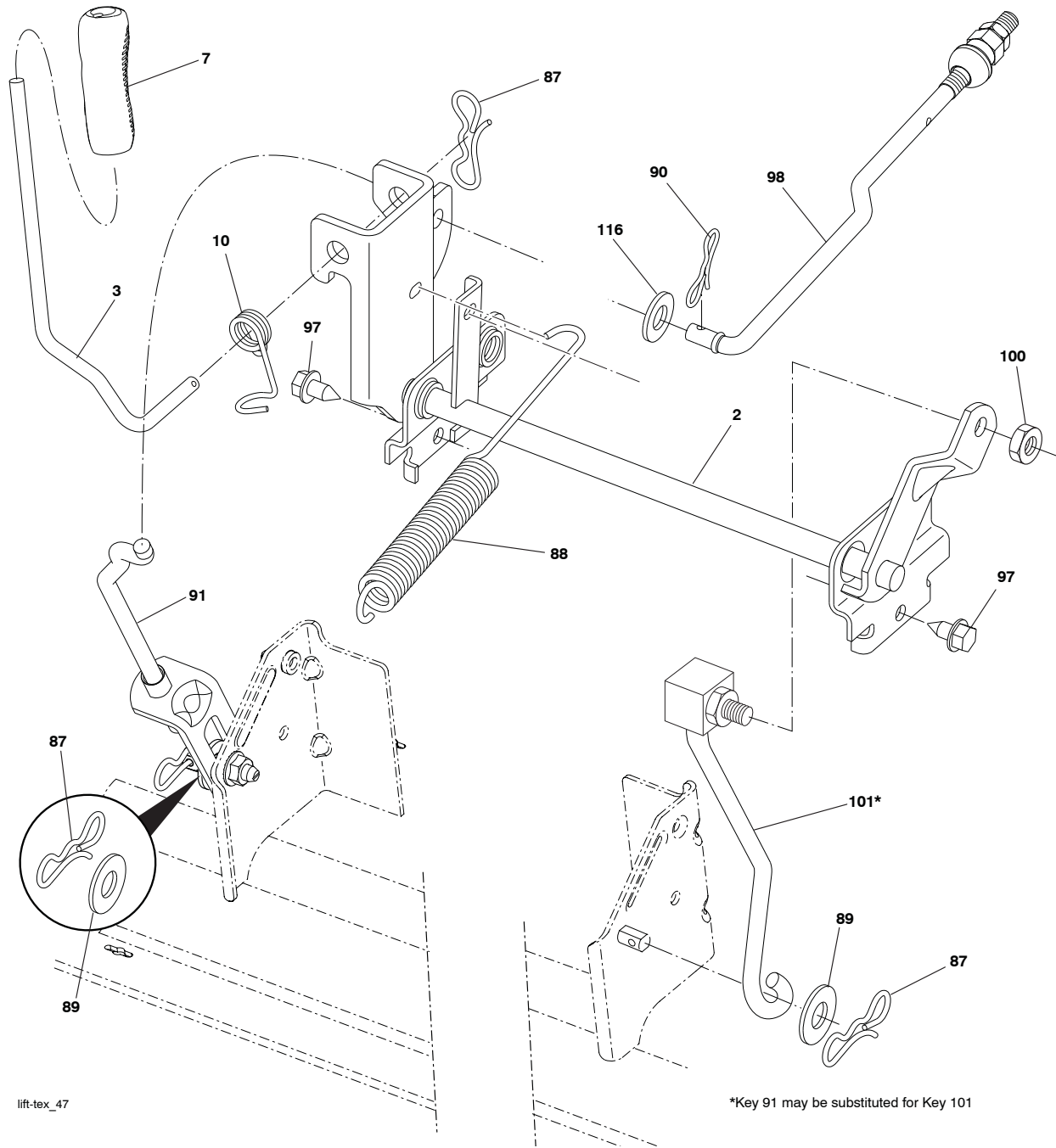

lift-tex_47

*Key 91 may be substituted for Key 101

KEY NO.	PART NO.	DESCRIPTION
2	532 42 20-27	Shaft Asm., Lift
3	532 19 52-31	Lever Asm., Lift RH
7	580 96 23-01	Grip, Lever
10	532 19 63-14	Spring Torsion
87	532 19 42-09	Pin Cotter 7/16 Bow Tie Lock
88	532 41 07-10	Spring Lift Assist
89	819 19 19-12	Washer Clear
90	532 19 42-08	Pin Cotter 5/16 Bow Tie Lock
91	532 19 51-81	Link Asm Lift LH Rear

KEY NO.	PART NO.	DESCRIPTION
97	817 00 06-12	Screw Hex Wsh. THDR 3/8-16 x 3/4
98	532 19 52-64	Link Lift Susp. Front Mower
100	873 93 06-00	Nut Centerlock 3/8-16 unc
101	532 40 70-03	Link Asm Lift FXD
116	819 15 15-16	Washer 15/32 x 15/16 x 16 Ga.

NOTE: All component dimensions given in U.S. inches
 1 inch = 25.4 mm

**TRACTOR - - MODEL NO. M115-77T (96041028702), PROD. NO. 960 41 02-87
SEAT ASSEMBLY 42**

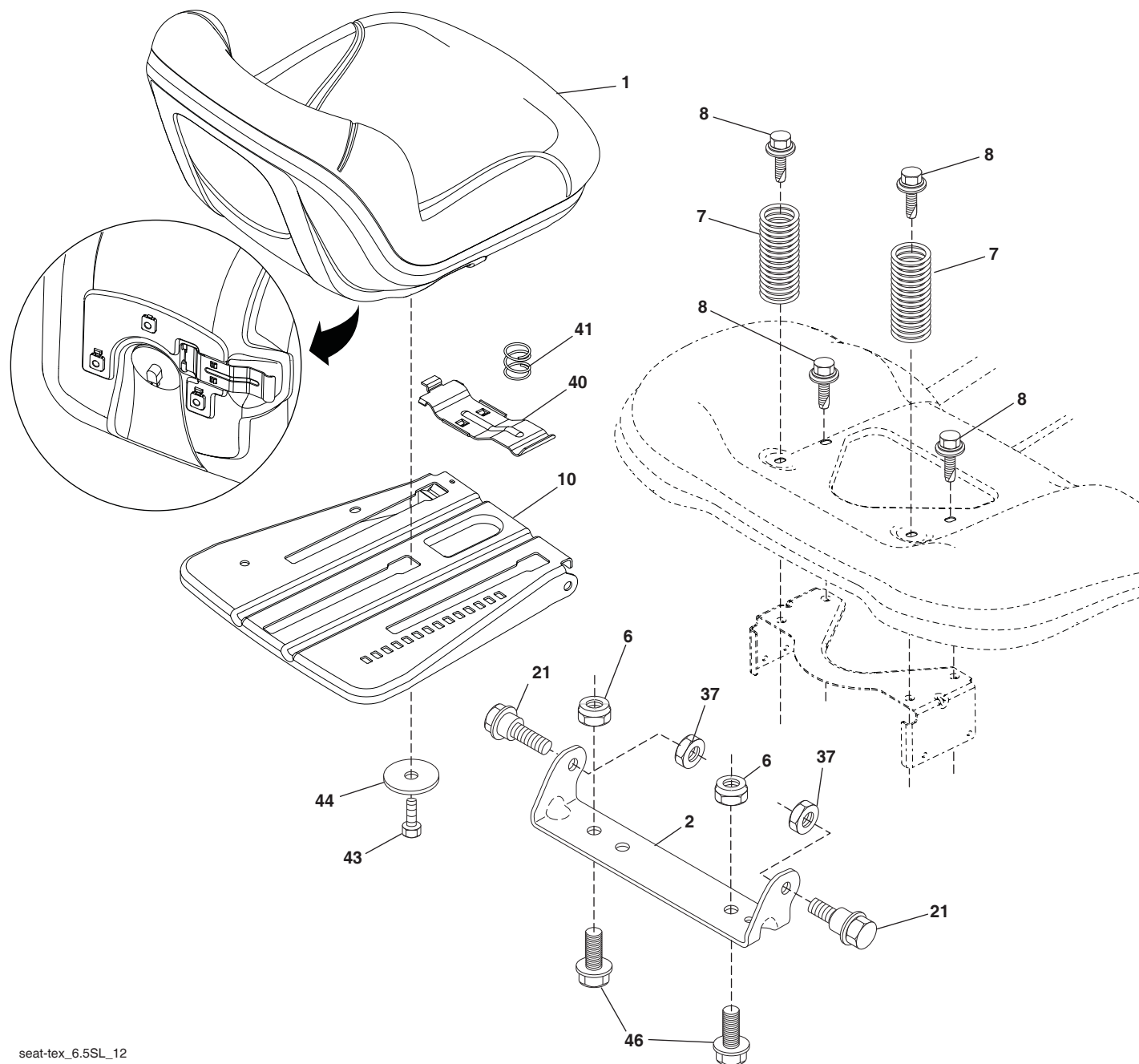

seat-tex_6.5SL_12

KEY NO.	PART NO.	DESCRIPTION
1	581 46 20-01	Seat
2	532 18 01-66	Bracket Pivot Fender
6	873 80 06-00	Nut, Lock w/Ins. 3/8-16 unc
7	587 61 33-01	Spring, Seat Cprsn
8	532 17 18-77	Bolt 5/16-18 unc x 3/4 w/Sems
10	532 19 69-77	Pan, Seat
21	587 90 78-01	Bolt, Shoulder 5/16-18 x 5/8
37	873 80 05-00	Nut, Lock 5/16-18 unc
40	532 19 76-61	Handle Slide Seat

KEY NO.	PART NO.	DESCRIPTION
41	532 19 82-00	Spring Latch Seat
43	874 76 06-12	Bolt Fin Hex 3/8-16 unc x 3/4
44	819 13 38-12	Washer 13/32 x 2-3/8 x 12 Ga.
46	588 09 04-01	Bolt 3/8-16 x 1; 1.25 OD Wshr

NOTE: All component dimensions given in U.S. inches
1 inch = 25.4 mm

