

ILLUSTRATED PARTS LIST

MFG. ID NO. 96051013200

CUSTOMER CATALOG NO. M115-97TC

PRODUCT NO. 960 51 01-32

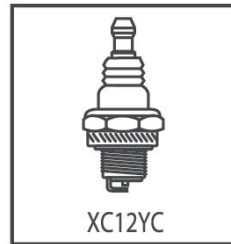
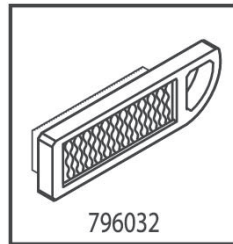

47

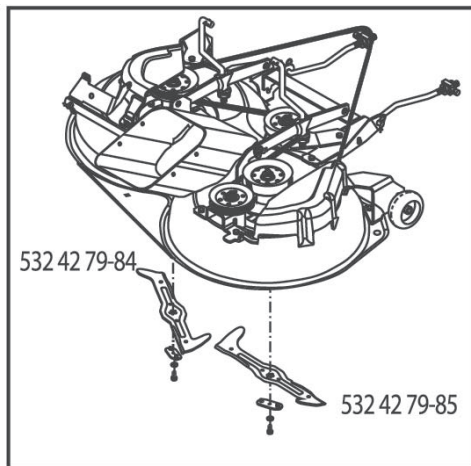
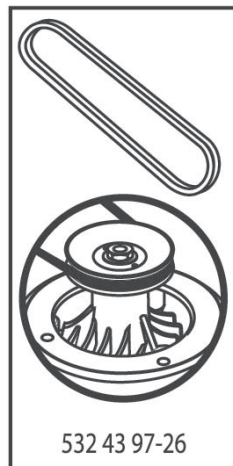

587027401

TRACTOR - MODEL NO. M115-97TC (96051013200), PROD. NO. 960 51 01-32
DECALS 27

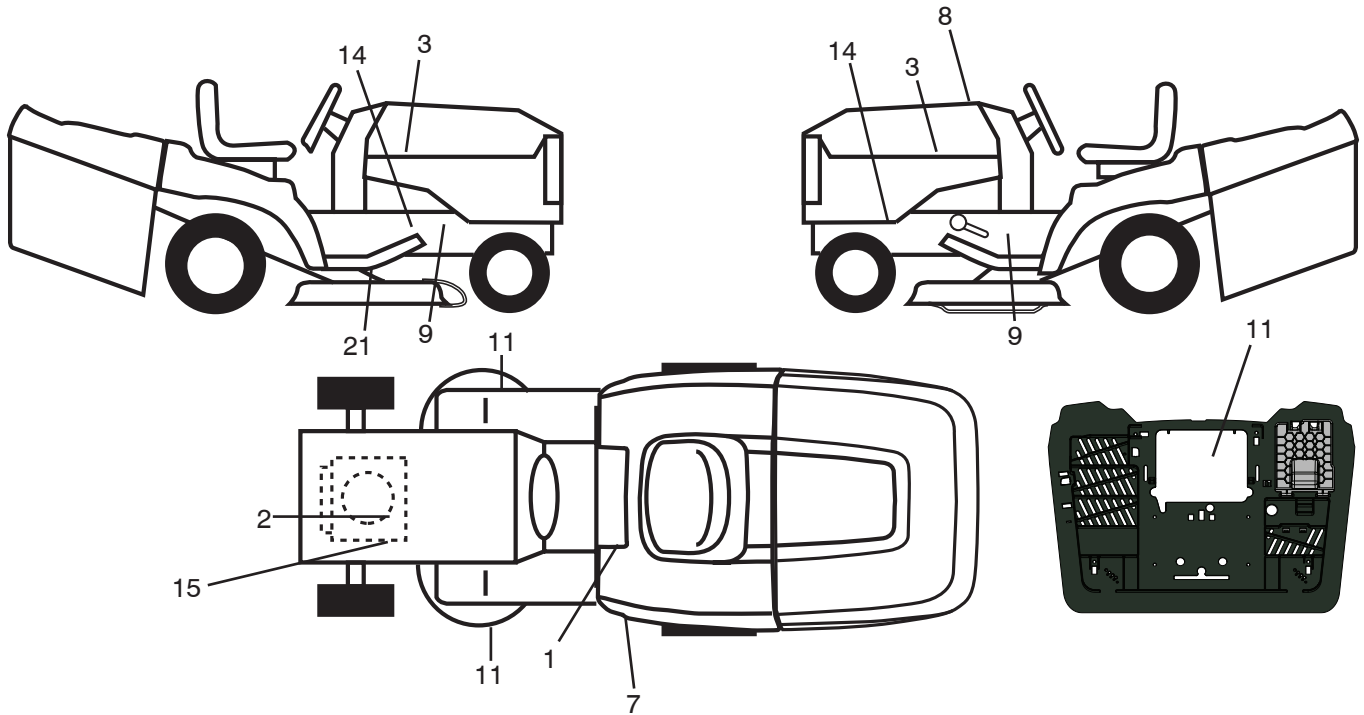

KEY NO.	PART NO.	DESCRIPTION
1	581 57 83-01	Decal, Warning
2	581 57 97-01	Decal, Warning Eng. Sym.
3	581 09 12-01	Decal, Hood RH/LH
7	587 26 93-01	Decal, Fender
8	587 02 74-01	Decal, Replacement
9	581 57 98-01	Decal, Warning
11	581 57 91-01	Decal, Mower Cut Finger Symbol
14	581 57 96-01	Decal, Chassis Hot Muffler
15	585 55 44-01	Decal, Engine HP

KEY NO.	PART NO.	DESCRIPTION
21	532 44 11-89	Decal, Belt Sch CRD
--	532 44 27-44	Decal, Battery
--	532 42 59-86	Pad Footrest RH
--	532 42 59-76	Pad Footrest LH
--	588 89 31-20	Manual Operator's (Euro)
--	588 89 31-10	Manual Operator's (Scan)
--	588 89 31-50	Manual Operator's (E-Bloc)
--	588 89 31-40	Manual Operator's (Baltic)

WHEELS & TIRES

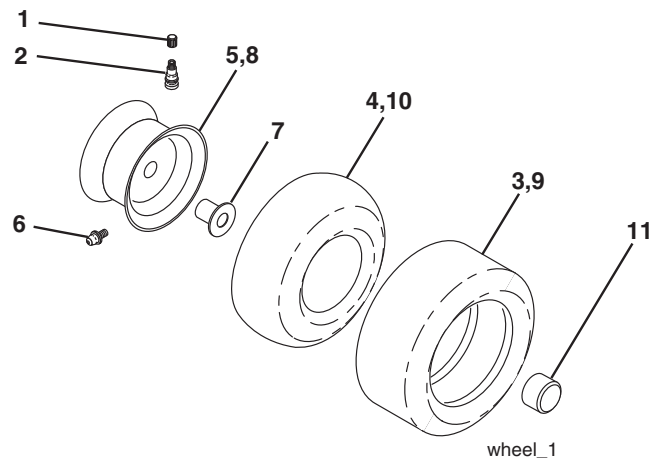

KEY NO.	PART NO.	DESCRIPTION
1	532 05 91-92	Cap Valve Tire
2	532 06 51-39	Stem Valve
3	532 10 62-22	Tire Front 15 x 6-6
4	532 05 99-04	Tube Inner Front #35060
5	532 12 51-21	Rim Asm 6" Front Silver Service
6	532 12 49-57	Fitting Grease
7	532 12 49-59	Bearing Flange
8	532 12 51-22	Rim Asm 8" Rear Silver Service
9	532 12 46-35	Tire Rear 18 x 8.5-8
10	532 12 49-26	Tube Rear 8.5 x 8
11	532 19 32-68	Cap Axle
--	532 14 43-34	Sealant, Tire (10 oz. Tube)

NOTE: All component dimensions given in U.S. inches
 1 inch = 25.4 mm

TRACTOR - MODEL NO. M115-97TC (96051013200), PROD. NO. 960 51 01-32

SCHEMATIC 38

SCH17

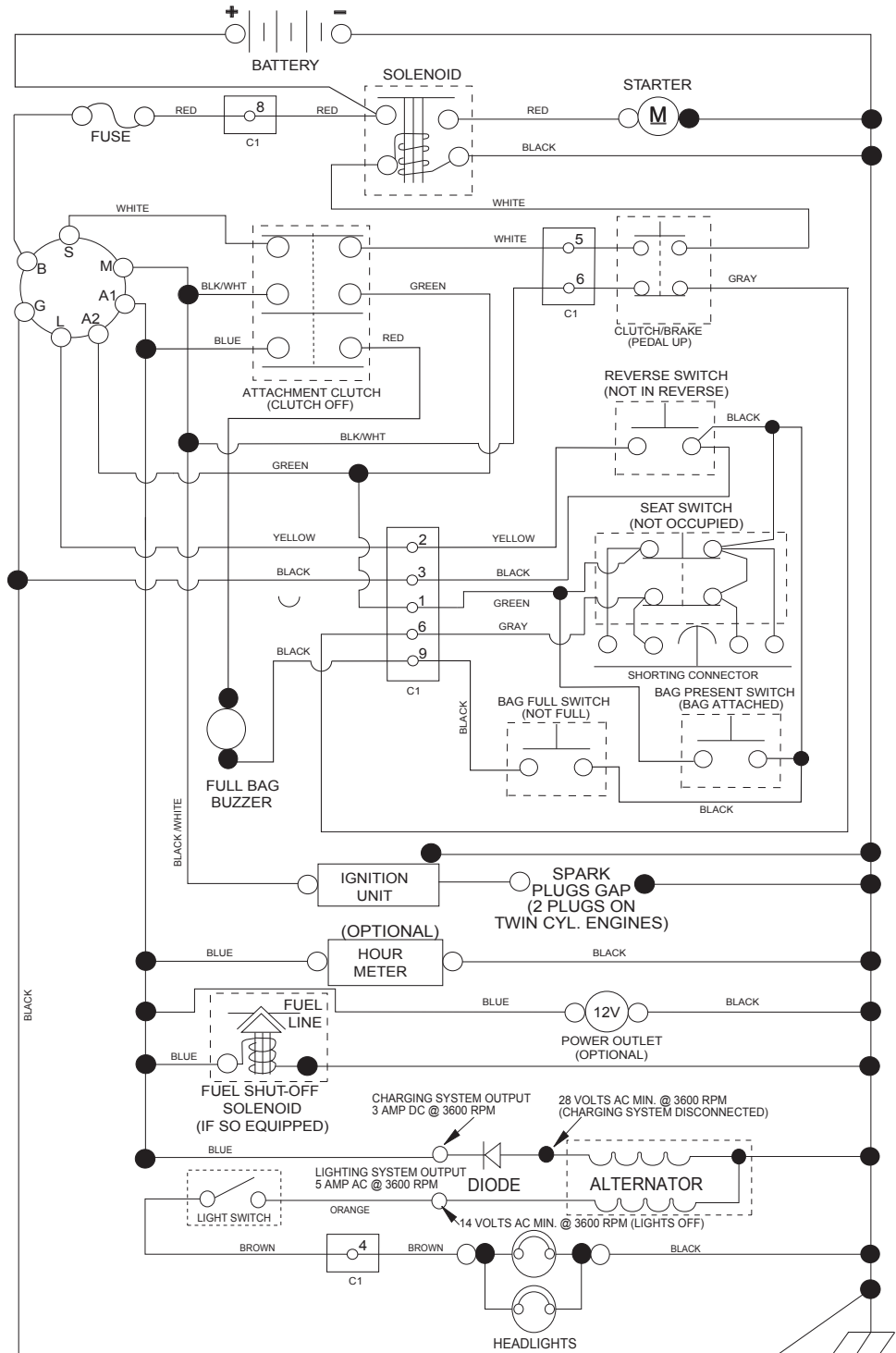

NOTE
 YOUR TRACTOR IS EQUIPPED WITH A SPECIAL ALTERNATOR SYSTEM. THE LIGHTS ARE NOT CONNECTED TO THE BATTERY, BUT HAVE THEIR OWN ELECTRICAL SOURCE. BECAUSE OF THIS, THE BRIGHTNESS OF THE LIGHTS WILL CHANGE WITH ENGINE SPEED. AT IDLE THE LIGHTS WILL DIM. AS THE ENGINE SPEED IS INCREASED, THE LIGHTS WILL BECOME THEIR BRIGHTEST.



IGNITION SWITCH

POSITION	CIRCUIT	"MAKE"
OFF	M+G+A1	
RUN/OVERRIDE	B+A1	
RUN	B+A1	L+A2
START	B + S + A1	



CHASSIS HARNESS CONNECTOR (C1) (MATING SIDE)



DASH HARNESS CONNECTOR (C1) (MATING SIDE)

WIRING INSULATED CLIPS
 NOTE: IF WIRING INSULATED CLIPS WERE REMOVED FOR SERVICING OF UNIT, THEY SHOULD BE RE-INSTALLED TO PROPERLY SECURE YOUR WIRING.

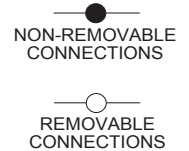

TRACTOR - MODEL NO. M115-97TC (96051013200), PROD. NO. 960 51 01-32
ELECTRICAL 32

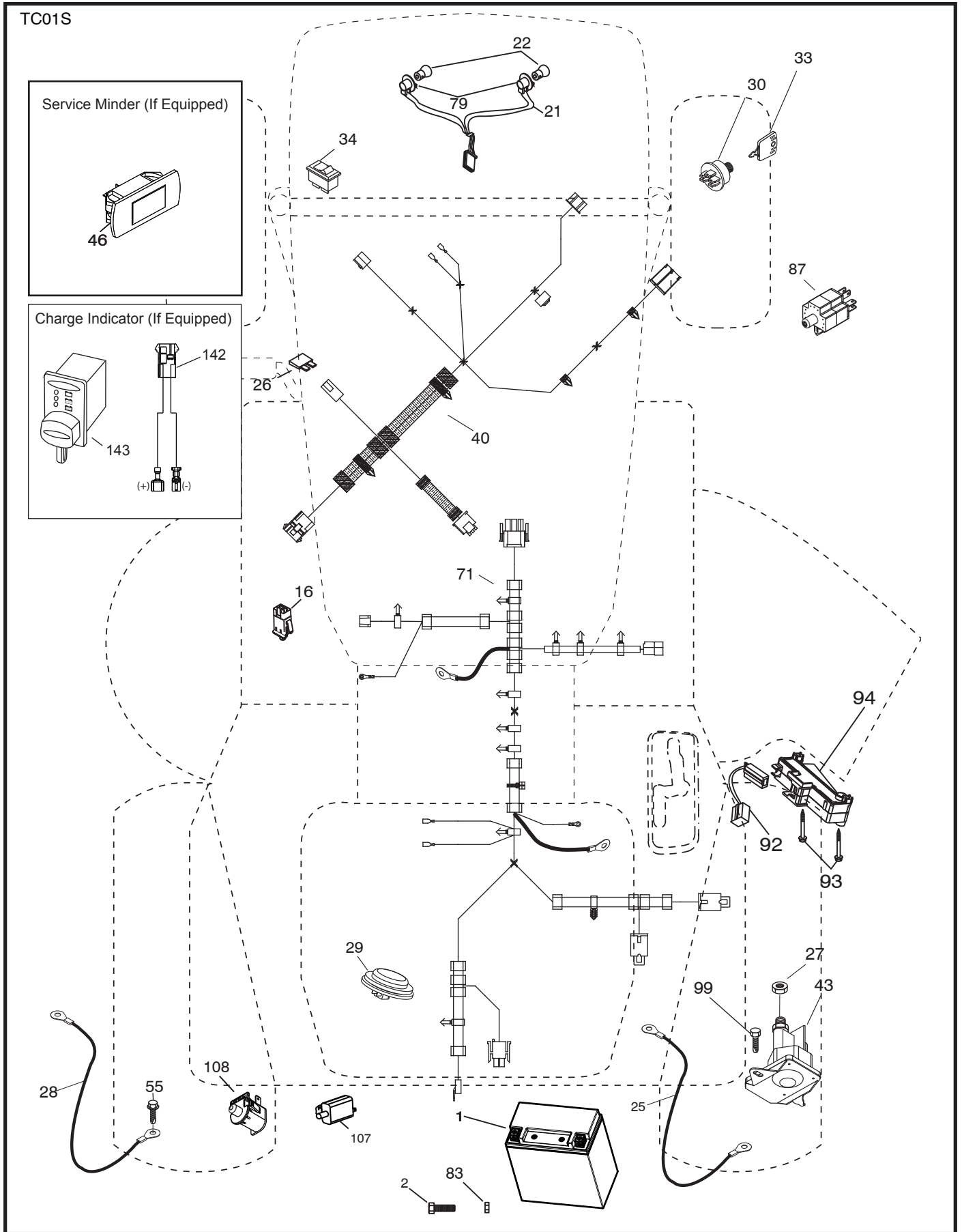

**TRACTOR - MODEL NO. M115-97TC (96051013200), PROD. NO. 960 51 01-32
ELECTRICAL 32**

KEY NO.	PART NO.	DESCRIPTION
1	532 43 71-57	Battery
2	532 44 09-23	Screw Hex Hd Cap M6 x 1.12mm
16	532 17 61-38	Switch Interlock
21	532 40 02-52	Harness Asm Light w/4152J
22	532 00 41-52	Bulb Light #1156
25	581 48 98-01	Cable Battery Red
26	532 17 51-58	Fuse
27	873 51 04-00	Nut Keps Hex 1/4-20 unc
28	581 48 98-02	Cable Ground Black
29	532 40 15-45	Switch Seat
30	532 19 33-50	Switch Ignition
33	532 41 19-35	Key/Chain
34	532 11 07-12	Switch Light
40	532 42 10-02	Harness Ignition Dash
43	532 19 25-07	Solenoid
55	817 06 05-12	Screw 5/16-18 x 3/4
71	585 84 97-01	Harness Chassis
79	532 17 52-42	Socket Asm.
83	532 43 67-74	Nut Square M6 x 1 x 8.5 x 11mm
87	532 42 10-60	Switch Railmount
92	532 19 66-15	Harness Pigtail
93	532 19 25-40	Screw Plastite 10-14 x 2.00
94	532 19 18-34	Module Reverse ROS
99	817 00 05-12	Screw 5/16-18 x 3/4
107	532 18 03-79	Switch Full Bagger Indicator
108	532 42 10-62	Switch Snapmount

NOTE: All component dimensions given in U.S. inches
1 inch = 25.4 mm

TRACTOR - MODEL NO. M115-97TC (96051013200), PROD. NO. 960 51 01-32
CHASSIS AND ENCLOSURES 39

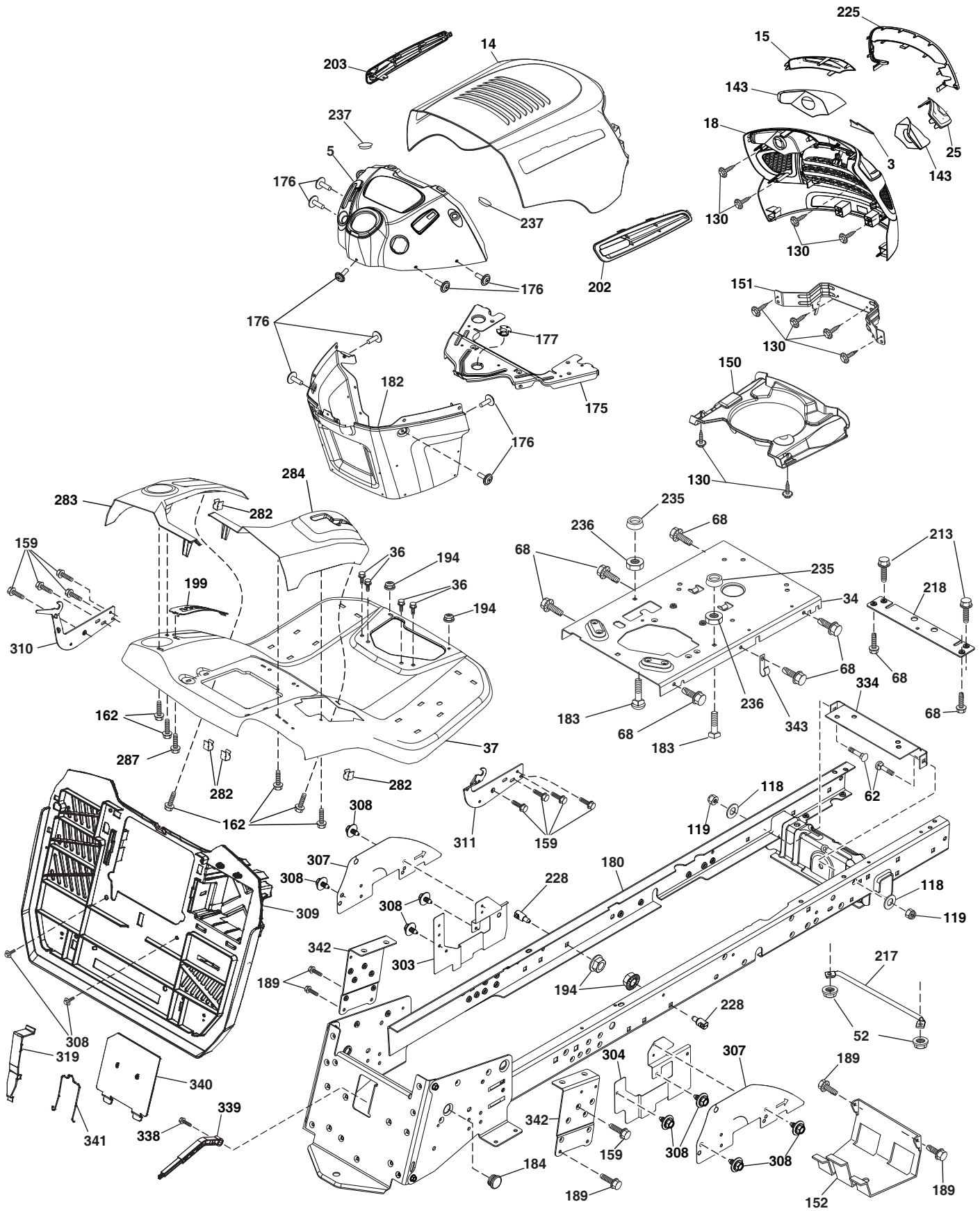

chassis-tex crd_TEX LT PRED_17

**TRACTOR - MODEL NO. M115-97TC (96051013200), PROD. NO. 960 51 01-32
CHASSIS AND ENCLOSURES 39**

KEY NO.	PART NO.	DESCRIPTION	KEY NO.	PART NO.	DESCRIPTION
3	578 89 71-01	Emblem Mount	213	874 76 05-12	Bolt 5/16-18 x 3/4
5	532 40 95-97	Dash	217	532 40 91-67	Rod Pivot Hood
14	581 56 47-01	Hood	218	532 19 63-95	X-Piece Hood Stop
15	581 05 58-01	Lens LH	225	581 05 62-01	Trim Ring
18	581 05 57-01	Grille	228	532 19 51-61	Stud Fastener
25	581 05 59-01	Lens RH	235	532 40 61-29	Spacer Fender
34	580 91 09-01	Plate Engine	236	873 93 05-00	Nut Lock 5/16-18 unc
36	817 06 05-12	Screw 5/16-18 x 3/4	237	532 40 37-04	Plug Mount Cargo
37	532 44 08-49	Fender	282	532 41 41-10	Clip Retainer
52	873 68 05-00	Nut Crown Lock 5/16	283	532 44 03-61	Console Deck Lift
62	872 11 06-08	Bolt 3/8-16 x 1 Gr. 5	284	532 44 05-28	Console Shift RH
68	817 49 05-08	Screw Thdrol. 5/16-18 x 1/2	287	817 60 04-06	Screw Hex Washhead 1/4-20 x 3/8
118	819 13 13-16	Washer 13/32 x 13/16 x 16 Ga.	303	587 49 31-01	Shield LH
119	873 68 06-00	Nut 3/8-16 unc	304	587 49 33-01	Shield RH
130	532 41 63-58	Screw #10 x 0.750 BOS Thread	307	587 49 45-01	Shield Upper
143	581 05 60-02	Insert Reflective LH/RH	308	532 17 18-77	Bolt 5/16-18 unc x 3/4
150	532 40 02-67	Duct, Air	309	584 44 11-01	Backplate Bagger
151	532 18 75-68	Bracket Pivot Hood	310	532 44 54-24	LH Adjust Hanger
152	532 19 95-35	Shield Browning	311	532 44 54-29	RH Adjust Hanger
159	817 00 06-12	Screw Hexwsh Thdr 3/8-16 x 3/4	319	532 17 46-62	Lever Bagger
162	532 14 24-32	Screw Hex Wsh. Hi-Lo 1/4 x 1/2 unc	334	532 44 25-37	Engine Plate
175	532 19 94-72	Crossmember	338	532 43 66-40	Bolt Shoulder
176	532 40 07-76	Screw 10-24 x 5/8	339	532 43 66-41	Lever Bagger Full
177	532 19 52-28	Bushing Steering	340	532 44 09-31	Door Battery
180	581 18 71-01	Chassis	341	582 06 08-01	Latch Battery Door
182	532 40 71-76	Dash Lower	342	532 43 59-38	Support Fender
183	874 52 05-20	Bolt 5/16-18 x 1-1/4	343	532 44 07-49	Clip
184	587 63 36-01	Plug End			
189	817 00 05-12	Screw 5/16-18 x 3/4			
194	873 90 05-00	Nut Lock Hex Flange 5/16-18			
199	532 41 87-39	Plate Deck Lift			
202	581 56 49-01	Vent Hood RH			
203	581 56 48-01	Vent Hood LH			

NOTE: All component dimensions given in U.S. inches
1 inch = 25.4 mm

TRACTOR - MODEL NO. M115-97TC (96051013200), PROD. NO. 960 51 01-32
DRIVE **40**

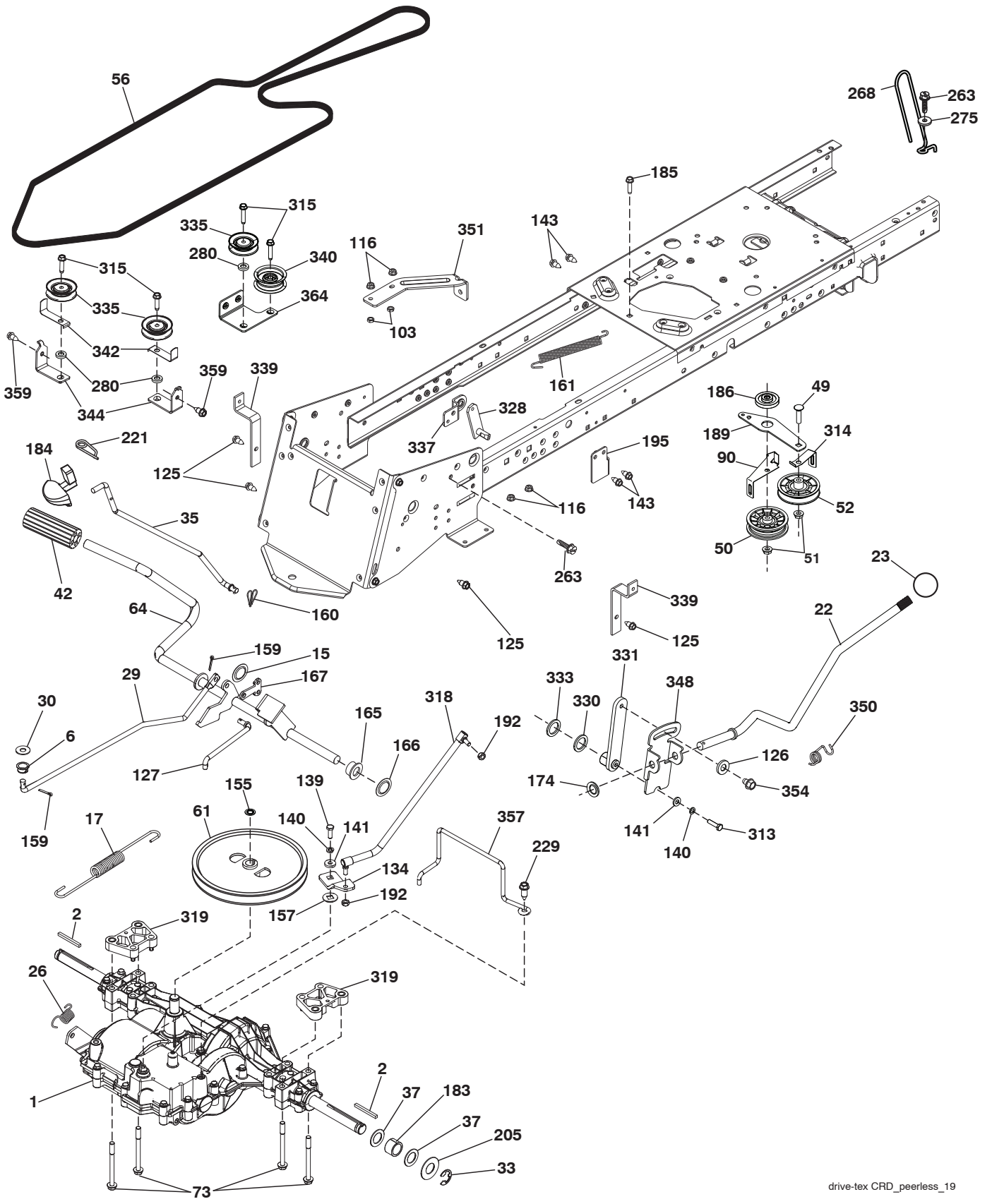

drive-tex CRD_peerless_19

**TRACTOR - MODEL NO. M115-97TC (96051013200), PROD. NO. 960 51 01-32
DRIVE **40****

KEY NO.	PART NO.	DESCRIPTION	KEY NO.	PART NO.	DESCRIPTION
1	---	Transaxle, Peerless 206-578 (436815) (Order parts from transaxle manufacturer.)	174	532 19 72-89	Nut Push
2	532 12 35-83	Key Square	183	532 13 70-57	Spacer Axle
6	532 12 40-28	Bushing	184	532 41 14-84	Handle Parking Brake
15	819 13 13-16	Washer 13/32 x 13/16 x 16 Ga.	185	872 11 06-22	Bolt
17	532 44 08-67	Spring, Brake	186	532 19 43-21	Spacer Retainer
22	532 44 32-46	Rod Shift CRD Tex	189	532 43 36-11	Bellcrank Ground Drive CRD Tex
23	532 10 69-33	Knob 1/2-13	192	532 15 03-60	Nut Lock Center 1/4-28 Fnthd.
26	532 14 66-82	Spring Brake Return	195	580 45 69-01	Bracket Brake Rod
29	532 43 70-16	Rod, Brake	205	532 12 17-48	Washer 25/32 x 1-5/8 16 Ga.
30	819 13 16-16	Washer	221	532 40 31-87	Retainer Spring Clip Handle
33	812 00 00-01	Ring E	229	817 06 05-16	Screw
35	532 40 10-31	Rod, Brake, Park	263	817 00 06-12	Screw
37	532 12 17-49	Washer 25/32 x 1-1/4 x 16 Ga.	268	532 18 24-02	Guard Muffler RH
42	532 12 48-72	Cover, Foot Pedal	275	819 13 16-14	Washer 13/32 x 1 x 14 Ga.
49	872 11 06-14	Bolt	280	819 11 10-12	Washer
50	532 19 43-27	Idler Flat	313	874 78 04-16	Bolt Hex Fin 1/4-20 x 1 Gr. 5
51	873 90 06-00	Lock Nut 3/8-16	314	532 44 47-13	Keeper, Belt
52	532 19 43-26	Pulley Idler V Groove Plastic	315	817 58 05-20	Screw Thdrol 5/16-18 x 4.25
56	532 43 63-84	V-Belt, Drive	318	532 43 70-22	Link Shift Gear
61	532 16 59-99	Pulley Transaxle	319	532 43 67-94	Spacer Transaxle Tex CRD
64	532 19 62-00	Shaft Asm. Pedal Brake Control	328	532 43 79-58	Shaft Shift Front
73	874 49 05-56	Bolt Hex 5/16-18 x 3.75	330	532 16 95-93	Washer Nylon
90	532 44 36-05	Keeper Belt Clutching	331	532 44 36-06	Hub Shift
103	873 35 05-00	Nut	333	532 17 08-68	Wave Spring Washer
116	873 90 05-00	Nut Lock Hex Flange 5/16-18	335	532 19 95-34	Pulley V-Idler
125	817 00 05-12	Screw 5/16-18 x 3/4	337	532 43 59-37	Bracket Supt Shift CRD Tex
126	532 16 60-02	Washer Srrtd 5/16 ID x 1.0 x .125	339	532 43 68-67	Strap Torque K46 CRD Tex
127	582 21 70-01	Link Clutch Ground Drive, Long	340	532 43 68-12	Idler Flat
134	532 14 50-90	Asm. Shift	342	532 18 26-82	Keeper Belt
139	874 55 04-12	Bolt 1/4-28 unf Gr. 8 w/Patch	344	532 43 56-45	Bracket Idler CRD Tex
140	810 04 04-00	Washer Lock Hvy. Helical 1/4	348	532 44 36-07	Bracket Pivot Lever
141	819 09 12-10	Washer 9/32 x 3/4 x 10 Ga.	350	532 44 50-20	Spring Torsion Shift
143	817 49 05-08	Screw Thdrol 5/16-18 x 1/2 TYTT	351	532 43 69-98	Bracket Deck Sway
155	812 00 00-28	Ring Retainer	354	817 49 05-10	Screw
157	532 10 57-01	Washer Plate Shift	357	532 44 13-38	Keeper Belt Transmission
159	876 02 04-12	Cotter Pin	359	817 49 06-10	Screw Hxwsh Thdr 3/8-16 x 5/8
160	532 16 94-84	Retainer Clip	364	532 44 30-32	Bracket
161	532 10 57-09	Spring, Return, Clutch			
165	532 19 62-12	Bushing Shaft Brake Hand Control			
166	532 42 91-64	Nut Push .625			
167	532 40 52-57	Latch Brake Parking			

NOTE: All component dimensions given in U.S. inches
1 inch = 25.4 mm

TRACTOR - MODEL NO. M115-97TC (96051013200), PROD. NO. 960 51 01-32
ENGINE 24

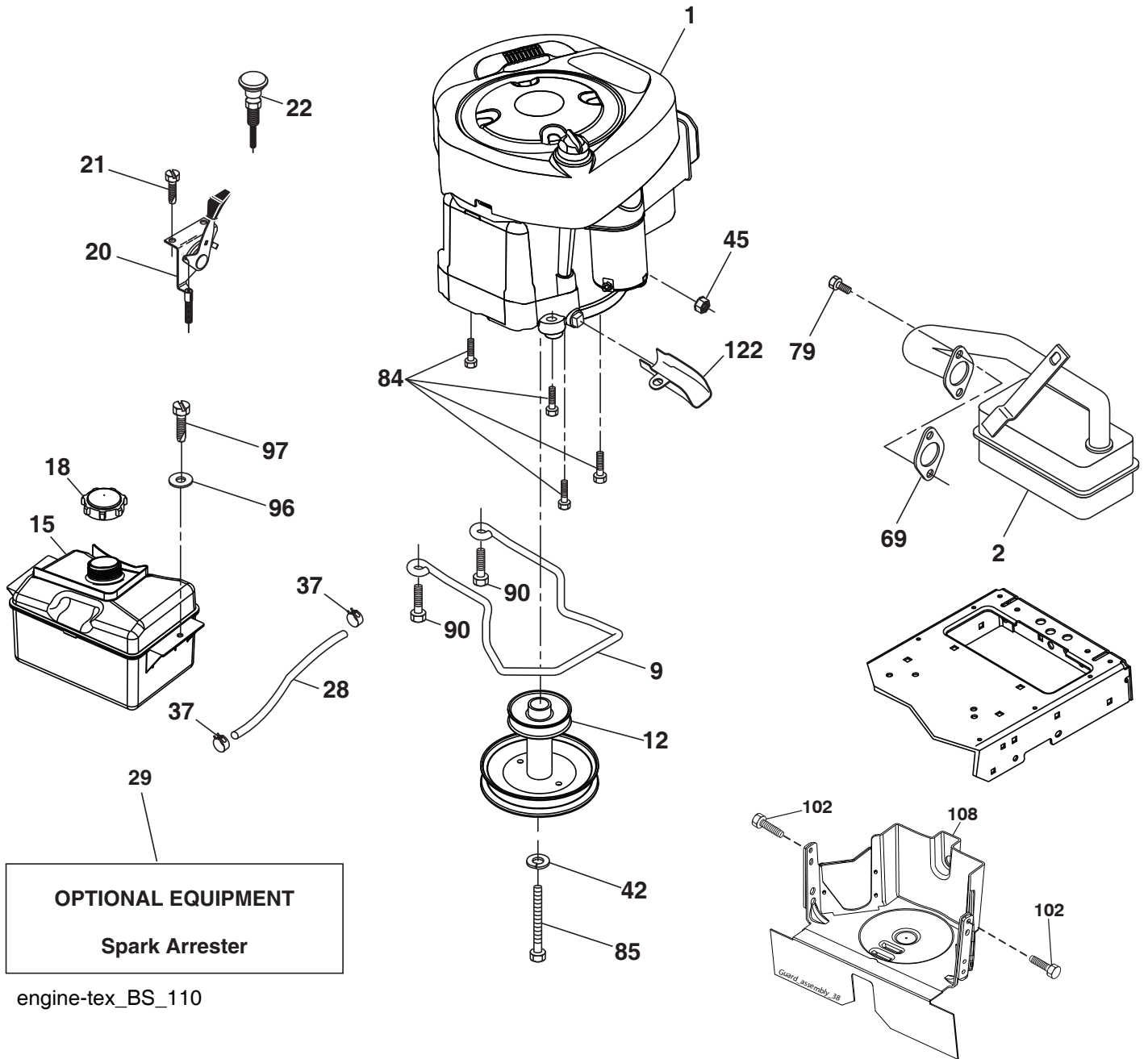

engine-tex_BS_110

**TRACTOR - MODEL NO. M115-97TC (96051013200), PROD. NO. 960 51 01-32
ENGINE 24**

KEY NO.	PART NO.	DESCRIPTION
1	— — — — —	Engine Briggs Model 21R607-0011-H1 (585700201) (Order parts from engine manufacturer.)
2	532 17 97-58	Muffler
9	501 83 26-01	Keeper Belt Engine
12	586 47 85-01	Pulley Engine
15	581 28 99-01	Tank Fuel
18	532 43 02-20	Cap Fuel
20	532 18 38-97	Control Throttle/Choke
21	532 41 63-58	Screw #10 x 0.750
22	532 19 49-81	Control Choke
28	532 13 70-40	Line Fuel
29	532 13 71-80	Kit Spark Arrester (Flat Scrn)
37	532 12 34-87	Clamp Hose Blk
42	810 04 07-00	Washer Lock 7/16
45	873 51-04-00	Nut Keps Hex 1/4-20 unc
69	532 16 52-91	Gasket Muffler
79	532 19 23-34	Screw 5/16-18 x .75
84	817 06 06-20	Screw 3/8-16 x 1-1/4
85	532 17 39-37	Bolt 7/16-20 x 4 x Gr. 5-1.5 THR
90	817 00 06-16	Screw 3/8-16 x 1
96	819 09 14-16	Washer 9/32 x 7/8 x 16 Ga.
97	817 67 04-12	Screw Hexwsh Thdrol 1/4-20 x 3/4
102	817 06 05-16	Screw
108	587 17 95-02	Cover Pulley Engine w/SHLD
122	532 42 19-22	Extension Drain Oil

NOTE: All component dimensions given in U.S. inches
1 inch = 25.4 mm

Engine Power Rating Information

The gross power rating for individual gas engine models is labeled in accordance with SAE (Society of Automotive Engineers) code J1940 (Small Engine Power & Torque Rating Procedure), and rating performance has been obtained and corrected in accordance with SAE J1995 (Revision 2002-05). Torque values are derived at 3060 RPM; horsepower values are derived at 3600 RPM. Actual gross engine power will be lower and is affected by, among other things, ambient operating conditions and engine-to-engine variability. Given both the wide array of products on which engines are placed and the variety of environmental issues applicable to operating the equipment, the gas engine will not develop the rated gross power when used in a given piece of power equipment (actual “on-site” or net power). This difference is due to a variety of factors including, but not limited to, accessories (air cleaner, exhaust, charging, cooling, carburetor, fuel pump, etc.), application limitations, ambient operating conditions (temperature, humidity, altitude), and engine-to-engine variability. Due to manufacturing and capacity limitations, Briggs & Stratton may substitute an engine of higher rated power for this Series engine.

TRACTOR - MODEL NO. M115-97TC (96051013200), PROD. NO. 960 51 01-32
STEERING ASSEMBLY [41]

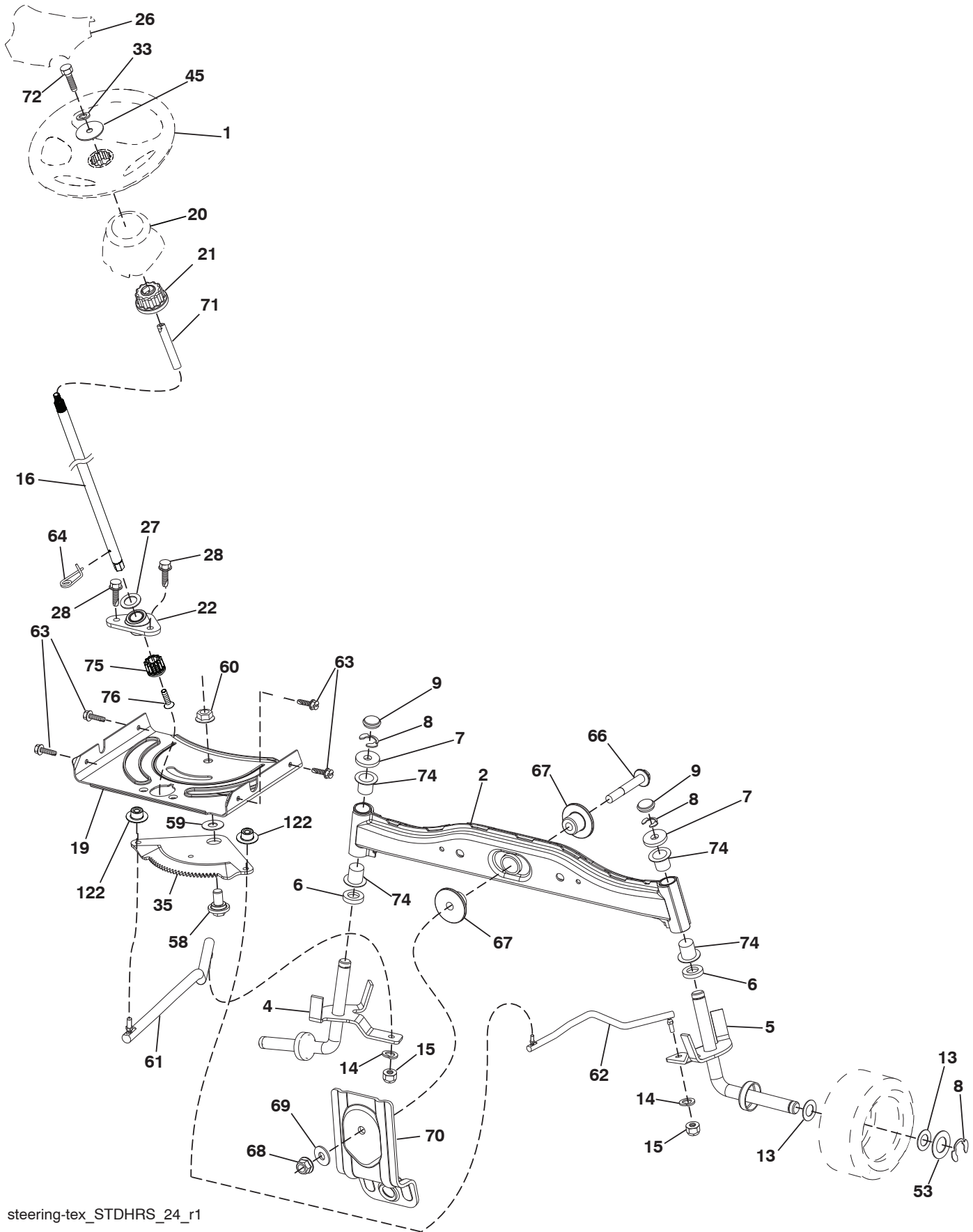

steering-tex_STDHRS_24_r1

TRACTOR - MODEL NO. M115-97TC (96051013200), PROD. NO. 960 51 01-32
STEERING ASSEMBLY 41

KEY NO.	PART NO.	DESCRIPTION
1	532 44 28-04	Wheel, Steering
2	532 41 81-68	Axle Asm.
4	532 40 30-87	Spindle Asm., LH
5	532 40 30-88	Spindle Asm., RH
6	532 12 49-31	Bearing, Race Thrust Harden
7	532 12 17-48	Washer 25/32 x 1-5/8 x 16 Ga.
8	812 00 00-29	Ring, Klip #T5304-75
9	532 12 12-32	Cap, Spindle
13	532 12 17-49	Washer 25/32 x 1-1/4 x 16 Ga.
14	810 04 06-00	Washer, Lock Hvy Hlcl Spr 3/8
15	873 54 06-00	Nut, Crown Lock 3/8-24 unf
16	585 86 92-02	Steering Shaft
19	532 19 47-29	Plate Steering
20	532 40 97-63	Boot, Steering
21	532 18 67-37	Adapter, Wheel Steering
22	585 02 98-02	Bearing
26	532 44 77-59	Insert, Wheel Steering
27	819 21 16-16	Washer 21 x 32 x 1 x 16 Ga.
28	817 00 06-12	Screw 3/8-16 x 3/4
33	810 04 05-00	Washer Lock 5/16
35	532 19 47-32	Gear, Sector Plate
45	819 11 38-12	Washer 11/32 x 3/8 x 12 Ga.
53	532 18 89-67	Washer Hardened .793 x 1.637 x .060
58	532 19 47-47	Bolt Shoulder Sector Pivot CFM
59	532 19 47-48	Washer Thrust Sector Steering
60	873 97 10-00	Nut Flange Lock 5/8-11
61	532 19 47-40	Draglink, LH
62	532 19 47-41	Draglink, RH
63	817 00 05-12	Screw 5/16-18 x 3/4
64	532 19 98-49	Retainer Clip Spring Steering
66	871 02 07-48	Bolt Hex Fghd 7/16-14 x 3 Serr
67	532 19 47-37	Bushing PM Front Axle
68	873 90 07-00	Nut Lock Flange 7/16-14 Gr. 5
69	532 19 91-62	Washer 1.5 x .505 x .118
70	585 33 88-01	Bracket Deck Susp. Front
71	532 19 07-52	Shaft Extension Steering
72	532 42 89-82	Bolt Fin Hx 5/16-18 x 4
74	532 12 49-37	Bearing
75	580 68 37-01	Pinion
76	580 68 36-01	Screw Head Sock
122	532 44 49-62	Cap Gear Sector

NOTE: All component dimensions given in U.S. inches
1 inch = 25.4 mm

TRACTOR - MODEL NO. M115-97TC (96051013200), PROD. NO. 960 51 01-32
MOWER DECK 44

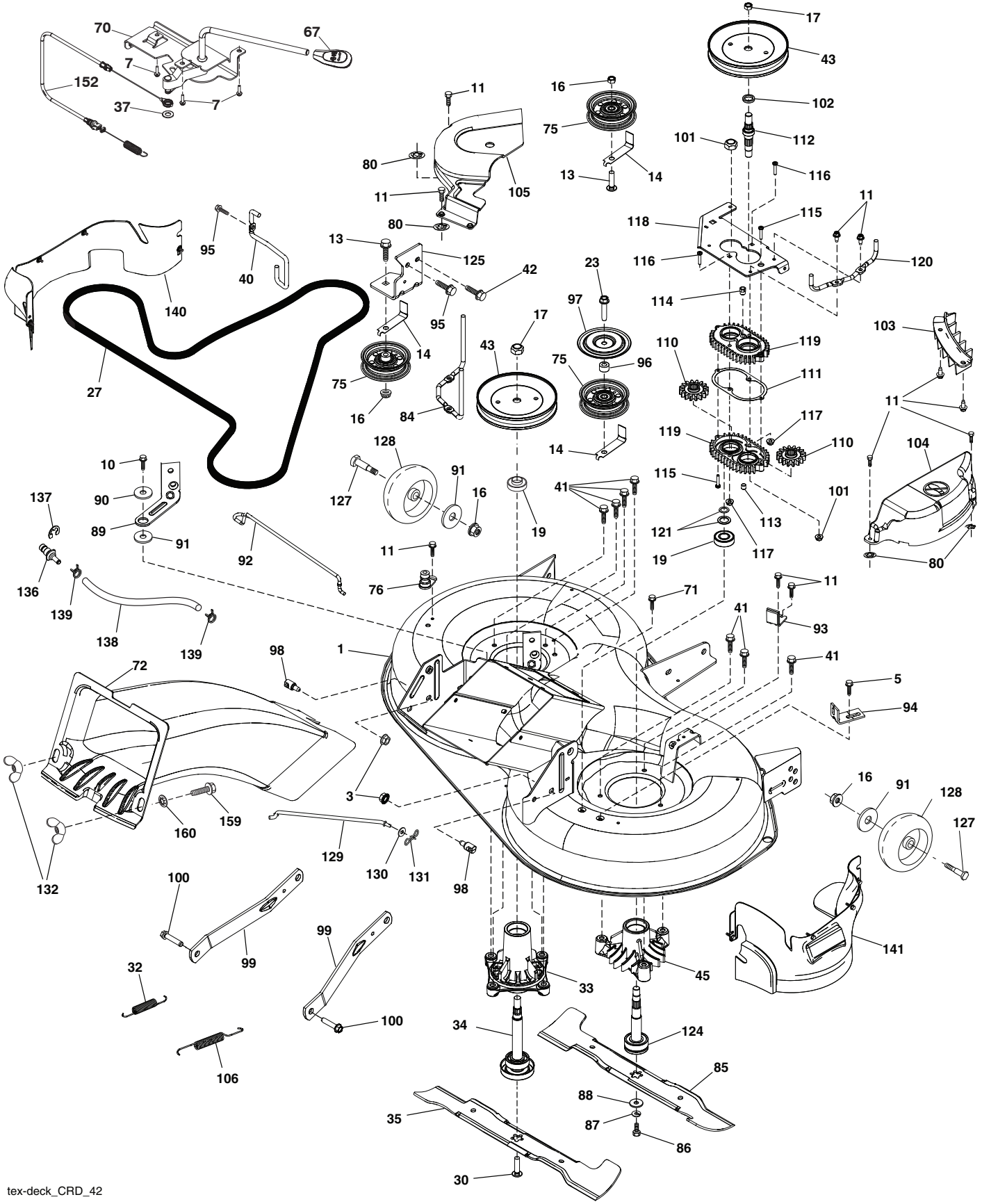

tex-deck_CRD_42

TRACTOR - MODEL NO. M115-97TC (96051013200), PROD. NO. 960 51 01-32
MOWER DECK 44

KEY NO.	PART NO.	DESCRIPTION	KEY NO.	PART NO.	DESCRIPTION
1	532 43 69-70	Deck Weldment	110	587 93 48-01	Gear Output
3	873 90 05-00	Nut Lock Hex Flange 5/16 - 18	111	532 43 69-79	Gasket Gearcase
5	817 00 05-10	Bolt 5/16-18	112	532 44 38-52	Shaft Gearcase Adapter
7	532 41 63-58	Screw #10 x 0.750 BOS Thread	113	532 43 85-33	Plug Oil
10	817 00 06-16	Screw 3/8-16x1 smgml tap	114	588 17 05-01	Valve Relief
11	532 13 77-29	Screw Thd Roll 1/4 - 20 X 5/8	115	818 03 10-16	Screw Torx #10-24 x 1
13	872 11 06-12	Bolt Carr Sh 3/8 - 16 X 1-1/2 Gr. 5	116	872 11 04-14	Bolt 1/4-20 x 1.75 Gr. 5
14	532 15 60-85	Keeper Belt Idler	117	873 90 04-00	Nut Hex Flange 1/4-20 unc
16	873 90 06-00	Nut Lock FIG 3/8 - 16 unc	118	532 43 69-89	Arm Clutching
17	532 40 02-34	Nut Flange Lock Top	119	532 43 81-66	Gearcase Subasm
19	585 32 39-01	Bearing Mandrel	120	532 43 69-91	Keeper Belt RH
23	817 49 06-28	Screw Thdrol 3/8 - 16 X 1-3/4	121	532 43 69-85	Washer
27	532 43 97-26	V-Belt Drive	124	532 43 69-86	Non Greasable Mandrel Shaft
30	584 30 93-01	Screw	125	532 44 04-20	Bracket Idler Chassis
32	532 40 18-72	Spring Return Deck	127	532 19 34-06	Bolt Shoulder 3/8-16 x 3-5/8 Gr. 5
33	532 18 72-81	Housing Mandrel 4pt Service	128	532 17 48-73	Wheel Gauge
34	587 25 65-01	Shaft Asm Mndrl	129	532 40 48-51	Rod Anti-Sway
35	532 42 79-84	Blade Mower LH	130	819 13 13-12	Washer 13/32 x 13/16 x 12 Ga.
37	819 13 13-16	Washer 13/32 x 13/16 x 16 Ga.	131	532 19 42-08	Pin Cotter 5/16 Bow Tie Lock
40	532 19 72-58	Keeper Belt Engine LH	132	532 17 88-99	Knob Handle 3/8-16
41	584 95 39-01	Bolt Hex Wsh Hd .313-18 x 1.19	136	532 43 96-39	Washout Port
42	817 00 05-12	Screw 5/16-18 x 3/4	137	812 00 00-29	Ring Clip
43	532 19 74-73	Pulley Mandrel	138	532 44 07-43	Hose
45	532 13 71-52	Housing Mandrel	139	532 44 07-42	Hose Clamp
67	532 40 30-12	Handle Clutch Cable	140	501 57 94-01	LH Guard
70	532 40 12-46	Clutch Asm Manual LT Pred	141	501 57 93-02	RH Guard
71	817 67 06-08	Screw 3/8-16 x 1/2	152	532 44 04-88	Cable Clutch Manual w/Spring
72	582 03 56-01	Chute Upper	159	872 14 06-14	Bolt 3/8-16 unc x 1-3/4
75	532 13 14-94	Pulley Idler Flat	160	532 16 89-37	Nut Push
76	532 43 96-40	Washout Port	--	587 25 33-01	MANDREL ASSEMBLY (Includes Housing Assembly (key#33), Shaft Assembly (key#34) and Bearing Only (key#19) - Pulley/ Nut/Washer And Blade Bolt/ Washers Not Included)
80	532 42 30-62	Pal Nut	--	532 44 86-41	Replacement Mower Complete
84	532 43 25-20	Keeper Belt LH Mandrel	--	532 44 81-32	Gear Case Kit - Use .75 oz. Shell 460 oil (Include Gear Output (key #110), Gasket Gearcase (key #111), Shaft Gearcase (key #112), Plug Oil (key #113), Vent Breather 1/8 NPT (key #114), Screw Torx (key #115), Gearcase Subasm (key #119))
85	532 42 79-85	Blade Mower RH			
86	532 18 17-13	Bolt 3/8-24 x 1.50 Gr. 8			
87	810 03 06-00	Washer Lock Hvy. 3/8			
88	532 14 02-96	Washer Hard			
89	532 43 81-24	Arm Brake 97 LH			
90	532 19 90-92	Spacer Retainer			
91	819 13 20-12	Washer 13/32 x 1-1/4 x 12 Ga.			
92	532 43 69-93	Rod Brake Assembly			
93	532 43 81-25	Arm Brake RH			
94	532 19 72-50	Bracket Clutch Cable			
95	817 00 06-12	Screw 3/8-16 x 3/4			
96	532 40 02-71	Spacer			
97	532 18 20-61	Shield Idler Mower			
98	532 19 51-61	Stud Fastener			
99	532 19 51-86	Arm Suspension Mower Rear			
100	532 19 65-39	Bolt Shoulder			
101	873 68 09-00	Nut Crownlock 9/16 - 18 unc			
102	532 40 25-11	Spacer Bearing Swing Plate			
103	532 43 69-92	Guard Front Vent			
104	532 43 89-68	Mandrel Cover RH			
105	532 43 87-44	Mandrel Cover LH			
106	532 19 32-16	Spring Brake Return			

NOTE: All component dimensions given in U.S. inches
1 inch = 25.4 mm

TRACTOR - MODEL NO. M115-97TC (96051013200), PROD. NO. 960 51 01-32
MOWER LIFT 45

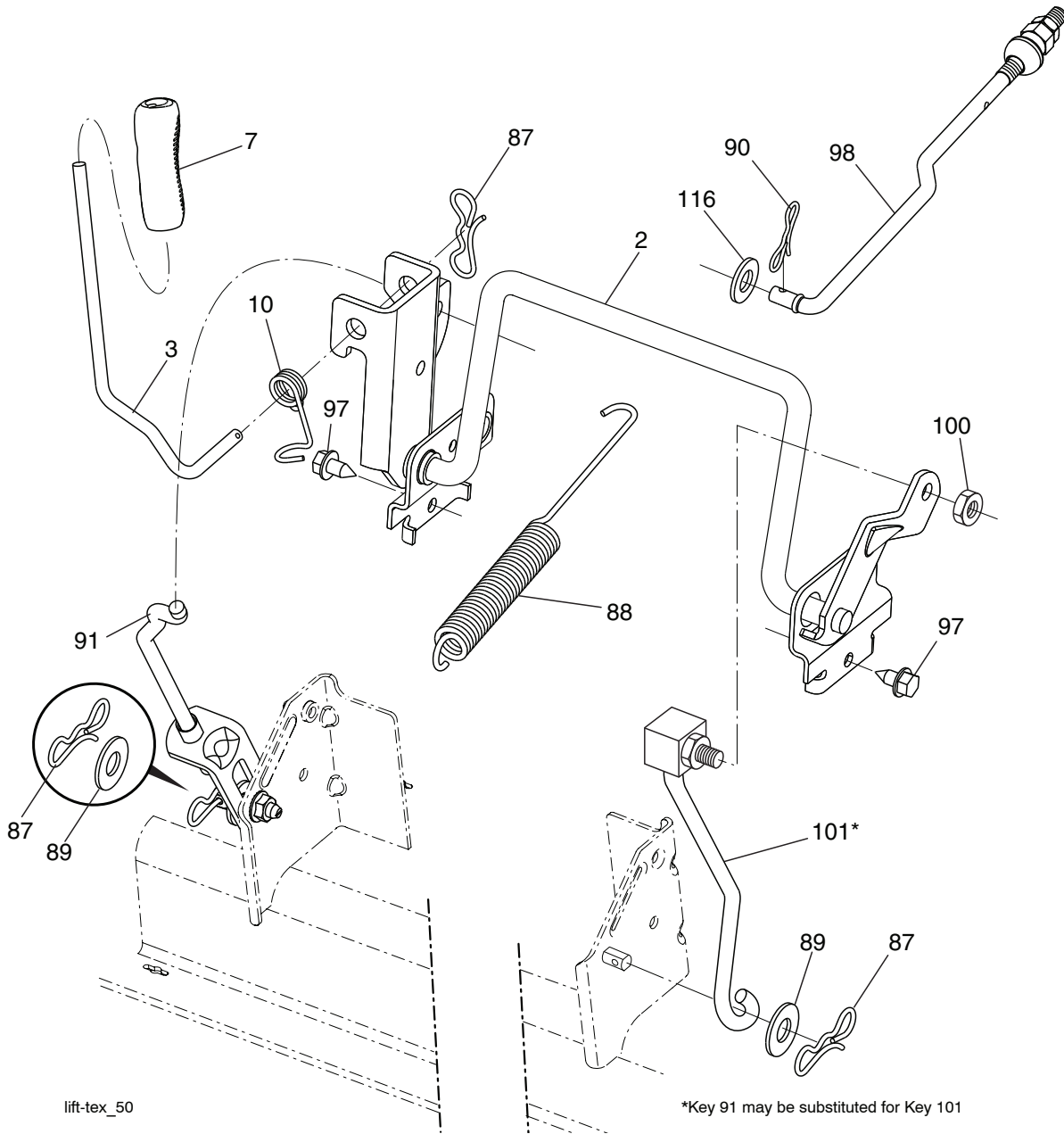

KEY NO.	PART NO.	DESCRIPTION
2	532 43 69-96	Deck Lift
3	532 19 52-31	Lever Asm., Lift RH
7	580 96 23-01	Grip, Lever
10	532 19 63-14	Spring Torsion
87	532 19 42-09	Pin Cotter 7/16 Bow Tie Lock
88	532 43 69-95	Spring Lift Assist
89	819 19 19-12	Washer 17/32 x 1-3/16 x 12 Ga.
90	532 19 42-08	Pin Cotter 5/16 Bow Tie Lock
91	532 19 51-81	Link Lift Susp Mower Rear

KEY NO.	PART NO.	DESCRIPTION
97	817 49 06-08	Screw 3/8-16 x 1/2
98	532 19 52-70	Link Lift Susp. Front Mower
100	873 93 06-00	Nut Centerlock 3/8-16
101	532 40 70-03	Link Asm Lift FXD
116	819 15 15-16	Washer 15/32 x 15/16 x 16 Ga.

NOTE: All component dimensions given in U.S. inches
 1 inch = 25.4 mm

TRACTOR - MODEL NO. M115-97TC (96051013200), PROD. NO. 960 51 01-32
SEAT ASSEMBLY 42

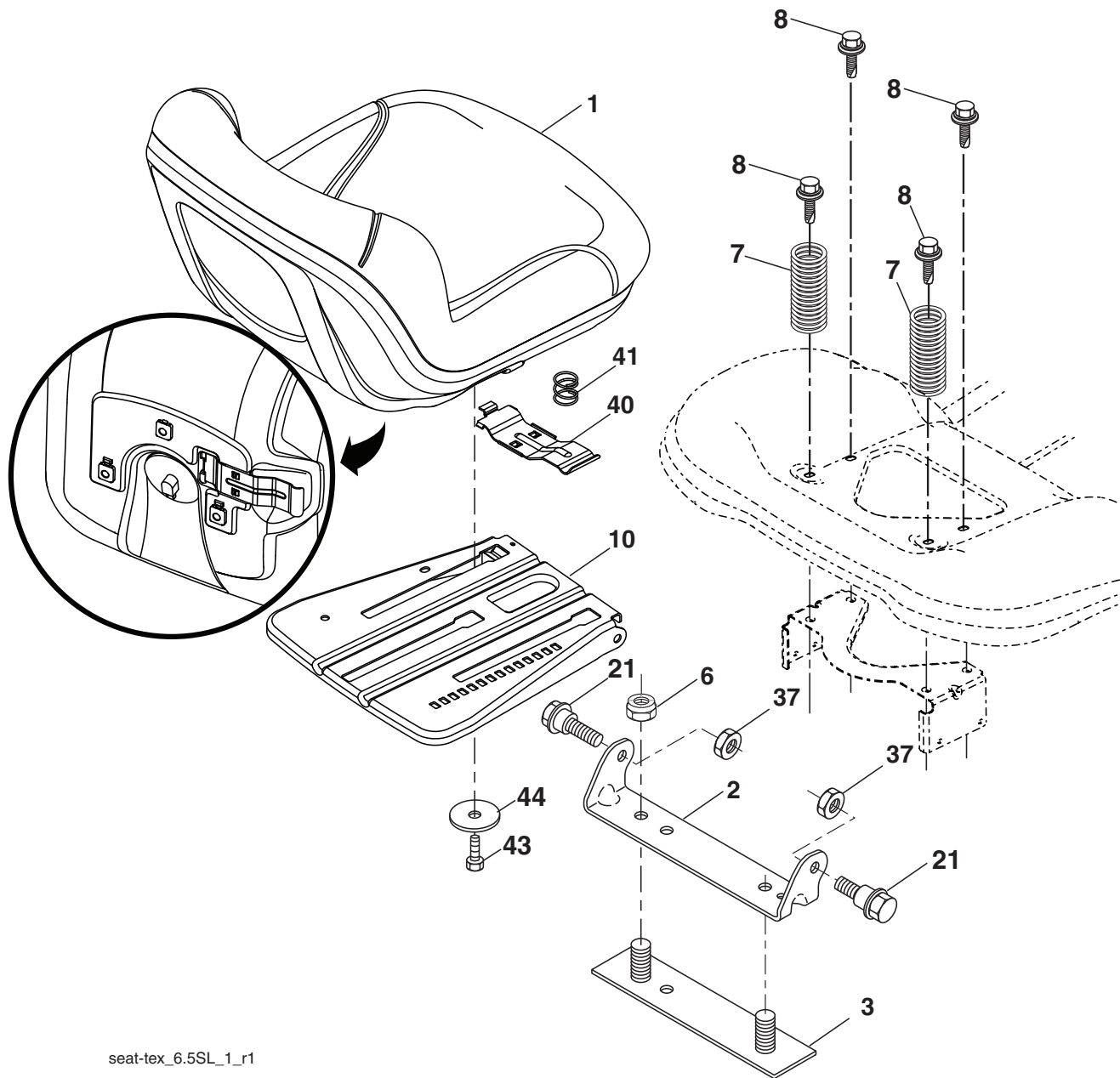

seat-tex_6.5SL_1_r1

KEY NO.	PART NO.	DESCRIPTION
1	581 46 20-01	Seat
2	532 18 01-66	Bracket Pnt Pivot Fender
3	532 14 06-75	Strap
6	873 80 06-00	Nut Lock Hex w/Ins 3/8-16
7	532 12 41-81	Spring Seat Cprsn 2 250 Blk Zi
8	532 17 18-77	Bolt 5/16-18 unc x 3/4
10	532 19 69-77	Pan Pnt Seat
21	532 17 18-52	Bolt Shoulder 5/16-18 unc-2A
37	873 80 05-00	Nut Hex Lock w/Ins 5/16-18

KEY NO.	PART NO.	DESCRIPTION
40	532 19 76-61	Handle Slide
41	532 19 82-00	Spring Latch
43	874 76 06-12	Bolt 3/8-16 unc x 3/4
44	819 13 38-12	Washer 13/32 x 2-3/8 x 12 Ga.

NOTE: All component dimensions given in U.S. inches
 1 inch = 25.4 mm

TRACTOR - MODEL NO. M115-97TC (96051013200), PROD. NO. 960 51 01-32
BAGGER **46**

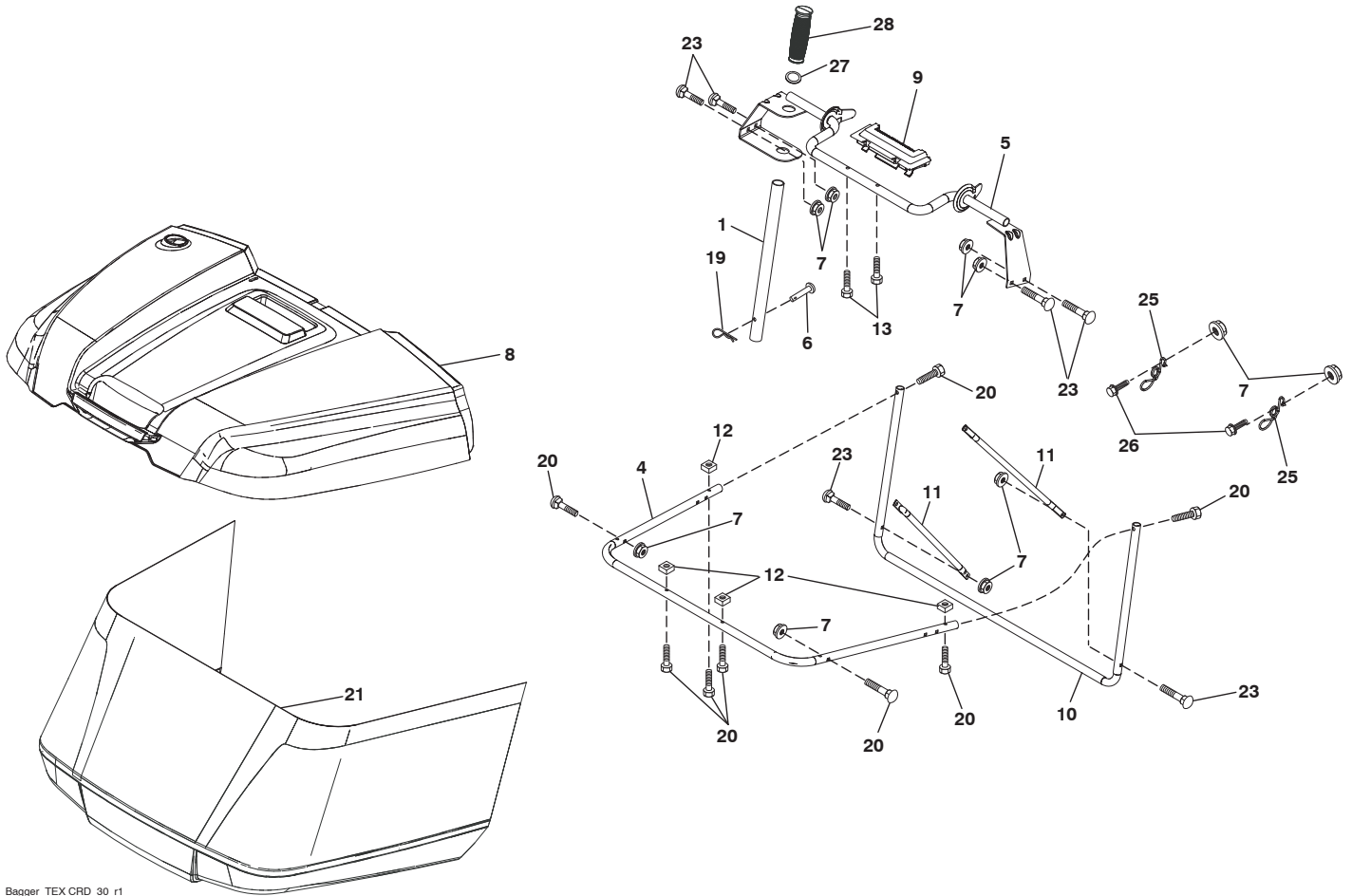

Bagger_TEX CRD_30_r1

**TRACTOR - MODEL NO. M115-97TC (96051013200), PROD. NO. 960 51 01-32
BAGGER 46**

KEY NO.	PART NO.	DESCRIPTION
1	532 42 86-10	Tube Handle Bagger
4	579 78 54-01	Frame Asm Bagger Top
5	532 41 76-32	Frame Asm Top Bagger
6	532 12 68-75	Rivet Drilled
7	873 90 04-00	Nut Hex Flange 1/4-20 unc
8	532 42 59-54	Cover Bagger
9	532 41 76-29	Insert Handle Bagger
10	532 43 67-70	Frame Front
11	532 43 67-71	Tubing Brace Bagger
12	532 42 17-93	Nut Square 1/4
13	532 42 17-80	Screw 1/4 x 1.150
19	532 19 42-08	Cotter Pin 5/16 Bow Tie
20	501 40 66-01	Screw Hex Cap 1/4-20 x 1.500
21	581 33 70-01	Bag Asm
23	872 04 04-10	Bolt Carr. 1/4-20
25	532 42 16-14	Spring Latch
26	817 49 04-12	Screw 1/4-20
27	532 42 12-62	Grommet Rubber
28	532 16 57-87	Grip Handle Black

NOTE: All component dimensions given in U.S. inches
1 inch = 25.4 mm

