

ILLUSTRATED PARTS LIST

MODEL NO. 96021000906

CUSTOMER CATALOG NO. MOWCART 66

PRODUCT NO. 960 21 00-09

RIDING MOWER - - MODEL NO. MOWCART 66 (96021000906)

DECALS **27**

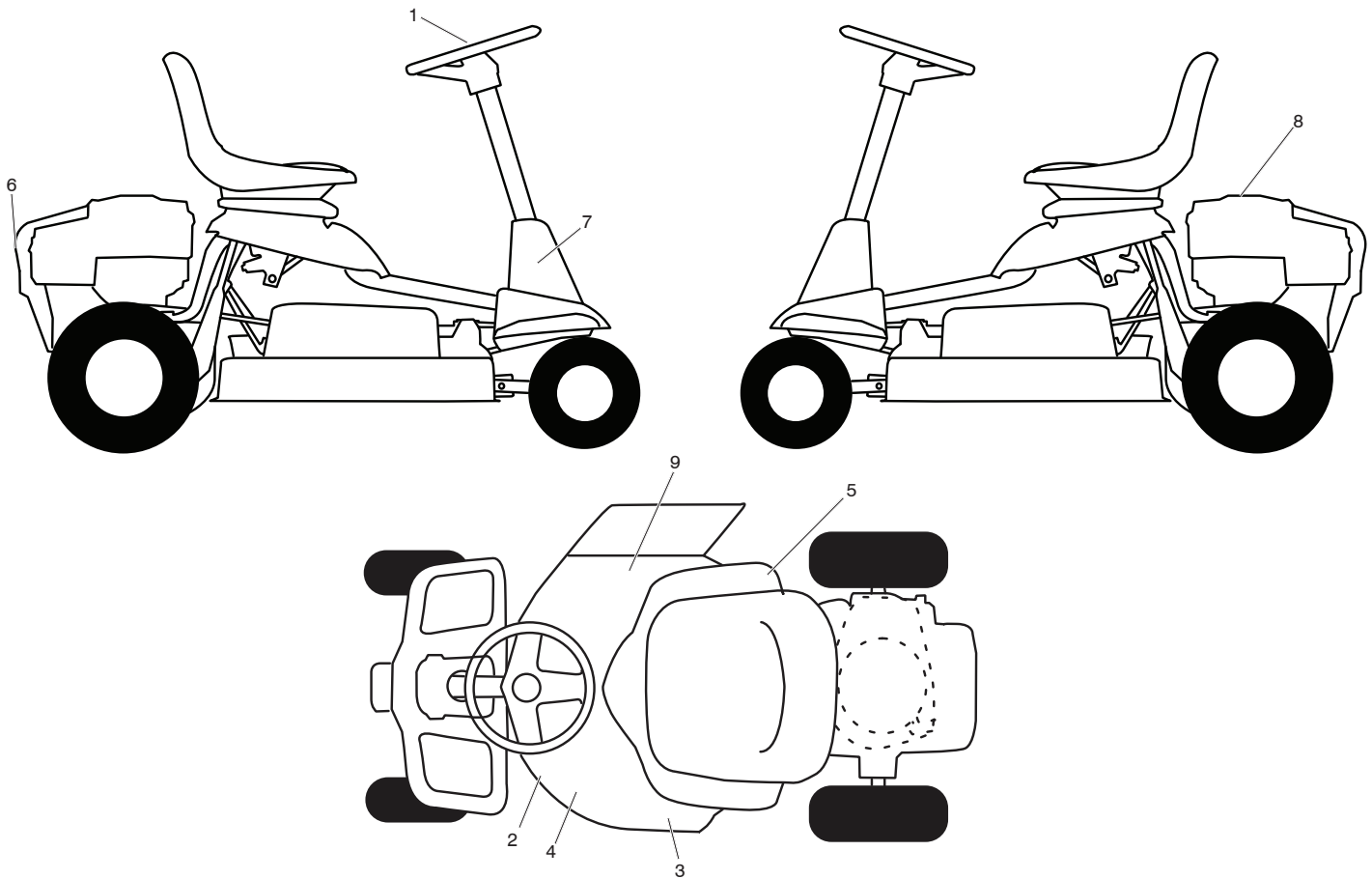

| KEY NO. | PART NO. | DESCRIPTION |
|---------|--------------|------------------------------|
| 1 | 532 43 79-66 | DECAL, STEERING WHEEL |
| 2 | 532 43 35-96 | DECAL, V-BELT SCH 26" |
| 3 | 581 57 94-01 | DECAL, WARN. DEFLECT/CTFGR |
| 4 | 532 43 67-16 | DECAL, DECK/DEFLECTOR |
| 5 | 532 43 67-56 | DECAL, WARNING CLUTCH |
| 6 | 532 43 73-11 | DECAL, WARNING |
| 7 | 532 43 73-12 | DECAL, INSTALL BOOT |
| 8 | 586 33 69-01 | DECAL, ENGINE |
| 9 | 584 90 46-01 | DECAL, DECK/DEFLECT. WARNING |
| -- | 532 43 24-79 | DECAL, BYPASS |
| -- | 587 41 26-28 | MANUAL OPERATOR ENGLISH |

NOTE: All component dimensions given in U.S. inches
1 inch = 25.4 mm

RIDING MOWER - - MODEL NO. MOWCART 66 (96021000906)

SCHEMATIC 38

SCH21

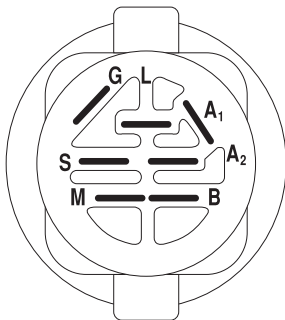
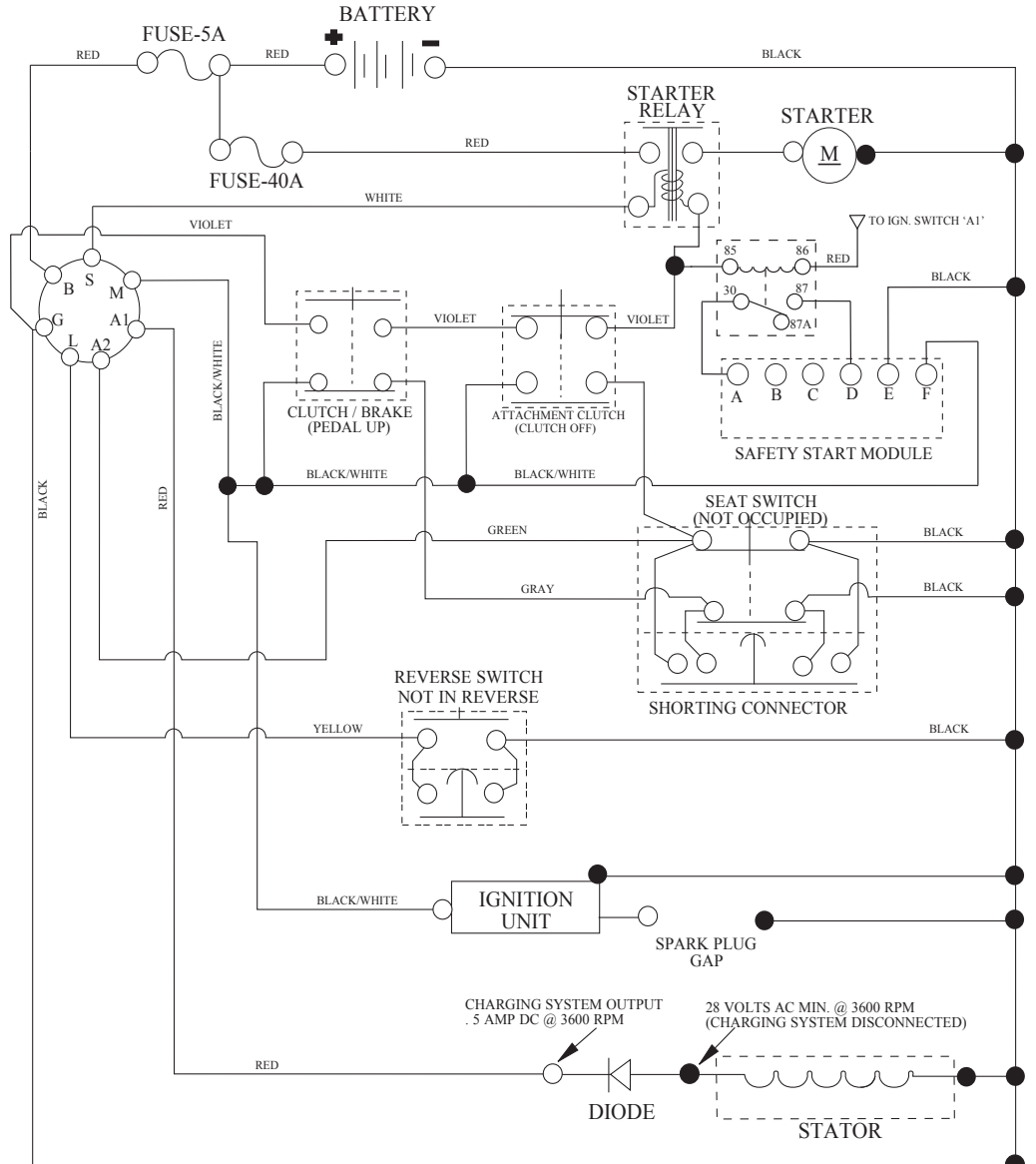

IGNITION SWITCH

| POSITION | CIRCUIT | "MAKE" |
|--------------|------------|--------|
| OFF | M+G+A1 | |
| RUN/OVERRIDE | B+A1 | |
| RUN | B+A1 | L+A2 |
| START | B + S + A1 | |

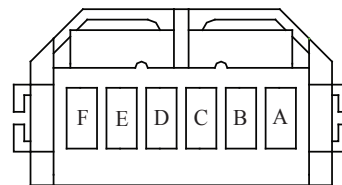

SAFETY START MODULE
VIEWED FROM MATING SIDE



NON-REMOVABLE
CONNECTIONS

WIRING INSULATED CLIPS
NOTE: IF WIRING INSULATED CLIPS
WERE REMOVED FOR SERVICING OF
UNIT, THEY SHOULD BE RE-INSTALLED
TO PROPERLY SECURE YOUR WIRING.

RIDING MOWER - - MODEL NO. MOWCART 66 (96021000906)

ELECTRICAL 32

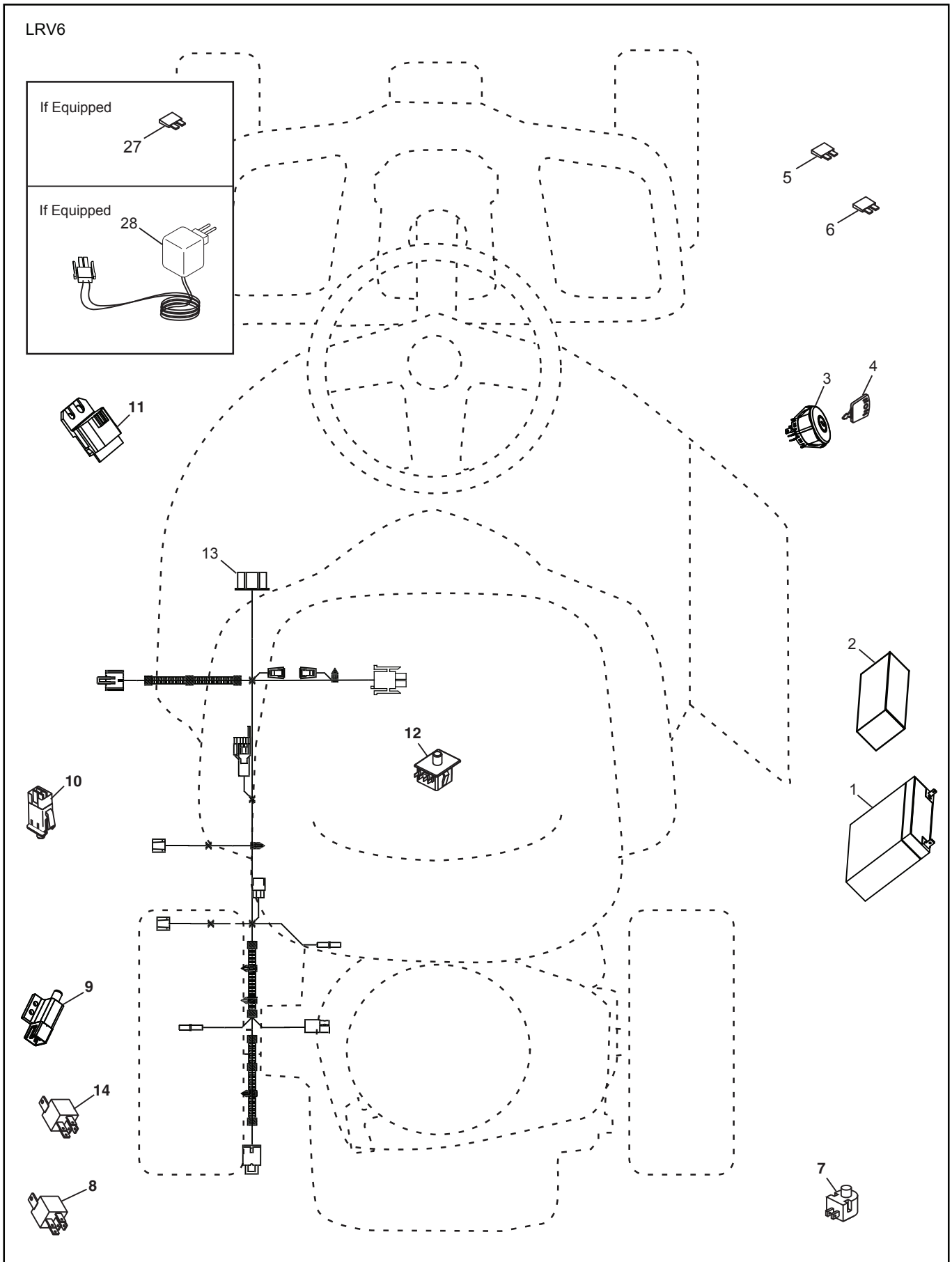

RIDING MOWER - - MODEL NO. MOWCART 66 (96021000906)

ELECTRICAL 32

| KEY NO. | PART NO. | DESCRIPTION |
|----------------|-----------------|-------------------------------|
| 1 | 580 76 49-01 | BATTERY, |
| 2 | 532 42 54-16 | FOAM, POLYURETHANE |
| 3 | 532 19 33-50 | SWITCH, IGN, DLTA, P-IN, ROS |
| 4 | 532 41 19-33 | KEY, MOLDED |
| 5 | 532 43 33-30 | FUSE, 5A |
| 6 | 532 42 59-37 | FUSE, 40A |
| 7 | 532 16 07-84 | SWITCH, PLUNGER, NO, OLIVE |
| 8 | 532 43 15-42 | RELAY, 40A |
| 9 | 532 10 95-53 | SWITCH, INTLK,CL, MWR, GRY |
| 10 | 532 17 61-38 | SWITCH, INTERLOCK, NONC,GRAY |
| 11 | 532 43 18-46 | MODULE, STARTING, RECOIL, LRV |
| 12 | 532 19 27-49 | SWITCH, SEAT, DP, ROS |
| 13 | 580 82 00-01 | HARNES, IGN, ELECTSTART, LRV |
| 14 | 532 10 97-48 | RELAY |

NOTE: All component dimensions given in U.S. inches
1 inch = 25.4 mm

RIDING MOWER - - MODEL NO. MOWCART 66 (96021000906)
CHASSIS AND ENCLOSURES 39

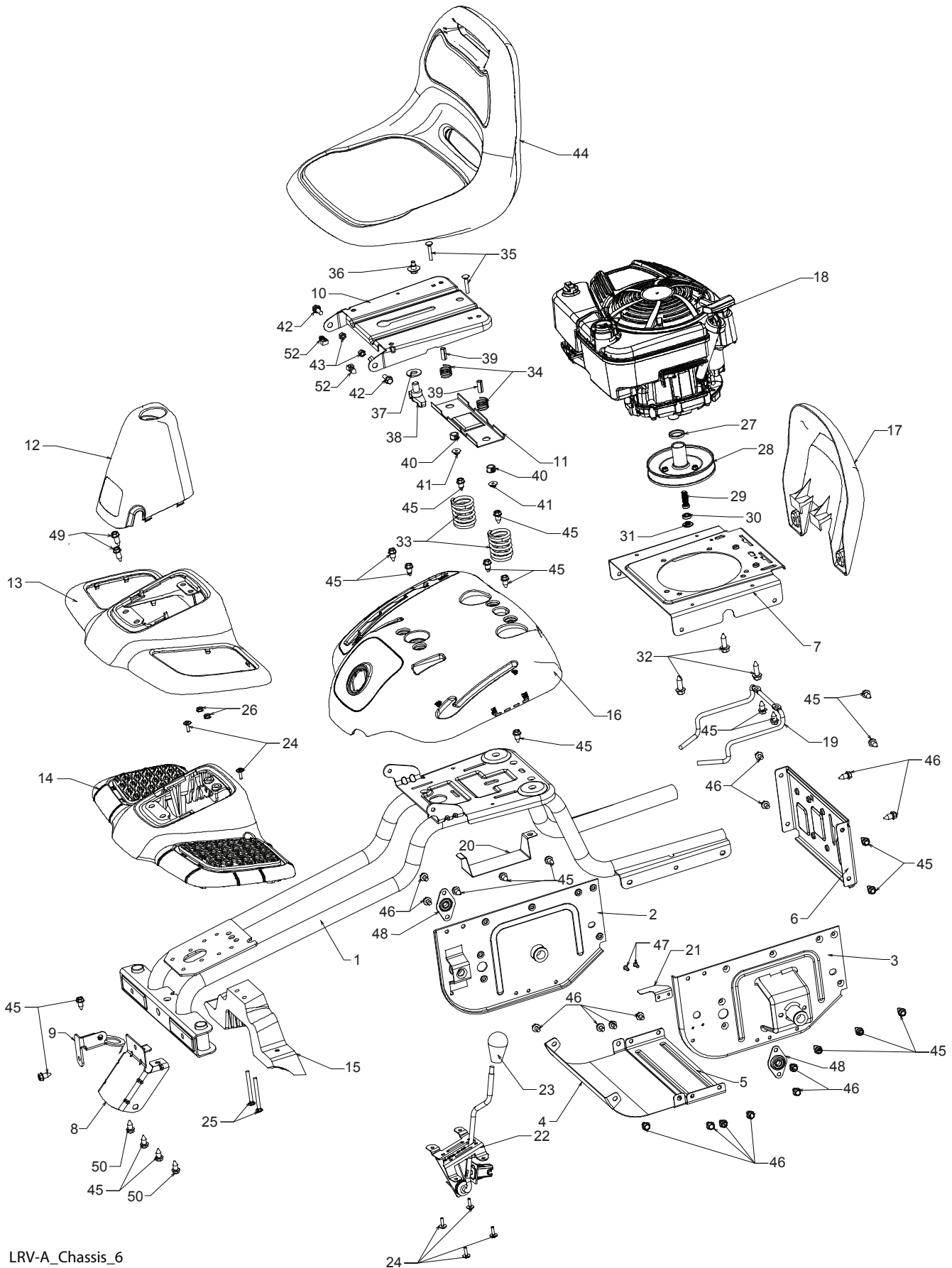

LRV-A_Chassis_6

RIDING MOWER - - MODEL NO. MOWCART 66 (96021000906)
CHASSIS AND ENCLOSURES 39

| KEY NO. | PART NO. | DESCRIPTION |
|---------|--------------|------------------------------------|
| 1 | 582 01 72-02 | WELDMENT, CHASSIS |
| 2 | 532 42 82-47 | SUPPORT, AXEL LH |
| 3 | 532 42 82-44 | SUPPORT, AXEL RH |
| 4 | 532 42 83-46 | SHIELD, TRANSAXLE FRONT |
| 5 | 532 42 81-10 | BRACE, AXLE CROSS |
| 6 | 532 42 81-09 | COVER, FRICTION DRIVE |
| 7 | 532 42 80-40 | PLATE, ENGINE |
| 8 | 532 42 85-76 | BRACKET, CHASSIS FRONT |
| 9 | 532 42 88-56 | BRACKET, STEERING SUPPORT |
| 10 | 532 19 55-30 | PAN, SEAT |
| 11 | 532 17 46-48 | BRACKET, SWITCH MOUNTING |
| 12 | 532 43 67-53 | BOOT, DUST |
| 13 | 532 43 69-13 | COVER, FOOT REST |
| 14 | 532 42 82-50 | STRUCTURE, FOOT REST |
| 15 | 532 42 82-49 | SUPPORT, FOOT REST |
| 16 | 532 43 69-11 | FENDER, CONTROL |
| 17 | 532 42 83-48 | GUARD, ENGINE |
| 18 | — — — — — | ENGINE, 121S07-0009-F1 (586329201) |
| 19 | 532 42 89-86 | KEEPER, BELT |
| 20 | 532 42 80-46 | BRACKET, BATTERY |
| 21 | 532 42 98-15 | LEVER, SWITCH |
| 22 | 532 42 88-26 | DECK CLUTCH ASM |
| 23 | 532 14 98-46 | KNOB |
| 24 | 532 41 63-58 | SCREW, NO. 10 |
| 25 | 872 14 04-24 | BOLT, CARRIAGE 1/4-20 X 3 |
| 26 | 873 51 04-00 | NUT, 1/4-20 |
| 27 | 532 43 00-87 | SPACER ENGINE |
| 28 | 580 74 72-01 | DISC, FRICTION ASM |
| 29 | 532 43 08-17 | BOLT, SCKT HD 3/8-24 X 1 .25 |
| 30 | 532 43 04-70 | BEARING |
| 31 | 532 43 73-22 | SPACER, NEUTRAL |
| 32 | 532 15 04-06 | BOLT, 3/8-16 X 1.280 |
| 33 | 532 12 41-81 | SPRING, SEAT |
| 34 | 532 12 12-50 | SPRING |
| 35 | 872 05 04-12 | BOLT, 1/4-20 X 1 1/2 |
| 36 | 532 12 70-18 | BOLT, SHOULDER |
| 37 | 819 17 19-12 | WASHER, 17/32 X 1 3/16 |
| 38 | 532 16 63-69 | KNOB, SEAT |
| 39 | 532 13 43-00 | SPACER |
| 40 | 532 12 12-48 | BUSHING, NYLON SNAP |
| 41 | 532 12 39-76 | NUT, LOCK |
| 42 | 532 17 18-52 | BOLT, 5/16-18 SHOULDER |
| 43 | 873 80 05-00 | NUT, 5/16-18 |
| 44 | 532 44 06-92 | SEAT |
| 45 | 817 00 05-12 | BOLT, 5/16-18 X 3/4 |
| 46 | 817 49 05-08 | BOLT, 5/16-18 X 1/2 |
| 47 | 532 08 67-77 | SCREW, |
| 48 | 532 40 89-81 | BEARING, FLANGE, BALL |
| 49 | 817 06 05-16 | SCREW, 5/16-18 X1 |
| 50 | 532 16 54-92 | BOLT, SHOULDER, 5/16-18 X .561 |
| 52 | 532 14 50-06 | CLIP PUSH-IN HINGED |

NOTE: All component dimensions given in U.S. inches
1 inch = 25.4 mm

RIDING MOWER - - MODEL NO. MOWCART 66 (96021000906)

DRIVE **40**

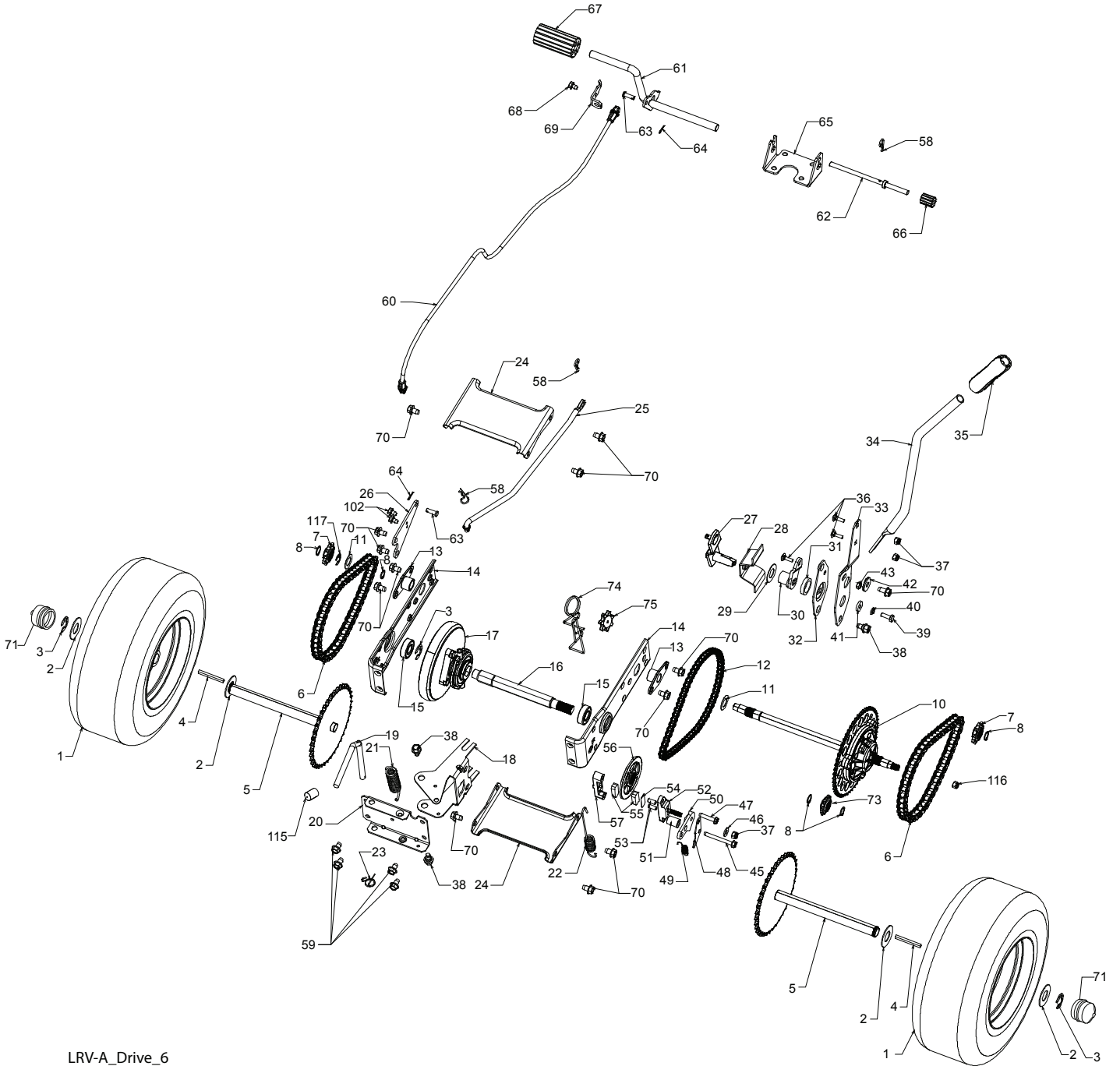

LRV-A_Drive_6

RIDING MOWER - - MODEL NO. MOWCART 66 (96021000906)

DRIVE 40

| KEY NO. | PART NO. | DESCRIPTION | KEY NO. | PART NO. | DESCRIPTION |
|------------|--------------|-------------------------------|------------|--------------|---------------------------|
| - | 532 43 61-44 | SERVICE KIT, TRANSAXLE | 42 | 532 16 60-02 | WASHER, SERRATED |
| 1 | 581 42 07-02 | WHEEL ASM (REAR) | 43 | 873 68 04-00 | NUT, CROWN LOCK 114-20 |
| 2 | 532 12 17-48 | WASHER, 16 GA. | 45 | 817 49 04-36 | SCREW 1/4-20 X 2 114 |
| 3 | 812 00 00-01 | E-CLIP | 46 | 819 09 10-16 | WASHER |
| 4 | 532 12 35-83 | KEY, SQUARE | 47 | 817 49 04-20 | SCREW, 1/4-20 X 1 1/2 |
| 5 | 532 42 79-39 | WELDMNT. DRIVE AXLE | 48 | 532 43 02-49 | PLATE BRAKE ANTI - ROTATE |
| 6 | 532 42 80-69 | CHAIN DRIVE | 49 | 532 43 02-45 | SPRING, BRAKE RETURN |
| 7 | 532 42 78-73 | SPROCKET, 9 TOOTH SPLINED | 50 | 532 42 80-21 | ARM, BRAKE |
| 8 | 812 10 00-09 | RING, SNAP | 51 | 532 43 02-47 | SPACER RETURN |
| 10 | 532 42 88-76 | DIFFERENTIAL ASM | 52 | 532 42 80-78 | CALIPER, BRAKE ASM |
| 11 | 532 00 13-70 | WASHER, THRUST | 53 | 877 01 08-10 | PIN, DOWEL 1/4 |
| 12 | 532 43 06-45 | CHAIN, PRIMARY DRIVE | 54 | 532 42 80-19 | PLATE, BRAKE PAD |
| 13 | 532 43 08-45 | BUSHING | 55 | 532 42 80-17 | PUCK BRAKE |
| 14 | 532 43 85-68 | BRACKET, CARRIER | 56 | 532 43 52-53 | ROTOR, BRAKE |
| 15 | 532 12 47-93 | BEARING ASM | 57 | 532 42 80-16 | CAP, BRAKE CALIPER |
| 16 | 532 42 79-26 | SHAFT INPUT | 58 | 532 12 47-88 | PIN, RETAINER |
| 17 | 532 43 72-81 | WHEEL, FRICTION ASM | 59 | 817 49 05-08 | BOLT, 5/16-16 X 112 |
| 18 | 532 42 47-59 | ARM, SHIFT | 60 | 532 44 08-55 | CABLE, BRAKE |
| 19 | 532 43 08-70 | ROD, BYPASS | 61 | 532 42 79-45 | WELDMNT, PEDAL |
| 20 | 532 42 79-97 | BRACE CARRIER REAR | 62 | 532 42 96-78 | ROD, PARKING BRAKE |
| 21 | 532 42 80-77 | SPRING, CARRIER | 63 | 877 10 08-12 | PIN, .25 X .75 CLEVIS |
| 22 | 532 42 80-76 | SPRING, BRAKE | 64 | 532 42 10-76 | PIN, COTTER 5/64 X 3/4 |
| 23 | 532 43 13-74 | SPRING, BYPASS | 65 | 532 42 93-25 | BRACKET, BRAKE SUPPORT |
| 24 | 532 42 79-95 | BRACE CARRIER BOX | 66 | 532 42 96-94 | COVER PEDAL |
| 25 | 532 42 83-03 | LINK, SHIFT | 67 | 532 42 96-93 | COVER, BRAKE PEDAL |
| 26 | 532 42 98-16 | ARM, CLUTCH | 68 | 817 49 04-06 | SCREW, 1/4-20 X 3/8 |
| 27 | 532 42 90-53 | WELDMNT SHIFT LEVER | 69 | 532 42 80-70 | BRAKE CABLE MOUNT |
| 28 | 532 42 83-02 | SUPPORT, SHIFT LEVER | 70 | 817 00 05-12 | BOLT, 5/16-18 X 3/4 |
| 29 | 532 17 48-40 | WASHER, NYLON | 71 | 532 19 32-68 | CAP HUB AXLE |
| 30 | 532 44 43-04 | HUB SHIFT LEVER | 73 | 532 42 95-19 | SPROCKET II TOOTH SPLINED |
| 31 | 532 42 90-55 | SPACER, NYLON | 74 | 532 43 78-41 | TENSION LRV CHAIN |
| 32 | 532 42 84-64 | MNTG BRKT. SHIFT ARM | 75 | 532 43 34-95 | SPROCKET IDLER 7 TOOTH |
| 33 | 532 42 84-61 | BRACKET, SHIFTER FLEX | 102 | 532 08 67-77 | THREAD CUTTER |
| 34 | 532 42 84-62 | TUBE SHIFT ARM | 115 | 532 14 00-62 | PLUNGER CAP |
| 35 | 580 96 23-01 | GRIP, HANDLE | 116 | 873 90 06-00 | NUT LOCK FLG. 3/8-16 UNC |
| 36 | 872 11 04-06 | BOLT, CARRIAGE - 114-20 X 3/4 | 117 | 812 00 00-40 | RING KLIP #T5304-62 |
| 37 | 873 80 04-00 | NUT NYLON LOCK 114-20 | | | |
| 38 | 532 16 54-92 | BOLT, SHOULDER | | | |
| 39 | 874 78 04-12 | BOLT, 1/4-20 X 3/4 | | | |
| 40 | 810 04 04-00 | WASHER, LOCK | | | |
| 41 | 819 09 12-10 | WASHER FLAT | | | |

NOTE: All component dimensions given in U.S. inches
1 inch = 25.4 mm

RIDING MOWER - - MODEL NO. MOWCART 66 (96021000906)
STEERING ASSEMBLY **41**

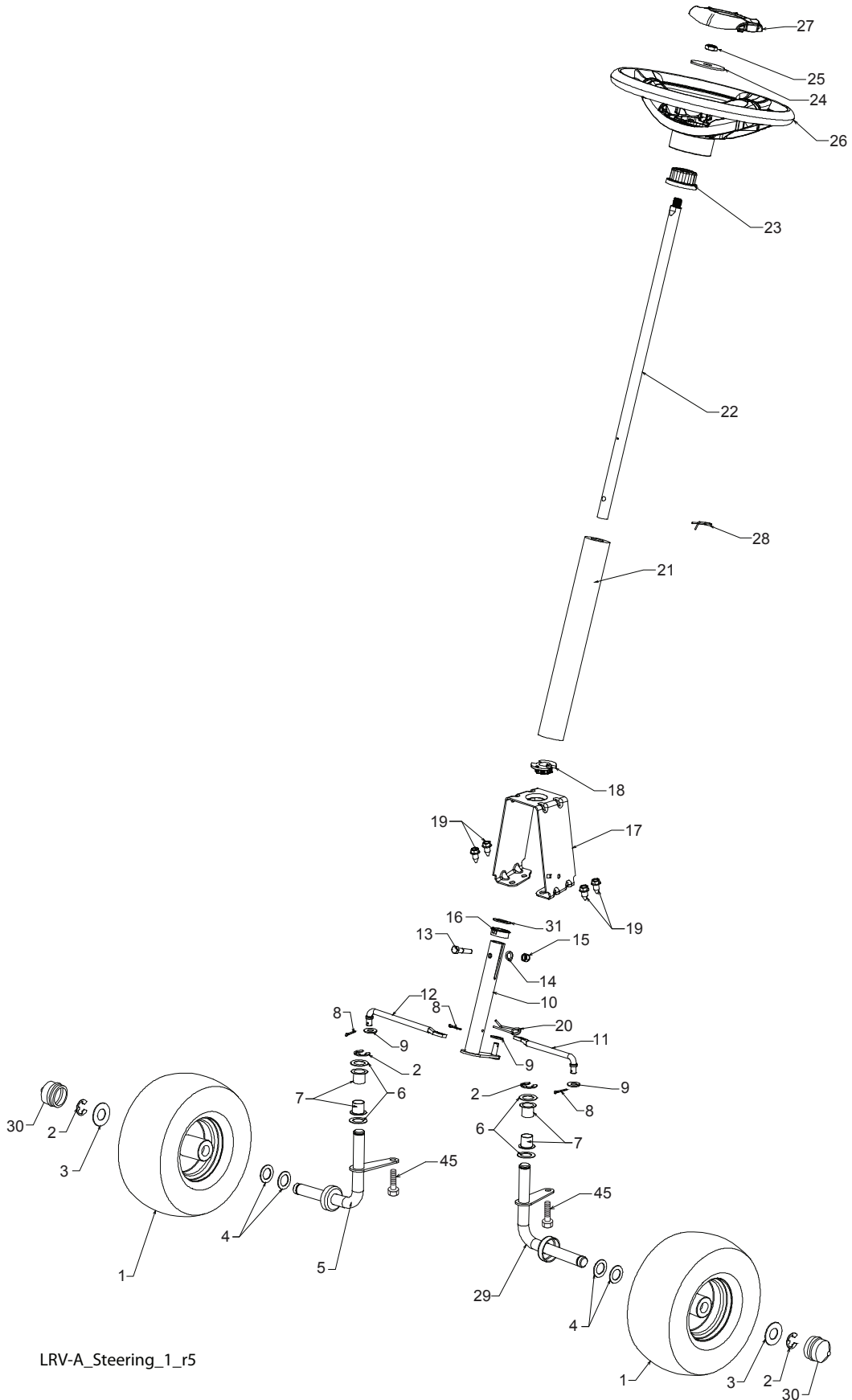

LRV-A_Steering_1_r5

RIDING MOWER - - MODEL NO. MOWCART 66 (96021000906)
STEERING ASSEMBLY 41

| KEY NO. | PART NO. | DESCRIPTION |
|---------|--------------|------------------------------|
| 1 | 581 42 06-02 | WHEEL ASM (FRONT) |
| 2 | 812 00 00-01 | E-CLIP |
| 3 | 532 18 89-67 | WASHER, HARDENED |
| 4 | 532 12 17-49 | WASHER, 1/4 X 3/4 |
| 5 | 532 43 53-24 | SPINDLE, RH |
| 6 | 532 12 49-31 | WASHER, HARDENED THRUST |
| 7 | 532 12 49-37 | BUSHING, STEERING COLUMN |
| 8 | 532 42 10-76 | PIN, 5/64 X 3/4 COTTER |
| 9 | 819 13 14-14 | WASHER |
| 10 | 532 42 80-38 | WELDMENT, LWR STRG SHAFT |
| 11 | 532 42 80-35 | LINK, STRNG LH |
| 12 | 532 42 80-36 | LINK, STRNG RH |
| 13 | 874 78 05-24 | BOLT, 5/16-18 X 1 1/2 |
| 14 | 819 13 10-16 | WASHER |
| 15 | 873 80 05-00 | NUT, 5/16-18 |
| 16 | 532 42 80-44 | BUSHING, STEERING SNAP |
| 17 | 532 42 82-52 | SUPPORT, UPPER STEERING |
| 18 | 532 19 52-27 | BUSHING, STEERING |
| 19 | 817 00 05-12 | BOLT, 5/16-18 X 3/4 |
| 20 | 532 42 80-45 | CLIP, RETAINER SPRING |
| 21 | 532 42 83-47 | COVER, STEERING COLUMN |
| 22 | 532 42 82-13 | SHAFT, STEERING |
| 23 | 532 43 77-47 | ADAPTER, STEERING WHEEL |
| 24 | 819 18 38-12 | WASHER, 9/16 X 2 3/8 12 GA. |
| 25 | 873 94 08-00 | NUT, JAM LOCK 1/2-20 |
| 26 | 532 42 45-51 | WHEEL, STEERING |
| 27 | 532 44 15-06 | CAP, STEERING WHEEL |
| 28 | 532 19 98-49 | CLIP, RETAINER SPRING |
| 29 | 532 43 53-23 | SPINDLE, LH |
| 30 | 532 19 32-68 | CAP, HUB, AXLE |
| 31 | 819 34 32-10 | WASHER |
| 45 | 532 16 54-92 | Bolt Shoulder 5/16-18 x .561 |

NOTE: All component dimensions given in U.S. inches
1 inch = 25.4 mm

RIDING MOWER - - MODEL NO. MOWCART 66 (96021000906)

MOWER DECK 44

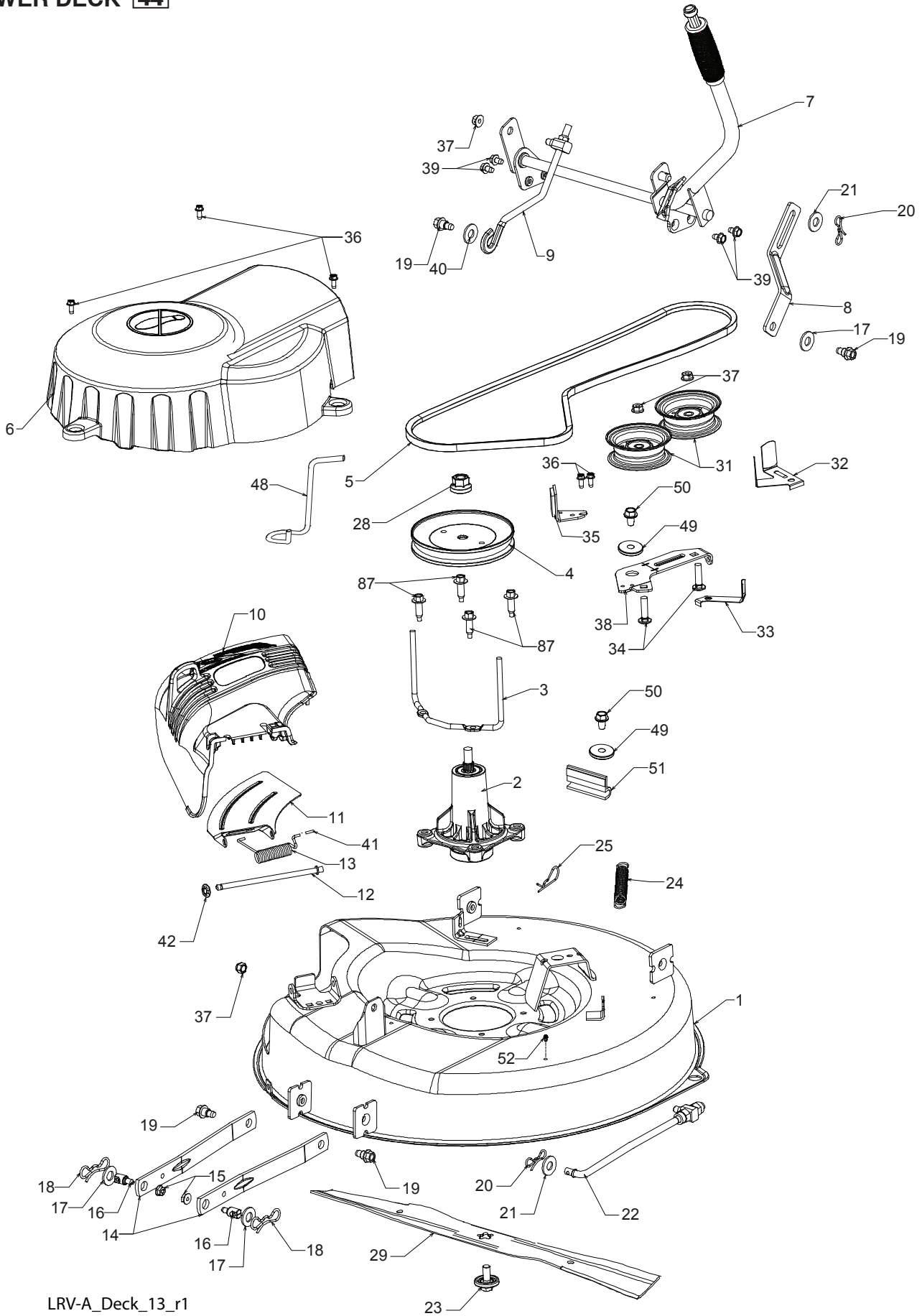

LRV-A_Deck_13_r1

RIDING MOWER - - MODEL NO. MOWCART 66 (96021000906)

MOWER DECK **44**

| KEY NO. | PART NO. | DESCRIPTION |
|---------|--------------|--------------------------------------|
| 1 | 532 42 81-93 | DECK, 26" |
| 2 | 587 25 33-01 | MANDREL ASM |
| 3 | 532 43 25-20 | KEEPER, BELT |
| 4 | 532 43 25-94 | PULLEY, MANDREL |
| 5 | 532 42 85-78 | BELT |
| 6 | 532 43 93-76 | COVER, MANDREL |
| 7 | 532 42 93-95 | LIFT ASM, DECK |
| 8 | 532 42 91-95 | LINK, DECK LIFT |
| 9 | 532 42 93-97 | LINK, ADJUSTABLE |
| 10 | 532 43 89-23 | DEFLECTOR |
| 11 | 532 42 89-68 | SUPPORT, DEFLECTOR |
| 12 | 532 13 14-91 | ROD, HINGE |
| 13 | 532 19 70-26 | SPRING, TORSION |
| 14 | 532 41 88-63 | ARM, MOWER SUPPORT |
| 15 | 873 90 05-00 | NUT, LOCK |
| 16 | 532 19 51-61 | STUD |
| 17 | 819 19 19-12 | WASHER |
| 18 | 532 19 42-09 | PIN |
| 19 | 532 19 65-39 | BOLT, SHOULDER |
| 20 | 532 19 42-08 | PIN |
| 21 | 819 17 19-12 | WASHER, 17/32 X 1 3/16 |
| 22 | 532 42 93-50 | LINK, DECK |
| 23 | 584 30 93-01 | SCREW |
| 24 | 532 42 95-31 | SPRING, DECK |
| 25 | 532 12 47-88 | PIN |
| 28 | 532 40 02-34 | NUT, LOCK |
| 29 | 532 43 90-52 | BLADE |
| 31 | 532 19 31-97 | PULLEY, |
| 32 | 532 14 10-43 | GUARD, IDLER |
| 33 | 532 19 34-14 | KEEPER, BELT IDLER |
| 34 | 872 11 06-12 | BOLT, 3/8-16 X 1 1/2 |
| 35 | 532 19 94-70 | ARM, BRAKE |
| 36 | 532 13 77-29 | SCREW, 1/4-20 X 5/8 |
| 37 | 873 90 06-00 | NUT, 3/8-16 FLANGE |
| 38 | 532 42 84-35 | ARM, IDLER |
| 39 | 817 49 05-08 | BOLT, 5/16-18 X 1/2 |
| 40 | 819 17 16-16 | WASHER, 16 GA. |
| 41 | 532 10 53-04 | CAP, SLEEVE |
| 42 | 532 11 04-52 | NUT, PUSH |
| 48 | 532 43 86-10 | KEEPER, BELT |
| 49 | 532 19 90-92 | SPACER RETAINER |
| 50 | 817 00 06-16 | SCREW 1/4-20 X 5/8 |
| 51 | 532 40 47-42 | BUMPER |
| 52 | 817 67 06-08 | SCREW THDROL 3/8-18 X 1/2 |
| 87 | 584 95 39-01 | Bolt, Hex Washer Head .313-18 x 1.19 |

NOTE: All component dimensions given in U.S. inches
1 inch = 25.4 mm

