

# ILLUSTRATED PARTS LIST

**MFG. ID NO. 96051006900**

**CUSTOMER CATALOG NO. M200-107TC**

**PRODUCT NO. 960 51 00-69**

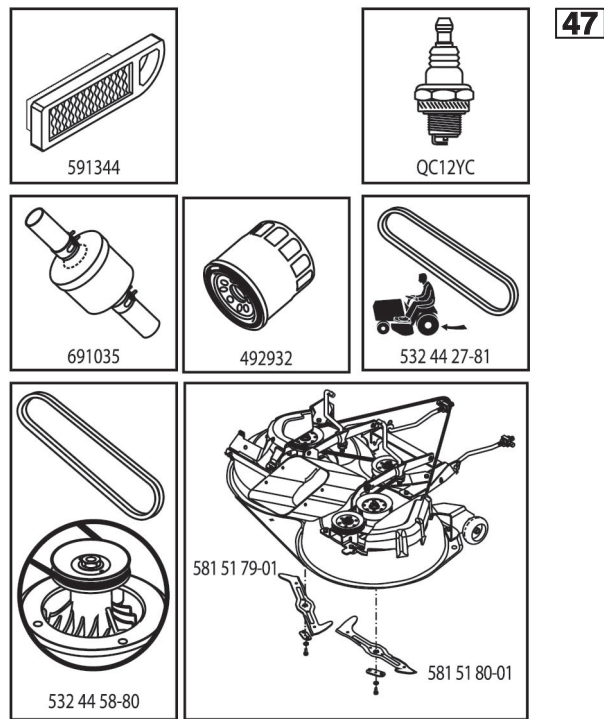

**TRACTOR - MODEL NO. M200-107TC (96051006900), PROD. NO. 960 51 00-69  
DECALS 27**

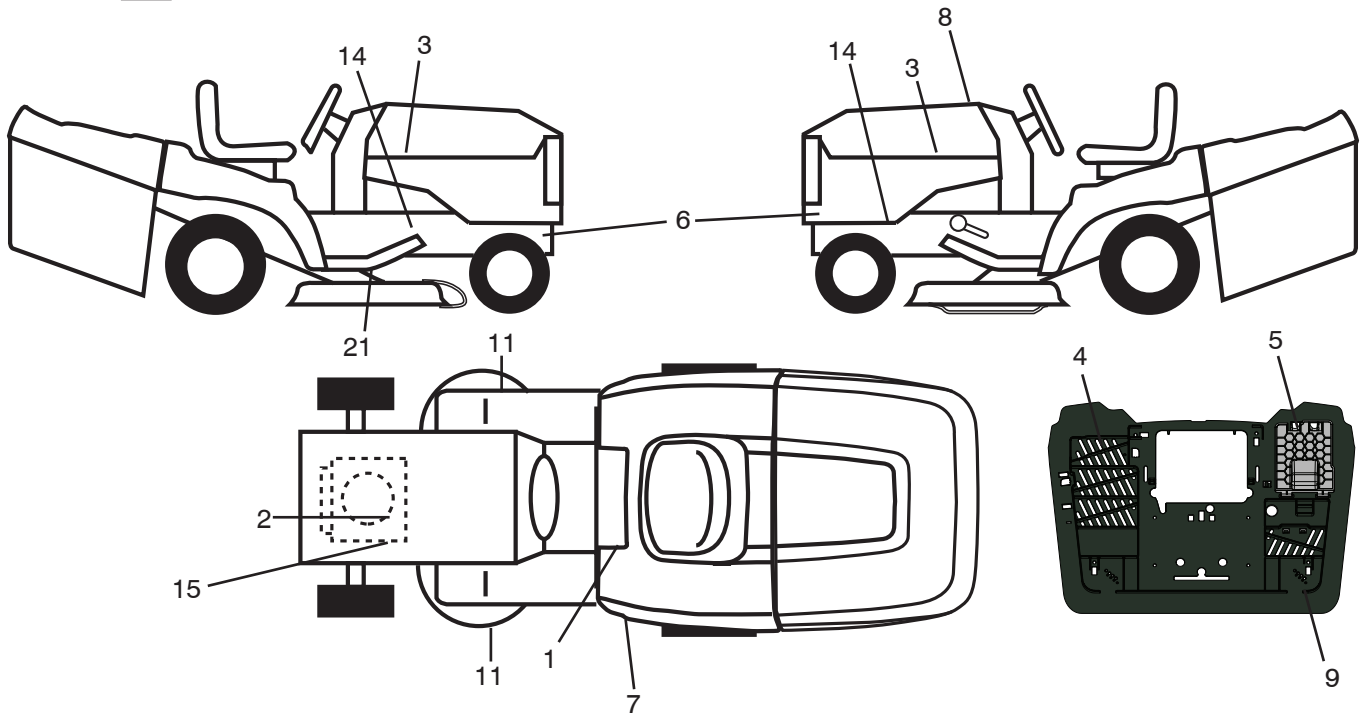

KEY NO.	PART NO.	DESCRIPTION
1	581 57 83-01	Decal, Warning
2	581 57 97-01	Decal, Warning Eng. Sym.
3	581 09 12-01	Decal, Hood RH/LH
4	532 44 54-93	Decal, Warning
5	532 44 51-02	Decal, Battery Door
6	581 57 98-01	Decal, Warning
7	581 96 50-01	Decal, SDFNDR
8	584 23 40-01	Decal, Replacement
9	532 44 46-19	Decal, Bypass
11	581 57 91-01	Decal, Cut Finger

KEY NO.	PART NO.	DESCRIPTION
14	581 57 96-01	Decal, Chassis Hot Muffler
15	581 25 90-01	Decal, Engine HP
21	532 44 11-89	Decal, Belt Sch CRD
--	532 42 59-86	Pad Footrest RH
--	532 42 59-76	Pad Footrest LH
--	587 24 13-40	Manual Operator's (Euro)
--	587 24 13-50	Manual Operator's (Scan)
--	587 24 13-20	Manual Operator's (E-Bloc)
--	587 24 13-30	Manual Operator's (Baltic)

**WHEELS & TIRES**

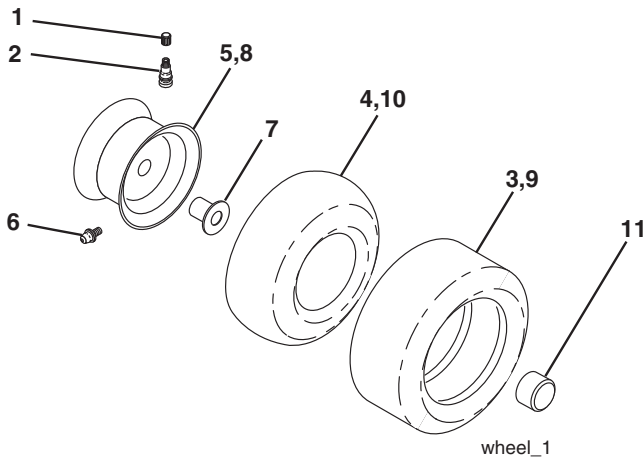

KEY NO.	PART NO.	DESCRIPTION
1	532 05 91-92	Cap Valve Tire
2	532 06 51-39	Stem Valve
3	532 10 62-22	Tire Front 15 x 6-6
4	532 05 99-04	Tube Inner Front #35060
5	532 12 51-21	Rim Asm 6" Front Service
6	532 12 49-57	Fitting Grease
7	532 12 49-59	Bearing Flange
8	532 12 51-22	Rim Asm 8" Rear Service
9	532 42 05-31	Tire Rear 18 x 9.5-8
10	532 12 49-26	Tube Rear 9 5 x 8 Service
11	532 19 32-68	Cap Axle
--	532 14 43-34	Sealant, Tire (10 oz. Tube)

**NOTE:** All component dimensions given in U.S. inches  
1 inch = 25.4 mm

# TRACTOR - MODEL NO. M200-107TC (96051006900), PROD. NO. 960 51 00-69

## SCHEMATIC **38**

SCH17

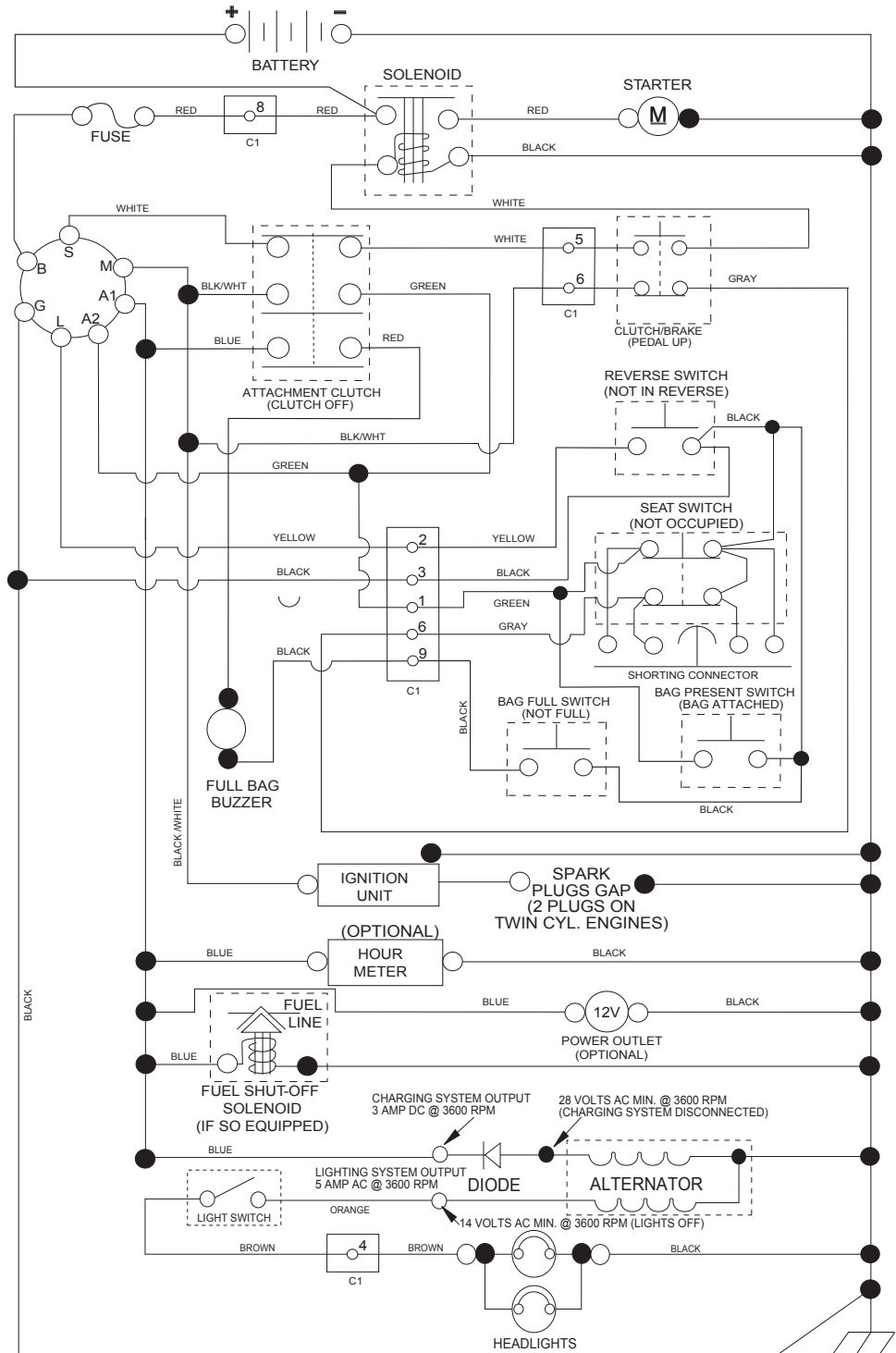

**NOTE**  
YOUR TRACTOR IS EQUIPPED WITH A SPECIAL ALTERNATOR SYSTEM. THE LIGHTS ARE NOT CONNECTED TO THE BATTERY, BUT HAVE THEIR OWN ELECTRICAL SOURCE. BECAUSE OF THIS, THE BRIGHTNESS OF THE LIGHTS WILL CHANGE WITH ENGINE SPEED. AT IDLE THE LIGHTS WILL DIM. AS THE ENGINE SPEED IS INCREASED, THE LIGHTS WILL BECOME THEIR BRIGHTEST.

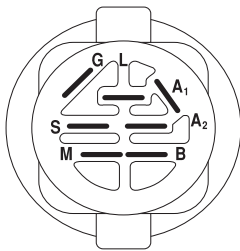

IGNITION SWITCH

POSITION	CIRCUIT	"MAKE"
OFF	M+G+A1	
RUN/OVERRIDE	B+A1	
RUN	B+A1	L+A2
START	B + S + A1	

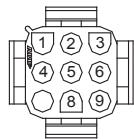

CHASSIS HARNESS CONNECTOR (C1) (MATING SIDE)

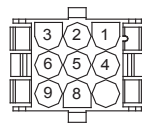

DASH HARNESS CONNECTOR (C1) (MATING SIDE)

WIRING INSULATED CLIPS  
NOTE: IF WIRING INSULATED CLIPS WERE REMOVED FOR SERVICING OF UNIT, THEY SHOULD BE RE-INSTALLED TO PROPERLY SECURE YOUR WIRING.

NON-REMOVABLE CONNECTIONS  
REMOVABLE CONNECTIONS

**TRACTOR - MODEL NO. M200-107TC (96051006900), PROD. NO. 960 51 00-69**  
**ELECTRICAL 32**

TC03S

With Service Minder Option

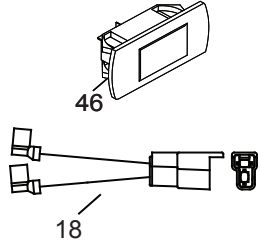

With Charge Indicator Option

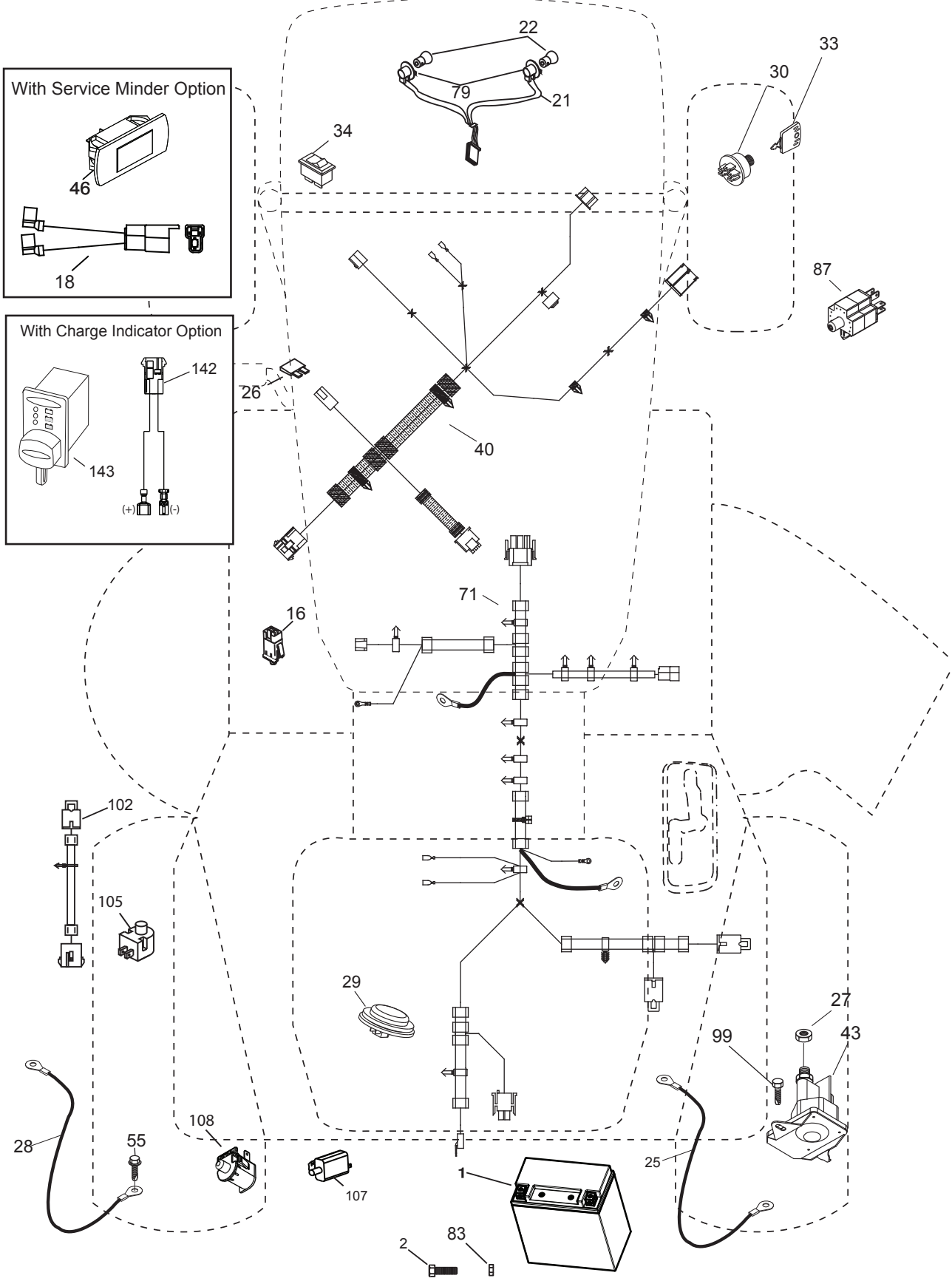
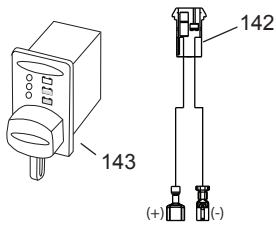

**TRACTOR - MODEL NO. M200-107TC (96051006900), PROD. NO. 960 51 00-69  
ELECTRICAL 32**

<b>KEY NO.</b>	<b>PART NO.</b>	<b>DESCRIPTION</b>
1	532 43 71-57	Battery
2	532 44 09-23	Screw Hex Hd Cap M6 x 1.12mm
16	532 17 61-38	Switch Interlock
21	532 40 02-52	Harness Asm Light w/4152J
22	532 00 41-52	Bulb Light #1156
25	532 44 13-82	Cable Battery Red
26	532 17 51-58	Fuse
27	873 51 04-00	Nut Keps Hex 1/4-20 unc
28	532 44 13-83	Cable Ground Black
29	532 40 15-45	Switch Seat
30	532 19 33-50	Switch Ignition
33	532 41 19-35	Key/Chain
34	532 11 07-12	Switch Light
40	532 42 10-02	Harness Ignition Dash
41	817 72 04-08	Screw 1/4-20 x 1/2
43	532 19 25-07	Solenoid
55	817 06 05-12	Screw 5/16-18 x 3/4
71	532 44 08-20	Harness Chassis
79	532 17 52-42	Socket Asm.
83	532 43 67-74	Nut Square M6 x 1 x 8.5 x 11mm
87	532 42 10-60	Switch Railmount
102	532 44 12-62	Harness Pigtail
105	532 40 75-68	Switch Reverse
107	532 18 03-79	Switch Full Bagger Indicator
108	532 42 10-62	Switch Snapmount

**NOTE:** All component dimensions given in U.S. inches  
1 inch = 25.4 mm

TRACTOR - MODEL NO. M200-107TC (96051006900), PROD. NO. 960 51 00-69  
CHASSIS AND ENCLOSURES **39**

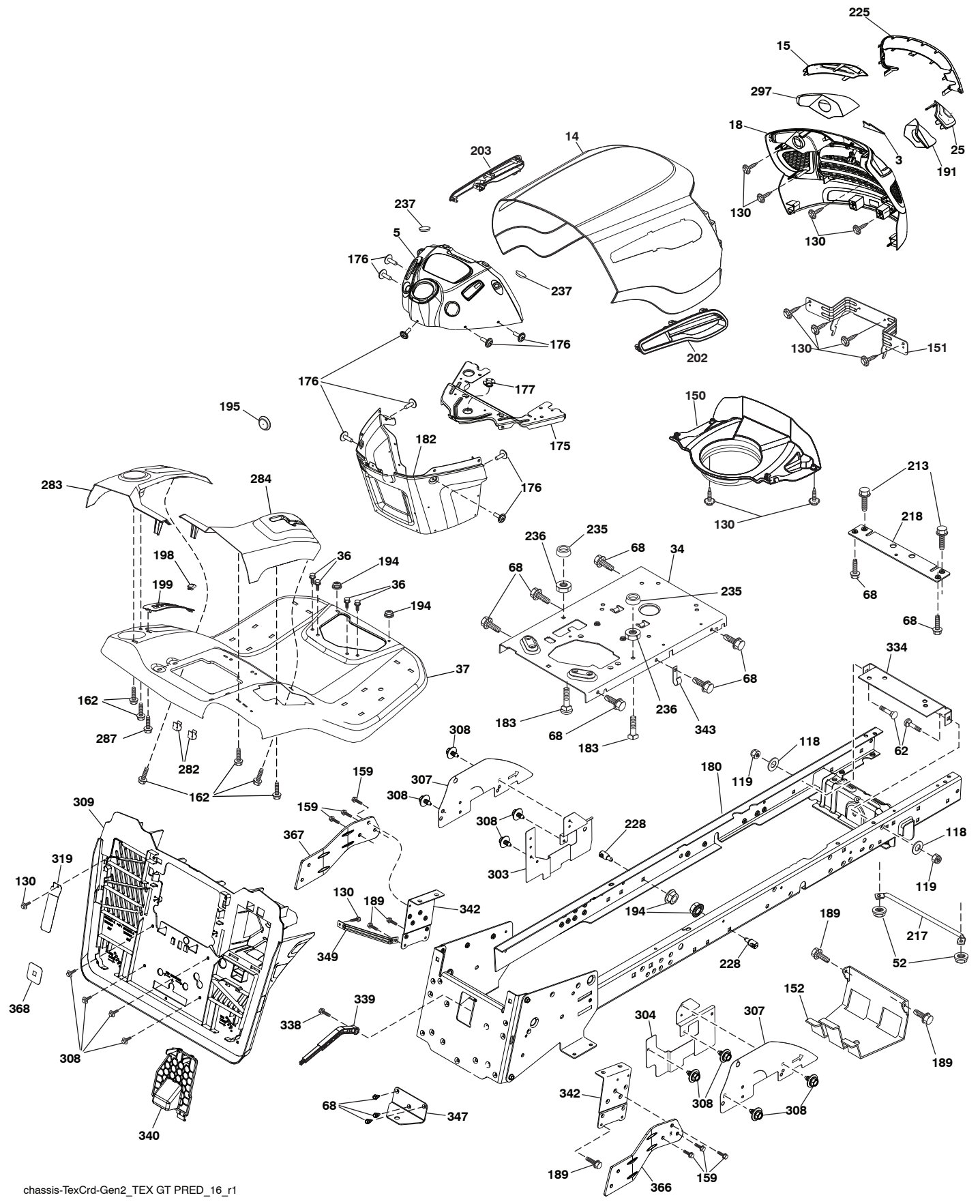

**TRACTOR - MODEL NO. M200-107TC (96051006900), PROD. NO. 960 51 00-69  
CHASSIS AND ENCLOSURES 39**

KEY NO.	PART NO.	DESCRIPTION	KEY NO.	PART NO.	DESCRIPTION
3	578 89 71-01	Emblem Mount	217	532 40 91-67	Rod Pivot Hood
5	532 44 18-82	Dash	218	532 19 63-95	X-Piece Hood Stop
14	532 44 80-42	Hood	225	581 10 32-01	Trim Ring
15	581 10 31-01	Lens LH	228	532 19 51-61	Stud Fastener
18	581 10 29-01	Grille	235	532 40 61-29	Spacer Fender
25	581 10 30-01	Lens RH	236	873 93 05-00	Nut Lock 5/16-18 unc
34	580 91 09-01	Plate Engine	237	532 40 37-04	Plug Mount Cargo
36	817 06 05-12	Screw 5/16-18 x 3/4	282	532 41 41-10	Clip Retainer
37	532 44 08-49	Fender	283	532 44 76-71	Console Deck Lift
52	873 68 05-00	Nut Crown Lock 5/16	284	532 44 72-11	Console Shift RH
62	872 11 06-08	Bolt 3/8-16 x 1 Gr. 5	287	817 60 04-06	Screw Hex Washhead 1/4-20 x 3/8
68	817 49 05-08	Screw Thdrol. 5/16-18 x 1/2	297	581 22 36-01	Insert Reflective LH
118	819 13 13-16	Washer 13/32 x 13/16 x 16 Ga.	303	587 49 31-02	Shield, Chassis French LH
119	873 68 06-00	Nut 3/8-16 unc	304	587 49 27-02	Shield, Chassis French RH
130	532 41 63-58	Screw #10 x 0.750 BOS Thread	307	587 49 45-01	Shield, Chassis Upper
150	584 86 29-01	Duct, Air	308	532 17 18-77	Bolt 5/16-18 unc x 3/4
151	532 44 54-94	Bracket Pivot Hood	309	581 32 89-11	Backplate Bagger
152	532 19 95-35	Shield Browning	319	581 31 39-06	Lever Bagger
159	817 00 06-12	Screw Hexwsh Thdr 3/8-16 x 3/4	334	532 44 25-37	Engine Plate
162	532 14 24-32	Screw HexWsh. Hi-Lo 1/4 x 1/2 unc	338	532 43 66-40	Bolt Shoulder
175	532 19 63-04	Crossmember	339	532 43 66-41	Lever Bagger Full
176	532 40 07-76	Screw 10-24 x 5/8	340	581 32 90-01	Door Battery
177	532 19 52-27	Bushing Steering	342	532 43 59-38	Support Fender
180	583 90 27-01	Chassis	343	532 44 07-49	Clip
182	586 73 86-02	Dash Lower	347	532 44 58-32	Hitch
183	874 52 05-20	Bolt 5/16-18 x 1-1/4	349	532 43 66-06	Bracket, Support
189	817 00 05-12	Screw 5/16-18 x 3/4	366	581 31 46-02	Bracket RH Front Bagger
191	581 22 35-01	Insert Reflective RH	367	581 31 45-02	Bracket LH Front Bagger
194	873 90 05-00	Nut Lock Hex Flange 5/16-18	368	581 42 48-01	Full Lever Bagger
195	532 40 41-37	Plug 12V Adapter	--	532 44 11-26	Plug Dash
198	532 44 80-48	Indicator Deck Lift	--	532 40 09-44	Bumper
199	532 41 87-39	Plate Deck Lift			
202	581 85 91-01	Vent Hood RH			
203	581 85 92-01	Vent Hood LH			
213	874 76 05-12	Bolt 5/16-18 x 3/4			

**NOTE:** All component dimensions given in U.S. inches  
1 inch = 25.4 mm



**TRACTOR - MODEL NO. M200-107TC (96051006900), PROD. NO. 960 51 00-69**  
**DRIVE 40**

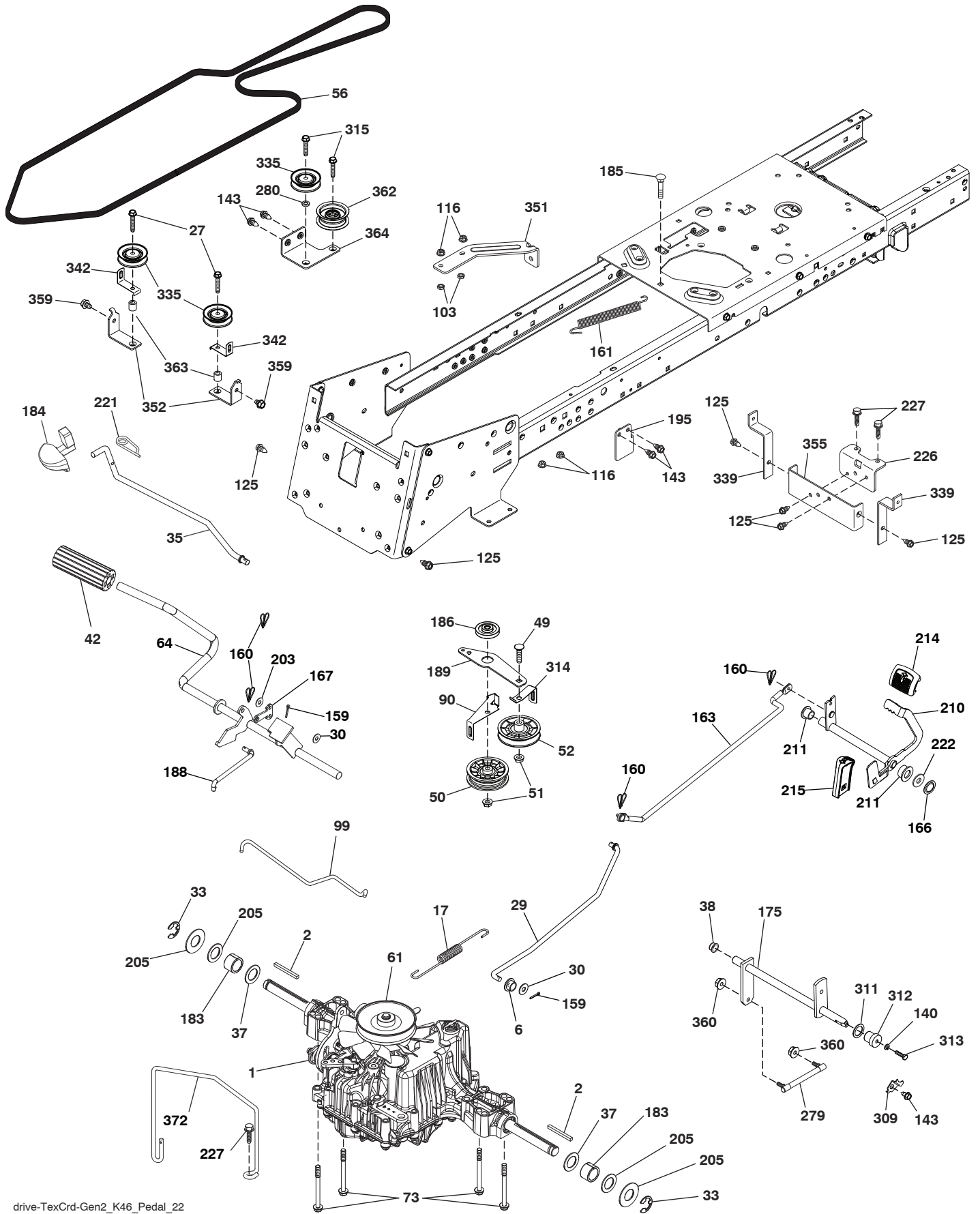



**TRACTOR - MODEL NO. M200-107TC (96051006900), PROD. NO. 960 51 00-69  
DRIVE 40**

KEY NO.	PART NO.	DESCRIPTION	KEY NO.	PART NO.	DESCRIPTION
1	---	Transaxle, TUFFTORQ K46 DF (446488) (Order parts from trans-axle manufacturer.)	186	532 19 43-21	Spacer Retainer
2	532 12 35-83	Key Square	188	532 19 43-23	Link Clutch Ground Drive
6	532 12 40-28	Bushing Snap	189	532 43 36-11	Bellcrank Ground Drive
17	532 43 62-27	Spring, Brake	195	580 45 69-01	Bracket Brake Rod
27	817 49 05-28	Screw Hexwsh Thd. 5/16-18 x 1-3/4	203	819 11 11-16	Washer 11/32 x 11/16 x 16 Ga.
29	532 44 27-95	Rod, Brake	205	532 12 17-48	Washer 25/32 x 1-5/8 16 Ga.
30	819 13 16-16	Washer 13/32 x 1 x 16 Ga.	210	532 40 09-80	Rocker Asm. Pedal
33	812 00 00-01	Ring E	214	532 42 12-63	Pedal Forward
35	583 86 45-01	Rod, Brake, Park	215	532 41 94-82	Pad Pedal Reverse
37	532 18 89-67	Washer .793 x 1.637 x 060	211	532 12 01-83	Bearing Nylon
38	532 16 96-13	Nylon Snap In	221	532 40 31-87	Retainer Spring
42	532 12 48-72	Cover, Foot Pedal	222	879 21 20-10	Washer Flat
49	872 11 06-14	Bolt 3/8-16 unc	226	532 40 15-64	Bracket Mount Torque
50	532 19 43-27	Idler Flat	227	817 49 05-12	Screw
51	873 90 06-00	Lock Nut 3/8-16	279	532 44 42-83	Link Shift Hydro
52	532 19 43-26	Idler V-Groove	280	819 11 10-12	Washer 11/32 x 5/8 x 12 Ga.
56	532 44 27-81	V-Belt, Drive	309	532 16 55-81	Plate Fstnr.
61	532 44 51-51	Pulley Transaxle	311	532 16 98-45	Washer Nylon
64	532 19 78-65	Shaft Asm. Pedal Brake Control	312	532 16 56-14	Hub Tapered
73	874 49 05-44	Bolt Hex 5/16-18 Gr. 5	313	874 78 04-16	Bolt Hex Fin 1/4-20 unc x 1. Gr 5
90	532 44 36-05	Keeper Belt Clutching	314	532 44 47-13	Retainer, Belt
99	532 44 39-47	Rod Bypass	315	817 58 05-20	Screw Thdrol 5/16-18 x 4.25
103	873 35 05-00	Nut 5/16-18 unc	335	532 19 95-34	Pulley V Idler Ground Drive
116	873 90 05-00	Nut Lock Hex Flange 5/16-18	339	532 43 68-67	Strap Torue K46 CRD Tex
125	817 00 05-12	Screw 5/16-18 x 3/4	342	532 18 26-82	Keeper Belt
140	810 04 04-00	Washer Lock Hvy. Helical 1/4	351	532 43 69-98	Bracket Deck Sway
143	817 49 05-08	Screw Thdrol 5/16-18 x 1/2 TYTT	352	532 43 56-45	Bracket Idler
159	876 02 04-12	Pin Cotter 1/8 x 3/4	355	532 43 56-69	Strap Torque
160	532 16 94-84	Retainer Clip	359	817 49 06-10	Screw Thdrol 3/8-16 x 5/8
161	532 10 57-09	Spring, Return, Clutch	360	532 44 47-14	Nut Hex 5/16-24
163	532 44 27-93	Rod Control	362	532 43 68-12	Idler Flat
166	532 42 91-64	Nut Push .625	363	532 44 27-80	Spacer 343 x 63 x .62
167	532 40 52-57	Latch Brake Parking	364	532 44 30-32	Bracket Idler
175	532 42 93-59	Shaft Asm. Cross Shift	372	587 06 27-01	Keeper Belt Transaxle
183	532 13 70-57	Spacer Axle			
184	587 65 37-01	Handle Park Brk.			
185	872 11 06-22	Bolt 3/8-16 unc x 2-3/4			

**NOTE:** All component dimensions given in U.S. inches  
1 inch = 25.4 mm

TRACTOR - MODEL NO. M200-107TC (96051006900), PROD. NO. 960 51 00-69  
ENGINE **24**

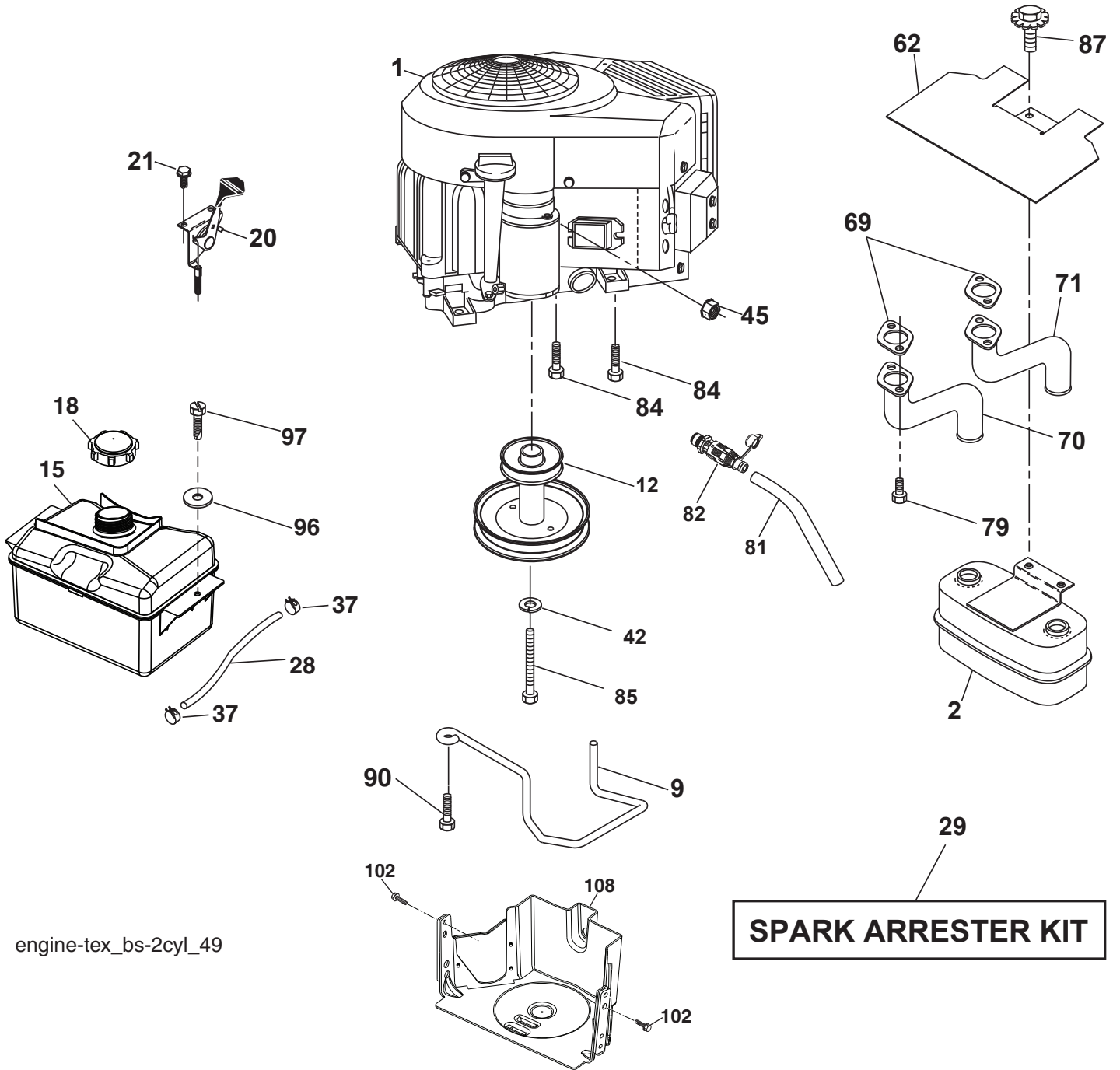

engine-tex\_bs-2cyl\_49

**TRACTOR - MODEL NO. M200-107TC (96051006900), PROD. NO. 960 51 00-69  
ENGINE 24**

KEY NO.	PART NO.	DESCRIPTION
1	— — — — —	Engine Briggs Model 40R877-0004-B1 (585700501) (Order parts from engine manufacturer)
2	532 14 97-23	Muffler
9	584 90 80-01	Keeper Belt Engine
12	532 40 54-71	Pulley Engine
15	532 43 08-25	Tank Fuel
18	532 43 02-20	Cap Fuel
20	532 42 35-02	Control Throttle/Choke
21	532 41 63-58	Screw #10 x 0.750
28	532 13 70-40	Line Fuel
29	532 13 71-80	Kit Spark Arrester (Flat Scrn)
37	532 12 34-87	Clamp Hose Blk
42	810 04 07-00	Washer Lock 7/16
45	873 51-04-00	Nut Keps Hex 1/4-20 unc
62	532 43 40-17	Shield Heat Muffler
69	532 16 53-91	Gasket Muffler
70	581 88 11-01	Exhaust Tube LH
71	581 88 10-01	Exhaust Tube RH
79	532 18 39-06	Screw
81	532 14 84-56	Tube Drain
82	532 42 82-87	Valve Oil Drain
84	817 06 06-20	Screw 3/8-16 x 1-1/4
85	532 17 39-37	Bolt 7/16-20 x 4 x Gr. 5-1.5 THR
87	532 17 18-77	Bolt 5/16-18 unc x 3/4
90	817 00 06-16	Screw 3/8-16 x 1
96	819 09 14-16	Washer 9/32 x 7/8 x 16 Ga.
97	817 67 04-12	Screw Hexwsh Thdrol 1/4-20 x 3/4
102	817 06 05-16	Screw 5/16-18 x 1
108	532 42 30-41	Cover Pulley Engine

**NOTE:** All component dimensions given in U.S. inches  
1 inch = 25.4 mm

**Engine Power Rating Information**

The gross power rating for individual gas engine models is labeled in accordance with SAE (Society of Automotive Engineers) code J1940 (Small Engine Power & Torque Rating Procedure), and rating performance has been obtained and corrected in accordance with SAE J1995 (Revision 2002-05). Torque values are derived at 3060 RPM; horsepower values are derived at 3600 RPM. Actual gross engine power will be lower and is affected by, among other things, ambient operating conditions and engine-to-engine variability. Given both the wide array of products on which engines are placed and the variety of environmental issues applicable to operating the equipment, the gas engine will not develop the rated gross power when used in a given piece of power equipment (actual “on-site” or net power). This difference is due to a variety of factors including, but not limited to, accessories (air cleaner, exhaust, charging, cooling, carburetor, fuel pump, etc.), application limitations, ambient operating conditions (temperature, humidity, altitude), and engine-to-engine variability. Due to manufacturing and capacity limitations, Briggs & Stratton may substitute an engine of higher rated power for this Series engine.

**TRACTOR - MODEL NO. M200-107TC (96051006900), PROD. NO. 960 51 00-69**  
**STEERING ASSEMBLY [41]**

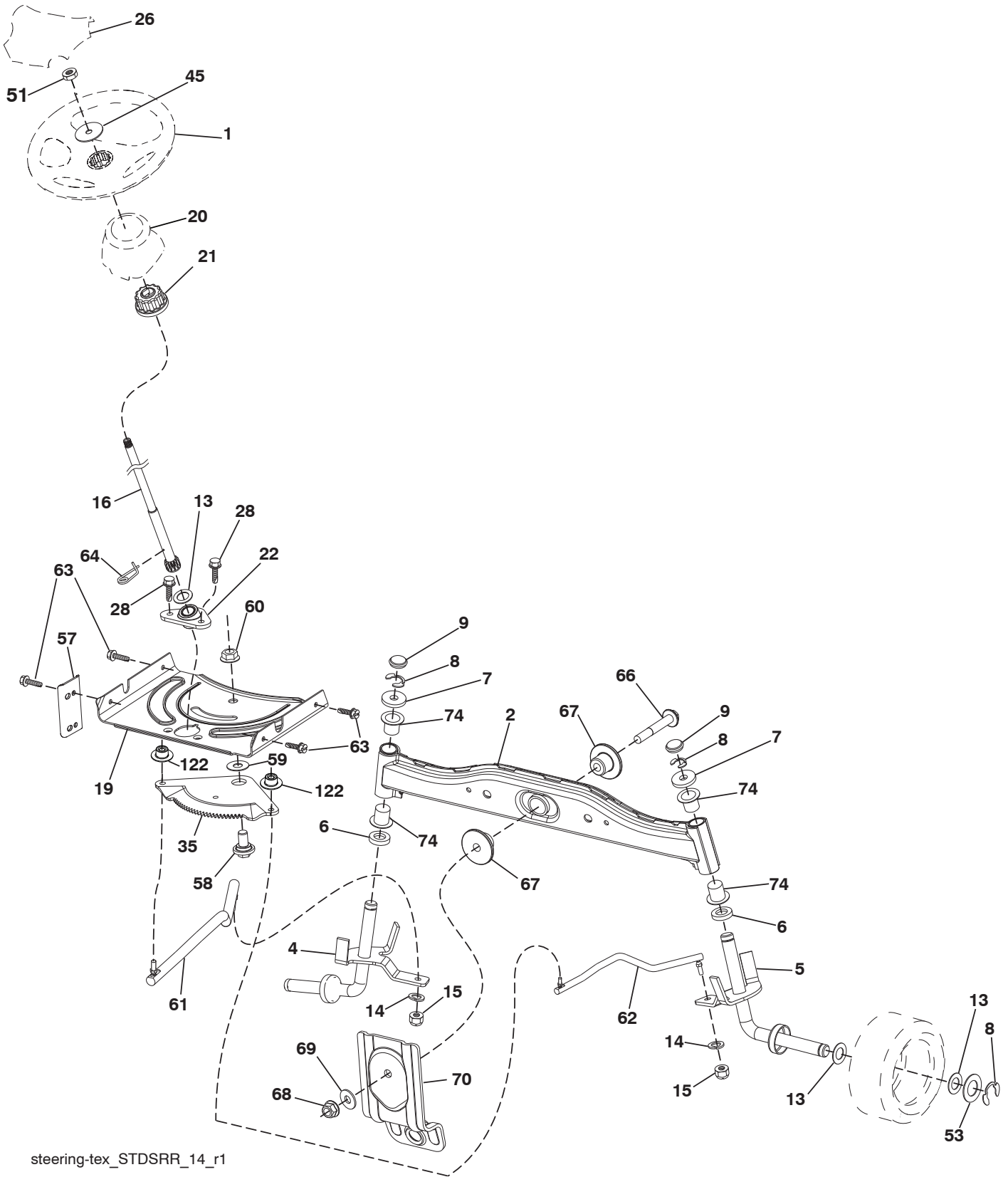

steering-tex\_STDSRR\_14\_r1

**TRACTOR - MODEL NO. M200-107TC (96051006900), PROD. NO. 960 51 00-69**  
**STEERING ASSEMBLY 41**

<b>KEY NO.</b>	<b>PART NO.</b>	<b>DESCRIPTION</b>
1	532 44 28-04	Wheel, Steering
2	532 41 81-68	Axle Asm., Front
4	532 40 30-87	Spindle Asm., LH
5	532 40 30-88	Spindle Asm., RH
6	532 12 49-31	Bearing, Race Thrust Harden
7	532 12 17-48	Washer 25/32 x 1-5/8 x 16 Ga.
8	812 00 00-29	Ring, Klip #T5304-75
9	532 12 12-32	Cap, Spindle
13	532 12 17-49	Washer 25/32 x 1-1/4 x 16 Ga.
14	810 04 06-00	Washer, Lock Hvy Hlcl Spr 3/8
15	873 54 06-00	Nut, Crown Lock 3/8-24 unf
16	532 19 47-46	Shaft Steering
19	532 19 47-29	Plate Steering
20	532 42 47-40	Boot, Steering
21	532 18 67-37	Adapter, Wheel Steering
22	532 42 05-37	Strg. Supt. Lower
26	532 44 77-59	Insert, Wheel Steering
28	817 00 06-12	Screw 3/8-16 x 3/4
35	532 19 47-32	Gear, Sector Plate
45	819 18 38-12	Washer 9/16ID x 2-3/8OD.12
51	873 94 08-00	Nut Hex Jam
53	532 18 89-67	Washer Hardened .793 x 1.637 x .060
57	532 40 74-65	Bracket Upstop
58	532 19 47-47	Bolt Shoulder Sector Pivot CFM
59	532 19 47-48	Washer Thrust Sector Steering
60	873 97 10-00	Nut Flange Lock 5/8-11
61	532 19 47-40	Draglink, LH
62	532 19 47-41	Draglink, RH
63	817 00 05-12	Screw 5/16-18 x 3/4
64	532 19 98-49	Retainer Clip Spring Steering
66	871 02 07-48	Bolt Hex Fghd 7/16-14 x 3 Serr
67	532 19 47-37	Bushing PM Front Axle
68	873 90 07-00	Nut Lock Flange 7/16-14 Gr. 5
69	532 19 91-62	Washer 1.5 x .505 x .118
70	585 33 88-01	Bracket Deck Susp. Front
74	532 12 49-37	Bearing
122	532 44 49-62	Cap Gear Sector

**NOTE:** All component dimensions given in U.S. inches  
1 inch = 25.4 mm

**TRACTOR - MODEL NO. M200-107TC (96051006900), PROD. NO. 960 51 00-69**  
**MOWER DECK 44**

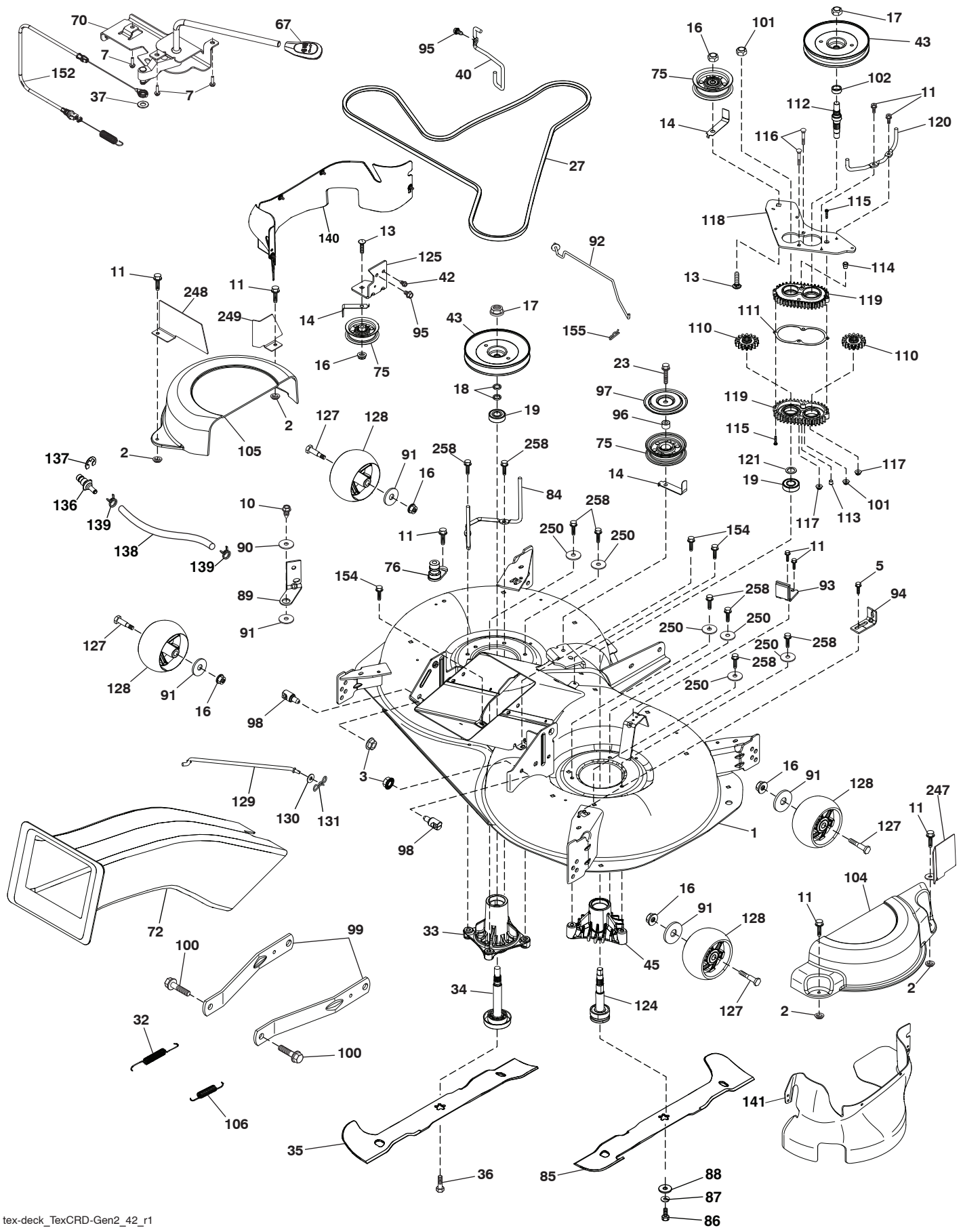



**TRACTOR - MODEL NO. M200-107TC (96051006900), PROD. NO. 960 51 00-69**  
**MOWER DECK 44**

KEY NO.	PART NO.	DESCRIPTION	KEY NO.	PART NO.	DESCRIPTION
1	532 44 77-36	Deck Weldment	111	532 43 69-79	Gasket Gearcase
2	532 42 30-62	Pal Nut	112	532 44 38-52	Shaft Gearcase Adapter
3	873 90 05-00	Nut Lock Hex Flange 5/16 - 18	113	532 43 85-33	Plug Oil
5	817 00 05-10	Bolt 5/16-18	114	532 43 85-34	Valve Relief
7	532 41 63-58	Screw #10 x 0.750 BOS Thread	115	818 03 10-16	Screw Torx #10-24 x 1
10	817 00 06-16	Screw 3/8-16x1 smgml tap	116	872 11 04-14	Bolt 1/4-20 x 1.75 Gr. 5
11	532 13 77-29	Screw Thd Roll 1/4 - 20 X 5/8	117	873 90 04-00	Nut Hex Flange 1/4-20 unc
13	872 11 06-12	Bolt Carr Sh 3/8 - 16 X 1-1/2 Gr. 5	118	532 44 32-32	Arm Clutching
14	532 15 60-85	Keeper Belt Idler	119	532 43 81-66	Gearcase Subasm
16	873 90 06-00	Nut Lock FIG 3/8 - 16 unc	120	532 44 32-36	Keeper Belt RH
17	532 40 02-34	Nut Flange Lock Top	121	532 43 69-85	Washer
18	532 18 76-90	Washer Spacer Mandrel	124	581 65 07-01	Non Greasable Mandrel Shaft
19	532 11 04-85	Bearing Ball Mandrel	125	532 44 04-20	Bracket Idler Chassis
23	817 49 06-28	Screw Thdrol 3/8 - 16 X 1-3/4	127	532 19 34-06	Bolt Shoulder 3/8-16 x 3-5/8 Gr. 5
27	532 44 58-80	V-Belt Drive	128	532 17 48-73	Wheel Gauge
32	532 40 18-72	Spring Return Deck	129	532 44 32-37	Rod Anti-Sway
33	580 79 61-01	Mandrel Asm Tall	130	819 13 13-12	Washer 13/32 x 13/16 x 12 Ga.
34	580 85 47-01	Shaft Asm Mndrl N/Greaseable38	131	532 19 42-08	Pin Cotter 5/16 Bow Tie Lock
35	581 51 79-01	Blade Mower LH	136	532 43 96-39	Washout Port Remote Hook-up
36	532 19 30-03	Bolt/Washer Asm 7/16 - 20 unf	137	812 00 00-29	Ring Klip
37	819 13 13-16	Washer 13/32 x 13/16 x 16 Ga.	138	532 44 76-67	Washout Port Hose
40	532 19 72-58	Keeper Belt Engine LH	139	532 44 07-42	Hose 3/8 Clamp
42	817 00 05-12	Screw 5/16-18 x 3/4	140	580 36 99-01	Guard Asm LH
43	532 44 32-39	Pulley Mandrel	141	532 44 77-03	Guard Asm RH
45	581 65 08-01	Mandrel Asm Short	152	532 44 76-66	Cable Clutch Manual w/Spring
67	532 40 30-12	Handle Clutch Cable	154	532 19 98-55	Screw Thd Roll 1/4-20 x 1/2
70	532 19 99-72	Clutch Asm Manual LT Pred	155	532 12 47-88	Retainer Spring 1"
72	581 45 41-02	Chute Upper	247	581 26 34-02	Steel Guard
75	532 13 14-94	Pulley Idler Flat	248	581 26 36-02	LH Rear Steel Guard
76	532 43 96-40	Washout Port	249	581 26 35-02	LH Rear Steel Guard
84	532 44 32-35	Keeper Belt LH Mandrel	250	819 11 12-12	Washer 11/32 x 3/4 x 12 Ga.
85	581 51 80-01	Blade Mower RH	258	584 95 39-01	Bolt Hex Wsh Hd .313-18 x 1.19
86	532 18 17-13	Bolt 3/8-24 x 1.50 Gr. 8	--	580 85 60-01	Mandrel Asm. Tall (Includes Housing (key#33), Shaft Assembly (key#34) and Bearing Only (key#19) - Pulley/Nut/Washer And Blade Bolt/Washers Not Included)
87	810 03 06-00	Washer Lock Hvy. 3/8			
88	532 14 02-96	Washer Hard			
89	532 19 72-61	Arm Brake 97 LH			
90	532 19 90-92	Spacer Retainer			
91	819 13 20-12	Washer 13/32 x 1-1/4 x 12 Ga.	--	581 65 05-01	Mandrel Asm. Short (Includes Housing (key#45), Shaft Assembly (key#124) and Bearing Only (key#19) - Pulley/Nut/Washer And Blade Bolt/Washers Not Included)
92	532 44 32-33	Rod Brake Assembly			
93	532 43 81-25	Arm Brake RH			
94	532 19 72-50	Bracket Clutch Cable			
95	817 00 06-12	Screw 3/8-16 x 3/4			
96	532 40 02-71	Spacer	--	581 96 49-01	Replacement Mower Complete
97	532 18 20-61	Shield Idler Mower			
98	532 19 51-61	Stud Fastener			
99	532 19 51-86	Arm Suspension Mower Rear			
100	532 19 65-39	Bolt Shoulder			
101	873 68 09-00	Nut Crownlock 9/16 - 18 unc			
102	532 40 25-11	Spacer Bearing Swing Plate			
104	581 71 40-01	Mandrel Cover RH			
105	532 44 47-55	Mandrel Cover LH			
106	532 19 32-16	Spring Brake Return			
110	532 41 53-56	Gear Output			

**NOTE:** All component dimensions given in U.S. inches  
1 inch = 25.4 mm



**TRACTOR - MODEL NO. M200-107TC (96051006900), PROD. NO. 960 51 00-69**  
**MOWER LIFT 45**

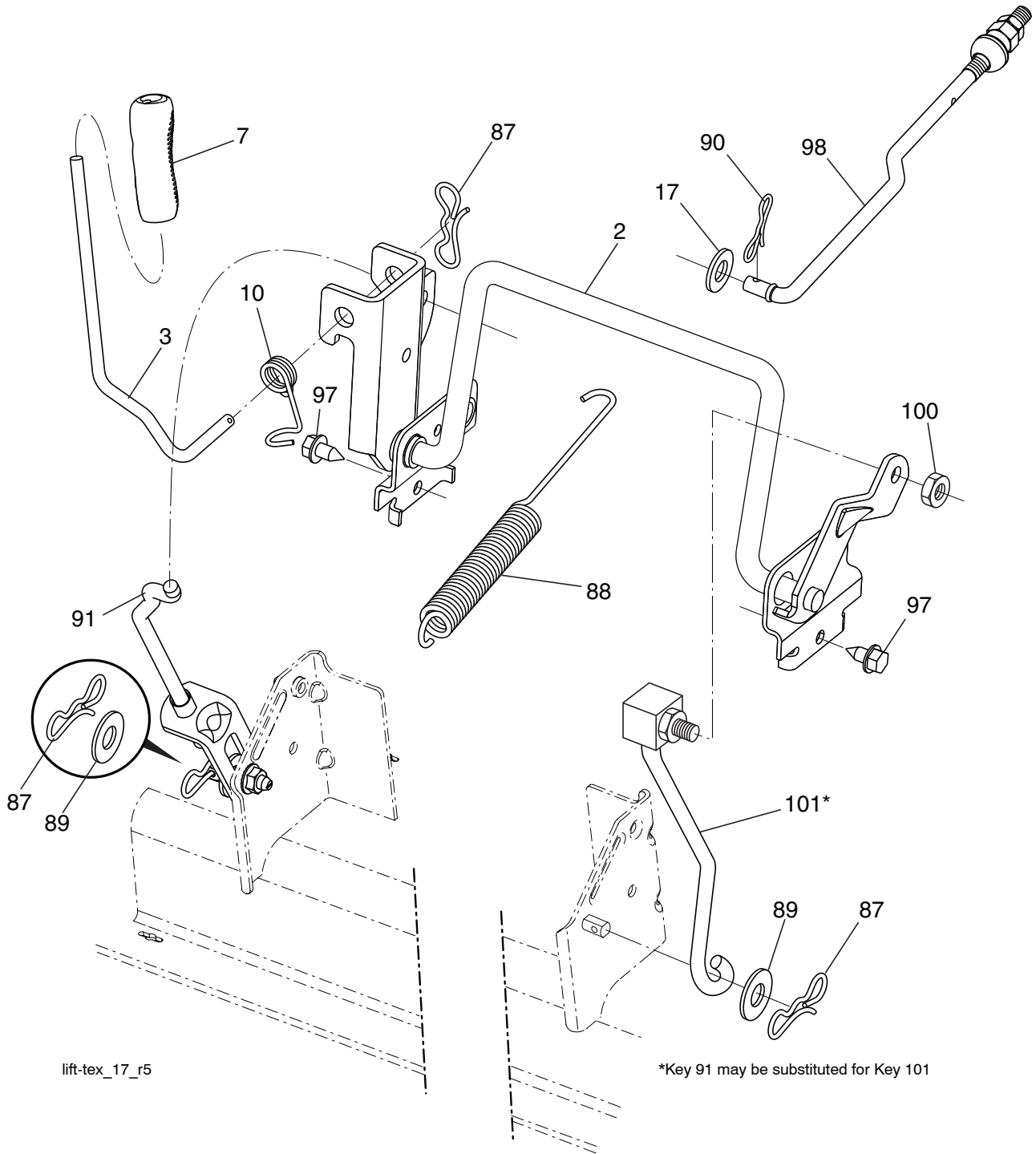

KEY NO.	PART NO.	DESCRIPTION
2	532 43 69-96	Deck Lift
3	532 19 52-31	Lever Asm., Lift RH
7	580 96 23-01	Grip, Lever
10	532 19 63-14	Spring Torsion
17	819 13 13-12	Washer 13/32 x 13/16 x 12 Ga.
87	532 19 42-09	Pin Cotter 7/16 Bow Tie Lock
88	532 44 54-96	Spring Lift Assist
89	819 19 19-12	Washer 17/32 x 1-3/16 x 12 Ga.

KEY NO.	PART NO.	DESCRIPTION
90	532 19 42-08	Pin Cotter 5/16 Bow Tie Lock
91	532 19 51-81	Link Lift Susp Mower Rear
97	817 49 06-08	Screw 3/8-16 x 1/2
98	532 19 52-70	Link Lift Susp. Front Mower
100	873 93 06-00	Nut Centerlock 3/8-16
101	532 40 70-03	Link Asm. Lift Fixed

**NOTE:** All component dimensions given in U.S. inches  
 1 inch = 25.4 mm

**TRACTOR - MODEL NO. M200-107TC (96051006900), PROD. NO. 960 51 00-69  
SEAT ASSEMBLY 42**

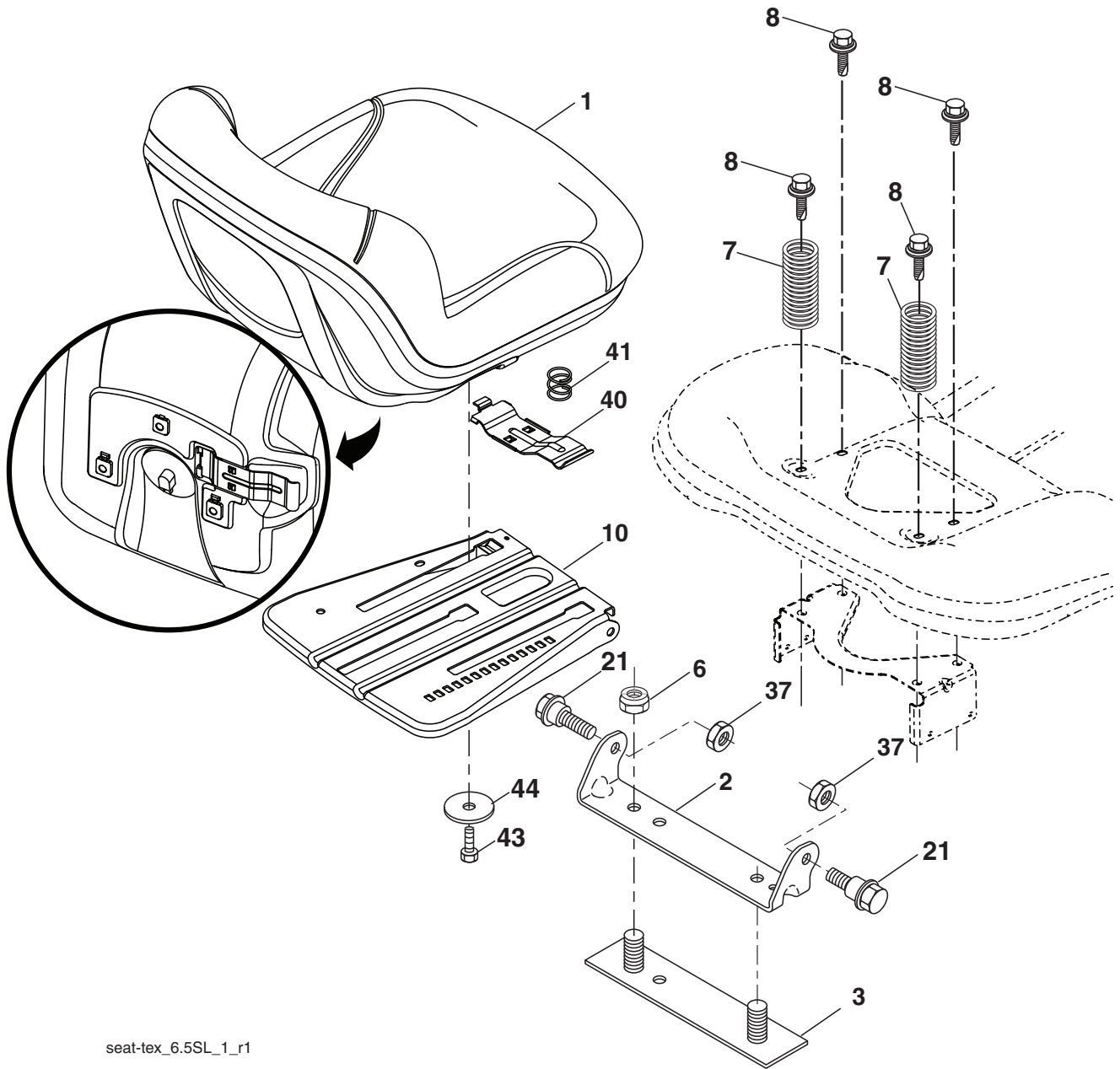

seat-tex\_6.5SL\_1\_r1

KEY NO.	PART NO.	DESCRIPTION
1	581 46 22-01	Seat
2	532 18 01-66	Bracket Pnt Pivot Fender
3	532 14 06-75	Strap
6	873 80 06-00	Nut Lock Hex w/Ins 3/8-16
7	532 12 41-81	Spring Seat Cprsn 2 250 Blk Zi
8	532 17 18-77	Bolt 5/16-18 unc x 3/4
10	532 19 69-77	Pan Pnt Seat
21	532 17 18-52	Bolt Shoulder 5/16-18 unc-2A

KEY NO.	PART NO.	DESCRIPTION
37	873 80 05-00	Nut Hex Lock w/Ins 5/16-18
40	532 19 76-61	Handle Slide
41	532 19 82-00	Spring Latch
43	874 76 06-12	Bolt 3/8-16 unc x 3/4
44	819 13 38-12	Washer 13/32 x 2-3/8 x 12 Ga.

**NOTE:** All component dimensions given in U.S. inches  
1 inch = 25.4 mm

TRACTOR - MODEL NO. M200-107TC (96051006900), PROD. NO. 960 51 00-69  
BAGGER **46**

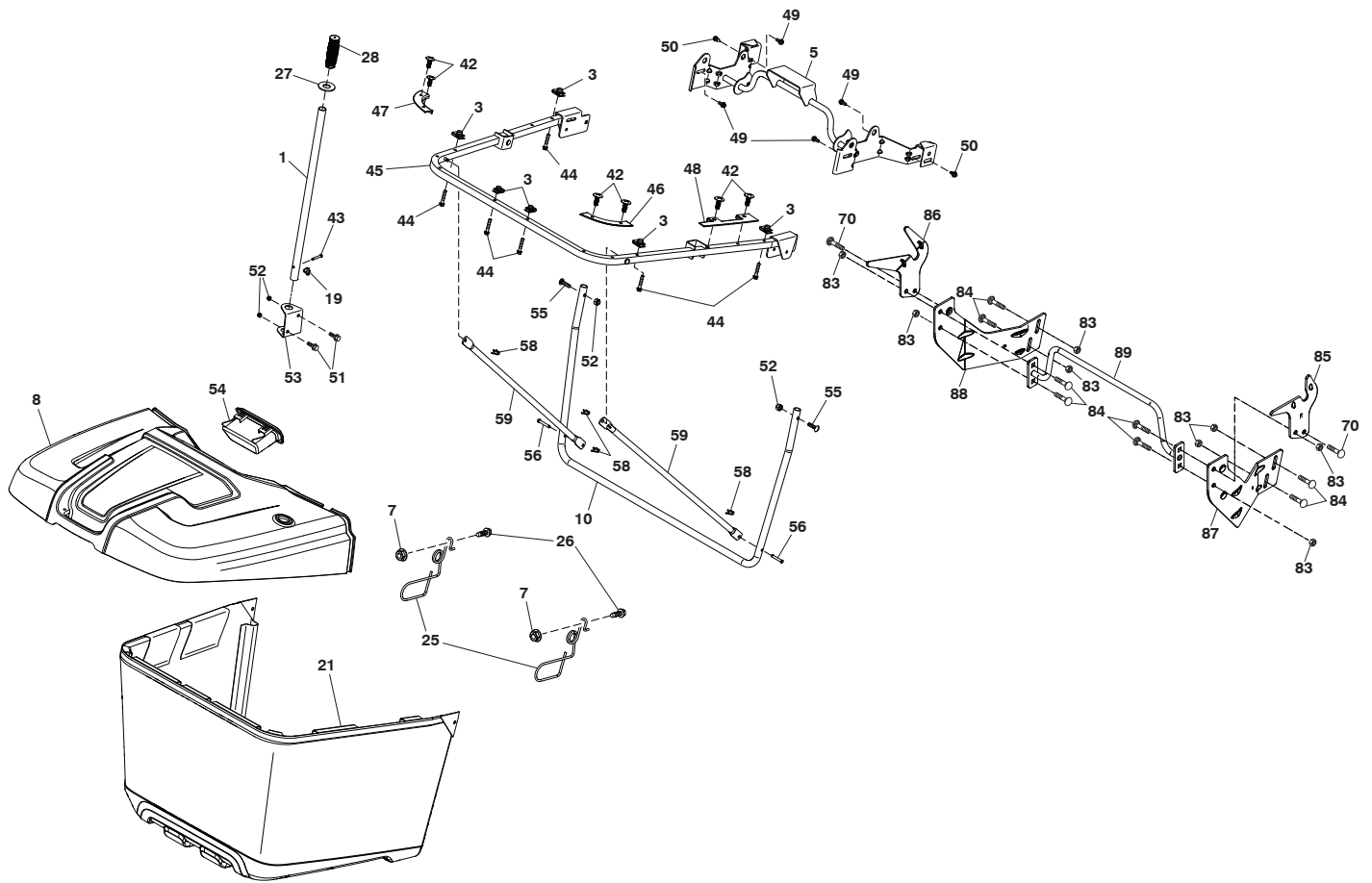

Bagger\_TexCRD-Gen2\_5\_r2

**TRACTOR - MODEL NO. M200-107TC (96051006900), PROD. NO. 960 51 00-69  
BAGGER 46**

<b>KEY NO.</b>	<b>PART NO.</b>	<b>DESCRIPTION</b>
1	532 42 86-10	Tube Handle Bagger
3	532 17 48-14	Nut Push
5	532 44 37-62	Frame Asm Top Bagger
7	873 90 04-00	Nut Hex Flange 1/4-20 unc
8	532 44 78-28	Cover Bagger
10	532 44 37-55	Frame Front
19	532 19 42-08	Cotter Pin 5/16 Bow Tie
21	581 33 71-01	Bag Asm
25	532 44 55-28	Latch Bagger
26	817 49 04-12	Screw Hexwsh Thdrol 1 1/4~20 x 3/4
27	532 44 55-29	Grommet Rubber
28	532 16 57-87	Grip Handle Black
42	532 44 04-28	Christmas Tree Clip
43	532 12 68-75	Clevis Pin
44	532 19 96-87	Bolt 1/4-20 1.50
45	532 44 37-54	Upper U Frame Weldment
46	532 44 55-41	Bagger Corner Close-Out RH
47	532 44 40-79	Bagger Corner Close-Out LH
48	532 44 40-80	Top Bagger Side Close-Out
49	532 17 18-73	Bolt Shoulder 5/16~ 18 TT
50	532 17 18-77	Bolt 5/16-18 unc x 3/4 W/SEMS
51	872 11 05-06	Bolt RDHDSQNK 5/16-18 unc x 3/4
52	873 80 05-00	Nut Lock HX W/INS 5/16-18 UNC
53	532 44 41-95	Bracket Dump Handle
54	532 44 75-43	Bagger TOP Front Handle
55	872 14 05-12	Bolt Rdhd Sq 5/16-18UNCX1 1/2
56	532 42 03-06	Pin Clevis .1830DX1.26 long
58	532 08 51-79	Clip Retainer PM
59	532 44 47-63	Bagger Spread Tube
70	817 00 06-12	Bolt 3/8-16X3/4
83	873 80 06-00	Nut Lock Hex w/Ins 3/8-16
84	872 11 06-08	Bolt RDHD SQNK 3/8-16 x 1 Gr. 5
85	581 31 44-02	Bracket RH Pivot
86	581 31 43-02	Bracket LH Pivot
87	581 31 48-02	Bracket RH
88	581 31 47-02	Bracket LH
89	581 31 51-04	Weldment Offset

**NOTE:** All component dimensions given in U.S. inches  
1 inch = 25.4 mm

