

ILLUSTRATED PARTS LIST

MODEL NO. 96041037800

CUSTOMER CATALOG NO. M185-107T

PRODUCT NO. 960 41 03-78

**TRACTOR -- MODEL NO. M185-107T (96041037800), PRODUCT NO. 960 41 03-78
DECALS 27**

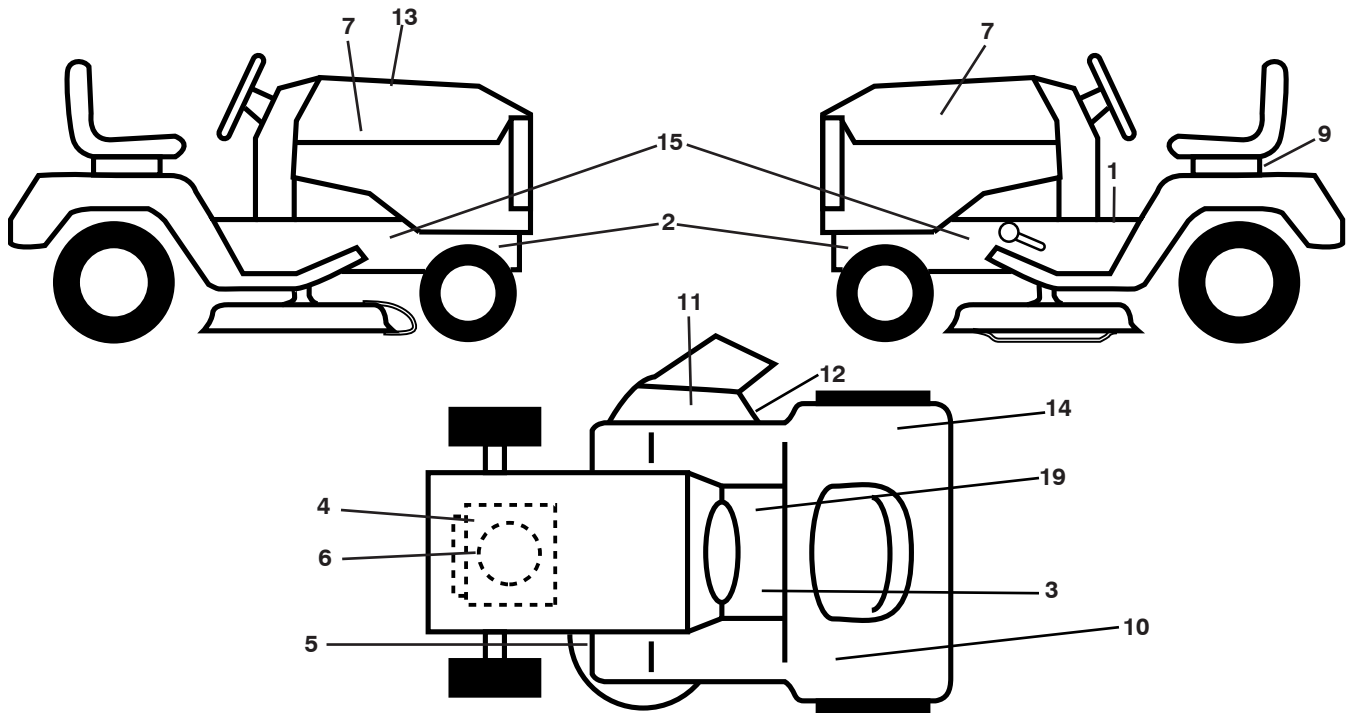

KEY NO.	PART NO.	DESCRIPTION
1	581 57 81-01	Decal, Warning Sym.
2	581 57 98-01	Decal, Warning Service/Fire
3	581 72 40-01	Decal, Saddle Brake Clutch
4	581 57 97-01	Decal, Warning Engine
5	581 58 00-01	Decal, V-Belt Sch.
6	532 43 74-20	Decal, Eng. HP
7	581 09 12-01	Decal, Hood LH/RH
9	532 14 50-05	Decal, Battery Dnge/Poi
10	587 20 28-01	Decal, Fender Side
11	584 90 46-01	Decal, Deflect. Warning
12	581 57 92-01	Decal, Deflector Warning
13	581 59 18-01	Decal, Replacement

KEY NO.	PART NO.	DESCRIPTION
14	581 72 41-01	Decal, Certification
15	581 57 96-01	Decal, Hot Muffler
19	581 57 80-01	Decal, Saddle Brake Parking
--	581 72 48-01	Decal, Bypass
--	581 72 46-01	Decal, Load Limit
--	532 40 95-05	Pad, Footrest, LH
--	532 40 95-07	Pad, Footrest, RH
--	587 21-99-40	Manual, Oper Euro
--	587 21-99-50	Manual, Oper Scan
--	587 21-99-20	Manual, Oper EBlock
--	587 21-99-30	Manual, Oper Baltic

WHEELS AND TIRES

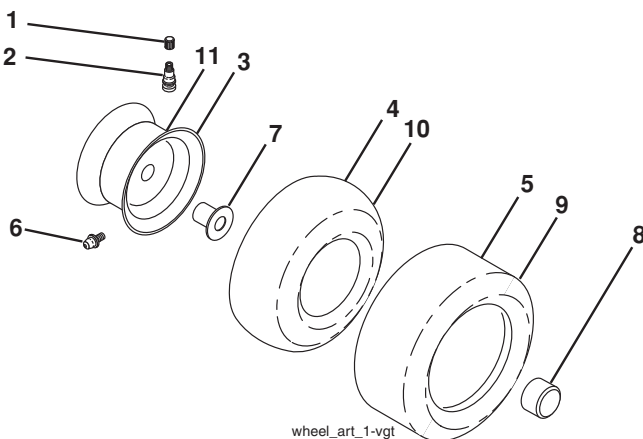

KEY NO.	PART NO.	DESCRIPTION
1	532 05 91-92	Cap, Valve, Tire
2	532 06 51-39	Stem, Valve
3	532 12 51-21	Rim Assembly, Front
4	532 05 99-04	Tube, Front (Service Item Only)
5	532 10 62-22	Tire, Front 15 x 6-6
6	532 12 49-57	Fitting, Grease (Front Wheel Only)
7	532 12 49-59	Bearing, Flange (Front Wheel Only)
8	532 19 32-68	Cap, Axle
9	532 13 84-68	Tire, Rear 20 x 8-8
10	532 12 49-26	Tube, Rear (Service Item Only)
11	532 12 51-22	Rim Assembly, Rear
--	532 14 43-34	Sealant, Tire (10 oz. Tube)

NOTE: All component dimensions given in U.S. inches
1 inch = 25.4 mm

TRACTOR - - MODEL NO. M185-107T (96041037800), PRODUCT NO. 960 41 03-78

SCHEMATIC 38

SCH10

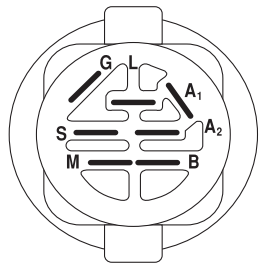
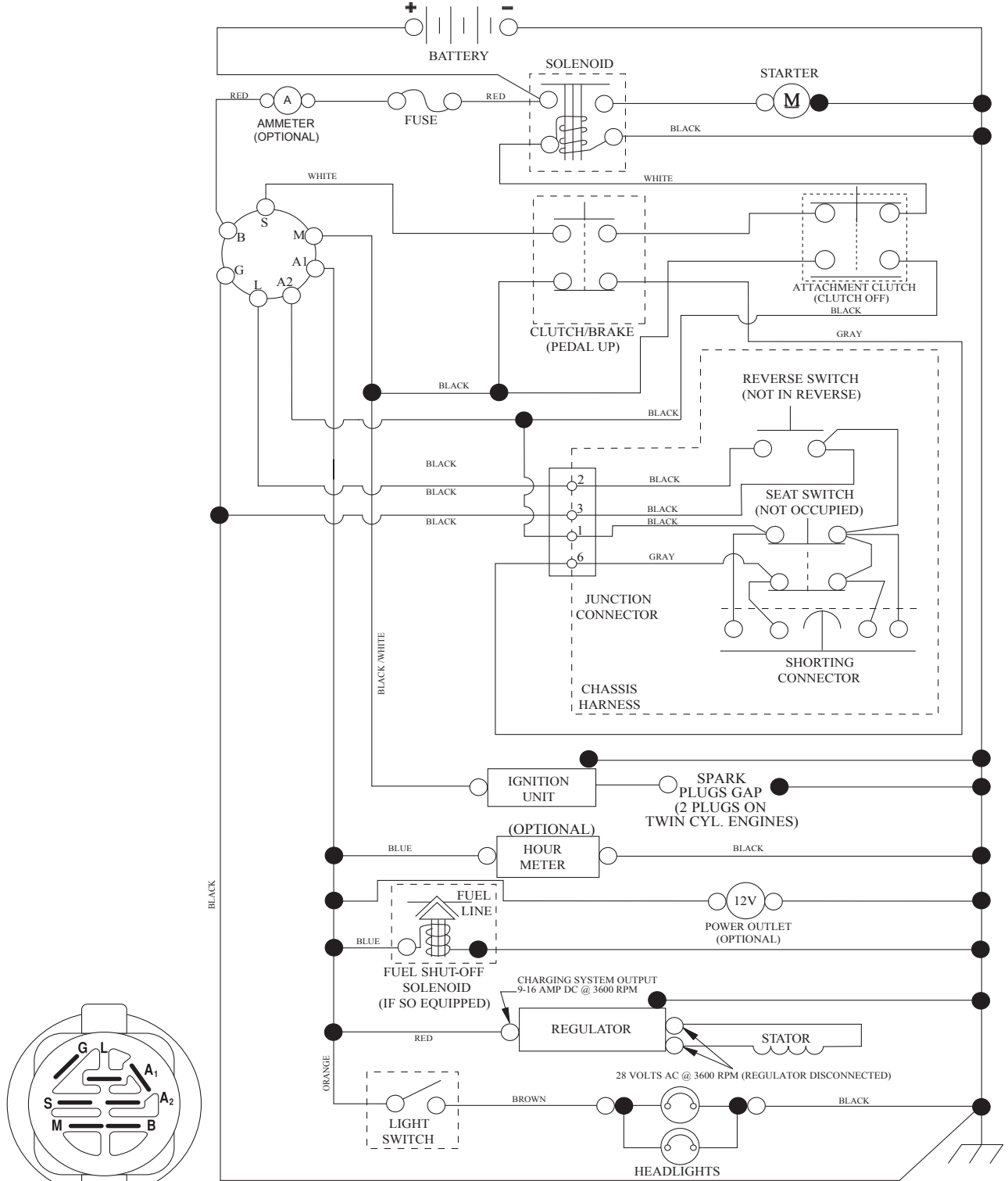

IGNITION SWITCH

POSITION	CIRCUIT	"MAKE"
OFF	M+G+A1	
RUN/OVERRIDE	B+A1	
RUN	B+A1	L+A2
START	B + S + A1	

03107

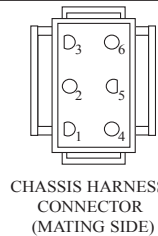

CHASSIS HARNESS CONNECTOR (MATING SIDE)

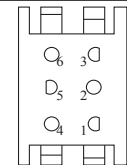

DASH HARNESS CONNECTOR (MATING SIDE)

WIRING INSULATED CLIPS
NOTE: IF WIRING INSULATED CLIPS WERE REMOVED FOR SERVICING OF UNIT, THEY SHOULD BE RE-INSTALLED TO PROPERLY SECURE YOUR WIRING.

NON-REMOVABLE CONNECTIONS

REMOVABLE CONNECTIONS

TRACTOR - - MODEL NO. M185-107T (96041037800), PRODUCT NO. 960 41 03-78
ELECTRICAL 32

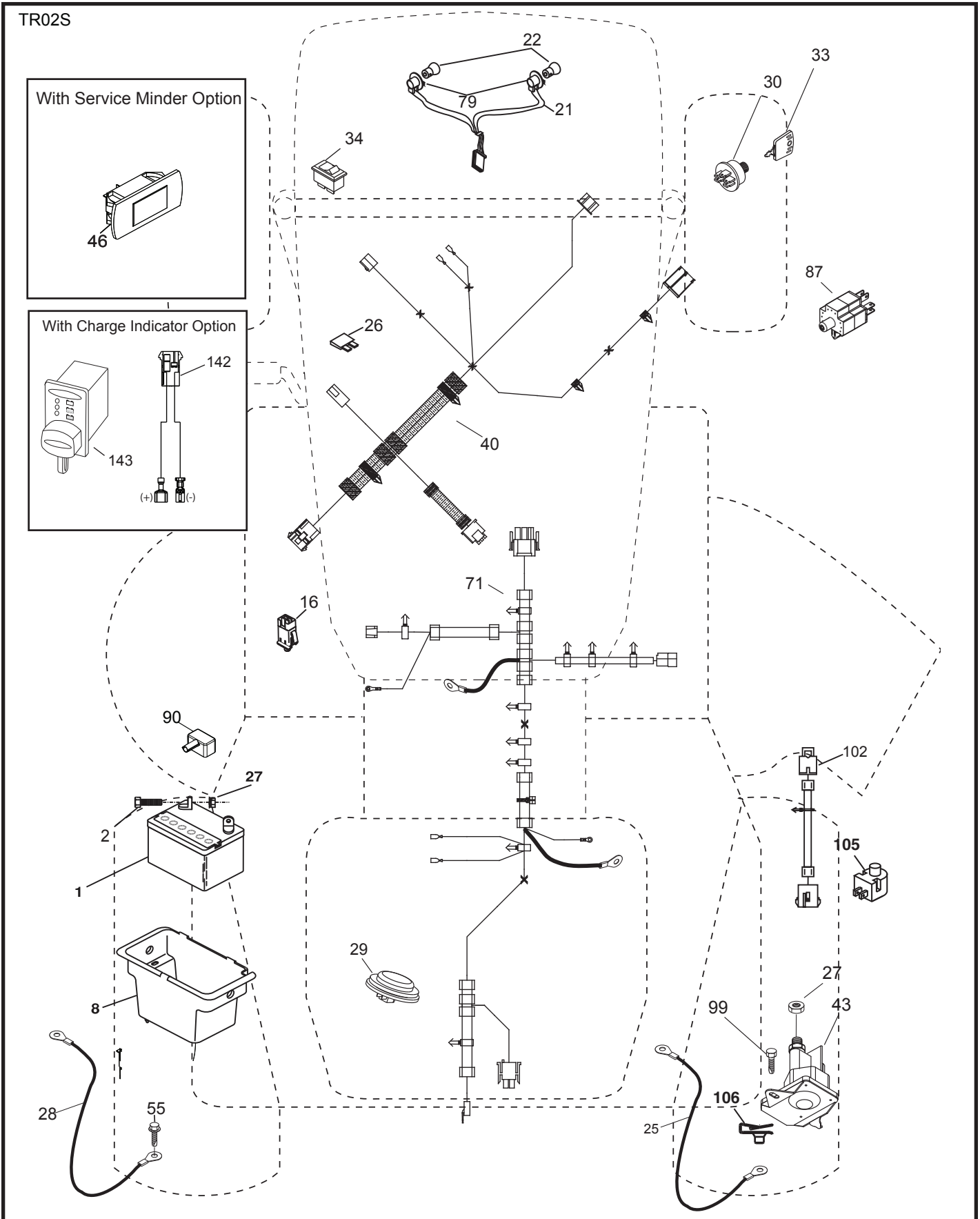

**TRACTOR - - MODEL NO. M185-107T (96041037800), PRODUCT NO. 960 41 03-78
ELECTRICAL 32**

KEY NO.	PART NO.	DESCRIPTION
1	532 16 34-65	Battery
2	874 76 04-12	Bolt Hex Hd 1/4-20 unc x 3/4
8	532 19 32-28	Battery Box
16	532 17 61-38	Switch Interlock
21	532 40 02-52	Harness Socket Light
22	532 00 41-52	Bulb, Light # 1156
25	581 49 80-01	Cable Starter
26	532 17 51-58	Fuse
27	873 51 04-00	Nut Keps Hex 1/4-20 unc
28	532 42 16-86	Cable Ground
29	532 40 15-45	Switch Seat
30	532 19 33-50	Switch Ign
33	532 41 19-35	Key/Chain
34	532 11 07-12	Switch Light/Reset
40	581 02 31-01	Harness Ign. Dash
43	532 19 25-07	Solenoid
55	817 06 05-12	Screw Thdrol 5/16-18 x 3/4
71	581 02 30-01	Harness Ign. Chassis
79	532 17 52-42	Socket Asm. Bulb
87	532 19 78-02	Switch Interlock
90	532 43 53-95	Cover Terminal Battery
99	817 67 04-12	Screw 1/4-20 x 3/4
102	581 02 34-01	Harness Pigtail
105	532 40 75-68	Switch Reverse
106	532 17 48-14	Palnut 1/4 Lugs

NOTE: All component dimensions given in U.S. inches
1 inch = 25.4 mm

**TRACTOR - - MODEL NO. M185-107T (96041037800), PRODUCT NO. 960 41 03-78
CHASSIS AND ENCLOSURES 39**

KEY NO.	PART NO.	DESCRIPTION	KEY NO.	PART NO.	DESCRIPTION
5	532 44 66-39	Dash	201	819 13 20-16	Washer 13/32 x 1-1/4 x 16 Ga.
14	532 44 80-42	Hood	202	581 85 91-01	Side Vent RH
15	581 10 31-01	Lens LH	203	581 85 92-01	Side Vent LH
18	581 10 29-01	Grille	213	874 76 05-12	Bolt 5/16-18 x 3/4
25	581 10 30-01	Lens RH	217	532 40 91-67	Rod Pivot Hood
34	580 91 08-01	Plate Engine	218	532 19 63-95	X-Piece Hood Stop
36	817 06 05-12	Screw 5/16-18 x 3/4	225	581 10 32-01	Trim Ring
37	532 42 07-96	Fender	226	578 89 71-01	Emblem
52	873 68 05-00	Nut Crown Lock 5/16	228	532 19 51-61	Stud Fastener
58	532 41 22-80	Drawbar Upper	235	532 40 61-29	Spacer Fender
68	817 49 05-08	Screw THDROL 5/16-18 x 1/2	236	873 93 05-00	Nut Lock 5/16-18 unc
130	532 41 63-58	Screw	237	532 40 37-04	Plug Mount Cargo
138	532 40 97-30	Cupholder	287	817 60 04-06	Screw Hex Washhead 1/4-20 x 3/8
150	584 86 29-03	Air Duct	297	581 22 36-01	Reflector LH
151	532 44 54-94	Bracket Pivot	303	587 49 34-02	Shield Chassis French LH
152	532 19 95-35	Shield Browning	304	587 86 51-02	Shield Chassis French RH
159	817 00 06-12	Screw 3/8-16 x 3/4	307	587 49 46-01	Shield Upper Pedal
162	532 14 24-32	Screw 1/4 x 1/2	308	532 17 18-77	Bolt 5/16-18 unc x 3/4
175	532 19 63-04	Crossmember	312	587 49 30-02	Shield Drawbar
176	532 40 07-76	Screw 10-24 x 5/8	--	532 44 11-26	Plug Dash SRVMNDR.
177	532 19 52-27	Bushing Steering	--	532 40 09-44	Bumper Kit
180	532 41 50-63	Chassis			
181	532 40 47-96	Bushing Mtg. Fender Crgo			
182	532 40 68-59	Dash Lower			
183	874 52 05-20	Bolt 5/16-18 x 1-1/4			
184	587 55 41-01	Plug			
189	817 00 05-12	Screw 5/16-18 x 3/4			
191	581 22 35-01	Reflector RH			
194	873 90 05-00	Nut Lock Hex Flange 5/16-18			
195	532 40 41-37	Plug Hole Dash Lower			
196	532 41 45-81	Console Asm. Deck Lift			

NOTE: All component dimensions given in U.S. inches
1 inch = 25.4 mm

TRACTOR -- MODEL NO. M185-107T (96041037800), PRODUCT NO. 960 41 03-78
DRIVE **40**

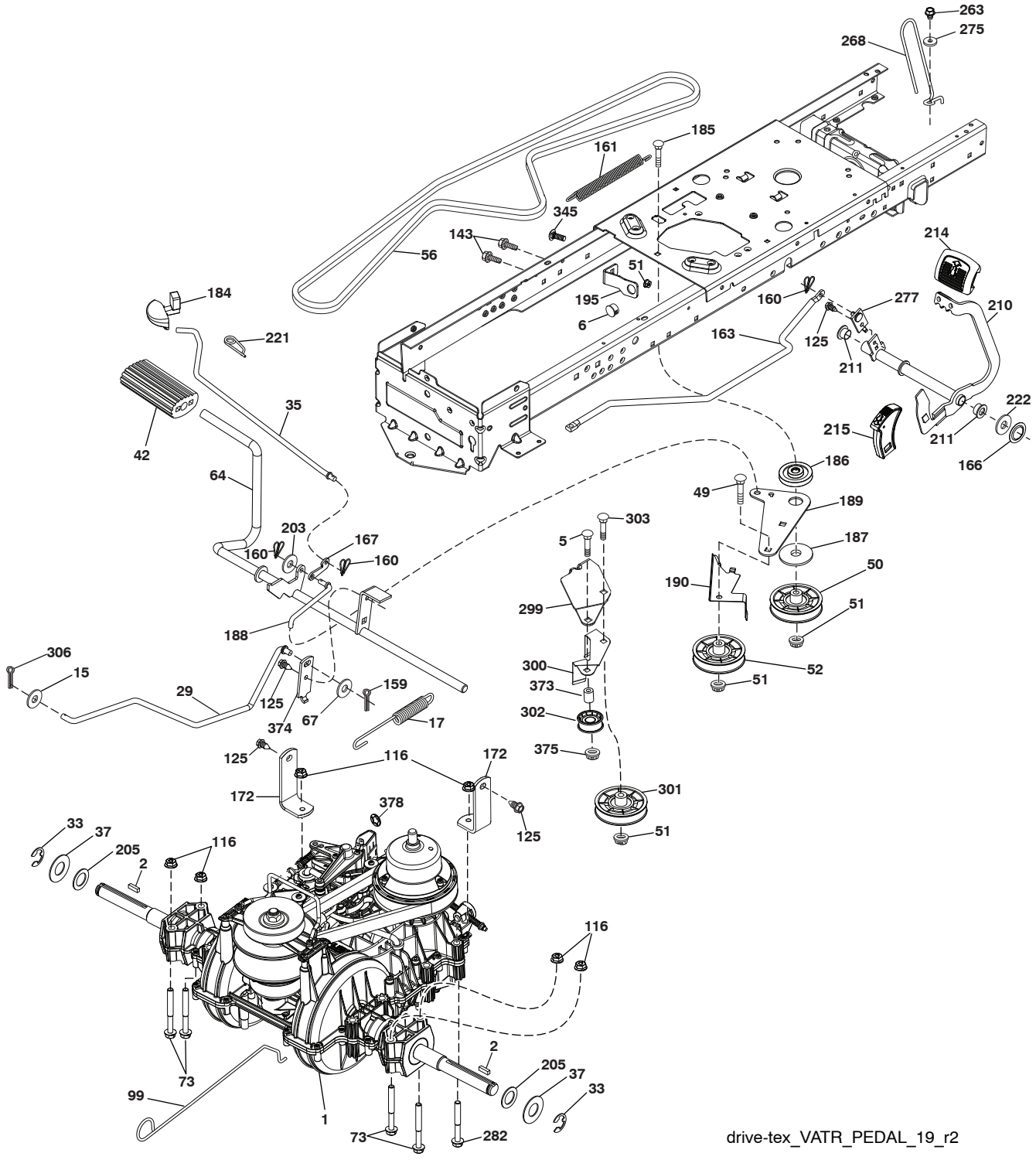

drive-tex_VATR_PEDAL_19_r2

**TRACTOR - - MODEL NO. M185-107T (96041037800), PRODUCT NO. 960 41 03-78
DRIVE 40**

KEY NO.	PART NO.	DESCRIPTION	KEY NO.	PART NO.	DESCRIPTION
1	---	Transmission, Gentrans VATR. (580486201) (Order parts from transaxle manufacturer.)	188	532 19 43-23	Link.Clutch.Ground Drive
2	532 12 35-83	Key.Square .2.0 x .1845/.1865	189	532 19 43-17	Bellcrank.Groundrive.Nstg/Nstl
5	874 76 06-36	Bolt Hex	190	532 19 43-18	Keeper.Bellcrank.Drive.Ground
6	532 12 40-28	Bushing Snap	195	581 50 46-01	Brake Bracket
15	819 13 13-16	Washer 13/32 x 13/16 x 16 Ga.	203	819 11 11-16	Washer 11/32 x 11/16 x 16
17	584 95 40-01	Spring Brake	205	532 12 17-48	Washer.25/32 x 1-5/8 x 16 Ga.
29	584 82 31-01	Rod Brake	210	532 44 82-70	Weldment Pedal
33	812 00 00-01	E-Ring. #5133-75	211	532 12 01-83	Bearing Nylon
35	583 86 45-01	Rod.Brake.Parking	214	532 42 12-63	Pedal Forward Pad
37	532 18 89-67	Washer Hard .793 x 1.637 x 060	215	532 44 82-54	Cap Pedal Reverse
42	532 12 48-72	Cover.Pedal.Blk.Round	221	532 40 31-87	Retainer.Spring.Clip.Handle
49	872 11 06-14	Bolt.Rdhd.3/8-16Uncx1-3/4.Gr 5	222	879 21 20-10	Washer 21/32 x 1-1/4 10 Ga.
50	532 19 43-27	Idler.Flat	263	817 00 06-12	Screw 3/8-16 x 3/4
51	873 90 06-00	Nut, Hex, Flangelock 3/8-16	268	532 18 24-02	Guard Muffler
52	532 19 43-26	Idler.V-Groove.Offset	275	819 13 16-14	Washer 13/32 x 1 x 14 Ga.
56	581 60 38-01	Belt Drive	277	532 44 85-00	Link Rocker Pedal
64	532 44 83-53	Shaft Asm. Pedal Brake	282	874 49 05-48	Screw Thdrol 5/16-18 x 3
67	819 13 13-12	Washer 13/32 x 13/16 x 12 Ga.	299	532 41 56-83	Bracket Mount Idler
73	874 49 05-44	Bolt.Hex.Flghd.5/16-18.Gr.5	300	532 41 56-81	Keeper Idler Rear
99	532 43 59-35	Rod Bypass	301	532 41 56-80	Pulley Idler V-Groove
116	873 90 05-00	Nut, Lock Hex Flange 5/16-18 unc	302	581 42 05-01	Pulley Idler Flat 2.0 Od
125	817 00 05-12	Screw.5/16-18 x 3/4.Smgml.Tap/Bl	303	872 11 06-18	Bolt Rdhd Sgnk 3/8-16 x 2-1/4
143	817 49 05-08	Screw.Thdrol.5/16-18 x 1/2 Tytt	306	876 02 04-16	Pin Cotter
159	876 02 04-12	Pin Cotter 1/8 x 3/4	345	872 11 06-06	Bolt Rdhd Sgnk 3/8-16 x 1 Gr. 5
160	532 16 94-84	Retainer.Clip(M).Dia.290	373	581 46 18-01	Spacer Idler
161	532 10 57-09	Spring.Return.Clutch.6.75	374	581 47 52-01	Bracket Brake Arm
163	583 97 13-01	Rod Control Pedal	375	873 68 06-00	Nut Crownlock
166	532 42 91-64	Nut Push .625	378	584 28 77-01	Nut Push 8 mm
167	532 40 52-57	Latch.Brake.Parking			
172	583 97 42-01	Strap Torque LH/RH			
184	587 65 37-01	Handle.Parking Brake			
185	872 11 06-22	Bolt.Rdhd.3/8-16Unc x 2-3/4 Gr.5			
186	532 19 43-21	Spacer.Retainer			
187	819 13 32-10	Washer.13/32 x 2 x 10 Ga.			

NOTE: All component dimensions given in U.S. inches
1 inch = 25.4 mm

TRACTOR -- MODEL NO. M185-107T (96041037800), PRODUCT NO. 960 41 03-78
ENGINE **24**

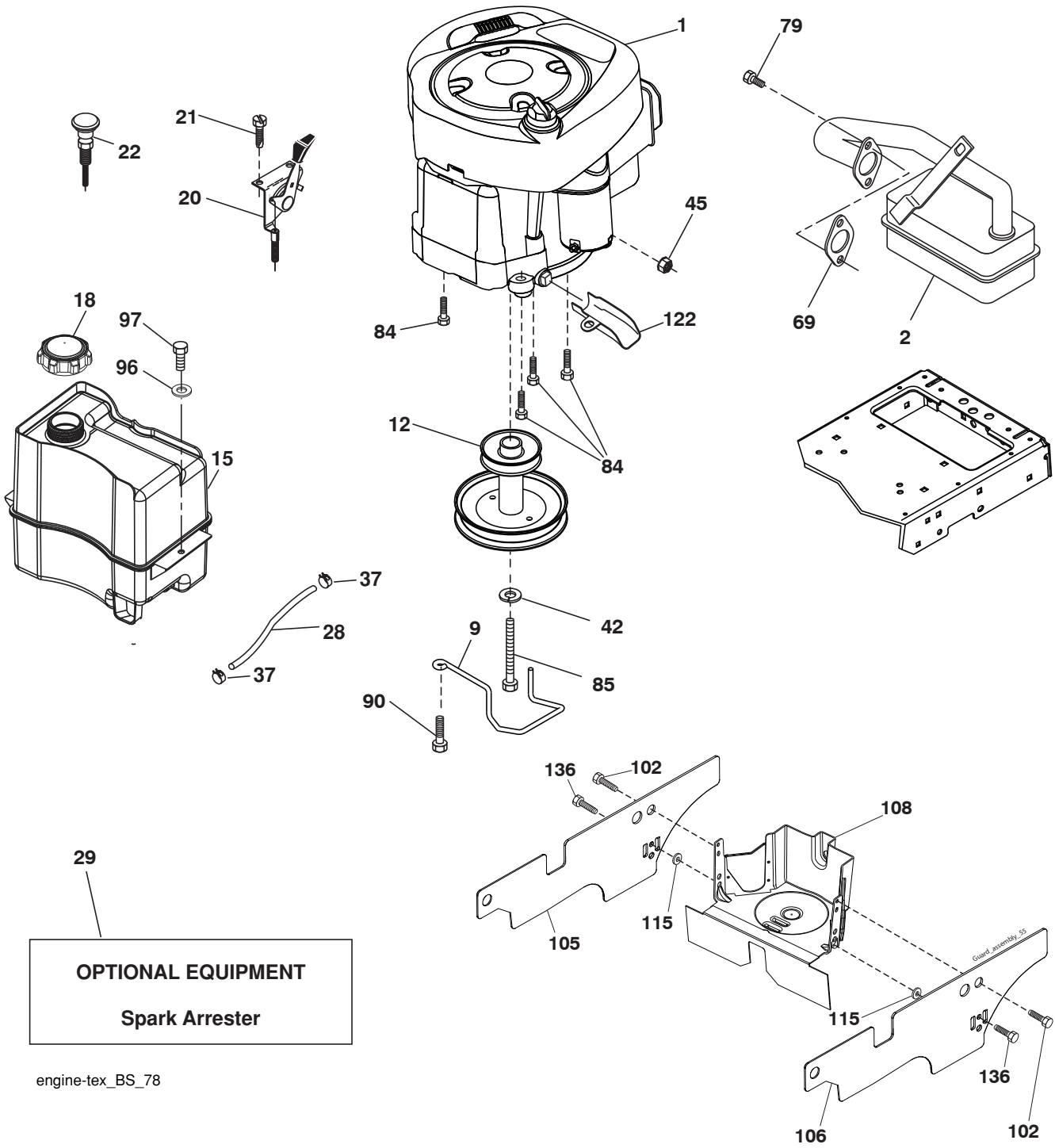

engine-tex_BS_78

**TRACTOR - - MODEL NO. M185-107T (96041037800), PRODUCT NO. 960 41 03-78
ENGINE 24**

KEY NO.	PART NO.	DESCRIPTION
1	— — — — —	Engine Briggs Model No. 31R807-0007-B1 (585689101) (Order parts from engine manufacturer.)
2	532 13 73-52	Muffler
9	584 90 80-01	Keeper Belt Engine
12	532 40 54-71	Pulley Engine
15	532 40 75-51	Tank Fuel
18	532 43 02-20	Cap Asm
20	532 18 38-97	Control Throttle
21	532 41 63-58	Screw #10 x 0.750 BOS Thread
22	532 19 49-81	Control Choke
28	532 13 70-40	Fuel Line
29	532 13 71-80	Spark Arrester Kit
37	532 12 34-87	Clamp Hose
42	810 04 07-00	Washer Lock 7/16
45	873 51 04-00	Nut Keps Hex 1/4-20 unc
69	532 16 52-91	Gasket
79	532 19 23-34	Screw 5/16-18 x .75
84	817 06 06-20	Screw 3/8-16 x 1-1/4
85	532 17 39-37	Bolt 7/16-20 x 4
90	817 00 06-16	Screw 3/8-16 x 1
96	819 09 14-16	Washer 9/32 x 7/8 x 16 Ga.
97	817 67 04-12	Screw 1/4 - 20 x 3/4
102	817 00 05-12	Screw
105	532 41 05-28	Shield Side LH
106	532 41 05-29	Shield Side RH
108	532 42 17-94	Cover Asm. Pulley
115	532 42 30-62	Palnut 1/4
122	532 42 19-22	Extension Drain Oil
136	532 13 77-29	Screw Thdrol 1/4-20 x 5/8

NOTE: All component dimensions given in U.S. inches
1 inch = 25.4 mm

Engine Power Rating Information

The gross power rating for individual gas engine models is labeled in accordance with SAE (Society of Automotive Engineers) code J1940 (Small Engine Power & Torque Rating Procedure), and rating performance has been obtained and corrected in accordance with SAE J1995 (Revision 2002-05). Torque values are derived at 3060 RPM; horsepower values are derived at 3600 RPM. Actual gross engine power will be lower and is affected by, among other things, ambient operating conditions and engine-to-engine variability. Given both the wide array of products on which engines are placed and the variety of environmental issues applicable to operating the equipment, the gas engine will not develop the rated gross power when used in a given piece of power equipment (actual "on-site" or net power). This difference is due to a variety of factors including, but not limited to, accessories (air cleaner, exhaust, charging, cooling, carburetor, fuel pump, etc.), application limitations, ambient operating conditions (temperature, humidity, altitude), and engine-to-engine variability. Due to manufacturing and capacity limitations, Briggs & Stratton may substitute an engine of higher rated power for this Series engine.

TRACTOR -- MODEL NO. M185-107T (96041037800), PRODUCT NO. 960 41 03-78
STEERING ASSEMBLY **41**

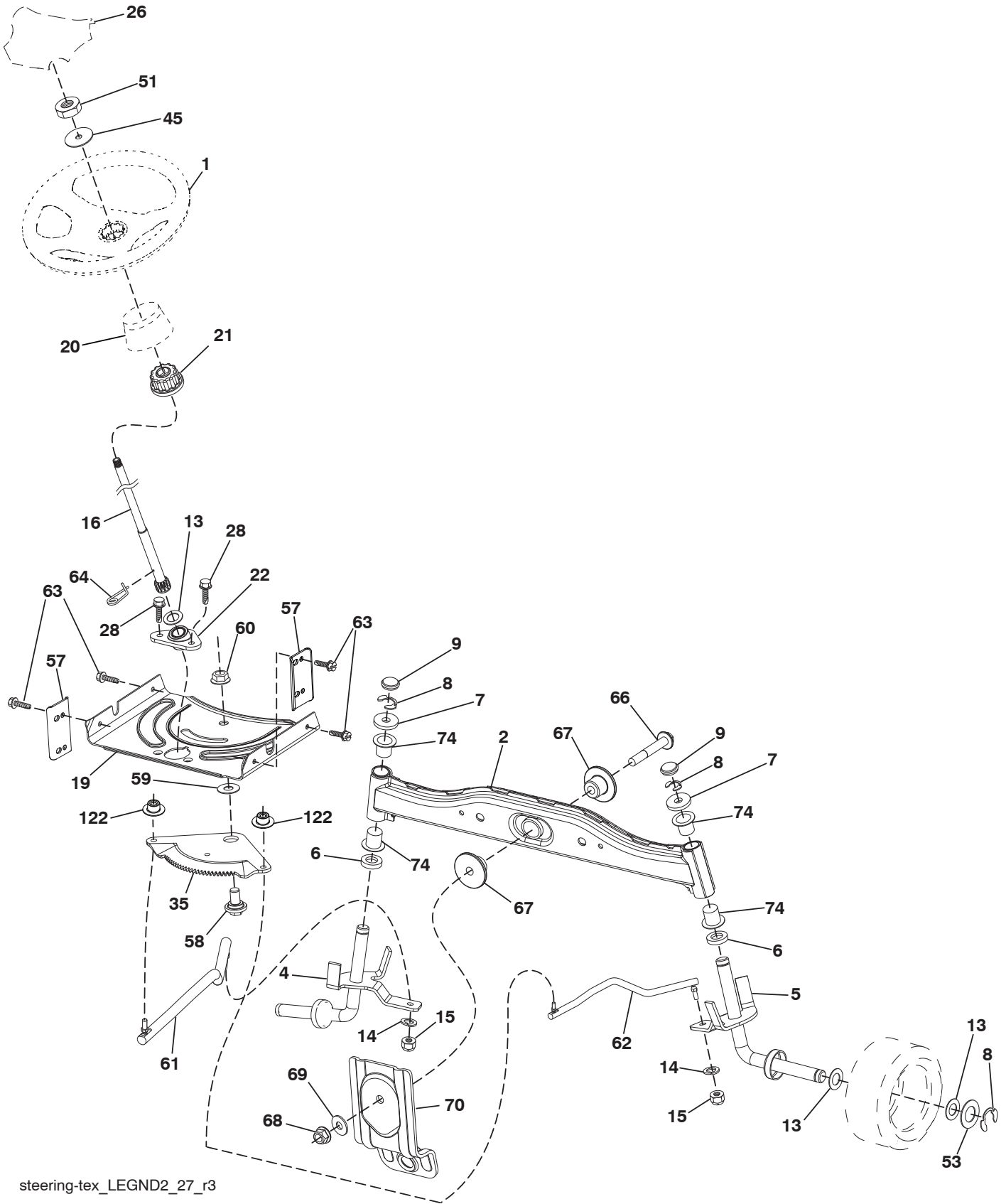

steering-tex_LEGND2_27_r3

**TRACTOR - - MODEL NO. M185-107T (96041037800), PRODUCT NO. 960 41 03-78
STEERING ASSEMBLY 41**

KEY NO.	PART NO.	DESCRIPTION
1	532 44 28-04	Wheel, Steering
2	532 41 81-68	Axle Asm., Front
4	532 40 30-87	Spindle Asm., LH
5	532 40 30-88	Spindle Asm., RH
6	532 12 49-31	Bearing, Race Thrust Harden
7	532 12 17-48	Washer 25/32 x 1-5/8 x 16 Ga.
8	812 00 00-29	Ring, Clip #T5304-75
9	532 12 12-32	Cap, Spindle
13	532 12 17-49	Washer 25/32 x 1-1/4 x 16 Ga.
14	810 04 06-00	Washer, Lock Hvy Hlcl Spr 3/8
15	873 54 06-00	Nut, Crown Lock 3/8-24 unf
16	532 19 47-46	Shaft Steering
19	532 19 47-29	Plate Steering
20	532 42 47-40	Boot Steering
21	532 18 67-37	Adapter, Wheel Steering
22	532 42 05-37	Steering Support Lower
26	532 44 77-59	Insert, Wheel Steering
28	817 00 06-12	Screw 3/8-16 x 3/4
35	532 19 47-32	Gear, Sector Plate
45	819 18 38-12	Washer 9/16 x 2-3/8 12 Ga.
51	873 94 08-00	Nut Hex Jam Toplock 1/2-20 unf
53	532 18 89-67	Washer Hardened .793 x 1.637 x .060
57	532 40 74-65	Bracket Upstop
58	532 19 47-47	Bolt Shoulder Sector Pivot CFM
59	532 19 47-48	Washer Thrust Sector Steering
60	873 97 10-00	Nut Flange Lock 5/8-11
61	532 19 47-40	Draglink LH
62	532 19 47-41	Draglink, RH
63	817 00 05-12	Screw 5/16-18 x 3/4
64	532 19 98-49	Retainer Clip Spring Steering
66	871 02 07-48	Bolt Hex Fghd 7/16-14 x 3 Serr
67	532 19 47-37	Bushing PM Front Axle
68	873 90 07-00	Nut Lock Flange 7/16-14 Gr. 5
69	532 19 91-62	Washer 1.5 x .505 x .118
70	585 33 88-01	Bracket Deck Susp. Front
74	532 12 49-37	Bearing
122	532 44 49-62	Cap Gear Sector

NOTE: All component dimensions given in U.S. inches
1 inch = 25.4 mm

TRACTOR - - MODEL NO. M185-107T (96041037800), PRODUCT NO. 960 41 03-78
MOWER DECK 44

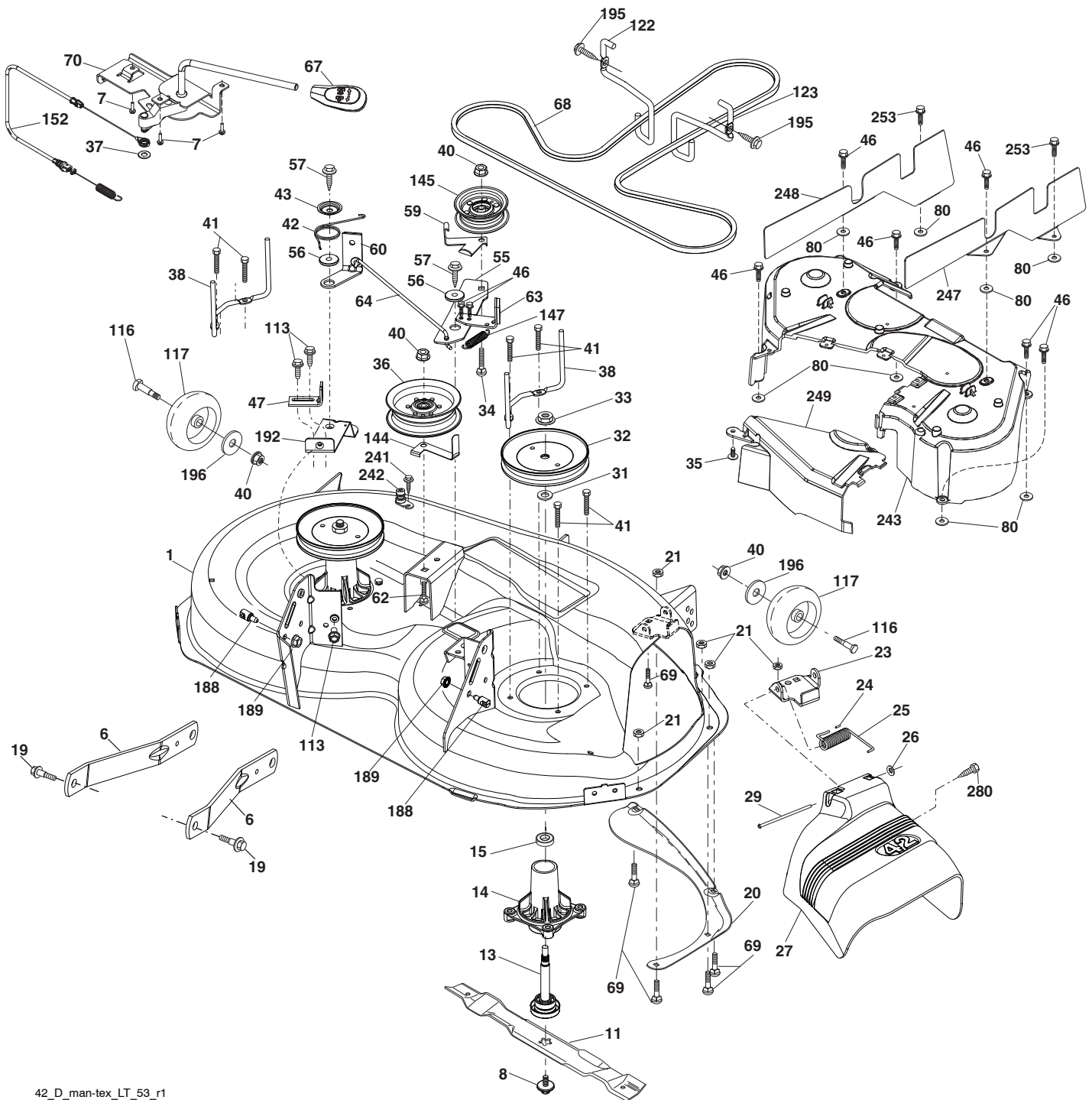

42_D_man-tex_LT_53_r1

**TRACTOR - - MODEL NO. M185-107T (96041037800), PRODUCT NO. 960 41 03-78
MOWER DECK 44**

KEY NO.	PART NO.	DESCRIPTION	KEY NO.	PART NO.	DESCRIPTION
1	532 19 64-95	Mower Housing	67	532 40 30-12	Handle, Clutch Cable
6	532 19 51-86	Arm Suspension	68	532 42 96-36	V-Belt
7	532 41 63-58	Screw #10 x 0.750	69	872 14 05-05	Bolt Rdhd. Sqnk. 5/16-18 x 5/8
8	532 19 30-03	Bolt/Washer Asm. 7/16-20 unf	70	532 40 12-46	Clutch Asm. Manual
11	532 13 89-71	Blade, 42" Hi-Lift (For bagging or discharge)	80	532 42 30-62	Palnut 1/4
13	532 19 28-72	Shaft Assembly, Mandrel	113	817 00 05-10	Screw 5/16-18
14	532 18 72-81	Housing, Mandrel	116	532 12 48-42	Bolt, Shoulder
15	532 11 04-85	Bearing, Ball, Mandrel	117	532 18 86-06	Wheel, Gauge
19	532 19 65-39	Bolt, Shoulder	122	532 19 72-58	Keeper Belt Eng. LH
20	532 15 97-70	Baffle, Vortex	123	532 19 72-59	Keeper Belt Eng. RH
21	873 68 05-00	Nut Crown Lock 5/16-18	144	532 19 92-04	Keeper Belt
23	532 19 25-57	Bracket, Deflector	145	532 19 31-97	Pulley, Idler, Flat
24	532 10 53-04	Cap, Sleeve	147	532 40 19-71	Spring Return
25	532 19 70-26	Spring, Torsion, Deflector	152	584 24 35-01	Cable Mechanical Clutch
26	532 11 04-52	Nut, Push	188	532 19 51-61	Stud Fastener
27	532 41 14-85	Shield, Deflector	189	873 90 05-00	Nut Lock Hex Flange
29	532 13 14-91	Rod, Hinge	192	532 19 72-60	Bracket Brake Stand LH
31	532 18 76-90	Washer, Spacer	195	817 00 06-12	Screw Hex Wsh. Thdrol. 3/8-16 x 3/4
32	532 19 74-73	Pulley, Mandrel	196	819 12 14-14	Washer 13/32 x 7/8 x 14 Ga.
33	532 40 02-34	Nut, Toplock, Flanged	241	532 15 29-27	Screw
34	872 11 06-12	Bolt Carr. Sh. 3/8-16 x 1-1/2 Gr. 5	242	532 41 55-98	Port Washout
35	532 13 38-35	Fastener	243	532 43 23-94	Cover Deck 42"
36	532 19 73-79	Pulley Idler	247	532 43 02-61	Shield Deck RH
37	819 13 13-16	Washer 13/32 x 13/16 x 16 Ga.	248	532 43 02-60	Shield Deck LH
38	532 43 25-20	Keeper Belt Mandrel	249	532 40 65-14	Cover Cable Clutch
40	873 90 06-00	Nut, Lock Flg. 3/8-16 unc	253	532 42 73-50	Rivot Tuflock
41	584 95 39-01	Bolt Hex Wash HD .313-18 x 1.19	280	817 67 06-08	Screw Thdrol 3/8-16 x 1/2
42	532 19 84-10	Spring Trosion Brake	--	532 19 28-70	Mandrel Assembly (Includes housing (key #14), shaft assembly (key #13) and bearing only (key #15) - Pulley/Nut/Washer and Blade Bolt/Washers not included)
43	532 19 72-56	Spring Torsion Retainer	--	532 43 77-30	Replacement Mower, Complete
46	532 13 77-29	Screw Thdrol. 1/4-20 x 5/8			
47	532 19 72-50	Bracket Clutch Cable			
55	532 43 71-10	Arm, Idler			
56	532 19 90-92	Spacer, Retainer			
57	817 00 06-16	Screw Hex Wsh. Thd. 3/8-16 x 1			
59	532 14 10-43	Guard, Tuv. Idler (94)			
60	532 19 72-61	Arm Brake Mower			
62	872 11 06-16	Bolt Rdhd. Sqnk. 3/8-16 unc x 2			
63	532 19 94-77	Arm Brake Mower			
64	532 19 97-90	Linkage Brake			

NOTE: All component dimensions given in U.S. inches
1 inch = 25.4 mm

TRACTOR - - MODEL NO. M185-107T (96041037800), PRODUCT NO. 960 41 03-78
MOWER LIFT 45

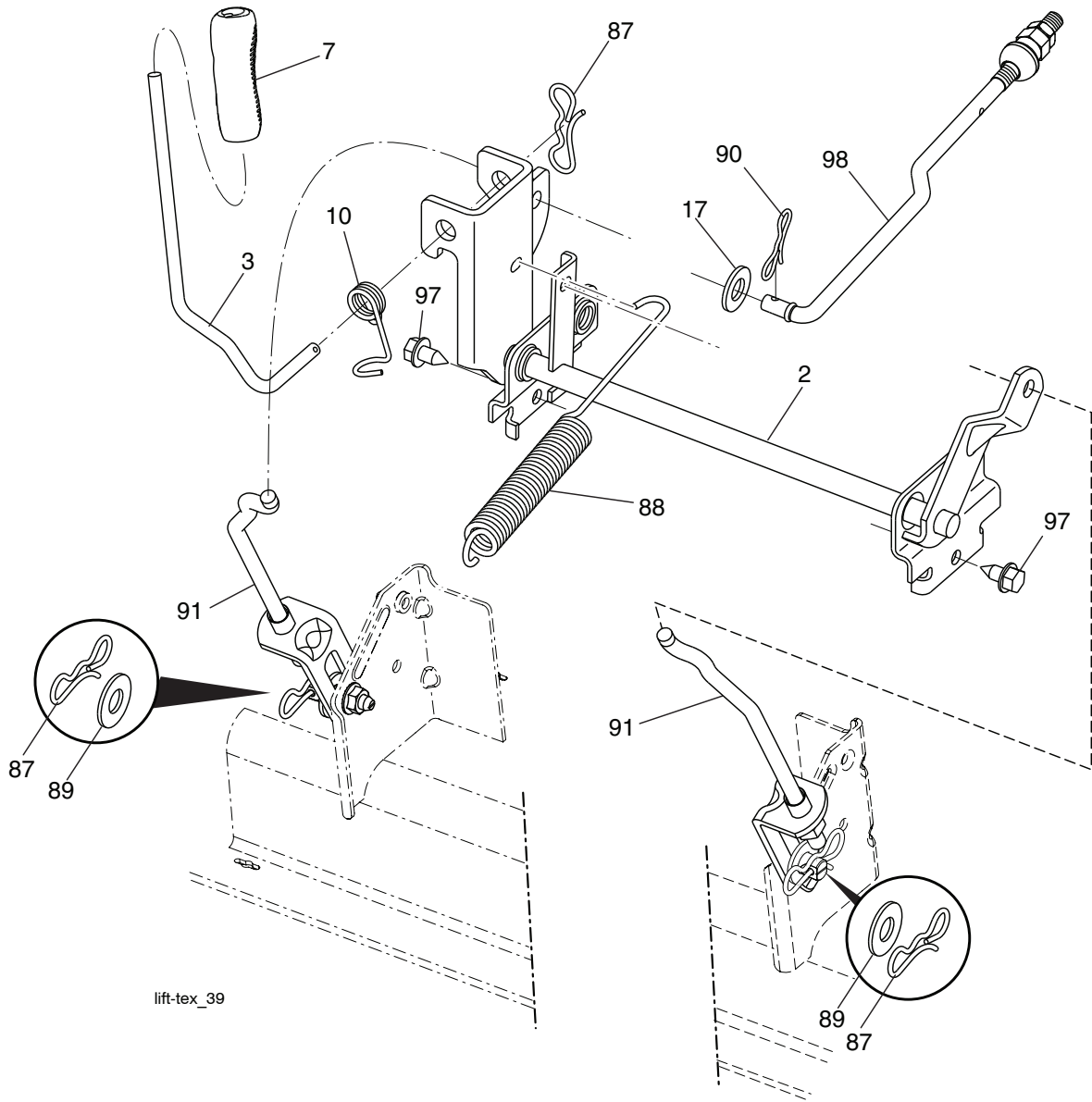

KEY NO.	PART NO.	DESCRIPTION
2	532 42 20-27	Shaft Asm., Lift
3	532 19 52-31	Lever Asm., Lift RH
7	580 96 23-01	Grip, Lever
10	532 19 63-14	Spring Torsion
17	819 13 13-12	Washer 13/32 x 13/16 x 12 Ga.
87	532 19 42-09	Pin Cotter 7/16 Bow Tie Lock
88	532 41 07-10	Spring Lift Assist
89	819 19 19-12	Washer 17/32 x 1-3/16 x 12 Ga.

KEY NO.	PART NO.	DESCRIPTION
90	532 19 42-08	Pin Cotter 5/16 Bow Tie Lock
91	532 19 79-84	Link Lift Susp Mower Rear
97	817 00 06-12	Screw 3/8-16 x .75
98	532 42 05-25	Link Lift Susp. Front Mower

NOTE: All component dimensions given in U.S. inches
 1 inch = 25.4 mm

**TRACTOR - - MODEL NO. M185-107T (96041037800), PRODUCT NO. 960 41 03-78
SEAT ASSEMBLY 42**

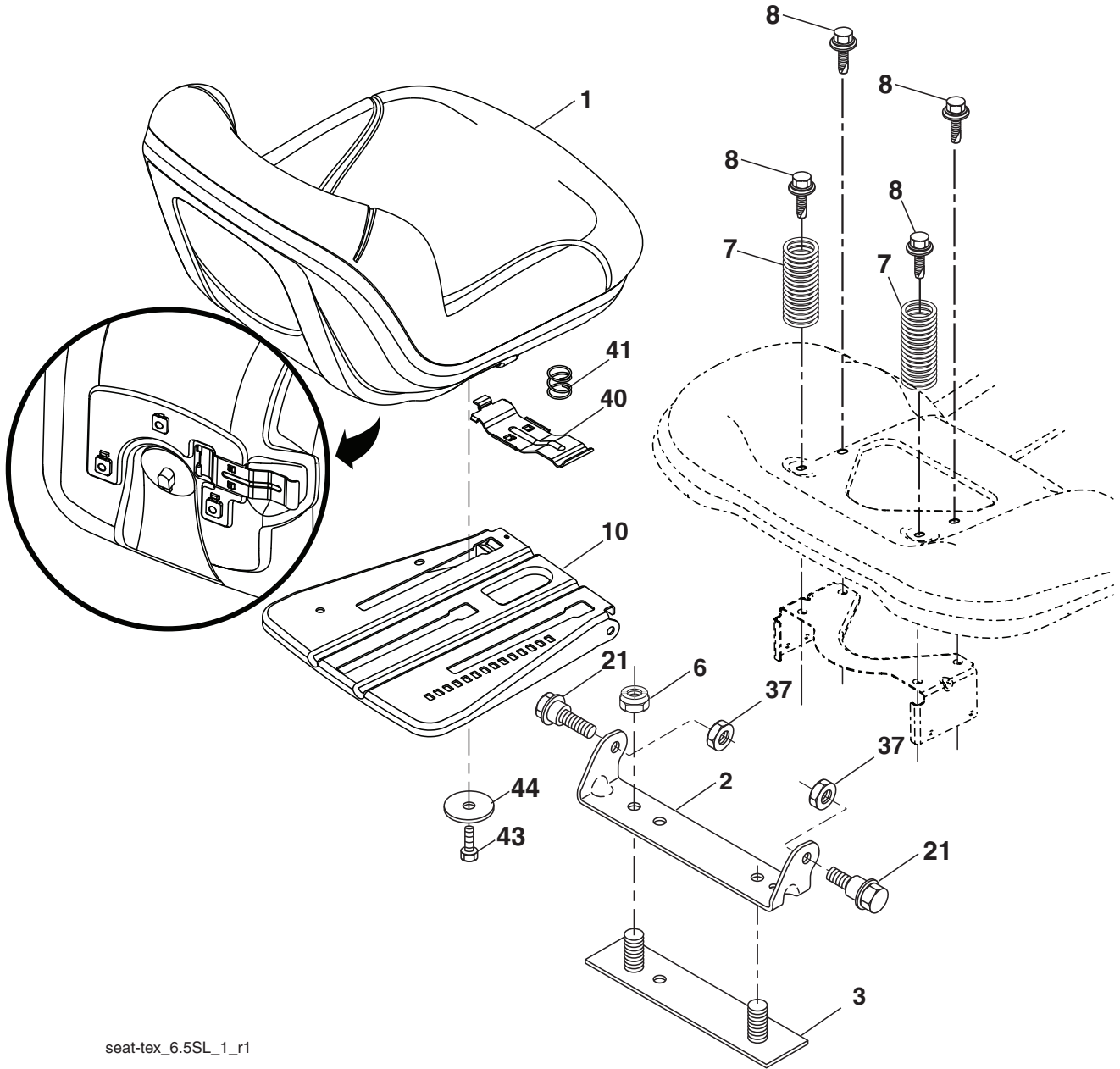

seat-tex_6.5SL_1_r1

KEY NO.	PART NO.	DESCRIPTION
1	581 46 22-01	Seat
2	532 18 01-66	Bracket Pivot Fender
3	532 14 06-75	Strap, Asm Fender
6	873 80 06-00	Nut, Lock w/Ins. 3/8-16 unc
7	532 12 41-81	Spring, Seat Cprsn
8	532 17 18-77	Bolt 5/16-18 unc x 3/4 w/Sems
10	532 19 69-77	Pan, Seat
21	532 17 18-52	Bolt, Shoulder 5/16-18

KEY NO.	PART NO.	DESCRIPTION
37	873 80 05-00	Nut, Lock 5/16-18 unc
40	532 19 76-61	Handle Slide Seat
41	532 19 82-00	Spring Latch Seat
43	874 76 06-12	Bolt 3/8-16 x 3/4
44	819 13 38-12	Washer 13/32 x 2-3/8 x 12 Ga.

NOTE: All component dimensions given in U.S. inches
1 inch = 25.4 mm

