

ILLUSTRATED PARTS LIST

MFG. ID NO. 96051006303

CUSTOMER CATALOG NO. M145-97TC

PRODUCT NO. 960 51 00-63

**TRACTOR - MODEL NO. M145-97TC (96051006303), PROD. NO. 960 51 00-63
DECALS 27**

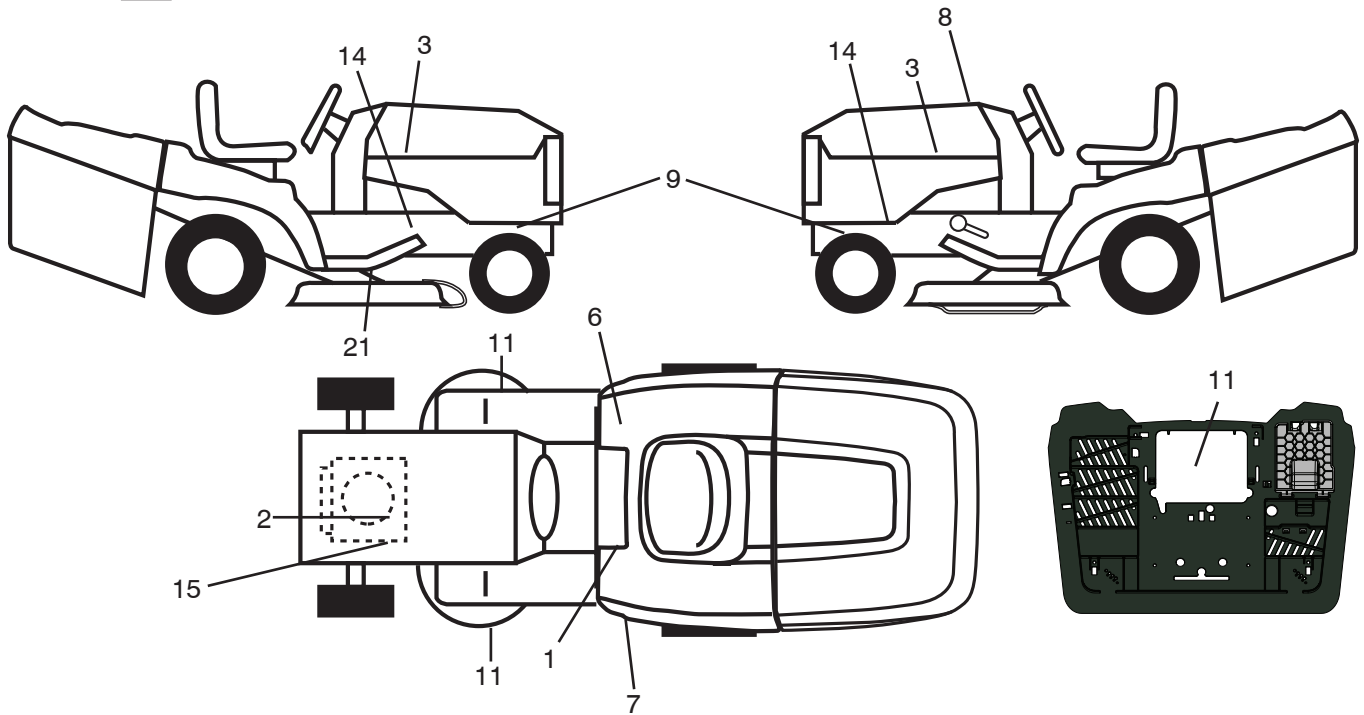

KEY NO.	PART NO.	DESCRIPTION
1	581 57 83-01	Decal, Warning
2	581 57 97-01	Decal, Warning Eng. Sym.
3	581 09 12-01	Decal, Hood RH/LH
6	581 72 41-01	Decal, 100 DB/CE
7	581 90 95-01	Decal, Fender
8	584 22 06-01	Decal, Replacement
9	581 57 98-01	Decal, Warning
11	581 57 91-01	Decal, Mower Cut Finger Symbol
14	581 57 96-01	Decal, Chassis Hot Muffler
15	532 43 74-12	Decal, Engine HP

KEY NO.	PART NO.	DESCRIPTION
21	532 44 11-89	Decal, Belt Sch CRD
--	532 18 04-35	Decal, Backplate Symb.
--	532 44 27-44	Decal, Battery
--	581 72 48-01	Decal, Bypass
--	532 42 59-86	Pad Footrest RH
--	532 42 59-76	Pad Footrest LH
--	587 20 80-40	Manual Operator's (Euro)
--	587 20 80-50	Manual Operator's (Scan)
--	587 20 80-20	Manual Operator's (E-Bloc)
--	587 20 80-30	Manual Operator's (Baltic)

WHEELS & TIRES

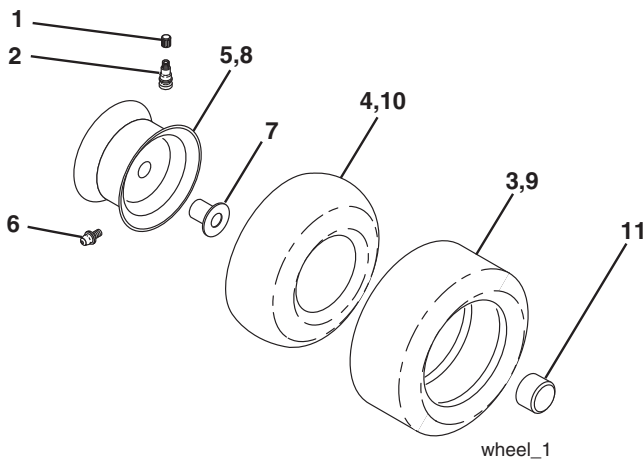

KEY NO.	PART NO.	DESCRIPTION
1	532 05 91-92	Cap Valve Tire
2	532 06 51-39	Stem Valve
3	532 10 62-22	Tire Front 15 x 6-6
4	532 05 99-04	Tube Inner Front #35060
5	532 12 51-21	Rim Asm 6" Front Service
6	532 12 49-57	Fitting Grease
7	532 12 49-59	Bearing Flange
8	532 12 51-22	Rim Asm 8" Rear Service
9	532 12 46-35	Tire Rear 18 x 8.5-8
10	532 12 49-26	Tube Rear 9 5 x 8 Service
11	532 19 32-68	Cap Axle
--	532 14 43-34	Sealant, Tire (10 oz. Tube)

NOTE: All component dimensions given in U.S. inches
1 inch = 25.4 mm

TRACTOR - MODEL NO. M145-97TC (96051006303), PROD. NO. 960 51 00-63

SCHEMATIC **38**

SCH17

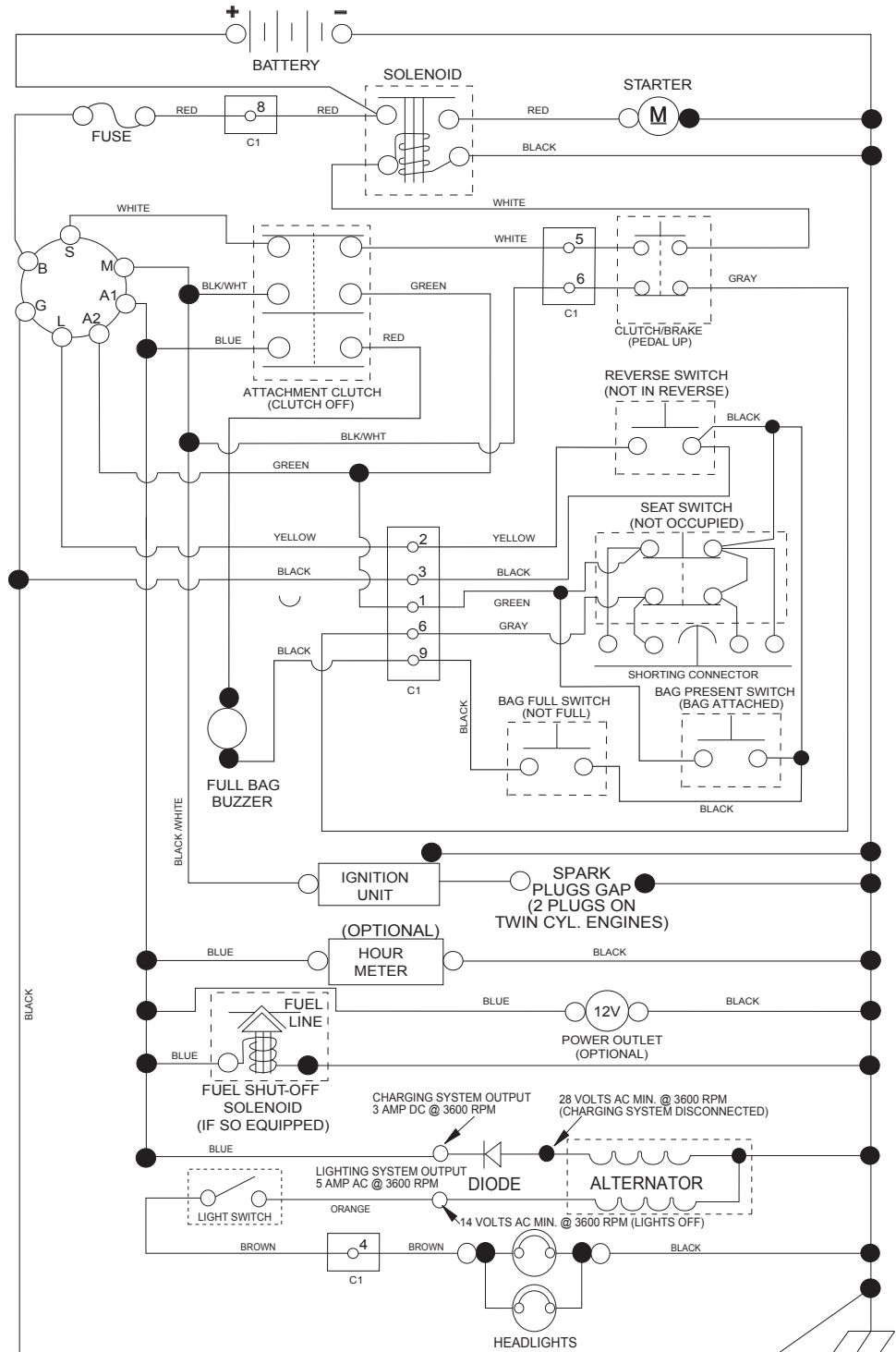

NOTE
YOUR TRACTOR IS EQUIPPED WITH A SPECIAL ALTERNATOR SYSTEM. THE LIGHTS ARE NOT CONNECTED TO THE BATTERY, BUT HAVE THEIR OWN ELECTRICAL SOURCE. BECAUSE OF THIS, THE BRIGHTNESS OF THE LIGHTS WILL CHANGE WITH ENGINE SPEED. AT IDLE THE LIGHTS WILL DIM. AS THE ENGINE SPEED IS INCREASED, THE LIGHTS WILL BECOME THEIR BRIGHTEST.



IGNITION SWITCH

POSITION	CIRCUIT	"MAKE"
OFF	M+G+A1	
RUN/OVERRIDE	B+A1	
RUN	B+A1	L+A2
START	B + S + A1	



CHASSIS HARNESS CONNECTOR (C1) (MATING SIDE)



DASH HARNESS CONNECTOR (C1) (MATING SIDE)

WIRING INSULATED CLIPS
NOTE: IF WIRING INSULATED CLIPS WERE REMOVED FOR SERVICING OF UNIT, THEY SHOULD BE RE-INSTALLED TO PROPERLY SECURE YOUR WIRING.

NON-REMOVABLE CONNECTIONS
REMOVABLE CONNECTIONS

TRACTOR - MODEL NO. M145-97TC (96051006303), PROD. NO. 960 51 00-63
ELECTRICAL 32

TC03S

With Service Minder Option

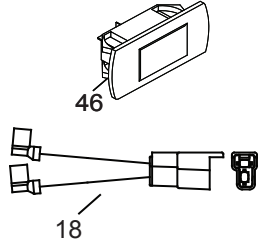

With Charge Indicator Option

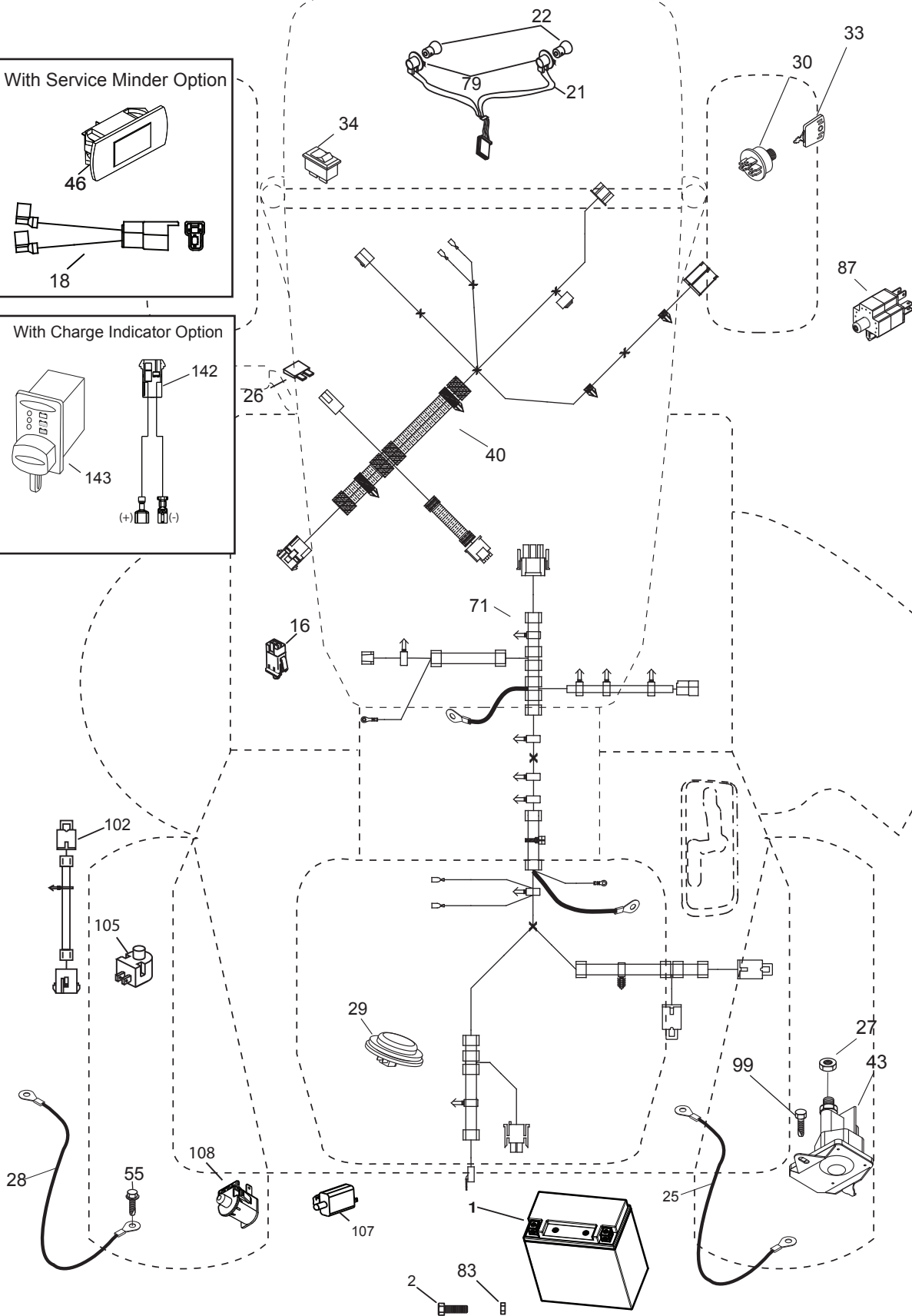
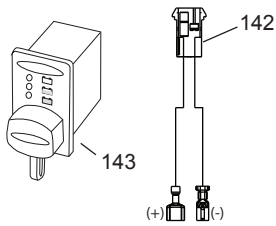

**TRACTOR - MODEL NO. M145-97TC (96051006303), PROD. NO. 960 51 00-63
ELECTRICAL 32**

KEY NO.	PART NO.	DESCRIPTION
1	532 43 71-57	Battery
2	532 44 09-23	Screw Hex Hd Cap M6 x 1.12mm
16	532 17 61-38	Switch Interlock
21	532 40 02-52	Harness Asm Light w/4152J
22	532 00 41-52	Bulb Light #1156
25	581 48 98-01	Cable Battery Red
26	532 17 51-58	Fuse
27	873 51 04-00	Nut Keps Hex 1/4-20 unc
28	581 48 98-02	Cable Ground Black
29	532 40 15-45	Switch Seat
30	532 19 33-50	Switch Ignition
33	532 41 19-35	Key/Chain
34	532 11 07-12	Switch Light
40	532 42 10-02	Harness Ignition Dash
43	532 19 25-07	Solenoid
55	817 06 05-12	Screw 5/16-18 x 3/4
71	532 44 08-20	Harness Chassis
79	532 17 52-42	Socket Asm.
83	532 43 67-74	Nut Square M6 x 1 x 8.5 x 11mm
87	532 42 10-60	Switch Railmount
99	817 00 05-12	Screw 5/16-18 x 3/4
102	532 44 12-62	Harness Pigtail
105	532 40 75-68	Switch Reverse
107	532 18 03-79	Switch Full Bagger Indicator
108	532 42 10-62	Switch Snapmount

NOTE: All component dimensions given in U.S. inches
1 inch = 25.4 mm

TRACTOR - MODEL NO. M145-97TC (96051006303), PROD. NO. 960 51 00-63
CHASSIS AND ENCLOSURES **39**

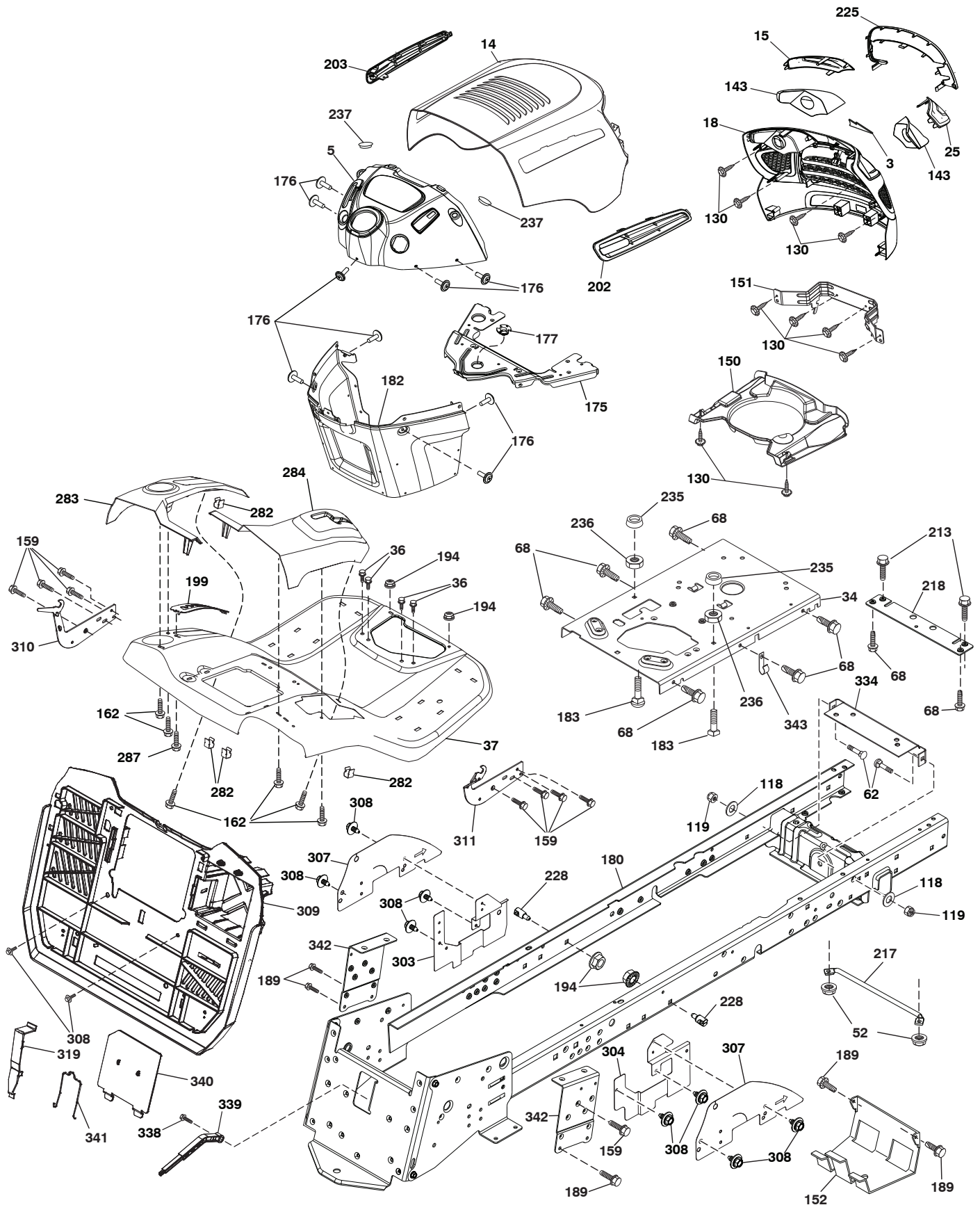

chassis-tex crd_TEX LT PRED_15

**TRACTOR - MODEL NO. M145-97TC (96051006303), PROD. NO. 960 51 00-63
CHASSIS AND ENCLOSURES 39**

KEY NO.	PART NO.	DESCRIPTION	KEY NO.	PART NO.	DESCRIPTION
3	578 89 71-01	Emblem Mount	203	581 56 48-01	Vent Hood LH
5	532 40 95-97	Dash	213	874 76 05-12	Bolt 5/16-18 x 3/4
14	581 56 47-01	Hood	217	532 40 91-67	Rod Pivot Hood
15	581 05 58-01	Lens LH	218	532 19 63-95	X-Piece Hood Stop
18	581 05 57-01	Grille	225	581 05 62-01	Trim Ring
25	581 05 59-01	Lens RH	228	532 19 51-61	Stud Fastener
34	580 91 09-01	Plate Engine	235	532 40 61-29	Spacer Fender
36	817 06 05-12	Screw 5/16-18 x 3/4	236	873 93 05-00	Nut Lock 5/16-18 unc
37	532 44 08-49	Fender	237	532 40 37-04	Plug Mount Cargo
52	873 68 05-00	Nut Crown Lock 5/16	282	532 41 41-10	Clip Retainer
62	872 11 06-08	Bolt 3/8-16 x 1 Gr. 5	283	532 44 03-61	Console Deck Lift
68	817 49 05-08	Screw Thdrol. 5/16-18 x 1/2	284	532 44 03-60	Console Shift RH
118	819 13 13-16	Washer 13/32 x 13/16 x 16 Ga.	287	817 60 04-06	Screw Hex Washhead 1/4-20 x 3/8
119	873 68 06-00	Nut 3/8-16 unc	303	587 49 31-01	Shield LH
130	532 41 63-58	Screw #10 x 0.750 BOS Thread	304	587 49 33-01	Shield RH
143	581 05 60-02	Insert Reflective LH/RH	307	587 49 45-01	Shield Upper
150	532 40 02-67	Duct, Air	308	532 17 18-77	Bolt 5/16-18 unc x 3/4
151	532 18 75-68	Bracket Pivot Hood	309	584 44 11-01	Backplate Bagger
152	532 19 95-35	Shield Browning	310	532 44 66-36	LH Adjust Hanger
159	817 00 06-12	Screw Hexwsh Thdr 3/8-16 x 3/4	311	532 44 66-37	RH Adjust Hanger
162	532 14 24-32	Screw Hex Wsh. Hi-Lo 1/4 x 1/2 unc	319	532 17 46-62	Lever Bagger
175	532 19 94-72	Crossmember	334	532 44 25-37	Engine Plate
176	532 40 07-76	Screw 10-24 x 5/8	338	532 43 66-40	Bolt Shoulder
177	532 19 52-28	Bushing Steering	339	532 43 66-41	Lever Bagger Full
180	581 18 71-01	Chassis	340	532 44 09-31	Door Battery
182	532 40 71-76	Dash Lower	341	532 43 66-38	Latch Battery Door
183	874 52 05-20	Bolt 5/16-18 x 1-1/4	342	532 43 59-38	Support Fender
189	817 00 05-12	Screw 5/16-18 x 3/4	343	532 44 07-49	Clip
194	873 90 05-00	Nut Lock Hex Flange 5/16-18			
199	532 41 87-39	Plate Deck Lift			
202	581 56 49-01	Vent Hood RH			

NOTE: All component dimensions given in U.S. inches
1 inch = 25.4 mm

**TRACTOR - MODEL NO. M145-97TC (96051006303), PROD. NO. 960 51 00-63
DRIVE **40****

KEY NO.	PART NO.	DESCRIPTION	KEY NO.	PART NO.	DESCRIPTION
1	---	Transaxle, TUFFTORQ K46 DF (446488) (Order parts from trans-axle manufacturer.)	189	532 43 36-11	Bellcrank Ground Drive
2	532 12 35-83	Key Square	195	580 45 69-01	Bracket Brake Rod
6	532 12 40-28	Bushing Snap	203	819 11 11-16	Washer 11/32 x 11/16 x 16 Ga.
15	819 13 13-16	Washer 13/32 x 13/16 x 16 Ga.	205	532 12 17-48	Washer 25/32 x 1-5/8 16 Ga.
17	532 43 62-27	Spring, Brake	210	532 40 09-80	Rocker Asm. Pedal
29	532 43 58-81	Rod, Brake	214	532 42 12-63	Pedal Forward
30	819 13 16-16	Washer 13/32 x 1 x 16 Ga.	215	532 41 94-82	Pad Pedal Reverse
33	812 00 00-01	Ring E	211	532 12 01-83	Bearing Nylon
35	532 40 10-31	Rod, Brake, Park	221	532 40 31-87	Retainer Spring
37	532 18 89-67	Washer .793 x 1.637 x 060	222	879 21 20-10	Washer Flat
38	532 16 96-13	Nylon Snap In	226	532 40 15-64	Bracket Mount Torque
42	532 12 48-72	Cover, Foot Pedal	227	817 49 05-12	Screw
49	872 11 06-14	Bolt 3/8-16 unc	263	817 00 06-12	Screw Hexwsh Thdr. 3/8-16 x 3/4
50	532 19 43-27	Idler Flat	268	532 18 24-02	Guard Muffler
51	873 90 06-00	Lock Nut 3/8-16	275	819 13 16-14	Washer 13/32 x 1 x 14 Ga.
52	532 19 43-26	Idler V Groove	279	532 44 42-83	Link Shift Hydro
56	532 44 18-34	V-Belt, Drive	280	819 11 10-12	Washer 11/32 x 5/8 x 12 Ga.
61	532 43 77-88	Pulley Transaxle	309	532 16 55-81	Plate Fstnr.
64	532 19 78-65	Shaft Asm. Pedal Brake Control	311	532 16 98-45	Washer Nylon
73	874 49 05-56	Bolt Hex 5/16-18 x 3.75	312	532 16 56-14	Hub Tapered
90	532 44 36-05	Keeper Belt Clutching	313	874 78 04-16	Bolt Hex Fin 1/4-20 unc x 1.GD5
99	532 44 39-47	Rod Bypass	314	532 44 47-13	Retainer, Belt
103	873 35 05-00	Nut 5/16-18 unc	315	817 58 05-20	Screw Thdrol 5/16-18 x 4.25
116	873 90 05-00	Nut Lock Hex Flange 5/16-18	319	532 43 67-94	Spacer Transaxle Tex CRD
125	817 00 05-12	Screw 5/16-18 x 3/4	320	532 18 76-90	Washer Spacer
140	810 04 04-00	Washer Lock Hvy. Helical 1/4	335	532 19 95-34	Idler V Pulley
143	817 49 05-08	Screw Thdrol 5/16-18 x 1/2 TYTT	339	532 43 68-67	Strap Torue K46 CRD Tex
159	876 02 04-12	Pin Cotter 1/8 x 3/4	351	532 43 69-98	Bracket Deck Sway
160	532 16 94-84	Retainer Clip	352	532 43 58-19	Bracket Idler
161	532 10 57-09	Spring, Return, Clutch	353	532 43 65-77	Bracket Idler RH
163	532 43 66-32	Rod Control	355	532 43 56-69	Strap Torque
166	532 42 91-64	Nut Push .625	360	532 44 47-14	Nut Hex 5/16-24
167	532 40 52-57	Latch Brake Parking	362	532 43 68-12	Idler Flat
175	532 42 93-59	Shaft Asm. Cross Shift	364	532 44 30-32	Bracket Idler
183	532 13 70-57	Spacer Axle			
184	532 41 14-84	Handle Park Brk.			
185	872 11 06-22	Bolt 3/8-16 unc x 2-3/4 Gr. 5			
186	532 19 43-21	Spacer Retainer			
188	532 19 43-23	Link Clutch Ground Drive			

NOTE: All component dimensions given in U.S. inches
1 inch = 25.4 mm

TRACTOR - MODEL NO. M145-97TC (96051006303), PROD. NO. 960 51 00-63
ENGINE 24

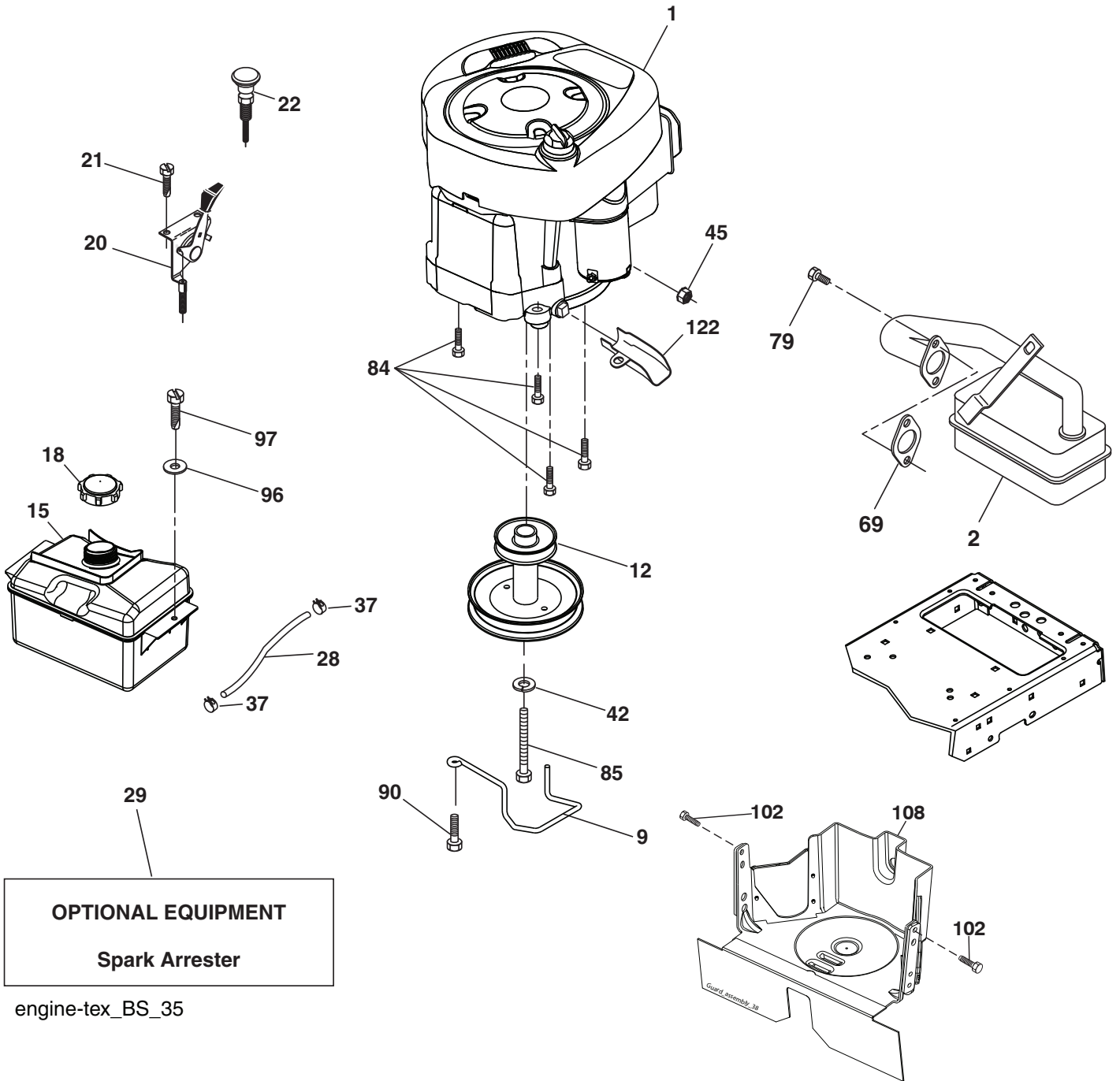

OPTIONAL EQUIPMENT
Spark Arrester

engine-tex_BS_35

**TRACTOR - MODEL NO. M145-97TC (96051006303), PROD. NO. 960 51 00-63
ENGINE 24**

KEY NO.	PART NO.	DESCRIPTION
1	— — — — —	Engine Briggs Model 31Q507-0002-H1 (585579801) (Order parts from engine manufacturer.)
2	532 13 73-52	Muffler
9	584 90 80-01	Keeper Belt Engine
12	532 40 54-71	Pulley Engine
15	581 28 99-01	Tank Fuel
18	532 43 02-20	Cap Fuel
20	532 18 38-97	Control Throttle/Choke
21	532 41 63-58	Screw #10 x 0.750
22	532 19 49-81	Control Choke
28	532 13 70-40	Line Fuel
29	532 13 71-80	Kit Spark Arrester (Flat Scrn)
37	532 12 34-87	Clamp Hose Blk
42	810 04 07-00	Washer Lock 7/16
45	873 51-04-00	Nut Keps Hex 1/4-20 unc
69	532 16 52-91	Gasket Muffler
79	532 19 23-34	Screw 5/16-18 x .75
84	817 06 06-20	Screw 3/8-16 x 1-1/4
85	532 17 39-37	Bolt 7/16-20 x 4 x Gr. 5-1.5 THR
90	817 00 06-16	Screw 3/8-16 x 1
96	819 09 14-16	Washer 9/32 x 7/8 x 16 Ga.
97	817 67 04-12	Screw Hexwsh Thdrol 1/4-20 x 3/4
102	817 06 05-16	Screw
108	532 42 30-41	Cover Pulley Engine
122	532 42 19-22	Extension Drain Oil

NOTE: All component dimensions given in U.S. inches
1 inch = 25.4 mm

Engine Power Rating Information

The gross power rating for individual gas engine models is labeled in accordance with SAE (Society of Automotive Engineers) code J1940 (Small Engine Power & Torque Rating Procedure), and rating performance has been obtained and corrected in accordance with SAE J1995 (Revision 2002-05). Torque values are derived at 3060 RPM; horsepower values are derived at 3600 RPM. Actual gross engine power will be lower and is affected by, among other things, ambient operating conditions and engine-to-engine variability. Given both the wide array of products on which engines are placed and the variety of environmental issues applicable to operating the equipment, the gas engine will not develop the rated gross power when used in a given piece of power equipment (actual “on-site” or net power). This difference is due to a variety of factors including, but not limited to, accessories (air cleaner, exhaust, charging, cooling, carburetor, fuel pump, etc.), application limitations, ambient operating conditions (temperature, humidity, altitude), and engine-to-engine variability. Due to manufacturing and capacity limitations, Briggs & Stratton may substitute an engine of higher rated power for this Series engine.

TRACTOR - MODEL NO. M145-97TC (96051006303), PROD. NO. 960 51 00-63
STEERING ASSEMBLY **41**

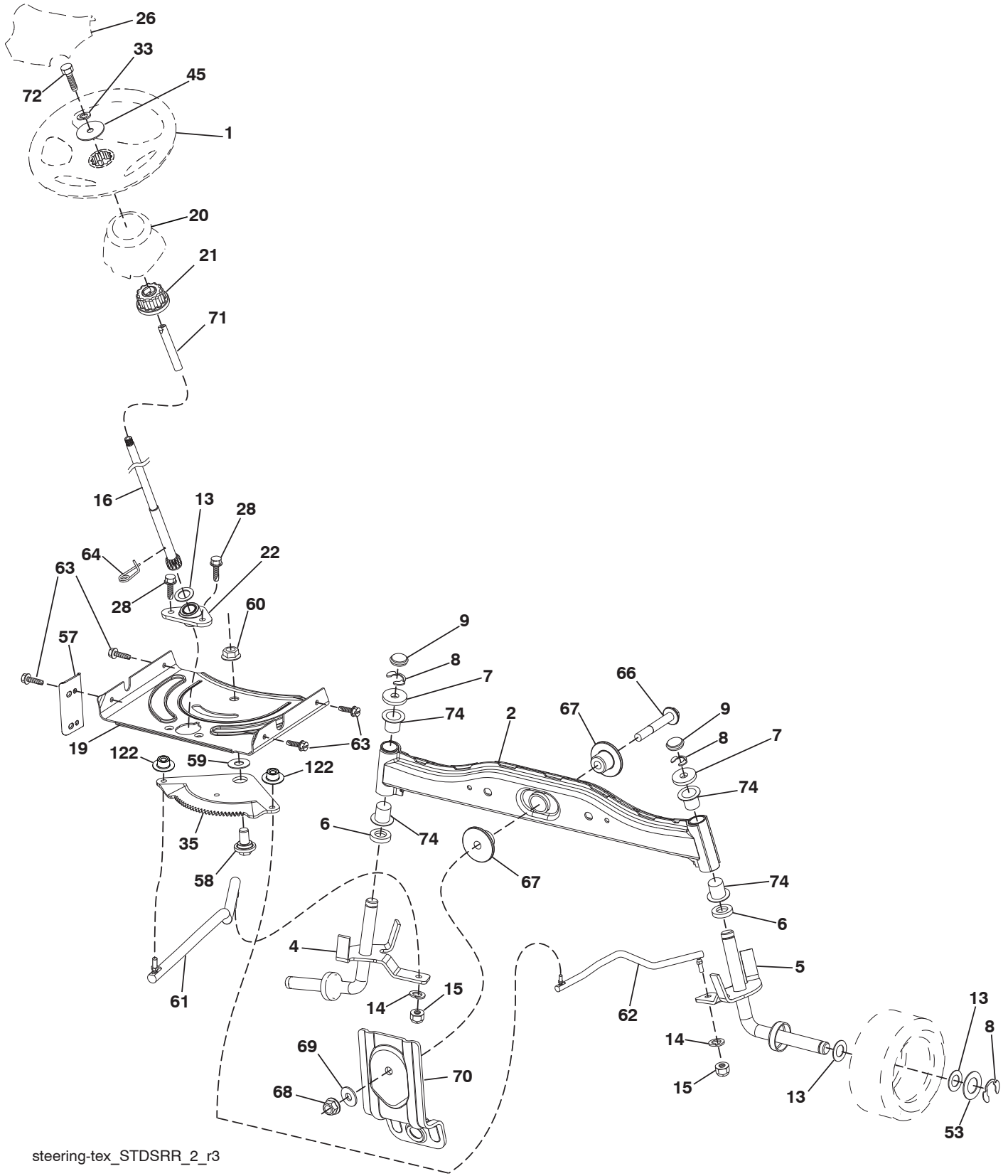

steering-tex_STDSRR_2_r3

**TRACTOR - MODEL NO. M145-97TC (96051006303), PROD. NO. 960 51 00-63
STEERING ASSEMBLY 41**

KEY NO.	PART NO.	DESCRIPTION
1	532 44 28-04	Wheel, Steering
2	532 41 81-68	Axle Asm., Front
4	532 40 30-87	Spindle Asm., LH
5	532 40 30-88	Spindle Asm., RH
6	532 12 49-31	Bearing, Race Thrust Harden
7	532 12 17-48	Washer 25/32 x 1-5/8 x 16 Ga.
8	812 00 00-29	Ring, Klip #T5304-75
9	532 12 12-32	Cap, Spindle
13	532 12 17-49	Washer 25/32 x 1-1/4 x 16 Ga.
14	810 04 06-00	Washer, Lock Hvy Hlcl Spr 3/8
15	873 54 06-00	Nut, Crown Lock 3/8-24 unf
16	532 42 93-73	Shaft Steering
19	532 19 47-29	Plate Steering
20	532 40 97-63	Boot, Steering
21	532 18 67-37	Adapter, Wheel Steering
22	532 42 05-37	Strg. Supt. Lower
26	532 44 77-59	Insert, Wheel Steering
28	817 00 06-12	Screw 3/8-16 x 3/4
33	810 04 05-00	Washer Lock 5/16
35	532 19 47-32	Gear, Sector Plate
45	819 11 38-12	Washer 11/32 x 3/8 x 12 Ga.
53	532 18 89-67	Washer Hardened .793 x 1.637 x .060
57	532 40 74-65	Bracket Upstop
58	532 19 47-47	Bolt Shoulder Sector Pivot CFM
59	532 19 47-48	Washer Thrust Sector Steering
60	873 97 10-00	Nut Flange Lock 5/8-11
61	532 19 47-40	Draglink, LH
62	532 19 47-41	Draglink, RH
63	817 00 05-12	Screw 5/16-18 x 3/4
64	532 19 98-49	Retainer Clip Spring Steering
66	871 02 07-48	Bolt Hex Fghd 7/16-14 x 3 Serr
67	532 19 47-37	Bushing PM Front Axle
68	873 90 07-00	Nut Lock Flange 7/16-14 Gr. 5
69	532 19 91-62	Washer 1.5 x .505 x .118
70	585 33 88-01	Bracket Deck Susp. Front
71	532 19 07-52	Shaft Extension Steering
72	532 42 89-82	Bolt Fin Hx 5/16-18 x 4
74	532 12 49-37	Bearing
122	532 44 49-62	Cap Gear Sector

NOTE: All component dimensions given in U.S. inches
1 inch = 25.4 mm

TRACTOR - MODEL NO. M145-97TC (96051006303), PROD. NO. 960 51 00-63
MOWER DECK 44

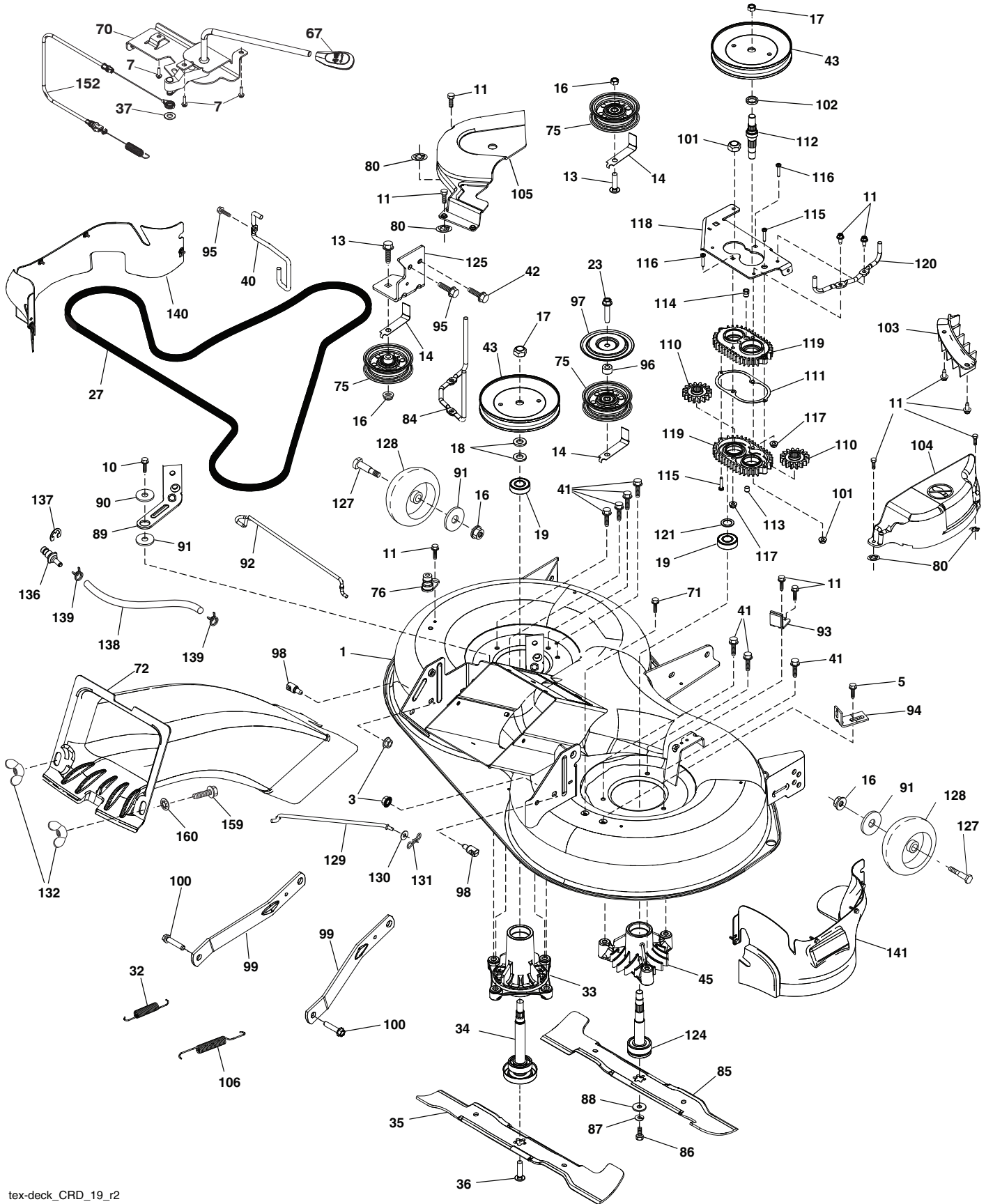

tex-deck_CRD_19_r2

TRACTOR - MODEL NO. M145-97TC (96051006303), PROD. NO. 960 51 00-63
MOWER DECK 44

KEY NO.	PART NO.	DESCRIPTION	KEY NO.	PART NO.	DESCRIPTION
1	532 43 69-70	Deck Weldment	100	532 19 65-39	Bolt Shoulder
3	873 90 05-00	Nut Lock Hex Flange 5/16 - 18	101	873 68 09-00	Nut Crownlock 9/16 - 18 unc
5	817 00 05-10	Bolt 5/16-18	102	532 40 25-11	Spacer Bearing Swing Plate
7	532 41 63-58	Screw #10 x 0.750 BOS Thread	103	532 43 69-92	Guard Front Vent
11	532 13 77-29	Screw Thd Roll 1/4 - 20 X 5/8	104	532 43 89-68	Mandrel Cover RH
13	872 11 06-12	Bolt Carr Sh 3/8 - 16 X 1-1/2 Gr. 5	105	532 43 87-44	Mandrel Cover LH
14	532 15 60-85	Keeper Belt Idler	106	532 19 32-16	Spring Brake Return
16	873 90 06-00	Nut Lock FIG 3/8 - 16 unc	110	532 41 53-56	Gear Output
17	532 40 02-34	Nut Flange Lock Top	111	532 43 69-79	Gasket Gearcase
18	532 18 76-90	Washer Spacer Mandrel	112	532 44 38-52	Shaft Gearcase Adapter
19	532 11 04-85	Bearing Ball Mandrel	113	532 43 85-33	Plug Oil
23	817 49 06-28	Screw Thdroi 3/8 - 16 X 1-3/4	114	532 43 85-34	Valve Relief
10	817 00 06-16	Screw 3/8-16x1 smgml tap	115	818 03 10-16	Screw Torx #10-24 x 1
27	532 43 97-26	V-Belt Drive	116	872 11 04-14	Bolt 1/4-20 x 1.75 Gr. 5
32	532 40 18-72	Spring Return Deck	117	873 90 04-00	Nut Hex Flange 1/4-20 unc
33	532 18 72-81	Housing Mandrel 4pt Service	118	532 43 69-89	Arm Clutching
34	532 19 28-72	Shaft Asm Mndrl N/Greaseable38	119	532 43 81-66	Gearcase Subasm
35	532 42 79-84	Blade Mower LH	120	532 43 69-91	Keeper Belt RH
36	532 19 30-03	Bolt/Washer Asm 7/16 - 20 unf	121	532 43 69-85	Washer
37	819 13 13-16	Washer 13/32 x 13/16 x 16 Ga.	124	532 43 69-86	Non Greasable Mandrel Shaft
40	532 19 72-58	Keeper Belt Engine LH	125	532 44 04-20	Bracket Idler Chassis
41	584 95 39-01	Bolt Hex Wsh Hd .313-18 x 1.19	127	532 19 34-06	Bolt Shoulder 3/8-16 x 3-5/8 Gr. 5
42	817 00 05-12	Screw 5/16-18 x 3/4	128	532 17 48-73	Wheel Gauge
43	532 19 74-73	Pulley Mandrel	129	532 40 48-51	Rod Anti-Sway
45	532 13 71-52	Housing Mandrel	130	819 13 13-12	Washer 13/32 x 13/16 x 12 Ga.
67	532 40 30-12	Handle Clutch Cable	131	532 19 42-08	Pin Cotter 5/16 Bow Tie Lock
70	532 40 12-46	Clutch Asm Manual LT Pred	132	532 17 88-99	Knob
71	817 67 06-08	Screw 3/8-16 x 1/2	136	532 43 96-39	Washout Port
72	532 44 68-10	Chute Upper	137	812 00 00-29	Ring Clip
75	532 13 14-94	Pulley Idler Flat	138	532 44 07-43	Hose
76	532 43 96-40	Washout Port	139	532 44 07-42	Hose Clamp
80	532 42 30-62	Pal Nut 1/4	140	532 44 86-32	LH Guard
84	532 43 25-20	Keeper Belt LH Mandrel	141	532 44 85-29	RH Guard
85	532 42 79-85	Blade Mower RH	152	532 44 04-88	Cable Clutch Manual w/Spring
86	532 18 17-13	Bolt 3/8-24 x 1.50 Gr. 8	159	872 14 06-14	Bolt 3/8-16 unc x 1-3/4
87	810 03 06-00	Washer Lock Hvy. 3/8	160	532 16 89-37	Nut Push
88	532 14 02-96	Washer Hard	--	532 19 28-70	Mandrel Assembly (Includes Housing Assembly (key#33), Shaft Assembly (key#34) and Bearing Only (key#19) - Pulley/ Nut/Washer And Blade Bolt/ Washers Not Included)
89	532 43 81-24	Arm Brake 97 LH	--	532 44 86-41	Replacement Mower Complete
90	532 19 90-92	Spacer Retainer			
91	819 13 20-12	Washer 13/32 x 1-1/4 x 12 Ga.			
92	532 43 69-93	Rod Brake Assembly			
93	532 43 81-25	Arm Brake RH			
94	532 19 72-50	Bracket Clutch Cable			
95	817 00 06-12	Screw 3/8-16 x 3/4			
96	532 40 02-71	Spacer			
97	532 18 20-61	Shield Idler Mower			
98	532 19 51-61	Stud Fastener			
99	532 19 51-86	Arm Suspension Mower Rear			

NOTE: All component dimensions given in U.S. inches
1 inch = 25.4 mm

TRACTOR - MODEL NO. M145-97TC (96051006303), PROD. NO. 960 51 00-63
MOWER LIFT 45

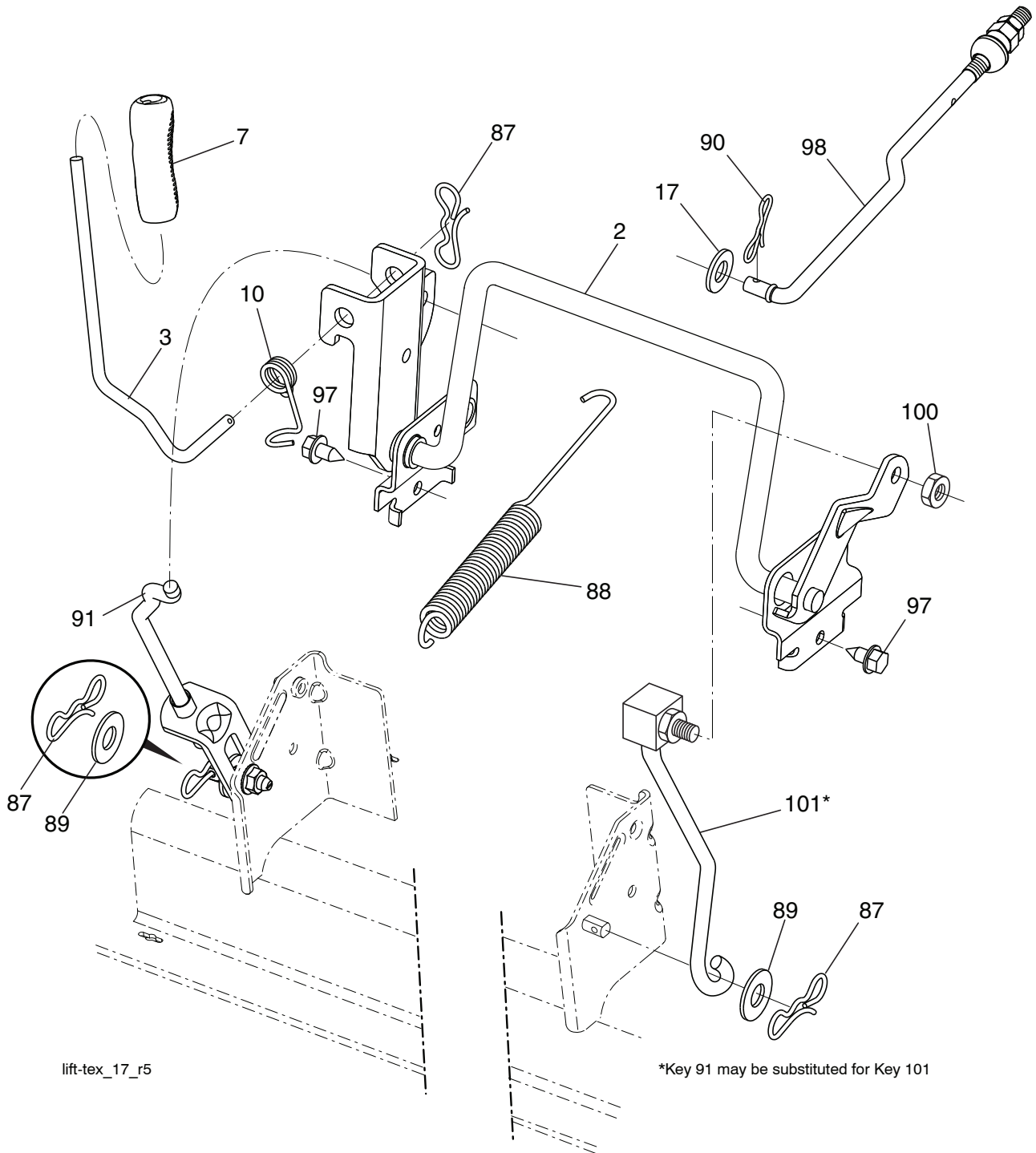

lift-tex_17_r5

*Key 91 may be substituted for Key 101

KEY NO.	PART NO.	DESCRIPTION
2	532 43 69-96	Deck Lift
3	532 19 52-31	Lever Asm., Lift RH
7	580 96 23-01	Grip, Lever
10	532 19 63-14	Spring Torsion
17	819 13 13-12	Washer 13/32 x 13/16 x 12 Ga.
87	532 19 42-09	Pin Cotter 7/16 Bow Tie Lock
88	532 43 69-95	Spring Lift Assist
89	819 19 19-12	Washer 17/32 x 1-3/16 x 12 Ga.

KEY NO.	PART NO.	DESCRIPTION
90	532 19 42-08	Pin Cotter 5/16 Bow Tie Lock
91	532 19 51-81	Link Lift Susp Mower Rear
97	817 49 06-08	Screw 3/8-16 x 1/2
98	532 19 52-70	Link Lift Susp. Front Mower
100	873 93 06-00	Nut Centerlock 3/8-16 unc
101	532 40 70-03	Link Asm. Lift Fixed

NOTE: All component dimensions given in U.S. inches
 1 inch = 25.4 mm

**TRACTOR - MODEL NO. M145-97TC (96051006303), PROD. NO. 960 51 00-63
SEAT ASSEMBLY 42**

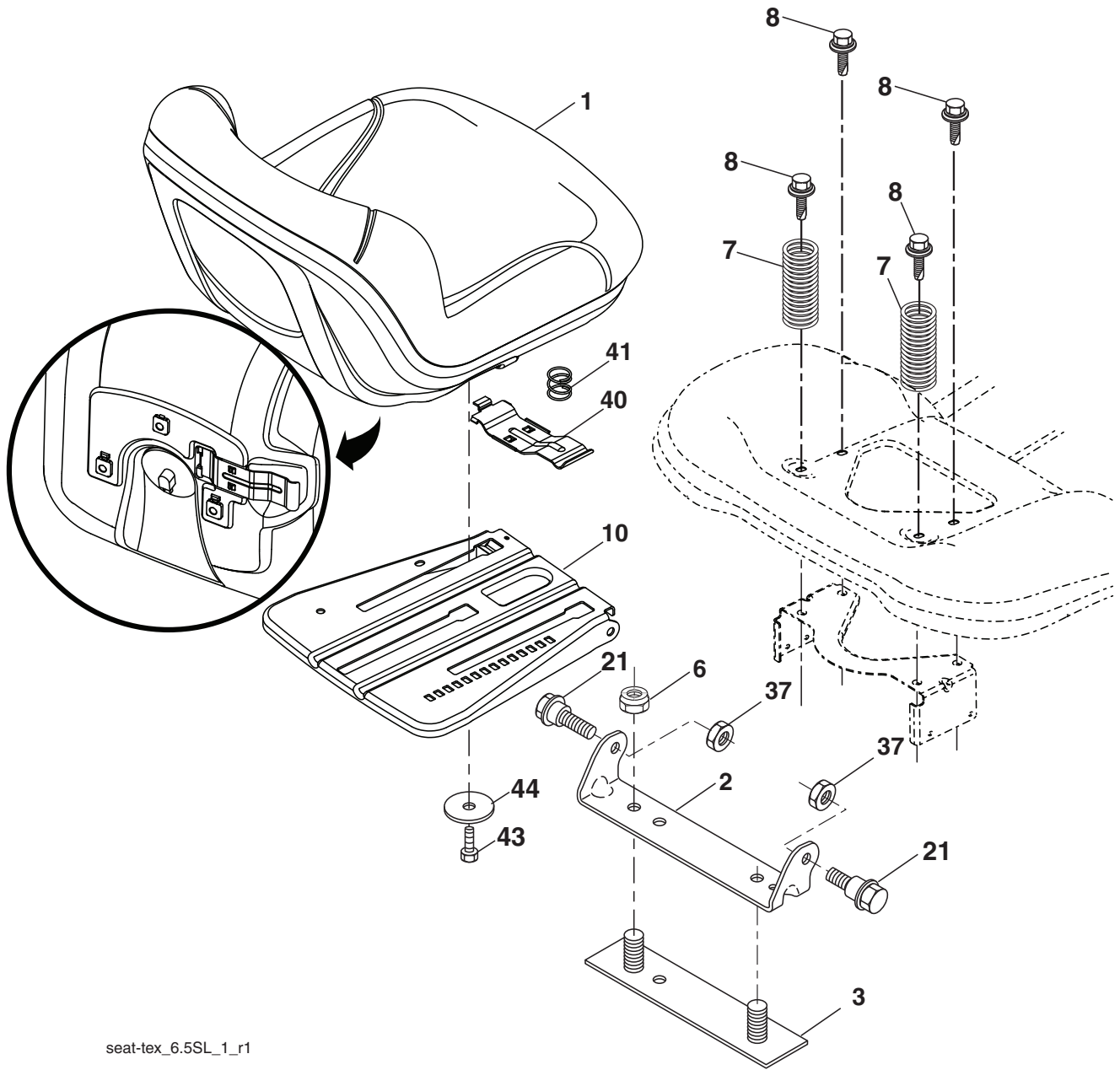

seat-tex_6.5SL_1_r1

KEY NO.	PART NO.	DESCRIPTION
1	581 46 21-01	Seat
2	532 18 01-66	Bracket Pnt Pivot Fender
3	532 14 06-75	Strap
6	873 80 06-00	Nut Lock Hex w/Ins 3/8-16
7	532 12 41-81	Spring Seat Cprsn 2 250 Blk Zi
8	532 17 18-77	Bolt 5/16-18 unc x 3/4
10	532 19 69-77	Pan Pnt Seat
21	532 17 18-52	Bolt Shoulder 5/16-18 unc-2A

KEY NO.	PART NO.	DESCRIPTION
37	873 80 05-00	Nut Hex Lock w/Ins 5/16-18
40	532 19 76-61	Handle Slide
41	532 19 82-00	Spring Latch
43	874 76 06-12	Bolt 3/8-16 unc x 3/4
44	819 13 38-12	Washer 13/32 x 2-3/8 x 12 Ga.

NOTE: All component dimensions given in U.S. inches
1 inch = 25.4 mm

TRACTOR - MODEL NO. M145-97TC (96051006303), PROD. NO. 960 51 00-63
BAGGER **46**

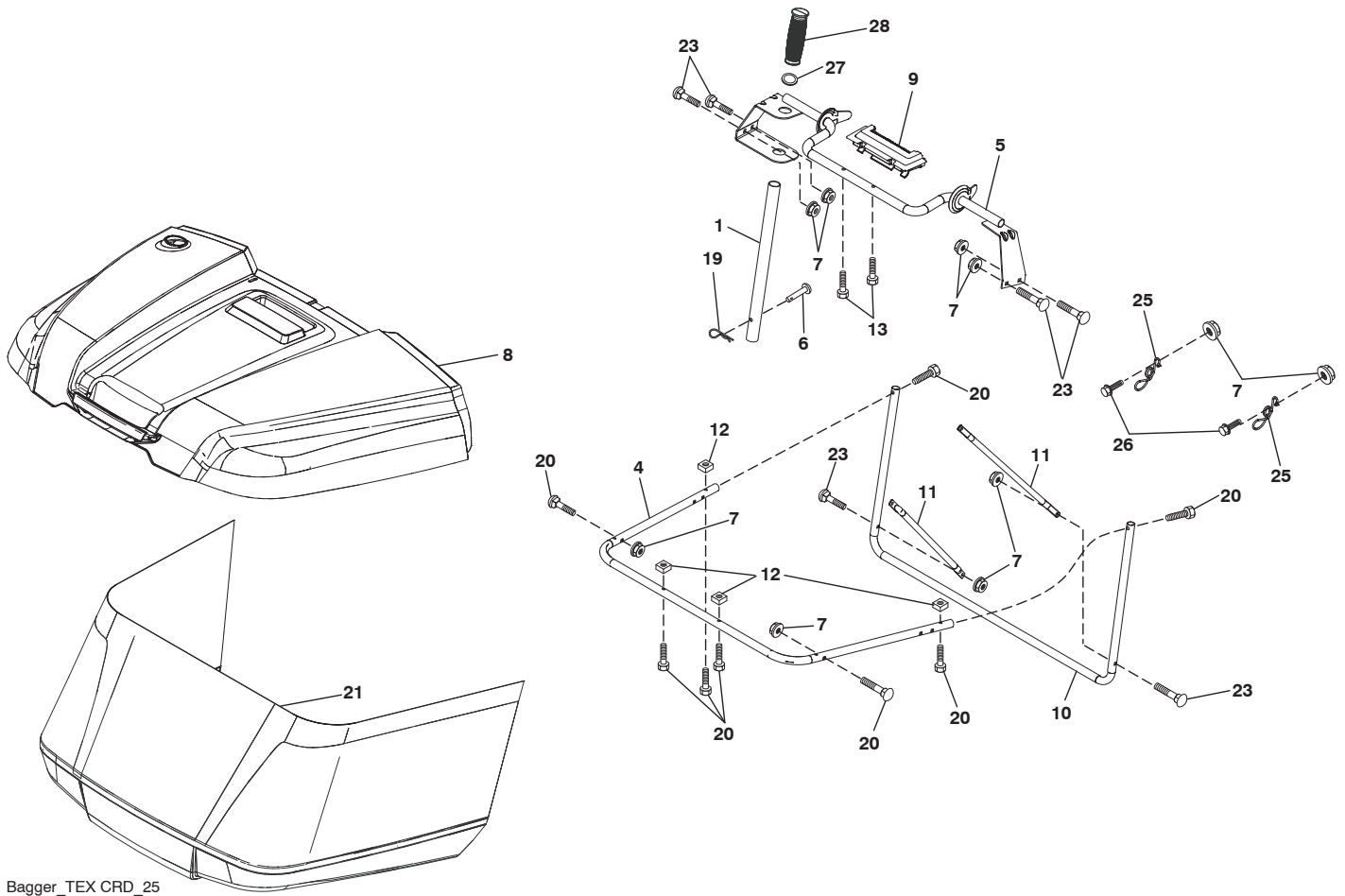

Bagger_TEX CRD_25

**TRACTOR - MODEL NO. M145-97TC (96051006303), PROD. NO. 960 51 00-63
BAGGER 46**

KEY NO.	PART NO.	DESCRIPTION
1	532 42 86-10	Tube Handle Bagger
4	532 43 96-12	Frame Asm Bagger Top
5	532 41 76-32	Frame Asm Top Bagger
6	532 12 68-75	Rivet Drilled
7	873 90 04-00	Nut Hex Flange 1/4-20 unc
8	532 42 59-54	Cover Bagger
9	532 41 76-29	Insert Handle Bagger
10	532 43 67-70	Frame Front
11	532 43 67-71	Tubing Brace Bagger
12	532 42 17-93	Nut Square 1/4
13	532 42 17-80	Screw 1/4 x 1.150
19	532 19 42-08	Cotter Pin 5/16 Bow Tie
20	585 36 88-01	Screw Hex Cap 1/4-20 x 1.375
21	581 33 70-01	Bag Asm
23	872 04 04-10	Bolt Carr. 1/4-20
25	532 42 16-14	Spring Latch
26	817 49 04-12	Screw 1/4-20
27	532 42 12-62	Grommet Rubber
28	532 16 57-87	Grip Handle Black

NOTE: All component dimensions given in U.S. inches
1 inch = 25.4 mm

