

**Owner's Manual
30" RIDING MOWER
SIDE DISCHARGE
ELECTRIC START**



**Catalog No.
MC30**

IMPORTANT:
Read and follow all Safety
Rules and Instructions before
operating this equipment.

Patents Pending

**Gasoline containing up to 10% ethanol (E10) is acceptable for use in this machine.
The use of any gasoline exceeding 10% ethanol (E10) will void the product warranty.**

532 44 42-30 Rev. 6

TABLE OF CONTENTS

Warranty	2	Maintenance	16
Safety Rules	3	Service and Adjustments	20
Product Specifications	6	Storage	24
Assembly/Pre-Operation	7	Troubleshooting	25
Operation	10	Repair Parts	27
Maintenance Schedule	16		

WARRANTY

LIMITED WARRANTY

The Manufacturer warrants to the original consumer purchaser that this product as manufactured is free from defects in materials and workmanship. For a period of two (2) years from date of purchase by the original consumer purchaser, we will repair or replace, at our option, without charge for parts or labor incurred in replacing parts, any part which we find to be defective due to materials or workmanship. This Warranty is subject to the following limitations and exclusions.

1. This warranty does not apply to the engine, battery (except as noted below) or components parts thereof. Please refer to the applicable manufacturer's warranty on these items.
2. Transportation charges for the movement of any power equipment unit or attachment are the responsibility of the purchaser. Transportation charges for any parts submitted for replacement under this warranty must be paid by the purchaser unless such return is requested by the manufacturer.
3. Battery Warranty: On products equipped with a Battery, we will replace, without charge to you, any battery which we find to be defective in manufacture, during the first ninety (90) days of ownership. After ninety (90) days, we will exchange the Battery, charging you 1/12 of the price of a new Battery for each full month from the date of the original sale. Battery must be maintained in accordance with the instructions furnished.
4. The Warranty does not apply to any products used for rental or commercial purposes.
5. This Warranty applies only to products which have been properly assembled, adjusted, operated, and maintained in accordance with the instructions furnished. This Warranty does not apply to any product which has been subjected to alteration, misuse, abuse, improper assembly or installation, delivery damage, or to normal wear of the product.
6. Exclusions: Excluded from this Warranty are belts, blades, blade adapters, normal wear, normal adjustments, standard hardware and normal maintenance.
7. In the event you have a claim under this Warranty, you must return the product to an authorized service dealer.

Should you have any unanswered questions concerning this Warranty, please contact:

HOP
Outdoor Products Customer Service Dept.
9335 Harris Corners Parkway
Charlotte, NC 28269 USA

In Canada contact:
HOP
5855 Terry Fox Way
Mississauga, Ontario
L5V 3E4

giving the model number, serial number and date of purchase of your product and the name and address of the authorized dealer from whom it was purchased.

THIS WARRANTY DOES NOT APPLY TO INCIDENTAL OR CONSEQUENTIAL DAMAGES AND ANY IMPLIED WARRANTIES ARE LIMITED TO THE SAME TIME PERIODS STATED HEREIN FOR OUR EXPRESSED WARRANTIES. Some areas do not allow the limitation of consequential damages or limitations of how long an implied Warranty may last, so the above limitations or exclusions may not apply to you. This Warranty gives you specific legal rights, and you may have other rights which vary from locale to locale.

This is a limited Warranty within the meaning of that term as defined in the Magnuson-Moss Act of 1975.

SUGGESTED GUIDE FOR SIGHTING SLOPES FOR SAFE OPERATION

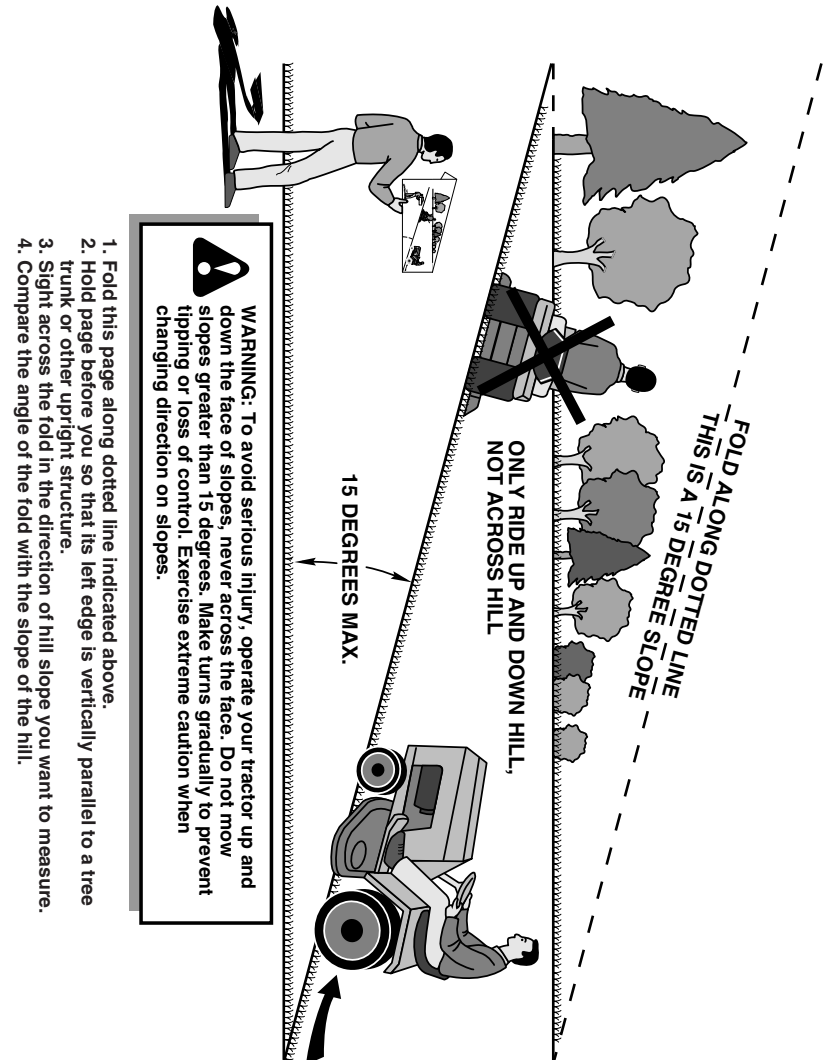

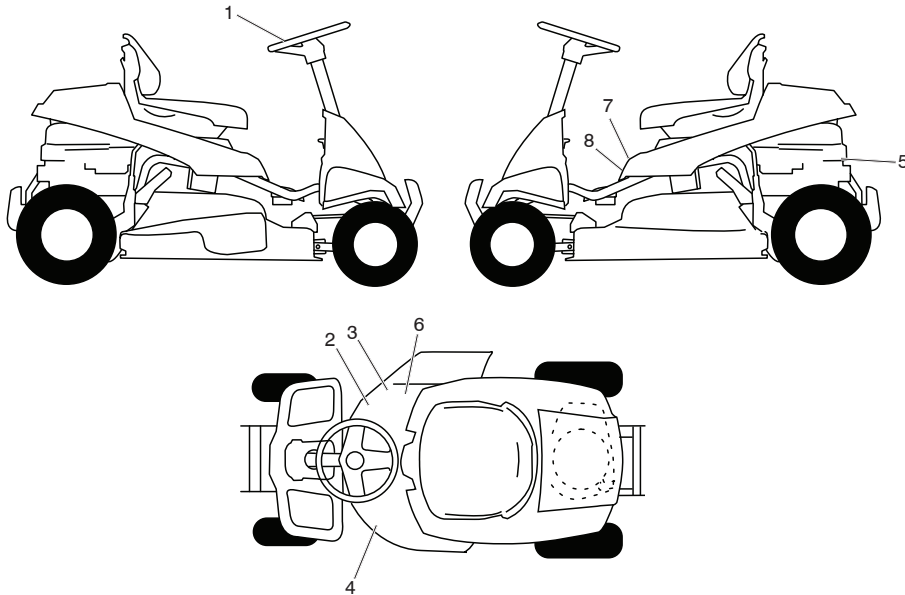

KEY NO.	PART NO.	DESCRIPTION
1	532 43 79-66	DECAL, STEERING WHEEL
2	532 44 14-97	DECAL, V-BELT SCH 30"
3	532 42 51-12	DECAL, WARN. DEFLECT/CTFGR
4	532 44 14-06	DECAL, DECK
5	532 40 88-07	DECAL, ENGINE H.P.
6	532 17 05-63	LABEL, MOWER WARN. KEEP HAND AWAY
7	532 16 88-69	DECAL, TICK
8	532 12 44-33	DECAL, 80 DBA
--	532 44 42-30	MANUAL OWNER'S ENGLISH

NOTE: All component dimensions given in U.S. inches
1 inch = 25.4 mm

SAFETY RULES

DANGER: This cutting machine is capable of amputating hands and feet and throwing objects. Failure to observe the following safety instructions could result in serious injury or death.

WARNING: In order to prevent accidental starting when setting up, transporting, adjusting or making repairs, always disconnect spark plug wire and place wire where it cannot contact spark plug.

WARNING: Do not coast down a hill in neutral, you may lose control of the riding mower.

WARNING: Engine exhaust, some of its constituents, and certain vehicle components contain or emit chemicals known to the State of California to cause cancer and birth defects or other reproductive harm.

WARNING: This unit is not intended for towing, or use of wheel weights. Only use attachments designed specifically for this riding mower.

WARNING: Battery posts, terminals and related accessories contain lead and lead compounds, chemicals known to the State of California to cause cancer and birth defects or other reproductive harm. **Wash hands after handling.**

I. GENERAL OPERATION

- Read, understand, and follow all instructions on the machine and in the manual before starting.
- Do not put hands or feet near rotating parts or under the machine. Keep clear of the discharge opening at all times.
- Only allow responsible adults, who are familiar with the instructions, to operate the machine.
- Clear the area of objects such as rocks, toys, wire, etc., which could be picked up and thrown by the blade.
- Ensure the area is clear of bystanders before operating. Stop machine if anyone enters the area.
- Never carry passengers.
- Do not mow in reverse unless absolutely necessary. Always look down and behind before and while backing.
- Never direct discharged material toward anyone. Avoid discharging material against a wall or obstruction. Material may ricochet back toward the operator. Stop the blade when crossing gravel surfaces.

- Do not operate machine without the entire grass catcher, discharge chute, or other safety devices in place and working.
- Slow down before turning.
- Never leave a running machine unattended. Always turn off blade, set parking brake, stop engine, and remove keys before dismounting.
- Disengage blade when not mowing. Shut off engine and wait for all parts to come to a complete stop before cleaning the machine, removing the grass catcher, or unclogging the discharge chute.
- Operate machine only in daylight or good artificial light.
- Do not operate the machine while under the influence of alcohol or drugs.
- Watch for traffic when operating near or crossing roadways.
- Use extra care when loading or unloading the machine into a trailer or truck.
- Always wear eye protection when operating machine.
- Data indicates that operators, age 60 years and above, are involved in a large percentage of riding mower-related injuries. These operators should evaluate their ability to operate the riding mower safely enough to protect themselves and others from serious injury.
- Keep machine free of grass, leaves or other debris build-up which can touch hot exhaust / engine parts and burn. Do not allow the mower deck to plow leaves or other debris which can cause build-up to occur. Clean any oil or fuel spillage before operating or storing the machine. Allow machine to cool before storage.

II. SLOPE OPERATION

- Slopes are a major factor related to loss of control and tip-over accidents, which can result in severe injury or death. Operation on all slopes requires extra caution. If you cannot back up the slope or if you feel uneasy on it, do not mow it.
- Mow up and down slopes (15° Max), not across.
 - Watch for holes, ruts, bumps, rocks, or other hidden objects. Uneven terrain could overturn the machine. Tall grass can hide obstacles.

SAFETY RULES



- Choose a low ground speed so that you will not have to stop or shift while on the slope.
 - Do not mow on wet grass. Tires may lose traction.
 - Always keep the machine in gear when going down slopes. Do not shift to neutral and coast downhill.
 - If machine stops while going uphill, disengage blade, shift into reverse and back down slowly.
 - Avoid starting, stopping, or turning on a slope. If the tires lose traction, disengage the blade and proceed slowly straight down the slope.
 - Keep all movement on the slopes slow and gradual. Do not make sudden changes in speed or direction, which could cause the machine to roll over.
 - Use extra care while operating machine with grass catchers or other attachments; they can affect the stability of the machine.
 - Do no use on steep slopes.
 - Do not try to stabilize the machine by putting your foot on the ground.
 - Do not mow near drop-offs, ditches, or embankments. The machine could suddenly roll over if a wheel is over the edge or if the edge caves in.
- Be alert and turn machine off if a child enters the area.
 - Before and while backing, look behind and down for small children.
 - Never carry children, even with the blade shut off. They may fall off and be seriously injured or interfere with safe machine operation. Children who have been given rides in the past may suddenly appear in the mowing area for another ride and be run over or backed over by the machine.
 - Never allow children to operate the machine.
 - Use extra care when approaching blind corners, shrubs, trees, or other objects that may block your view of a child.

IV. SERVICE

SAFE HANDLING OF GASOLINE

To avoid personal injury or property damage, use extreme care in handling gasoline. Gasoline is extremely flammable and the vapors are explosive.

- Extinguish all cigarettes, cigars, pipes, and other sources of ignition.
- Use only approved gasoline container.
- Never remove gas cap or add fuel with the engine running. Allow engine to cool before refueling.
- Never fuel the machine indoors.
- Never store the machine or fuel container where there is an open flame, spark, or pilot light such as on a water heater or other appliances.
- Never fill containers inside a vehicle or on a truck or trailer bed with plastic liner. Always place containers on the ground away from your vehicle when filling.
- Remove gas-powered equipment from the truck or trailer and refuel it on the ground. If this is not possible, then refuel such equipment with a portable container, rather than from a gasoline dispenser nozzle.
- Keep the nozzle in contact with the rim of the fuel tank or container opening at all times until fueling is complete. Do not use a nozzle lock-open device.

III. CHILDREN

WARNING: CHILDREN CAN BE INJURED BY THIS EQUIPMENT. The American Academy of Pediatrics recommends that children be a minimum of 12 year of age before operating a pedestrian controlled lawn mower and a minimum of 16 years of age before operating a riding lawn mower.

Tragic accidents can occur if the operator is not alert to the presence of children. Children are often attracted to the machine and the mowing activity. Never assume that children will remain where you last saw them.

- Keep children out of the mowing area and in the watchful care of a responsible adult other than the operator.

RIDING MOWER MOWER DECK

MODEL NUMBER MC30 (96021001700)
PRODUCT NUMBER 960 21 00-17

KEY NO.	PART NO.	DESCRIPTION
1	532 43 68-48	DECK
2	532 19 28-70	MANDREL ASM
3	532 43 68-56	KEEPER, BELT
4	532 43 68-55	PULLEY, MANDREL
5	532 44 15-97	BELT
6	532 43 68-63	COVER, MANDREL
7	532 43 71-44	LIFT ASM, DECK
8	532 42 91-95	LINK LIFT FIXED
9	532 42 93-97	LINK ASM. LIFT ADJUSTABLE
10	532 43 96-38	DEFLECTOR
12	532 43 66-47	PIN, HINGE
13	532 43 74-62	SPRING, TORSION
14	532 19 51-85	ARM, MOWER SUPPORT
17	819 19 19-12	WASHER
18	532 19 42-09	PIN
19	532 19 65-39	BOLT, SHOULDER
20	532 19 42-08	PIN COTTER 5/16 BOW TIE LOCK
21	819 17 19-12	WASHER 17/32 X 1-3/16 X 12 GA.
22	532 44 15-98	LINK ASM DECK
25	532 12 47-88	RETAINER SPRING 1"
26	532 18 76-90	SPACER, MANDREL
27	532 17 39-84	BOLT, MANDREL
28	532 40 02-34	NUT FLANGE LOCK TOP
29	532 41 92-73	BLADE
30	532 19 30-03	BOLT, BLADE
31	532 19 31-97	PULLEY, IDLER
32	532 14 10-43	GUARD, IDLER TUV
34	872 11 06-12	BOLT, 3/8-16 X 1 1/2
35	532 19 94-70	ARM, BRAKE
36	532 13 77-29	SCREW THD ROLL 1/4-20 X 5/8
37	873 90 06-00	NUT, 3/8-16 FLANGE
40	819 17 16-16	WASHER, 16 GA.
48	586 79 41-01	ARM CLUTCHING
49	532 19 90-92	SPACER RETAINER
50	817 00 06-16	SCREW 3/8-16 X 1
52	817 60 04-06	SCREW 1/4-20 X 3/8
53	532 40 18-72	SPRING RETURN DECK
55	532 43 79-88	E-RING 5/16
56	532 43 68-62	ROD ANTI-SWAY
57	819 13 13-12	WASHER 13/32 X 13/16 X 12 GA
59	532 43 68-58	GUARD TUV IDLER
61	532 43 79-47	MULCH COVER ASM
62	532 17 62-05	TRUNION SUSPENSION ARM
63	532 17 59-94	NUT LIFT LINK 7/16-20
64	817 67 06-08	SCREW THDROL 3/8-16 X 1/2

NOTE: All component dimensions given in U.S. inches
1 inch = 25.4 mm

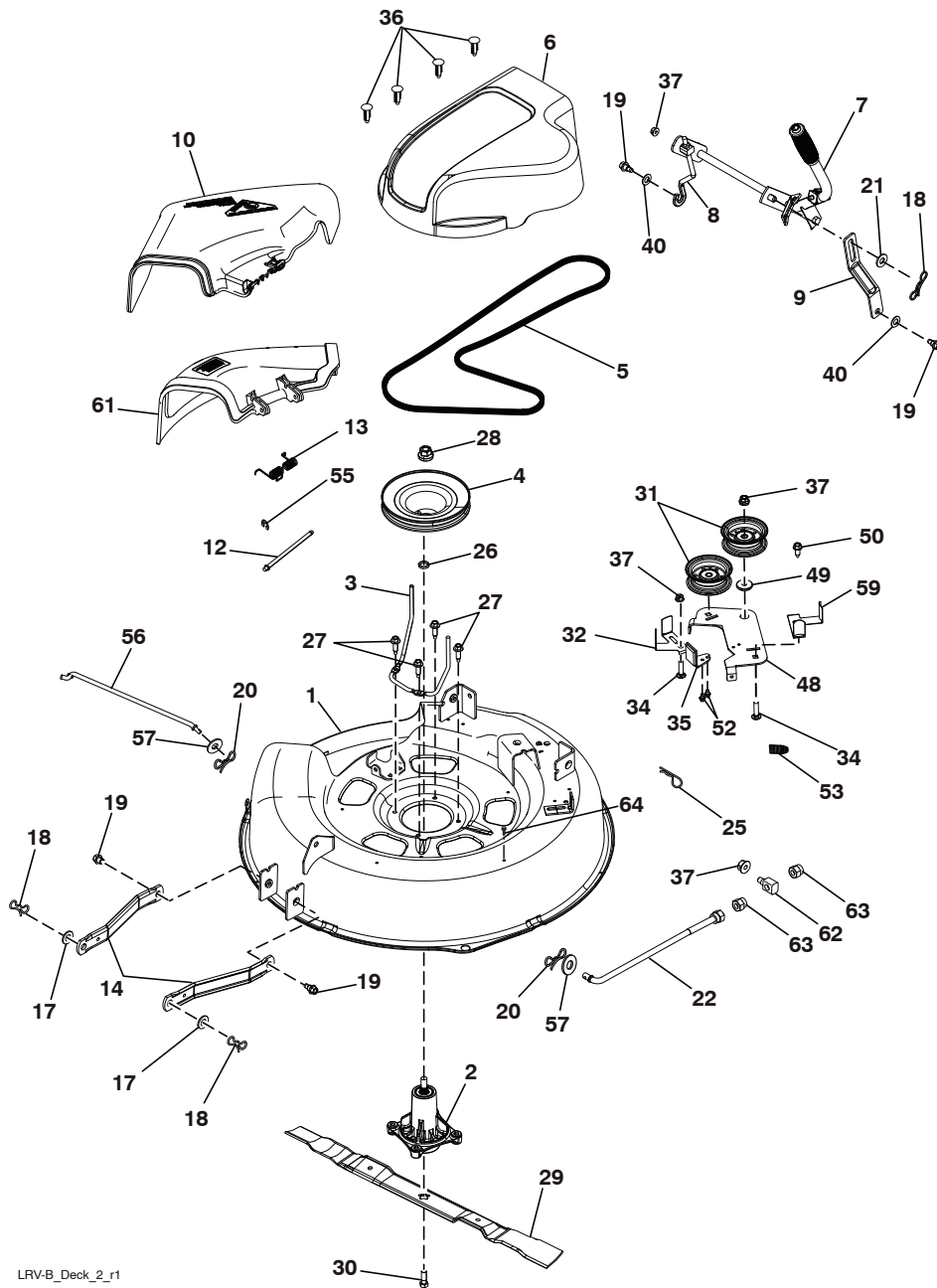

LRV-B_Deck_2_r1

SAFETY RULES

- If fuel is spilled on clothing, change clothing immediately.
- Never overfill fuel tank. Replace gas cap and tighten securely.

GENERAL SERVICE

- Never operate machine in a closed area.
- Keep all nuts and bolts tight to be sure the equipment is in safe working condition.
- Never tamper with safety devices. Check their proper operation regularly.
- Keep machine free of grass, leaves, or other debris build-up. Clean oil or fuel spillage and remove any fuel-soaked debris. Allow machine to cool before storing.
- If you strike a foreign object, stop and inspect the machine. Repair, if necessary, before restarting.
- Never make any adjustments or repairs with the engine running.

- Check grass catcher components and the discharge chute frequently and replace with manufacturer's recommended parts, when necessary.
- Mower blade is sharp. Wrap the blade or wear gloves, and use extra caution when servicing them.
- Check brake operation frequently. Adjust and service as required.
- Maintain or replace safety and instruction labels, as necessary.
- Ensure the area is clear of bystanders before operating. Stop machine if anyone enters the area.
- Never carry passengers.
- Do not mow in reverse unless absolutely necessary. Always look down and behind before and while backing.
- When loading or unloading this machine, do not exceed the maximum recommended operation angle of 15°.

PRODUCT SPECIFICATIONS

PRODUCT SPECIFICATIONS

Gasoline Capacity and Type:	1.5 Gallons Unleaded Regular
Oil Type (API SG-SL):	SAE 30 (Above 32°F) SAE 5W30 (Below 32°F)
Oil Capacity:	48 Oz.
Spark Plug:	Champion RC12YC (Gap: .030")
Ground Speed (Mph):	Forward: 0 - 4 Reverse: 0 - 2
Charging System:	3 Amps @ Battery
Blade Bolt Torque:	45-55 Ft. Lbs.

CONGRATULATIONS on your purchase of a new riding mower. It has been designed, engineered and manufactured to give you the best possible dependability and performance.

Should you experience any problem you cannot easily remedy, please contact a qualified service center. We have competent, well-trained representatives and the proper tools to service or repair this riding mower. Please read and retain this manual. The instructions will enable you to assemble and maintain your riding mower properly. Always observe the "SAFETY RULES".

CUSTOMER RESPONSIBILITIES

- Read and observe the safety rules.
- Follow a regular schedule in maintaining, caring for and using your tractor.
- Follow the instructions under "Customer Responsibilities" and "Storage" sections of this owner's manual.

⚠ WARNING: This riding mower is equipped with an internal combustion engine and should not be used on or near any unimproved forest-covered, brush-covered or grass-covered land unless the engine's exhaust system is equipped with a spark arrester meeting applicable local or state laws (if any). If a spark arrester is used, it should be maintained in effective working order by the operator.

A spark arrester for the muffler is available through your nearest authorized service center/department.

In the state of California the above is required by law (Section 4442 of the California Public Resources Code). Other states may have similar laws. Federal laws apply on federal lands.

RIDING MOWER STEERING

MODEL NUMBER MC30 (96021001700) PRODUCT NUMBER 960 21 00-17

KEY NO.	PART NO.	DESCRIPTION
1	532 44 20-64	WHEEL TUBE
2	812 00 00-01	E-CLIP
3	532 18 89-67	WASHER, HARDENED
4	532 12 17-49	WASHER, 1/4 X 3/4
5	532 43 61-81	SPINDLE, RH
6	532 12 49-31	WASHER, HARDENED THRUST
7	532 12 49-37	BUSHING, STEERING COLUMN
9	819 13 14-14	WASHER
10	532 42 80-57	WELDMENT, LWR STRG SHAFT
11	532 43 61-83	LINK, STRNG LH
12	532 43 61-84	LINK, STRNG RH
13	874 78 05-24	BOLT, 5/16-18 X 1 1/2
14	819 11 12-16	WASHER 11/32 X 3/4 X 16 GA
16	532 42 87-94	BUSHING SNAP
15	873 80 05-00	NUT, 5/16-18
17	532 43 61-78	SUPPORT, UPPER STEERING
19	817 00 05-12	BOLT, 5/16-18 X 3/4
20	532 42 80-45	CLIP, RETAINER SPRING
23	532 43 77-47	ADAPTER, STEERING WHEEL
26	532 42 45-51	WHEEL, STEERING
27	532 44 15-06	CAP, STEERING WHEEL
28	532 19 98-49	CLIP, RETAINER SPRING
29	532 43 61-80	SPINDLE LH
30	532 19 32-68	CAP, HUB, AXLE
31	819 34 32-10	WASHER 1-1/16 X 2 X 10GA.
32	817 58 05-20	SCREW HEXWSH THD 5/16-18 X 1-3/4
34	532 43 61-82	SHAFT STEERING UPPER
35	532 44 20-66	BOOT LOWER STEERING WHEEL
36	532 19 60-75	SHAFT EXTENSION STEERING SPLINE
37	874 78 05-80	BOLT FIN HEX 5/16-18 UNC X 5 GR5
38	810 04 05-00	WASHER LOCK HVY HLCL SPR 5/16
39	819 11 38-12	WASHER
41	532 43 65-90	FOAM SHAFT STEERING
42	532 42 10-76	PIN, 5/64 X 3/4 COTTER
43	873 54 05-00	CROWNLOCK NUT 5/16-24 UNF
44	532 42 80-44	BUSHING

NOTE: All component dimensions given in U.S. inches
1 inch = 25.4 mm

UNASSEMBLED PARTS

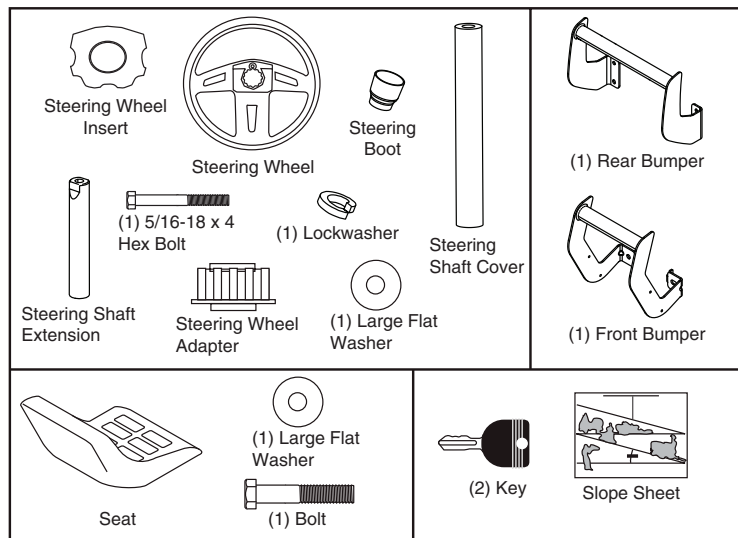

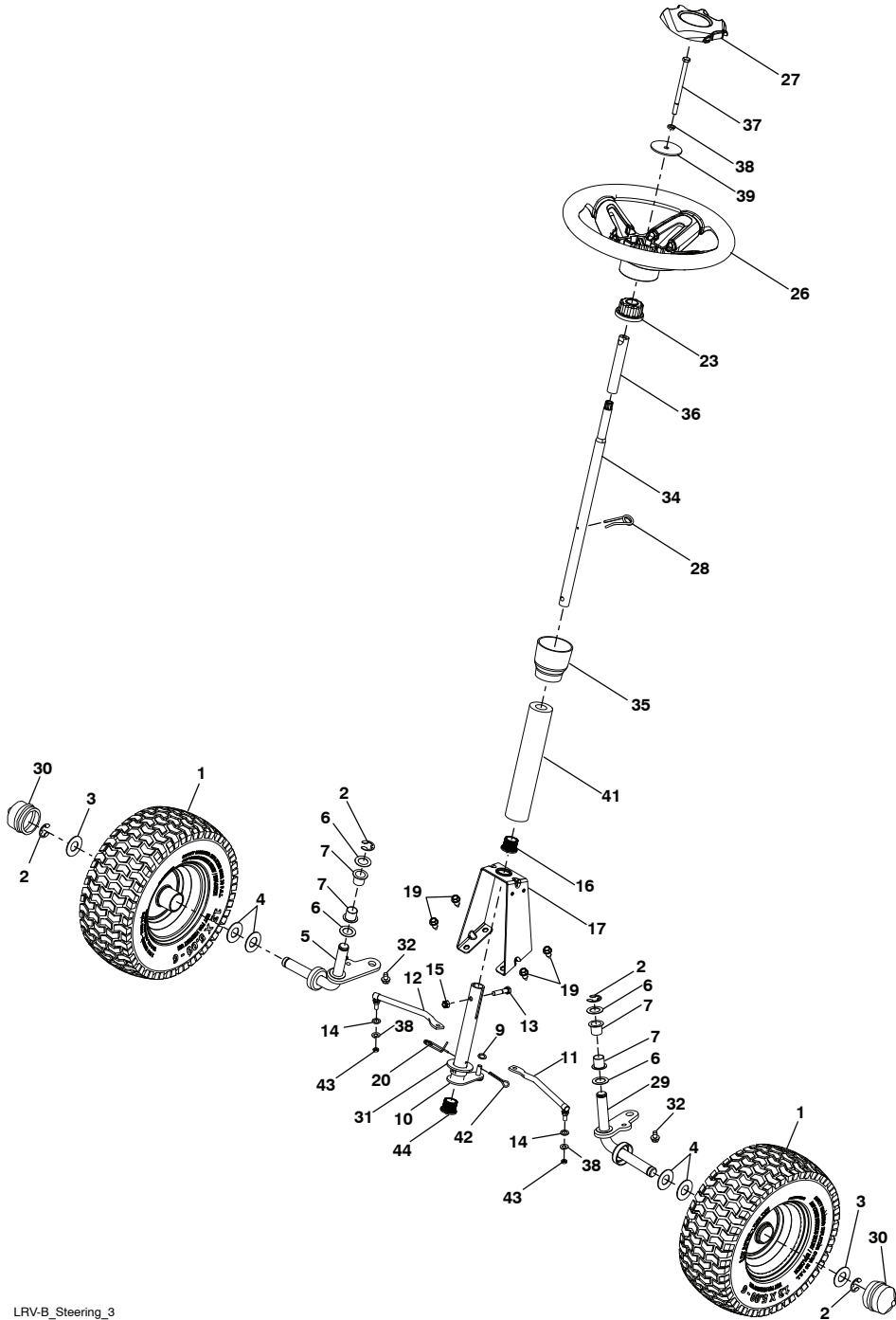

ASSEMBLY/PRE-OPERATION

Your new riding mower has been assembled at the factory with the exception of those parts left unassembled for shipping purposes. To ensure safe and proper operation of your riding mower all parts and hardware you assemble must be tightened securely. Use the correct tools as necessary to ensure proper tightness.

TOOLS REQUIRED FOR ASSEMBLY

A socket wrench set will make assembly easier. Standard wrench sizes you need are listed below.

- (1) 1/2" wrench
- (1) Utility knife
- (1) Tire pressure gauge

When right or left hand is mentioned in this manual, it means when you are in the operating position (seated behind the steering wheel).

TO REMOVE RIDING MOWER FROM CARTON

UNPACK CARTON

1. Remove all accessible loose parts and parts boxes from carton.
2. Cut along dotted lines on all four panels of carton. Remove end panels and lay side panels flat.
3. Remove packing materials from riding mower.
4. Check for any additional loose parts or cartons and remove.

NOTE: Only cut carton with a short blade utility knife, a long blade or saw can puncture tires on unit.

HOW TO SET UP YOUR RIDING MOWER

CHECK BATTERY

Ensure battery is securely fastened, and that all wires are securely connected.

- Battery is located under the seat.
- Battery has been fully charged from the factory, before installation.

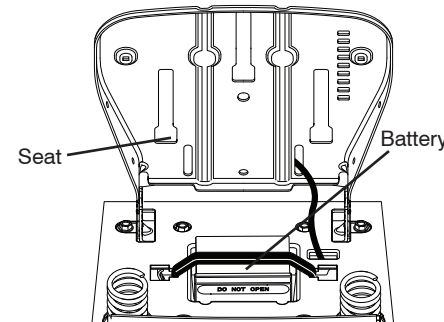

TO INSTALL STEERING WHEEL

1. Slide extension shaft onto steering shaft.
2. Slide steering shaft protective foam cover over steering shaft.
3. Place steering boot over steering shaft and push down to secure.
4. Position front wheels of the riding mower so they are pointing straight forward.
5. Remove steering wheel adapter from steering wheel and slide adapter onto steering shaft.
6. Press steering wheel into position on shaft, install large washer, lock washer, bolt and tighten securely.
7. Snap steering wheel insert into center of steering wheel securely.

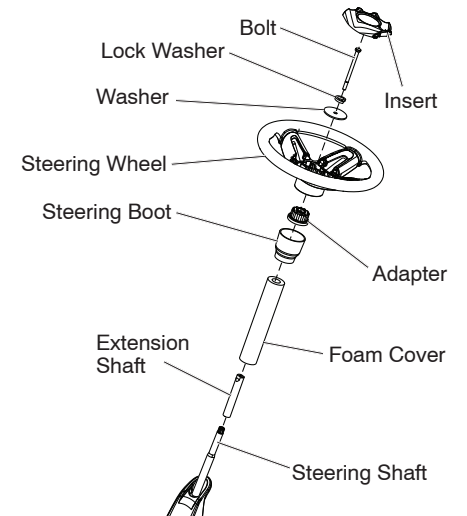

INSTALL SEAT

1. Remove bolt and flat washer securing seat to cardboard packing and set aside for assembly of seat to riding mower. Remove the cardboard packing and discard.
2. Place seat on seat pan so all three (3) bottom pads are positioned over large slotted holes in pan.
3. Push down on seat to engage pads in slots and pull seat towards rear of riding mower.
4. Raise seat and tighten bolt and large flat washer securely.
5. Remove tape and discard.
6. Lower seat into operating position and sit on seat. Press clutch/brake pedal all the way down. If operating position is not comfortable, adjust seat.

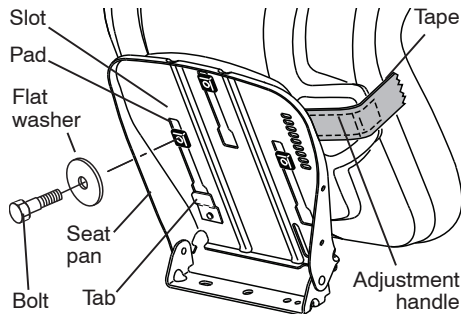

TO ADJUST SEAT

FRONT AND BACK -

- Sit in seat.
- Lift up adjustment lever and slide seat until a comfortable position is reached which allows you to press clutch/brake pedal all the way down.
- Release lever to lock seat in position.

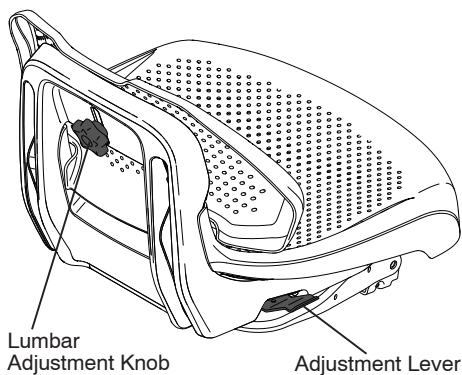

LUMBAR SUPPORT -

- Loosen lumbar adjustment knob.
- Slide seat back up or down to most comfortable position for lower back support.
- Tighten lumbar adjustment knob.

NOTE: You may now roll your riding mower off the skid. Follow the appropriate instruction below to remove the riding mower from the skid.

⚠ WARNING: Before starting, read, understand and follow all instructions in the Operation section of this manual. Be sure riding mower is in a well-ventilated area. Be sure the area in front of riding mower is clear of other people and objects.

TO ROLL RIDING MOWER OFF SKID (See Operation section for location and function of controls)

1. Raise deck lift lever to its highest position.
2. Release parking brake by depressing clutch/brake pedal.
3. Shift unit to neutral.
4. Roll riding mower forward off skid.

TO ATTACH FRONT BUMPER

NOTE: For ease of assembly, you may wish to obtain the assistance of another person for mounting bumper to riding mower.

1. Remove (2) screws from front chassis of riding mower.
2. Tilt the front bumper so that the bumper tabs catch the slots on the front of the chassis and lower the bumper in to place.
3. Attach the bumper to front of chassis with screws removed in step 1.
4. Tighten the two (2) screws securely.

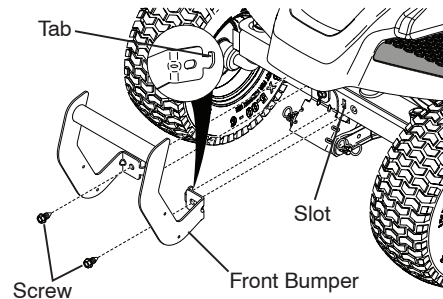

RIDING MOWER DRIVE

KEY NO.	PART NO.	DESCRIPTION	KEY NO.	PART NO.	DESCRIPTION
1	532 44 20-79	WHEEL ASM (REAR)	70	580 96 23-01	GRIP LEVER
2	532 12 17-48	WASHER, 16 GA.	71	532 43 68-65	TUBE SHIFT LRV
3	812 00 00-01	E-CLIP	72	872 11 04-06	BOLT CARR.
6	532 15 69-72	SPACER AXLE	73	873 68 04-00	NUT CROWNLOCK 1/4-20 UNC
7	874 78 04-28	HCS 1/4-20 X 1-3/4 GR 5 ZD	75	532 43 67-58	BRACKET MOUNT SHIFT
8	532 43 66-95	WELMENT SUPPORT AXLERH	76	532 18 39-00	HUB SHIFT
9	532 44 39-89	SUBASM FINAL DRIVE	78	532 42 90-55	SPACER NYLON .866 X 1.25 X .250
10	817 00 05-12	SCREW 5/16 - 18 X 3/4	79	874 78 04-12	BOLT.FIN.HEX.1/4-20UNCX.75
11	532 43 67-41	BRACKET.SUPPORT.RH	80	810 04 04-00	WASHER LOCK HVY HLCL SPRING
12	532 44 74-24	CASE CHAIN RH	81	819 09 12-10	WASHER 9/32 X 3/4 X 10 GA.
13	532 43 72-80	BEARING BALL 6207-SRS	84	819 11 16-10	WASHER 11/32 X 1.00 X 10 GA.
14	532 43 71-76	SPROCKET DRIVEN 37 TOOTH	85	532 43 69-14	SPRING FRICTION PACK
15	532 44 29-53	TUBE INPUT HEX	86	532 43 73-04	BUSHING PACK FRICTION FD2
16	532 43 61-53	CHAIN PRIMARY DRIVE	87	532 43 69-48	WASHER PLASTIC
17	532 43 72-82	BEARING BALL 6204-3-2RS	88	532 43 67-01	STUD PACK FRICTION
18	532 43 61-49	CASE CHAIN LH	89	532 43 72-99	SPACER PACK FRICTION FD2
19	818 05 10-10	SCREW 10-24 X 5/8 PAN HEAD TORX	90	819 11 14-16	WASHER.11/32 X 7/8 X 16 GA.
20	532 12 49-31	WASHER	91	532 43 69-24	SUBASM.LINK.SHIFT
22	532 43 66-96	WELMENT SUPPORT AXLE LH	94	532 43 69-18	WELDMENT.SHIFT.FD2
23	818 05 10-10	SCREW TORX #10 - 14 X 1/2	95	532 43 68-66	PLATE.SHIFT
32	532 43 61-51	BLOCK TENSION CHAIN	96	532 44 47-17	DRUM CLUTCH MULTI DISC
33	532 43 61-50	SPRING ADJUSTER TENSION	97	532 43 69-25	SUBASM LINK SHIFT PRIMARY
34	877 10 10-40	PIN CLEVIS 5/16 X 2-1/2	98	532 15 03-60	NUT LOCK CENTER 1/4 - 28 FNTHD
36	532 44 62-78	SHAFT INPUT CLUTCH	101	817 06 06-24	SCREW.3/8-16X1-1/2. SMGML TAP/R
37	532 43 61-52	SPROCKETSPLINED 14 TOOTH	102	532 08 67-77	THREAD.CUTTER
39	532 43 04-70	BEARING BALL	103	532 10 44-45	SWITCH.SEAT.
40	532 43 69-39	ARM BRAKE	104	532 44 47-15	HUB CENTER
41	532 10 95-53	SWITCH INTLK CL MWR GRY 4 TERM	105	532 43 61-42	SPRING WAVE C125-H5
43	873 80 05-00	NUT LOCK HEX W/INSERT 5/16 - 18 UNC	106	532 19 43-21	SPACER RETAINER
44	532 43 66-52	COVER END HEX	107	532 12 47-88	RETAINER.SPRING.1".ZINC/CAD
45	532 43 61-54	SPRING DRIVE	108	532 43 67-84	BUSHING.5/16IDX7/16ODX1/2
47	532 43 69-49	BRACKET MOUNT CABLE LRV B	109	532 19 32-68	CAPHUB.AXLE.1.50 X 1.00
48	817 54 10-16	SCREW.HEX.HEAD WASH.10-24X1.00	110	532 42 84-61	BRACKET SHIFTER FLEX
51	532 43 67-39	BRACKET SUPPORT LH	111	532 12 35-83	KEY.SQUARE.2.0 X .1845/.1865
53	873 90 06-00	LOCK NUT, FLANGED	112	818 10 10-12	SCREW TORX #10-14 X .750
54	532 43 57-26	BEARING BALL	113	873 90 05-00	NUT LOCK FLANGE HEX
55	532 44 47-16	COVER WHEEL CLUTCH	114	532 43 62-82	BEARING FLANGE
57	532 43 65-59	WHEEL FRICTION	117	532 44 62-00	SCREW
59	532 44 10-97	PLATE CLUTCH.DRIVE	118	532 44 25-01	CAP.TUBE.HEX
60	532 43 77-87	PLATE PRESSURE DRIVE	119	873 35 06-00	NUT.HEX 3/8-16 UNC
62	532 43 77-86	PLATE CLUTCH BRAKE			
63	532 43 77-85	PLATE PRESSURE BRAKE			
65	532 44 58-14	PLATE PRESSURE MASTER			
66	532 43 57-24	BEARING THRUST 20MM			
67	532 44 58-15	PLATE THROWOUT			
68	532 44 58-17	BEARING BALL LOOSE			
69	532 44 58-16	COVER CLUTCH			

NOTE: All component dimensions given in U.S. inches
1 inch = 25.4 mm

**RIDING MOWER
DRIVE**

**MODEL NUMBER MC30 (96021001700)
PRODUCT NUMBER 960 21 00-17**

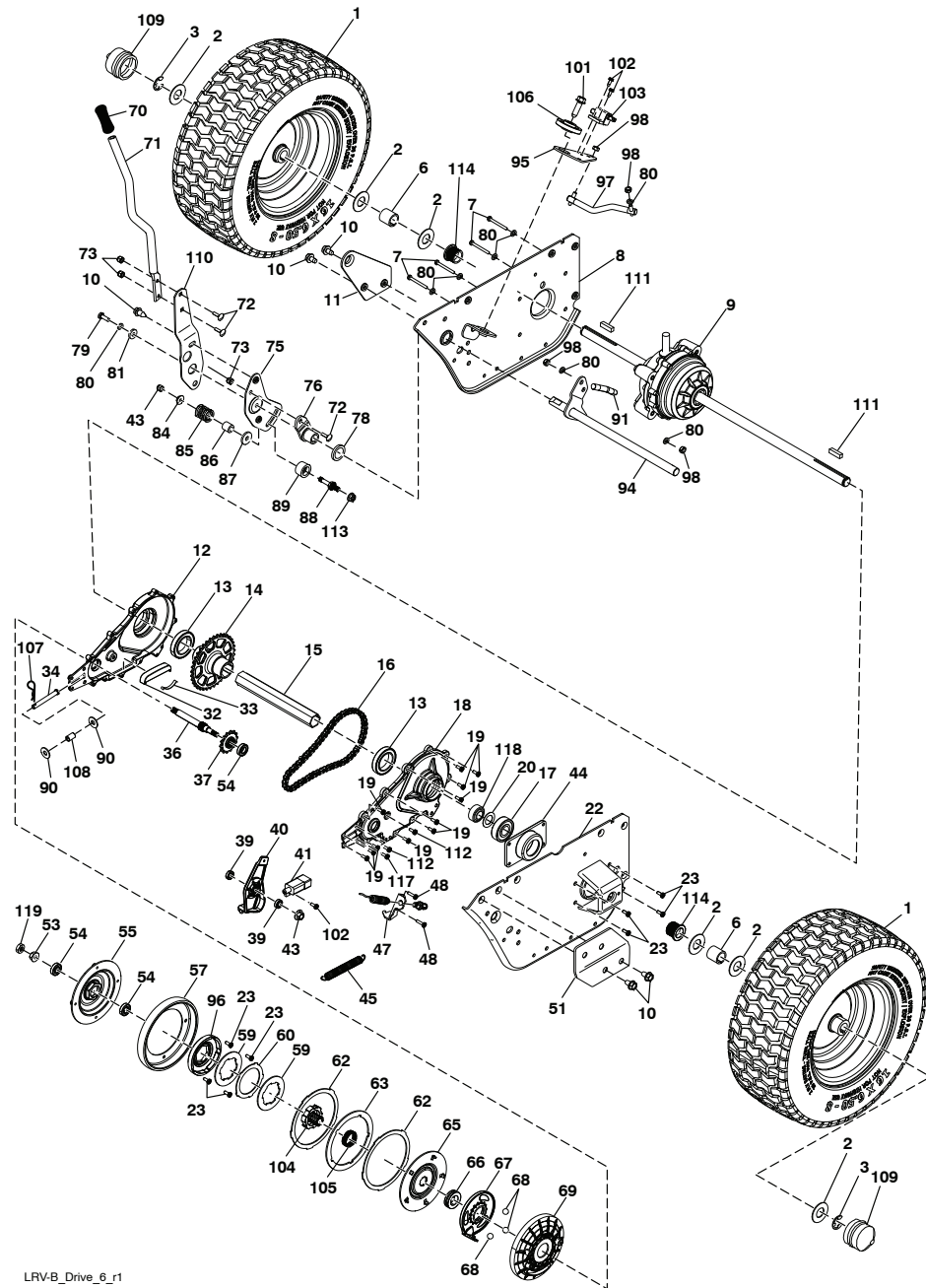

LRV-B_Drive_6_r1

TO ATTACH REAR BUMPER

NOTE: For ease of assembly, you may wish to obtain the assistance of another person for mounting bumper to riding mower.

1. Remove (4) screws from rear chassis of riding mower.
2. Position bumper as shown and assemble to rear chassis with screws removed in step 1.
3. Tighten the four (4) screws securely.

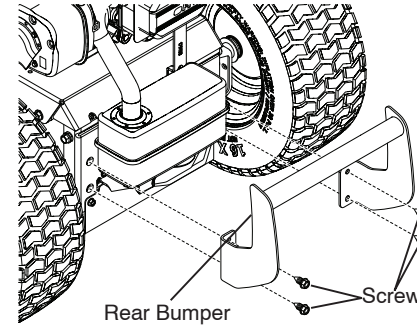

CHECK TIRE PRESSURE

The tires on your riding mower were overinflated at the factory for shipping purposes. Correct tire pressure is important for best cutting performance.

CHECK DECK LEVELNESS

For best cutting results, mower housing should be properly leveled. See "TO LEVEL MOWER HOUSING" in the Service and Adjustments section of this manual.

CHECK FOR PROPER POSITION OF MOWER DRIVE BELT

See the figure that is shown for replacing the mower drive belt in the service and adjustment section of this manual. Verify that the belt is routed correctly.

CHECK BRAKE SYSTEM

After you learn how to operate your riding mower, check to see that the brake is operating properly.

✓ CHECKLIST

Before you operate your new riding mower, we wish to assure that you receive the best performance and satisfaction from this Quality Product.

Please review the following checklist:

- ✓ All assembly instructions have been completed.
- ✓ No remaining loose parts in carton.
- ✓ Battery is properly connected.
- ✓ Seat is adjusted comfortably and tightened securely.
- ✓ All tires are properly inflated. (For shipping purposes, the tires were overinflated at the factory).
- ✓ Be sure mower deck is properly leveled side-to-side/front-to-rear for best cutting results. (Tires must be properly inflated for leveling).
- ✓ Check mower belt. Be sure it is routed properly around pulleys and inside all belt keepers.
- ✓ Check wiring. See that all connections are still secure and wires are properly clamped.

While learning how to use your riding mower, pay extra attention to the following important items:

- ✓ Engine oil is at proper level.
- ✓ Fuel tank is filled with fresh, clean, regular unleaded gasoline.
- ✓ Become familiar with all controls, their location and function. Operate them before you start the engine.
- ✓ Be sure brake system is in safe operating condition.
- ✓ Be sure Operator Presence System and Reverse Operation System (ROS) are working properly (See the Operation and Maintenance sections in this manual).

OPERATION



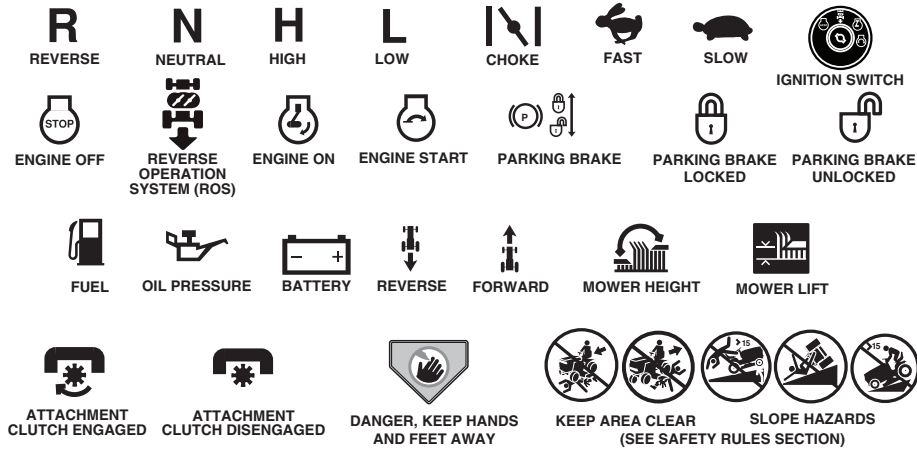



These symbols may appear on your riding mower or in literature supplied with the product. Learn and understand their meaning.



BRAKE/CLUTCH PEDAL



Failure to follow instructions could result in serious injury or death. The safety alert symbol is used to identify safety information about hazards which can result in death, serious injury and/or property damage.

-  **DANGER** indicates a hazard which, if not avoided, will result in death or serious injury.
-  **WARNING** indicates a hazard which, if not avoided, could result in death or serious injury.
-  **CAUTION** indicates a hazard which, if not avoided, might result in minor or moderate injury.
-  **CAUTION** when used **without** the alert symbol, indicates a situation that **could result in damage to the tractor and/or engine.**
-  **HOT SURFACES** indicates a hazard which, if not avoided, **could result in death, serious injury and/or property damage.**
-  **FIRE** indicates a hazard which, if not avoided, **could result in death, serious injury and/or property damage.**

RIDING MOWER CHASSIS

MODEL NUMBER MC30 (96021001700) PRODUCT NUMBER 960 21 00-17

KEY NO.	PART NO.	DESCRIPTION	KEY NO.	PART NO.	DESCRIPTION
1	532 43 61-76	WELDMENT, CHASSIS	70	532 44 20-68	CONSOLE CENTER
2	532 18 01-66	BRACKET, SEAT			CUPHOLDER
7	532 43 61-77	PLATE, ENGINE	71	532 43 78-57	THROTTLE ASM
8	532 43 68-60	BRACKET, CHASSIS FRONT	72	532 19 51-61	STUD FASTNER
10	532 44 18-05	PAN, SEAT	73	873 90 05-00	NUTLOCKHEXFLANGE5/16-18
11	532 19 93-70	BRACKET, SWITCHMOUNTING	74	873 90 04-00	NUT HEX FLANGE 1/4-20
13	532 44 20-71	COVER, FOOT REST	75	532 43 69-59	CABLE BRAKE
14	532 44 20-75	FOOTREST STRUCTURAL	76	877 10 08-12	PIN CLEVIS
15	532 44 20-69	SUPPORT, FOOT REST	77	876 02 02-08	THRITTLE ASM 1/16 X 1/2
16	532 43 93-95	PANEL ASM, CONTROL	78	532 43 70-56	BRACKET SUPPORT ROD
18	---	---	79	532 43 70-57	BRAKE WELDMENT
			80	532 42 96-93	BRAKE PEDAL COVER
			81	532 43 73-74	WELDMENTLINKCONNECTING
			82	532 16 94-84	RETAINER CLIP
			83	532 43 93-67	STEERING TOWER REAR
19	532 43 68-61	KEEPER, BELT	84	532 43 92-88	STEERING BOOT FRONT
22	532 44 21-30	DECK CLUTCH ASM	85	532 43 76-60	PARKING BRAKE HANDLE
23	532 14 98-46	KNOB	86	532 43 87-62	ACTUATOR PARKING BRAKE
24	532 41 63-58	SCREW #10 X 0.750 BOS THREAD	87	532 16 54-92	SHOULDER BOLT
			88	532 42 81-10	CROSS BRACE
25	872 14 04-24	BOLT	91	532 43 74-01	TRACK CLUTCH BRKT
26	873 51 04-00	NUT 1/4-20	94	874 49 05-48	BOLT
29	532 43 89-21	BOLT, 7/16-20 X 1.00	95	532 44 42-71	BRACKET CLUTCHING
32	817 06 06-20	SCREW 3/8-16 X 1-1/4	96	532 44 20-73	BUMPER REAR
33	532 12 41-81	SPRING, SEAT	97	532 43 64-72	PULLEY ENGINE
34	532 12 37-40	SPRING	100	532 19 76-61	HANDLE SLIDE SEAT
35	872 05 04-12	BOLT, 1/4-20 X 1 1/2	101	532 19 82-00	SPRING LATCH SEAT
39	532 13 43-00	SPACER	102	874 76 06-12	BOLT FIN HEX 3/8-16 UNC X 3/4
40	532 12 12-48	BUSHING, NYLON SNAP	103	819 13 38-12	WASHER 13/32 X 2 3/8 X 12 GA
41	532 12 39-76	NUT, LOCK	104	818 10 10-08	SCREW TORX #10-14 X 1/2
42	532 17 18-52	BOLT, 5/16-18 SHOULDER	105	532 44 20-78	ENGINE COVER
43	873 80 05-00	NUT, 5/16-18	106	532 43 68-34	STRAP BATTERY
44	532 43 66-12	SEAT	107	532 44 20-74	FRONT BRUSH GUARD
45	817 00 05-12	BOLT, 5/16-18 X 3/4	108	532 43 71-68	COVER REAR TRANSAXLE
51	532 42 88-56	BRACKET	109	532 43 90-08	BRAKE HANDLE PLATE
52	532 14 50-06	CLIP PUSH-IN HINGED	110	532 42 21-45	CONTROL PANEL HINGE PIN
53	532 43 85-62	SCREW	111	532 43 81-71	SHIELD, BRAKE CABLE
54	532 43 64-73	DISC FRICTION	112	817 72 04-08	SCREW THD CUT
55	532 43 58-08	TORSION BODY UPPER	113	817 06 05-12	SCREW 5/16-18 X 3/4
56	532 44 19-25	TORSION BODY LOWER	117	532 19 91-62	WASHER 1.5 X .50 X .118
57	532 43 64-79	SPRING HELIX			
60	532 43 78-58	FUEL TANK ASM			
63	532 41 41-19	PURGE LINE			
64	532 12 34-87	CLAMP HOSE			
65	532 43 85-96	FUEL CAP			
66	532 43 66-06	FUEL TANK SUPPORT BRKT			
67	532 42 17-56	SCREW #10 X 0.500			
68	532 43 98-51	SHIELD HEAT			
69	532 43 74-27	BRACKET MOUNT CABLE			

NOTE: All component dimensions given in U.S. inches
1 inch = 25.4 mm

**RIDING MOWER
CHASSIS**

**MODEL NUMBER MC30 (96021001700)
PRODUCT NUMBER 960 21 00-17**

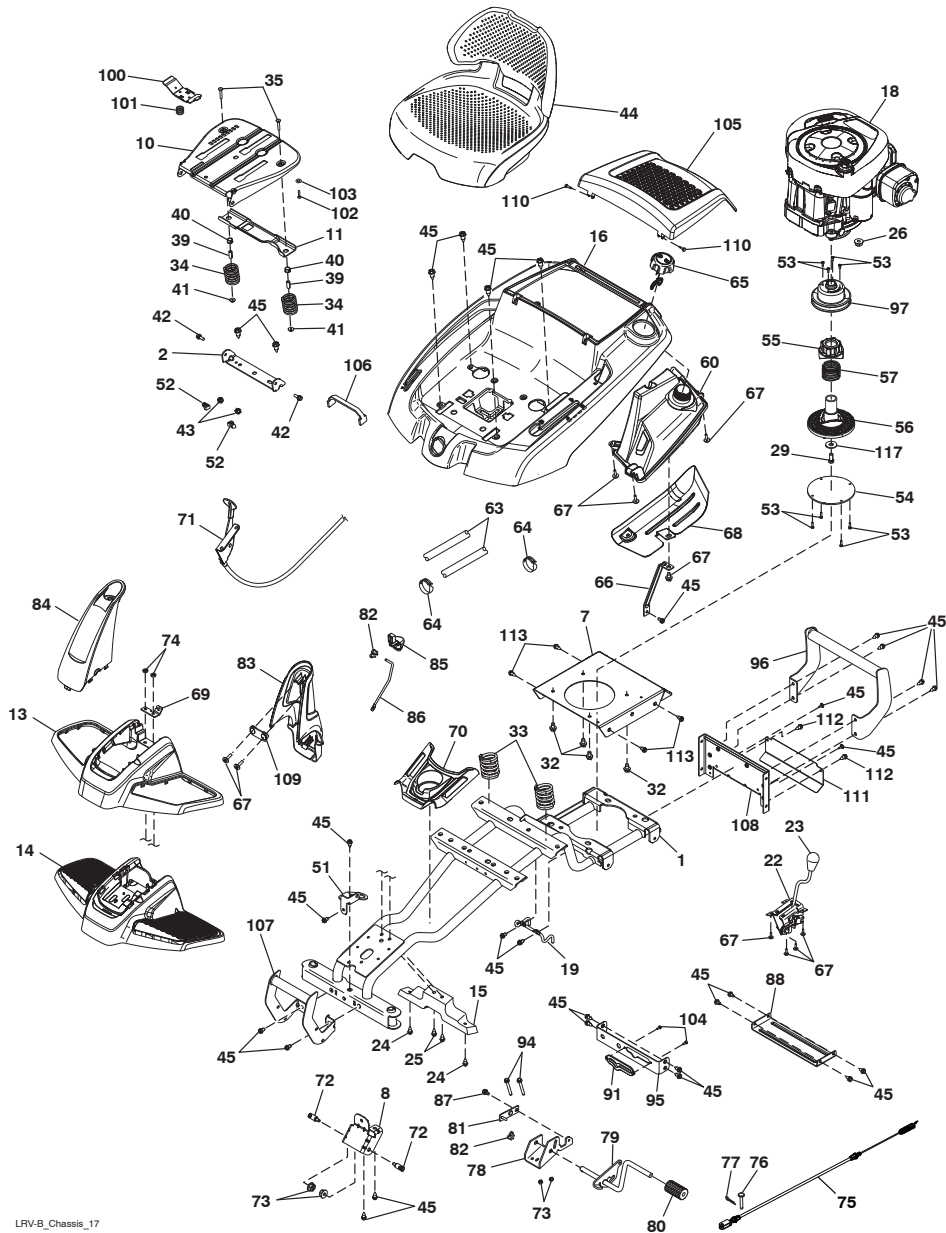

LRV-B_Chassis_17

**KNOW YOUR RIDING MOWER
READ THIS OWNER'S MANUAL AND SAFETY RULES BEFORE OPERATING
YOUR RIDING MOWER**

Compare the illustrations with your riding mower to familiarize yourself with the locations of various controls and adjustments. Save this manual for future reference.

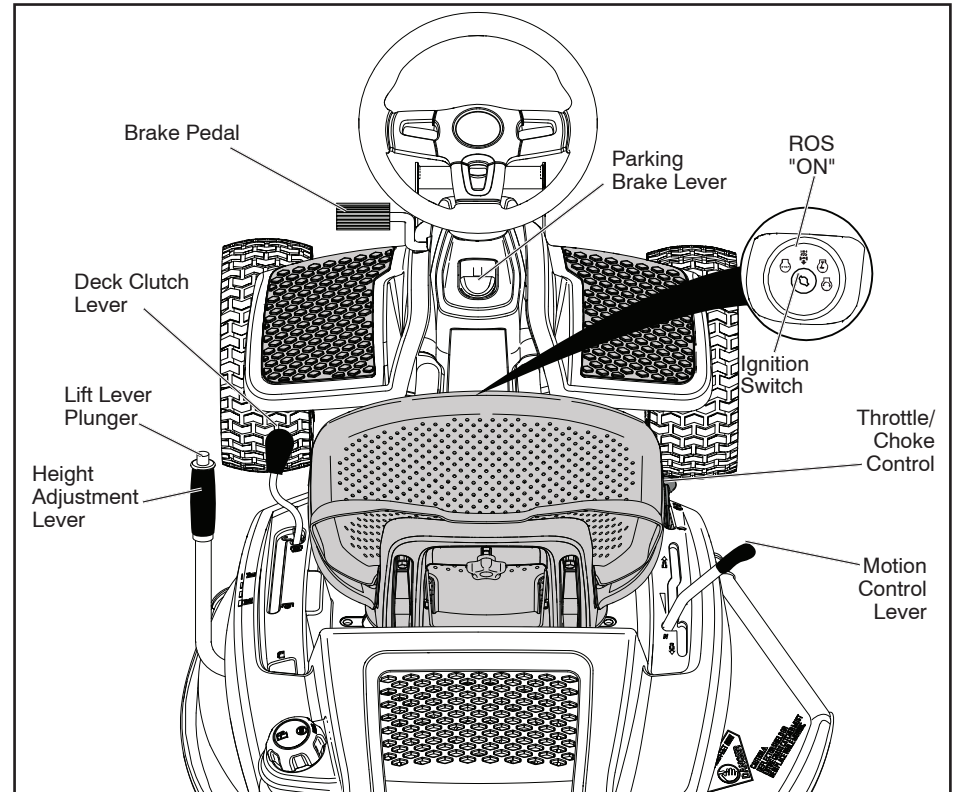

Our riding mowers conform to the applicable safety standards of the American National Standards Institute.

DECK CLUTCH LEVER - Used to engage the mower blade.

BRAKE PEDAL - Used for braking the riding mower and starting the engine.

HEIGHT ADJUSTMENT LEVER - Used to adjust mower cutting height.

IGNITION SWITCH - Used for starting and stopping the engine.

LIFT LEVER PLUNGER - Used to release height adjustment lever when changing its position.

PARKING BRAKE LEVER - Locks parking brake into brake position.

MOTION CONTROL LEVER - Selects the speed and direction of the riding mower.

ROS "ON" POSITION - Allows operation of mower deck or other powered attachment while in reverse.

THROTTLE/CHOKE CONTROL - Used for starting and controlling engine speed.



The operation of any riding mower can result in foreign objects thrown into the eyes, which can result in severe eye damage. Always wear safety glasses or eye shields while operating your riding mower or performing any adjustments or repairs. We recommend a wide vision safety mask over spectacles or standard safety glasses.

HOW TO USE YOUR RIDING MOWER

TO SET PARKING BRAKE

Your riding mower is equipped with an operator presence sensing switch. When engine is running, any attempt by the operator to leave the seat without first setting the parking brake will shut off the engine.

1. Depress brake pedal all the way down and hold.
2. Pull parking brake lever up and hold, release pressure from brake pedal, then release parking brake lever. Pedal should remain in brake position. Ensure parking brake will hold mower secure.

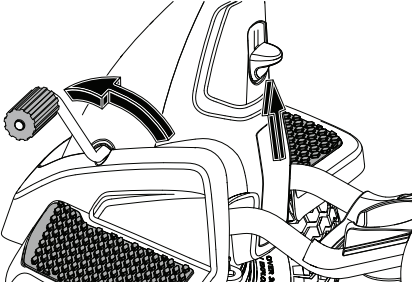

STOPPING

MOWER BLADE -

- To stop mower blade, move deck clutch lever to disengaged position.

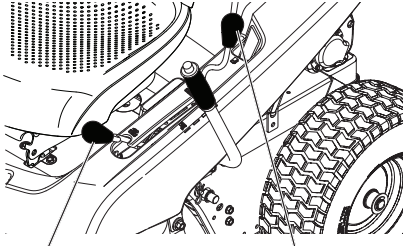

 Deck Clutch Control "Engaged"  Deck Clutch Control "Disengaged"

GROUND DRIVE -

- To stop ground drive, depress brake pedal all the way down.
- Move motion control lever to neutral position.

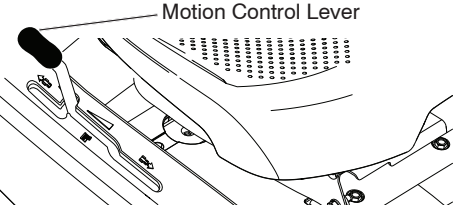

ENGINE -

- Move throttle control between half and full speed (fast) position.

NOTE: Failure to move throttle control between half and full speed (fast) position, before stopping, may cause engine to "backfire".

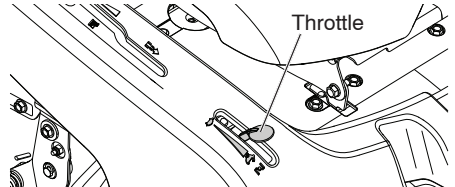

- Turn ignition key to "STOP" position and remove key. Always remove key when leaving riding mower to prevent unauthorized use.

IMPORTANT: Leaving the ignition switch in any position other than "STOP" will cause the battery to discharge and go dead.

NOTE: Under certain conditions when riding mower is standing idle with the engine running, hot engine exhaust gases may cause "browning" of grass. To eliminate this possibility, always stop engine when stopping riding mower on grass areas.

CAUTION: Always stop riding mower completely, as described above, before leaving the operator's position.

TO USE THROTTLE CONTROL

Always operate engine at full speed (fast).

- Operating engine at less than full speed (fast) reduces engine's operating efficiency.
- Full speed (fast) offers the best mower performance.

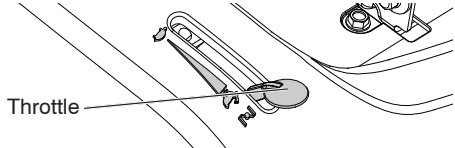

RIDING MOWER ELECTRICAL

MODEL NUMBER MC30 (96021001700) PRODUCT NUMBER 960 21 00-17

KEY NO.	PART NO.	DESCRIPTION
1	532 43 65-51	BATTERY
3	532 19 33-50	SWITCH, IGN, DLTA, P-IN, ROS
4	532 41 19-33	KEY/CHAIN
9	532 10 95-53	SWITCH, INTLK,CL, MWR, GRY
10	532 17 61-38	SWITCH, INTERLOCK, NONC,GRAY
12	532 19 27-49	SWITCH, SEAT, DP, ROS
13	532 43 72-28	HARNES, IGN, ELECTSTART, LRV
15	532 19 25-07	SOLENOID
16	817 72 04-08	SCREW THD CUT 1/4-20 X 1/2 TY23
17	873 51 04-00	NUT KEPS HEX 1/4-20 UNC
18	532 41 66-94	CABLE BATTERY
19	532 42 12-99	CABLE STARTER
20	532 42 12-98	CABLE GROUND
21	817 06 05-12	SCREW 5/16-18 X 3/4
22	532 44 21-48	SCREW HEX M5X0.8.9MM
23	532 43 81-22	NUT M5
24	818 10 10-12	SCREW TORX #10-14 X .750
25	532 43 48-99	FUSE, 10

NOTE: All component dimensions given in U.S. inches
1 inch = 25.4 mm

LRV2



TO MOVE FORWARD AND BACKWARD

The direction and speed of movement is controlled by the motion control lever.

1. Ensure the parking brake is applied.
2. Start riding mower with motion control lever in neutral (N) position.
3. Release parking brake.
4. Slowly move motion control lever to desired position.

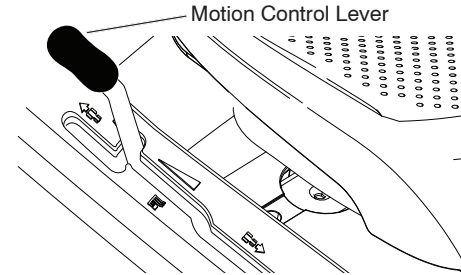

TO ADJUST MOWER CUTTING HEIGHT

The position of the mower height deck lift lever determines the cutting height.

- Grasp lift lever.
- Press lift lever plunger with thumb and move lever to desired position.

The cutting height range is approximately 1-1/2 to 4". The heights are measured from the ground to the blade tip with the engine not running. These heights are approximate and may vary depending upon soil conditions, height of grass and types of grass being mowed.

- The average lawn should be cut to approximately 2-1/2" during the cool season and to over 3" during hot months. For healthier and better looking lawns, mow often and after moderate growth.
- For best cutting performance, grass over 6" in height should be mowed twice. Make the first cut relatively high; the second to desired height.

TO OPERATE MOWER

Your riding mower is equipped with an operator presence sensing switch. Any attempt by the operator to leave the seat with the engine running and the deck clutch engaged will shut off the engine. You must remain fully and centrally positioned in the seat to prevent the engine from hesitating or cutting off when operating your equipment on rough, rolling terrain or hills.

1. Select desired height of cut.
2. Start mower blade by engaging deck clutch lever.

TO STOP MOWER BLADE -
Disengage deck clutch lever.

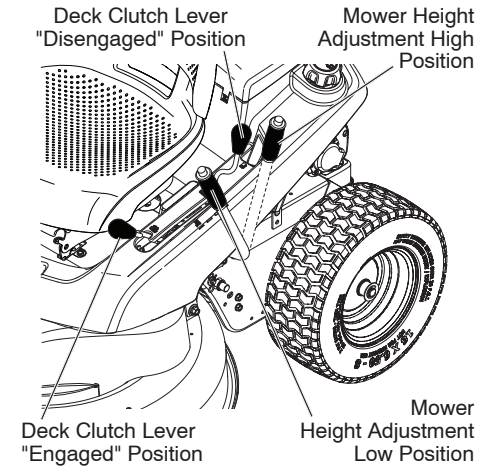

CAUTION: Do not operate the mower without either the entire grass catcher, on mowers so equipped, mulch cover, or the deflector shield in place.

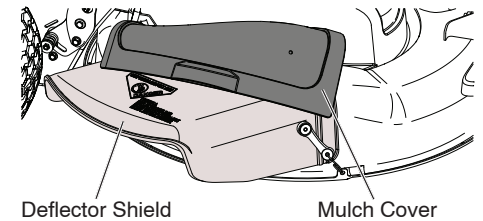

REVERSE OPERATION SYSTEM (ROS)

Your riding mower is equipped with a Reverse Operation System (ROS). Any attempt by the operator to travel in the reverse direction with the deck clutch engaged will shut off the engine unless ignition key is placed in the ROS "ON" position.

WARNING: Backing up with the deck clutch engaged while mowing is strongly discouraged. Turning the ROS "ON", to allow reverse operation with the deck clutch engaged, should only be done when the operator decides it is necessary to reposition the machine with the attachment engaged. **Do not mow in reverse unless absolutely necessary.**

USING THE REVERSE OPERATION SYSTEM -

Only use if you are certain no children or other bystanders will enter the mowing area.

1. Move motion control lever to neutral (N) position.
2. With engine running, turn ignition key counterclockwise to ROS "ON" position.
3. Look down and behind before and while backing.
4. Slowly move motion control lever to reverse (R) position to start movement.
5. When use of the ROS is no longer needed, turn the ignition key clockwise to engine "ON" position.



ROS "ON" Position



Engine "ON" Position
(Normal Operating)

TO ATTACH DEFLECTOR

1. Unhook the 2 bungees from deck to the mulch cover.

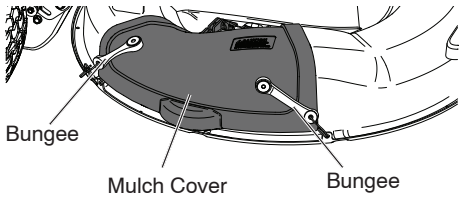

2. Lift the mulch cover.
3. Attach the deflector to the hinge bracket.

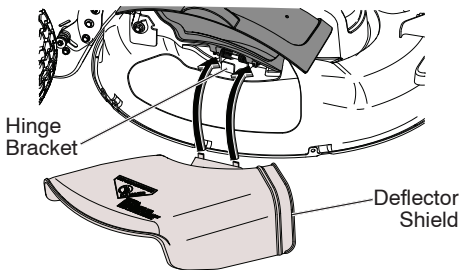

4. Rest the mulch cover on the deflector.
5. Attach the 2 bungees from the deflector to the deck.

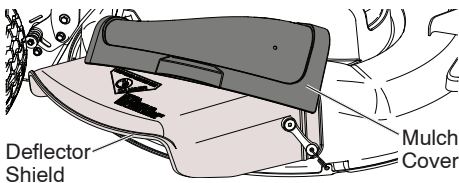

TO OPERATE ON HILLS

WARNING: Do not drive up or down hills with slopes greater than 15° and do not drive across any slope. Use the slope guide at the back of this manual.

- Choose the slowest speed before starting up or down hills.
- Avoid stopping or changing speed on hills.
- If stopping is absolutely necessary, push clutch/brake pedal quickly to brake position and engage parking brake.
- Move motion control lever to neutral (N) position.
- To restart movement, slowly release parking brake and clutch/brake pedal.
- Make all turns slowly.

TO TRANSPORT

When pushing or towing your riding mower, be sure to disengage transmission by placing shifter in neutral.

- Raise mower height adjustment to its highest position with mower height adjustment lever.
- To reengage transmission, press brake and shift out of neutral.

BEFORE STARTING THE ENGINE CHECK ENGINE OIL LEVEL

The engine in your riding mower has been shipped, from the factory, already filled with summer weight oil.

1. Check engine oil with riding mower on level ground.
 2. Remove oil fill cap/dipstick and wipe clean, reinsert the dipstick and screw cap tight, wait for a few seconds, remove and read oil level. If necessary, add oil until "FULL" mark on dipstick is reached. Do not overfill.
- For cold weather operation you should change oil for easier starting (See the oil viscosity chart in the Maintenance section of this manual).
 - To change engine oil, see the Maintenance section in this manual.

ADD GASOLINE

- Fill fuel tank to bottom of filler neck. Do not overfill. Use fresh, clean, regular unleaded gasoline with a minimum of 87 octane. (Use of leaded gasoline will increase carbon and lead oxide deposits and reduce valve life). Do not mix oil with gasoline. Purchase fuel in quantities that can be used within 30 days to assure fuel freshness.

CAUTION: Wipe off any spilled oil or fuel. Do not store, spill or use gasoline near an open flame.

RIDING MOWER SCHEMATIC

MODEL NUMBER MC30 (96021001700)
PRODUCT NUMBER 960 21 00-17

SCH24

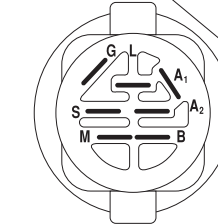
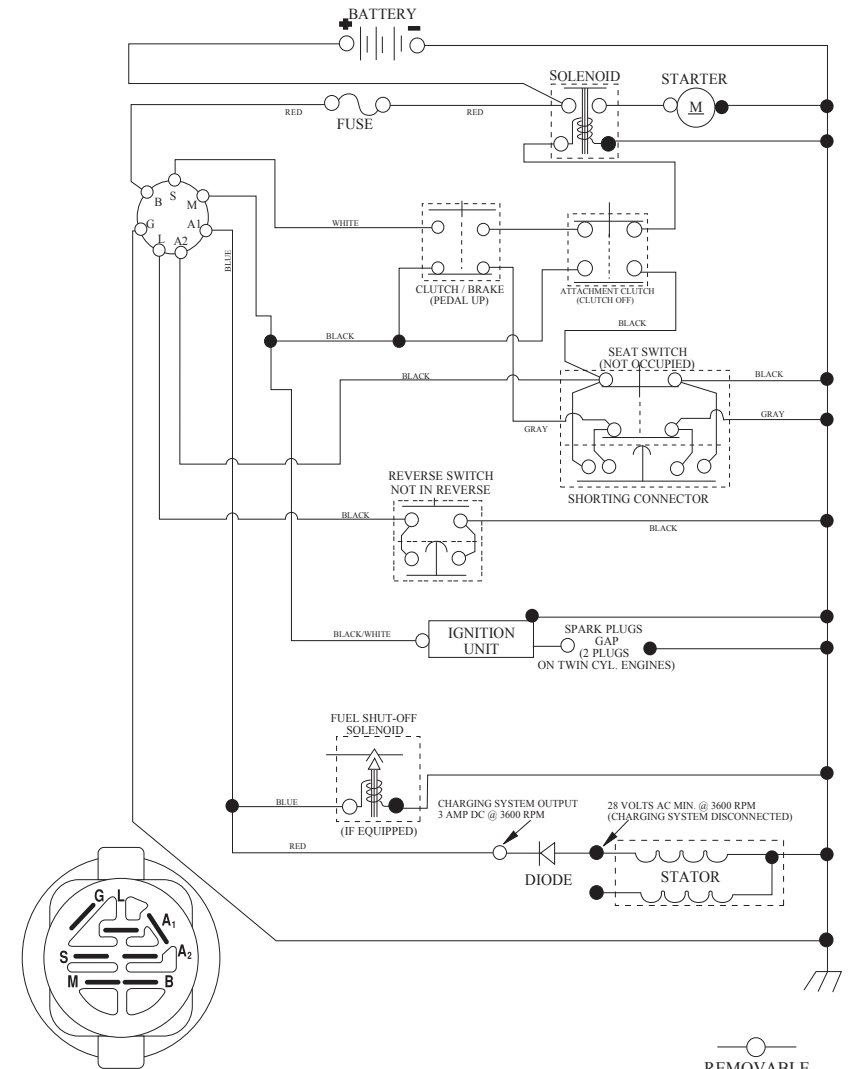

IGNITION SWITCH

POSITION	CIRCUIT	"MAKE"
OFF	M+G+A1	
RUN/OVERRIDE	B+A1	
RUN	B+A1	L+A2
START	B+S+A1	

WIRING INSULATED CLIPS
NOTE: IF WIRING INSULATED CLIPS WERE REMOVED FOR SERVICING OF UNIT, THEY SHOULD BE RE-INSTALLED TO PROPERLY SECURE YOUR WIRING.

○
REMOVABLE
CONNECTIONS

●
NON-REMOVABLE
CONNECTIONS

TROUBLESHOOTING CHART:

See appropriate section in manual unless directed to an authorized service center.

PROBLEM	CAUSE	CORRECTION
Poor cut - uneven cutting	1 Worn, bent or loose blade.	1 Replace blade. Tighten blade bolt.
	2 Mower deck not level.	2 Level mower deck.
	3 Buildup of grass, leaves, and trash under mower.	3 Clean underside of mower housing.
	4 Bent blade mandrel.	4 Contact a qualified service center.
	5 Clogged mower deck vent from build-up of grass, leaves, and trash around mandrel.	5 Clean around mandrels to open vent holes.
Mower blade will not rotate	1 Obstruction in clutch mechanism.	1 Remove obstruction.
	2 Worn/damaged mower drive belt.	2 Replace mower drive belt.
	3 Frozen idler pulley.	3 Replace idler pulley.
	4 Frozen blade mandrel.	4 Contact a qualified service center.
Poor grass discharge	1 Travel speed too fast.	1 Shift to slower speed.
	2 Wet grass.	2 Allow grass to dry before mowing.
	3 Mower deck not level.	3 Level mower deck.
	4 Low/uneven tire air pressure.	4 Check tires for proper PSI.
	5 Worn, bent or loose blade.	5 Replace/sharpen blade. Tighten blade bolt.
	6 Buildup of grass, leaves and trash under mower.	6 Clean underside of mower housing.
	7 Mower drive belt worn.	7 Replace mower drive belt.
	8 Blade improperly installed.	8 Reinstall blade sharp edge down.
	9 Improper blade used.	9 Replace with blade listed in parts manual.
	10 Clogged mower deck vent from build-up of grass, leaves, and trash around mandrel.	10 Clean around mandrels to open vent holes.
Battery will not charge	1 Bad battery cell(s).	1 Replace battery.
	2 Poor cable connections.	2 Check/clean all connections.
	3 Faulty alternator.	3 Replace alternator.
Loss of drive	1 Axle key missing.	1 Install axle key at rear wheel. See "TO REMOVE WHEEL" in the Service and Adjustments section.
	2 Clutch out of adjustment.	2 Adjust clutch. See "TO ADJUST CLUTCH" in the Service and Adjustments section.
Engine dies when riding mower is shifted into reverse	1 Reverse operation system (ROS) is not "ON" while mower or other attachment is engaged.	1 Turn ignition key to ROS "ON" position. See Operation section.
	2 Engine is cold.	2 Allow engine warm-up by running for several seconds to several minutes.

CAUTION: Alcohol blended fuels (called gasohol or using ethanol or methanol) can attract moisture which leads to separation and formation of acids during storage. Acidic gas can damage the fuel system of an engine while in storage. To avoid engine problems, the fuel system should be emptied before storage of 30 days or longer. Drain the gas tank, start the engine and let it run until the fuel lines and carburetor are empty. Use fresh fuel next season. See Storage Instructions for additional information. Never use engine or carburetor cleaner products in the fuel tank or permanent damage may occur.

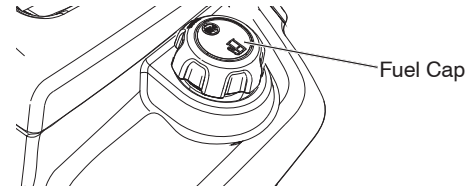

TO START ENGINE

When starting the engine for the first time or if the engine has run out of fuel, it will take extra cranking time to move fuel from the tank to the engine.

- Sit on seat in operating position, depress clutch/brake pedal and set parking brake.
- Place motion control lever in neutral position.
- Move deck clutch lever to "DISENGAGED" position.
- Move throttle control to choke position.

NOTE: Before starting, read the warm and cold starting procedures below.

- Insert key into ignition and turn key clockwise to "START" position and release key as soon as engine starts. Do not run starter continuously for more than fifteen seconds per minute. If the engine does not start after several attempts, move throttle control to fast position, wait a few minutes and try again. If engine still does not start, move the throttle control back to the choke position and retry.

WARM WEATHER STARTING (50°F/10°C AND ABOVE)

- When engine starts, move the throttle control to the fast position.
- The ground drive can now be used. If the engine does not accept the load, restart the engine and allow it to warm up for one minute using the choke as described above.

COLD WEATHER STARTING (50°F/10°C AND BELOW)

- When engine starts, allow engine to run with the throttle control in the choke position until the engine runs roughly, then move throttle control to fast position. This may require an engine warm-up period from several seconds to several minutes, depending on the temperature.

MOWING TIPS

- Mower should be properly leveled for best mowing performance. See "TO LEVEL MOWER HOUSING" in the Service and Adjustments section of this manual.
- The left hand side of mower should be used for trimming.
- Drive so that clippings are discharged onto the area that has already been cut. Have the cut area to the right of the riding mower. This will result in a more even distribution of clippings and more uniform cutting.

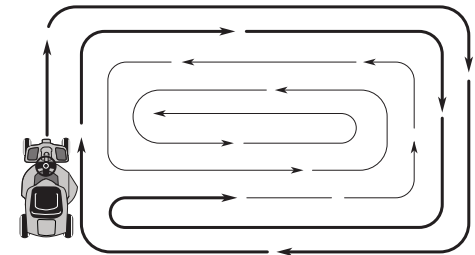

- When mowing large areas, start by turning to the right so that clippings will discharge away from shrubs, fences, driveways, etc. After one or two rounds, mow in the opposite direction making left hand turns until finished.
- If grass is extremely tall, it should be mowed twice to reduce load and possible fire hazard from dried clippings. Make first cut relatively high; the second to the desired height.
- Do not mow grass when it is wet. Wet grass will plug mower and leave undesirable clumps. Allow grass to dry before mowing.
- Regulate ground speed by selecting a low enough gear to give the mower cutting performance as well as the quality of cut desired.
- When operating attachments, select a ground speed that will suit the terrain and give best performance of the attachment being used.

MAINTENANCE

MAINTENANCE SCHEDULE		BEFORE EACH USE	EVERY 8 HOURS	EVERY 25 HOURS	EVERY 50 HOURS	EVERY 100 HOURS	EVERY SEASON	BEFORE STORAGE
RIDING MOWER	Check Brake Operation	✓	✓					
	Check Tire Pressure	✓	✓					
	Check Operator Presence & ROS Systems	✓						
	Check for Loose Fasteners	✓				✓		✓
	Check/Replace Mower Blade			✓ ³				✓
	Clean Battery and Terminals			✓				✓
	Adjust Clutch			✓	✓	✓		
	Lubricate Axles and Spindles			✓				
	Clean Friction Surfaces			✓ ⁴				✓
Check Mower Levelness				✓				
Check V-Belt					✓			
ENGINE	Check Engine Oil Level	✓	✓					
	Change Engine Oil			✓ ^{1,2}				✓
	Clean Air Filter			✓ ²				
	Clean Air Screen			✓ ²				
	Inspect Muffler/Spark Arrester				✓			
	Clean Engine Cooling Fins					✓ ²		
Replace Spark Plug					✓	✓		
Replace Air Filter Paper Cartridge					✓ ²			

1 - Change more often when operating under a heavy load or in high ambient temperatures. 3 - Replace blade more often when mowing in sandy soil
 2 - Service more often when operating in dirty or dusty conditions. 4 - Clean surfaces with isopropyl alcohol or non flammng cleaner.

GENERAL RECOMMENDATIONS

The warranty on this riding mower does not cover items that have been subjected to operator abuse or negligence. To receive full value from the warranty, operator must maintain riding mower as instructed in this manual.

Some adjustments will need to be made periodically to properly maintain your riding mower.

At least once a season, check to see if you should make any of the adjustments described in the Service and Adjustments section of this manual.

- At least once a year you should replace the spark plug, clean or replace air filter, and check blade and belt for wear. A new spark plug and clean air filter assure proper air-fuel mixture and help your engine run better and last longer.

BEFORE EACH USE

- Check engine oil level.
- Check brake operation.
- Check tire pressure.
- Check operator presence and ROS systems for proper operation.
- Check for loose fasteners.

IMPORTANT: Do not oil or grease the pivot points which have special nylon bearings. Viscous lubricants will attract dust and dirt that will shorten the life of the self-lubricating bearings. If you feel they must be lubricated, use only a dry, powdered graphite type lubricant sparingly.

TROUBLESHOOTING CHART:

See appropriate section in manual unless directed to an authorized service center.

PROBLEM	CAUSE	CORRECTION
Will not start	1 Out of fuel.	1 Fill fuel tank.
	2 Bad spark plug.	2 Replace spark plug.
	3 Dirty air filter.	3 Clean/replace air filter.
	4 Water in fuel.	4 Empty fuel tank and carburetor, refill tank with fresh gasoline and replace fuel filter.
	5 Loose or damaged wiring.	5 Check all wiring.
	6 Engine valves out of adjustment.	6 Contact a qualified service center.
Hard to start	1 Dirty air filter.	1 Clean/replace air filter.
	2 Bad spark plug.	2 Replace spark plug.
	3 Weak or dead battery.	3 Recharge or replace battery.
	4 Stale or dirty fuel.	4 Empty fuel tank and refill tank with fresh, clean gasoline.
	5 Loose or damaged wiring.	5 Check all wiring.
	6 Engine valves out of adjustment.	6 Contact a qualified service center.
Engine will not turn over	1 Clutch/brake pedal not depressed.	1 Depress clutch/brake pedal.
	2 Deck clutch is engaged.	2 Disengage deck clutch.
	3 Weak or dead battery.	3 Recharge or replace battery.
	4 Blown fuse.	4 Replace fuse.
	5 Corroded battery terminals.	5 Clean battery terminals.
	6 Loose or damaged wiring.	6 Check all wiring.
	7 Faulty ignition switch.	7 Check/replace ignition switch.
	8 Faulty solenoid or starter.	8 Check/replace solenoid or starter.
	9 Faulty operator presence switch(es).	9 Contact a qualified service center.
Engine clicks but will not start	1 Weak or dead battery.	1 Recharge or replace battery.
	2 Corroded battery terminals.	2 Clean battery terminals.
	3 Loose or damaged wiring.	3 Check all wiring.
	4 Faulty solenoid or starter.	4 Check/replace solenoid or starter.
Loss of power	1 Cutting too much grass/too fast.	1 Raise cutting height/reduce speed.
	2 Build-up of grass, leaves and trash under mower.	2 Clean underside of mower housing.
	3 Dirty air filter.	3 Clean/replace air filter.
	4 Low oil level/dirty oil.	4 Check oil level/change oil.
	5 Faulty spark plug.	5 Clean & regap or change spark plug.
	6 Stale or dirty fuel.	6 Empty fuel tank and refill tank with fresh, clean gasoline.
	7 Water in fuel.	7 Empty fuel tank and carburetor, refill tank with fresh gasoline.
	8 Spark plug wire loose.	8 Connect & tighten spark plug wire.
	9 Dirty engine air screen/fins.	9 Clean engine air screen/fins.
	10 Dirty/clogged muffler.	10 Clean/replace muffler.
	11 Loose or damaged wiring.	11 Check all wiring.
	12 Engine valves out of adjustment.	12 Contact a qualified service center.
Excessive vibration	1 Worn, bent or loose blade.	1 Replace blade. Tighten blade bolt.
	2 Bent blade mandrel.	2 Contact a qualified service center.
	3 Loose/damaged part(s).	3 Tighten loose part(s). Replace damaged parts.
Engine continues to run when operator leaves seat with attachment clutch engaged	1 Faulty operator-safety presence control system.	1 Check wiring, switches and connections. If not corrected, Contact a qualified service center.

STORAGE

Immediately prepare your riding mower for storage at the end of the season or if the riding mower will not be used for 30 days or more.

WARNING: Never store the riding mower with gasoline in the tank inside a building where fumes may reach an open flame or spark. Allow the engine to cool before storing in any enclosure.

MOWER

Remove deck from mower for winter storage. When mower is to be stored for a period of time, clean it thoroughly, remove all dirt, grease, leaves, etc. Store in a clean, dry area.

1. Clean entire riding mower (See "CLEANING" in the Maintenance section of this manual).
2. Inspect and replace belt, if necessary (See belt replacement instructions in the Service and Adjustments section of this manual).
3. Lubricate as shown in the Maintenance section of this manual.
4. Be sure that all nuts, bolts and screws are securely fastened. Inspect moving parts for damage, breakage and wear. Replace if necessary.
5. Touch up all rusted or chipped paint surfaces; sand lightly before painting.

BATTERY

- Fully charge the battery for storage.
- If battery is removed from riding mower for storage, do not store battery directly on concrete or damp surfaces.

ENGINE

FUEL SYSTEM

IMPORTANT: It is important to prevent gum deposits from forming in essential fuel system parts such as carburetor, fuel hose, or tank during storage. Also, alcohol blended fuels (called gasohol or using ethanol or methanol) can attract moisture which leads to separation and formation of acids during storage. Acidic gas can damage the fuel system of an engine while in storage.

- Empty the fuel tank by starting the engine and letting it run until the fuel lines and carburetor are empty.
- Never use engine or carburetor cleaner products in the fuel tank or permanent damage may occur.
- Use fresh fuel next season.

NOTE: Fuel stabilizer is an acceptable alternative in minimizing the formation of fuel gum deposits during storage. Add stabilizer to gasoline in fuel tank or storage container. Always follow the mix ratio found on stabilizer container. Run engine at least 10 minutes after adding stabilizer to allow the stabilizer to reach the carburetor. Do not empty the gas tank and carburetor if using fuel stabilizer.

ENGINE OIL

Drain oil (with engine warm) and replace with clean engine oil. (See "ENGINE" in the Maintenance section of this manual).

CYLINDER(S)

1. Remove spark plug(s).
2. Pour one ounce of oil through spark plug hole(s) into cylinder(s).
3. Turn ignition key to "START" position for a few seconds to distribute oil.
4. Replace with new spark plug(s).

OTHER

- Do not store gasoline from one season to another.
 - Replace your gasoline can if your can starts to rust. Rust and/or dirt in your gasoline will cause problems.
 - If possible, store your riding mower indoors and cover it to give protection from dust and dirt.
 - Cover your riding mower with a suitable protective cover that does not retain moisture. Do not use plastic. Plastic cannot breathe which allows condensation to form and will cause your riding mower to rust.
- IMPORTANT:** Never cover riding mower while engine and exhaust areas are still warm.

RIDING MOWER

Always observe safety rules when performing any maintenance.

BRAKE OPERATION

If riding mower requires more than four (4) feet to stop at highest speed in highest gear on a level, dry concrete or paved surface, then brake must be serviced at your nearest authorized service center.

TIRES

- Maintain tire pressure at 12 PSI.
- Keep tires free of gasoline, oil, or insect control chemicals which can harm rubber.
- Avoid stumps, stones, deep ruts, sharp objects and other hazards that may cause tire damage.

NOTE: To seal tire punctures and prevent flat tires due to slow leaks, tire sealant may be purchased from your local parts dealer. Tire sealant also prevents tire dry rot and corrosion.

AXLE AND SPINDLES

- Front wheel axles and front spindles should be properly lubricated.
- Wheel axles and spindles should be lubricated with grease.

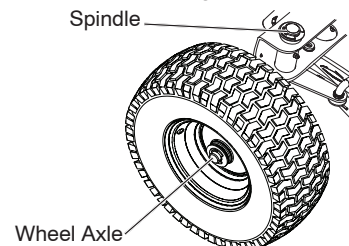

OPERATOR PRESENCE SYSTEM AND REVERSE OPERATION SYSTEM (ROS)

Be sure operator presence and reverse operation systems are working properly. If your riding mower does not function as described, repair the problem immediately.

- The engine should not start unless the brake pedal is fully depressed, and the deck clutch lever is in the disengaged position.

CHECK OPERATOR PRESENCE SYSTEM

- When the engine is running, any attempt by the operator to leave the seat without first setting the parking brake should shut off the engine.
- When the engine is running and the deck clutch lever is engaged, any attempt by the operator to leave the seat should shut off the engine.
- Never operate the deck clutch lever unless you are seated in the seat.

CHECK REVERSE OPERATION (ROS) SYSTEM

- When the engine is running with the ignition switch in the engine "ON" position and the deck clutch lever engaged, any attempt by the operator to shift into reverse should shut off the engine.
- When the engine is running with the ignition switch in the ROS "ON" position and the deck clutch lever engaged, any attempt by the operator to shift into reverse should NOT shut off the engine.



ROS "ON" Position



Engine "ON" Position (Normal Operating)

BLADE CARE

For best results mower blades must be sharp. Replace worn, bent or damaged blades.

CAUTION: Use only a replacement blade approved by the manufacturer of your riding mower. Using a blade not approved by the manufacturer of your riding mower is hazardous, could damage your riding mower and void your warranty.

BLADE REMOVAL

1. Raise mower to highest position to allow access to blade.
- NOTE:** Protect your hands with gloves and/or wrap blade with heavy cloth.
2. Remove blade bolt by turning counter-clockwise.
 3. Install new blade with stamped "THIS SIDE UP" facing deck and mandrel assembly.

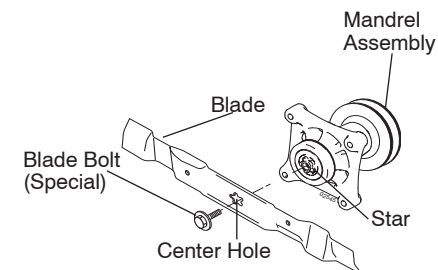

IMPORTANT: To ensure proper assembly, center hole in blade must align with star on mandrel assembly.

4. Install and tighten blade bolt securely (45-55 Ft. Lbs.).

IMPORTANT: Special blade bolt is heat treated.

BATTERY

Your riding mower has a battery charging system which is sufficient for normal use.

- Keep battery and connectors clean.
- Only recharge battery with charger approved for a 12V 6 amp. hour battery.
- Charging with any other charger or an automotive style charger can cause permanent damage to the battery.
- Charge battery for 24 hours for a full charge.

NOTE: The original equipment battery on your riding mower is maintenance free. Do not attempt to open or remove caps or covers. Adding or checking level of electrolyte is not necessary.

⚠ WARNING: Do not jump start battery. Permanent damage to the battery or personal injury may occur.

TRANSAXLE COOLING

Keep transaxle free from build-up of dirt and chaff which can restrict cooling.

V-BELT

Check V-belt for deterioration and wear after 100 hours of operation and replace if necessary. The belt is not adjustable. Replace belt if it begins to slip from wear.

ENGINE

LUBRICATION

Only use high quality detergent oil rated with API service classification SG-SL. Select the oil's SAE viscosity grade according to your expected operating temperature.

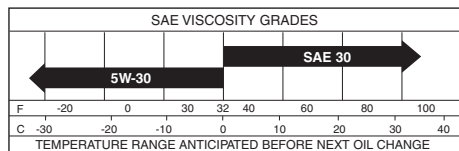

NOTE: Although multi-viscosity oils (5W30, 10W30 etc.) improve starting in cold weather, the oils will result in increased oil consumption when used above 32°F. Check your engine oil level more frequently to avoid possible engine damage from running low on oil. Change the oil after every 25 hours of operation or at least once a year if the riding mower is not used for 25 hours in one year. Check the crankcase oil level before starting the engine and after each eight (8) hours of operation. Tighten oil fill cap/dipstick securely each time you check the oil level.

TO CHANGE ENGINE OIL

Determine temperature range expected before oil change. All oil must meet API service classification SG-SL.

- Be sure riding mower is on level surface.
- Oil will drain more freely when warm.
- Catch oil in a suitable container.

⚠ CAUTION: If engine has been operated for an extended period of time immediately prior to draining oil, oil will be hot.

1. Lift engine cover.
2. Remove oil fill cap/dipstick. Be careful not to allow dirt to enter the engine when changing oil.
3. Position a container to catch oil.
4. Remove drain plug and drain oil into container.
5. After oil has drained completely, replace oil drain plug and tighten securely.
6. Refill engine with oil through oil fill dipstick tube. Pour slowly. Do not overfill. For approximate capacity see "PRODUCT SPECIFICATIONS" section of this manual.
7. Use gauge on oil fill cap/dipstick for checking level. For accurate reading, tighten dipstick cap securely onto the tube before removing dipstick. Keep oil at "FULL" line on dipstick. Tighten cap onto the tube securely when finished.
8. Lower engine cover.

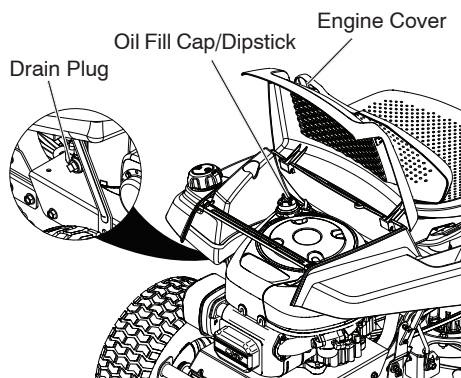

TO ADJUST STEERING WHEEL ALIGNMENT

If steering wheel crossbars are not horizontal (left to right) when wheels are positioned straight forward, remove steering wheel and reassemble per instructions in the "INSTALL STEERING COLUMN" section of this manual.

TO REMOVE WHEEL FOR REPAIRS

FRONT WHEEL

1. Block up front axle securely.
2. Remove dust cover, retaining ring, and washer to allow wheel removal.
3. Repair tire and reassemble.
4. Replace washer and retaining ring securely in axle groove.

REAR WHEEL

1. Block up rear axle securely.
2. Remove dust cover, retaining ring, washer, and square key while pulling tire off.
3. Repair tire and reassemble.
4. Replace square key while putting tire back on, then replace washer and retaining ring securely in axle groove.

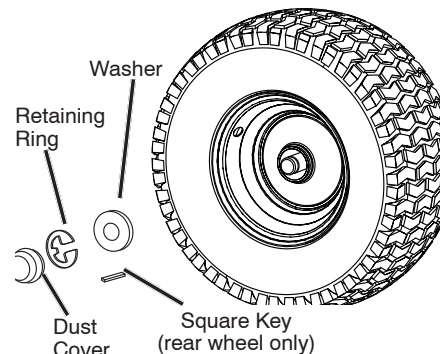

NOTE: To seal tire punctures and prevent flat tires due to slow leaks, purchase and use tire sealant from authorized service center. Tire sealant also prevents tire dry rot and corrosion.

TO START ENGINE WITH A WEAK BATTERY

⚠ CAUTION: Lead-acid batteries generate explosive gases. Keep sparks, flame and smoking materials away from batteries. Always wear eye protection when around batteries. If your battery is too weak to start the engine, it should be recharged. (See "BATTERY" in the Maintenance section of this manual).

REPLACING BATTERY

⚠ WARNING: Do not short battery terminals by allowing a wrench or any other object to contact both terminals at the same time. Before connecting battery, remove metal bracelets, wristwatch bands, rings, etc. Positive terminal must be connected first to prevent sparking from accidental grounding.

1. Lift seat pan to raised position.
2. Remove terminal cover.
3. Disconnect BLACK battery cable then RED battery cable, battery strap and carefully remove battery from riding mower.
4. Install new battery with terminals in same position as old battery.
5. Reinstall terminal cover.
6. First connect RED battery cable to positive (+) battery terminal with bolt and nut as shown. Tighten securely.
7. Connect BLACK grounding cable to negative (-) battery terminal with remaining bolt and nut. Tighten securely.
8. Lower seat pan.

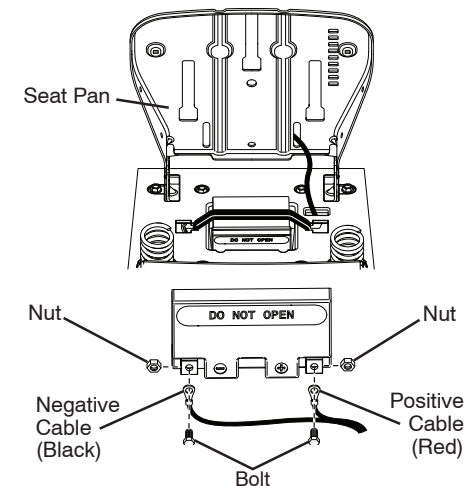

INTERLOCKS AND RELAYS

Loose or damaged wiring may cause your riding mower to run poorly, stop running, or prevent it from starting.

- Check wiring. Ensure all wiring and connectors are secure.

ENGINE

Your carburetor is not adjustable. If your engine does not operate properly due to suspected carburetor problems, take your riding mower to a qualified service center for repair and/or adjustment.

TO REPLACE MOWER BLADE DRIVE BELT

MOWER DRIVE BELT REMOVAL

1. Park riding mower on a level surface.
2. Set parking brake.
3. Lower mower to its lowest position.
4. Remove mandrel cover from mower deck.
5. Remove rear engine plate from unit.
6. Remove rear belt keeper from unit.
7. Carefully roll belt over the top of the mower blade mandrel.

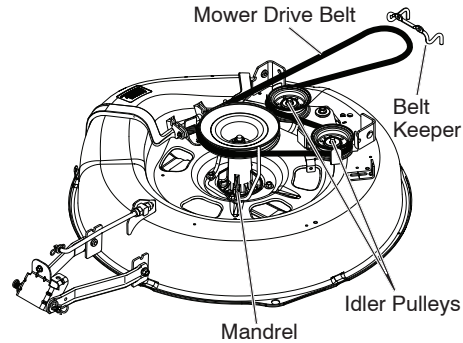

8. Remove belt from idler pulleys.
9. Check idler pulleys to see that they rotate freely.
10. Remove belt from rear drive pulley.

MOWER DRIVE BELT INSTALLATION

Install in reverse order following instructions in "MOWER DRIVE BELT REMOVAL" section.

TO CHECK BRAKE

If riding mower requires more than four (4) feet to stop at highest speed in highest gear on a level, dry concrete or paved surface, then brake must be serviced.

You may also check brake by:

1. Park riding mower on a level, dry concrete or paved surface, depress clutch/brake pedal all the way down and engage parking brake.
2. Place motion control lever in neutral position.

The rear wheels must lock and skid when you try to manually push the riding mower forward. If the rear wheels rotate, then the brake needs to be serviced. Contact a qualified service center.

TO ADJUST CLUTCH

To ensure proper drive performance, periodic adjustment of the clutch will be needed. This adjustment is only necessary when there is a reduction or loss of drive. Refer to the maintenance section in this manual for recommended intervals.

1. Park riding mower on a level surface.
2. Set parking brake.
3. Remove rear transaxle cover.
4. Using a 9/16th wrench, tighten the clutch adjustment nut by 1/8th of a turn.

CAUTION: Do not over-tighten the clutch adjustment nut. Only make as many 1/8th turns as needed.

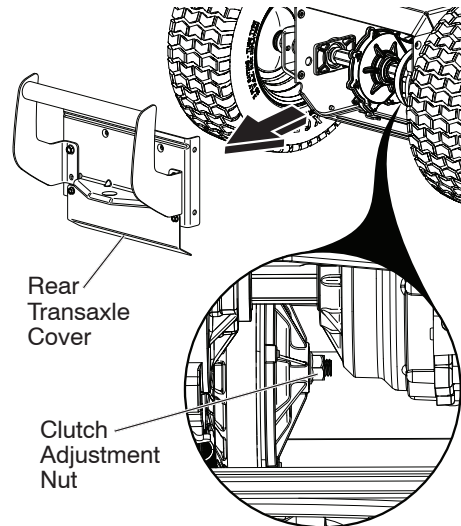

5. Test riding mower where it will be used to cut grass.
6. If further adjustment is needed, return to step 4.
7. After adjustment is completed, replace rear transaxle cover.

If the clutch adjustment procedure is not effective, take your riding mower to a qualified service center for repair and/or adjustment.

AIR FILTER

Your engine will not run properly using a dirty air filter. Service air cleaner more often under dusty conditions. See engine manual.

CLEAN AIR SCREEN

Air screen must be kept free of dirt and chaff to prevent engine damage from overheating. Clean with a wire brush or compressed air to remove dirt and stubborn dried gum fibers.

CLEAN AIR INTAKE/COOLING AREAS

To ensure proper cooling, make sure the grass screen, cooling fins, and other external surfaces of the engine are kept clean at all times.

Every 100 hours of operation (more often under extremely dusty, dirty conditions), remove the blower housing and other cooling surfaces as necessary. Clean the cooling fins and external surfaces as necessary. Ensure the cooling shrouds are reinstalled.

NOTE: Operating the engine with a blocked grass screen, dirty or plugged cooling fins, and/or cooling shrouds removed will cause engine damage due to overheating.

CLEANING FRICTION SURFACES

To ensure proper drive performance keep the friction surfaces free from dirt, chaff and excess rubber at all times.

Every 25 hours of operation, the friction surfaces need to be rubbed clean with isopropyl alcohol or other non-filming cleaner.

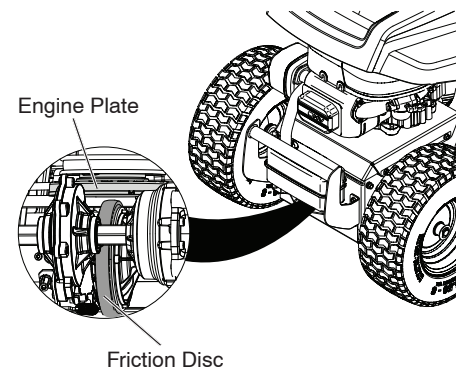

MUFFLER

Inspect and replace corroded muffler and spark arrester (if equipped) as it could create a fire hazard and/or damage.

SPARK PLUG(S)

Replace spark plug(s) at the beginning of each mowing season or after every 100 hours of operation, whichever occurs first. Spark plug type and gap setting are shown in "PRODUCT SPECIFICATIONS" section of this manual.

CLEANING

- Clean engine, battery, seat, finish, etc. of all foreign matter.
- Keep finished surfaces and wheels free of all gasoline, oil, etc.
- Protect painted surfaces with automotive type wax.

We do not recommend using a garden hose or pressure washer to clean your riding mower unless the engine and transmission are covered to keep water out. Water in engine or transmission will shorten the useful life of your riding mower. Use compressed air or a leaf blower to remove grass, leaves and trash from riding mower and mower.

SERVICE AND ADJUSTMENTS



WARNING: TO AVOID SERIOUS INJURY, BEFORE PERFORMING ANY SERVICE OR ADJUSTMENTS:

1. Depress clutch/brake pedal fully and set parking brake.
2. Place motion control lever in neutral (N) position.
3. Place deck clutch in "DISENGAGED" position.
4. Turn ignition key to "STOP" and remove key.
5. Ensure the blade and all moving parts have completely stopped.
6. Disconnect spark plug wire from spark plug and place wire where it cannot come in contact with plug.

RIDING MOWER

TO REMOVE MOWER

1. Place deck clutch in "DISENGAGED" position.
2. Move mower height adjustment lift lever forward to lower mower to its lowest position.
3. Remove mandrel cover.
4. Remove pins holding left and right front mower suspension arms in place.
5. Remove bolt holding deck front to rear leveling rod in place.

6. Remove pin holding deck lift link arm in place.
7. Remove bolt holding deck side to side leveling rod in place.
8. Remove belt from around pulleys.
9. Slide deck out from under side of mower.

TO INSTALL MOWER

Install in reverse order following instructions in "TO REMOVE MOWER" section.

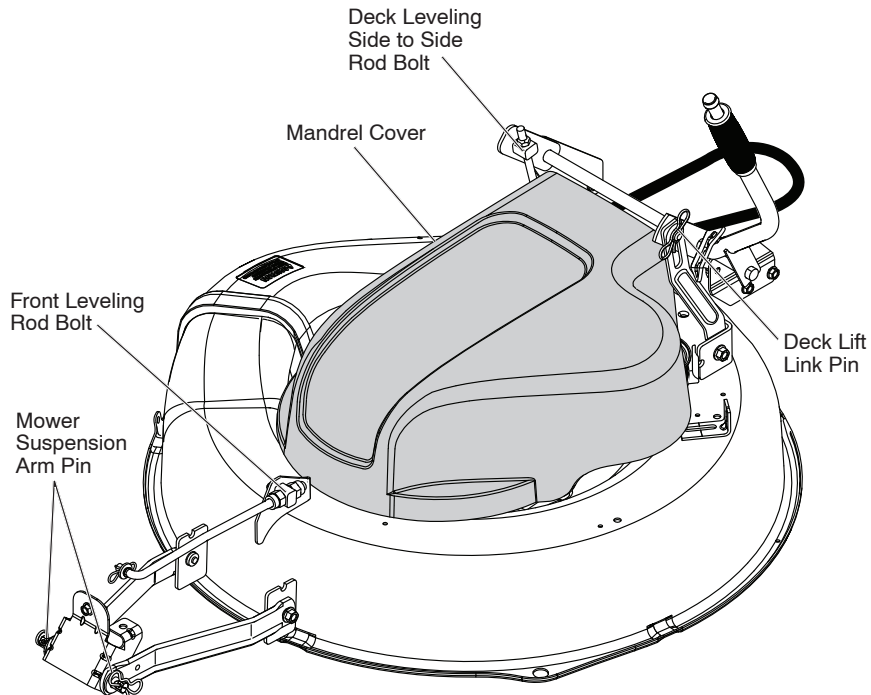

TO LEVEL MOWER HOUSING

Adjust the mower while riding mower is parked on level ground or driveway. Ensure tires are properly inflated. If tires are over or underinflated, you will not properly adjust your mower.

SIDE-TO-SIDE ADJUSTMENT

- Raise mower to its highest position.
- Measure distance "A" from bottom edge of mower to ground level at front corners of mower.

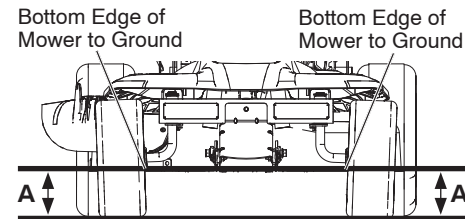

- To raise the right side of the mower, tighten lift link adjustment nut.
- To lower the right side of the mower, loosen lift link adjustment nut.

NOTE: Each full turn of adjustment nut will change mower height about 3/16".

- Recheck measurements after adjusting.

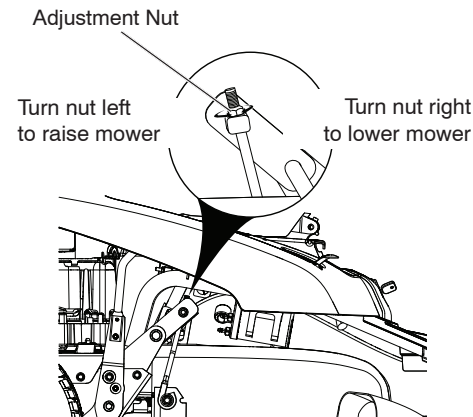

FRONT-TO-BACK ADJUSTMENT

IMPORTANT: Deck must be level side-to-side.

To obtain the best cutting results, the mower housing should be adjusted so that the front is approximately 1/8" to 1/2" lower than the rear when the mower is in its highest position.

Check adjustment on right side of riding mower. Measure distance "F" directly in front and behind the mandrel at bottom edge of mower housing as shown.

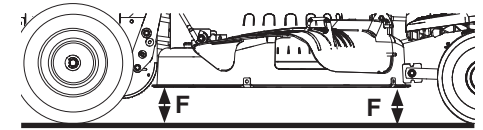

- To lower front of mower housing turn nuts "G" and "H" clockwise.
- When distance "F" is 1/8" to 1/2" lower at front than rear, tighten nut "H" against trunnion on front link.
- To raise front of mower housing turn nuts "G" and "H" counter clockwise.
- When distance "F" is 1/8" to 1/2" lower at front than rear, tighten nut "H" against trunnion on front link.

NOTE: Each full turn of "G" will change "F" by approximately about 3/8".

- Recheck side-to-side adjustment.

