

ILLUSTRATED PARTS LIST

MFG. ID NO. 96051011300

CUSTOMER CATALOG NO. M125-97TC

PRODUCT NO. 960 51 01-13

**TRACTOR - MODEL NO. M125-97TC (96051011300), PROD. NO. 960 51 01-13
DECALS 27**

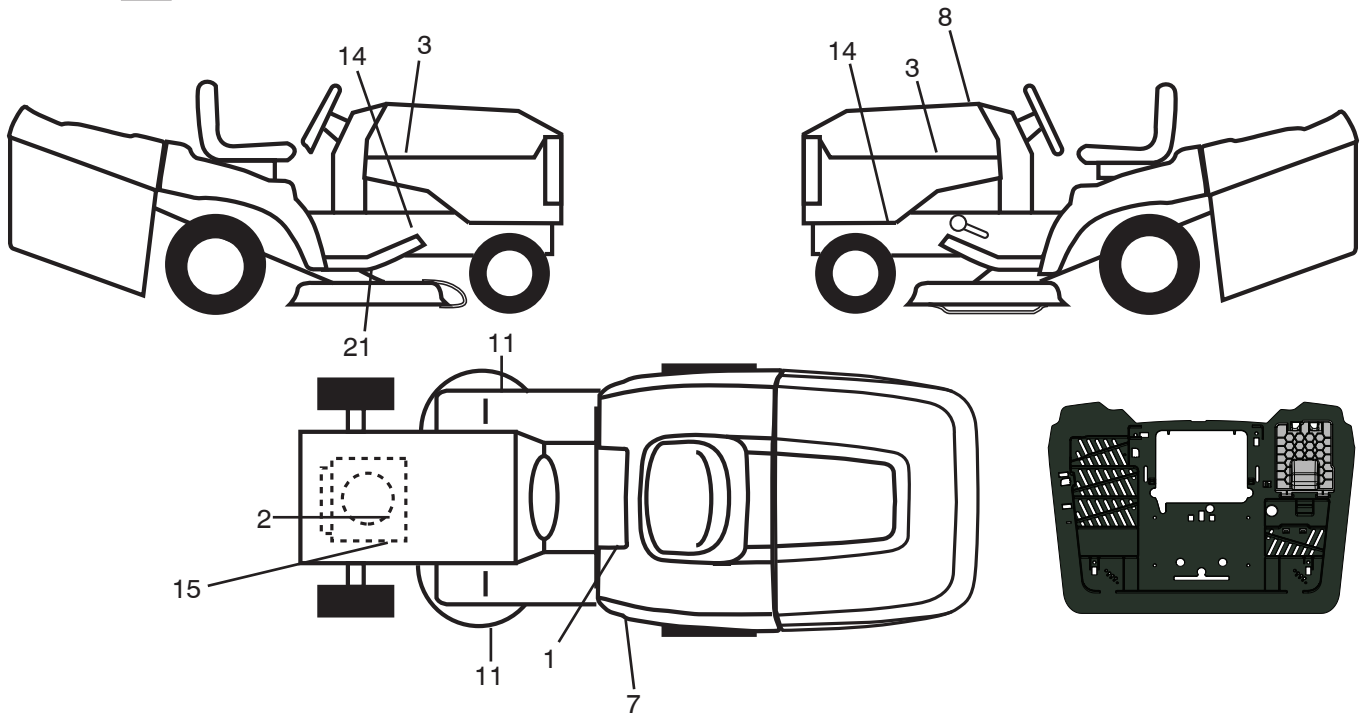

KEY NO.	PART NO.	DESCRIPTION
1	581 57 83-01	Decal, Warning
2	532 43 74-10	Decal, Warning Eng. Sym.
3	581 09 12-01	Decal, Hood RH/LH
7	581 95 02-01	Decal, Fender
8	581 75 90-01	Decal, Replacement
11	581 57 91-01	Decal, Cut Finger
14	581 57 96-01	Decal, Chassis Hot Muffler
15	581 57 97-01	Decal, Engine HP
21	532 44 11-89	Decal, Belt Sch CRD

KEY NO.	PART NO.	DESCRIPTION
--	583 90 19-01	Decal, Bypass
--	532 44 27-44	Decal, Battery Door
--	532 42 59-86	Pad Footrest RH
--	532 42 59-76	Pad Footrest LH
--	115 60 64-20	Manual Operator's (Euro)
--	115 60 64-10	Manual Operator's (Scan)
--	115 60 64-50	Manual Operator's (E-Bloc)
--	115 60 64-40	Manual Operator's (Baltic)

WHEELS & TIRES

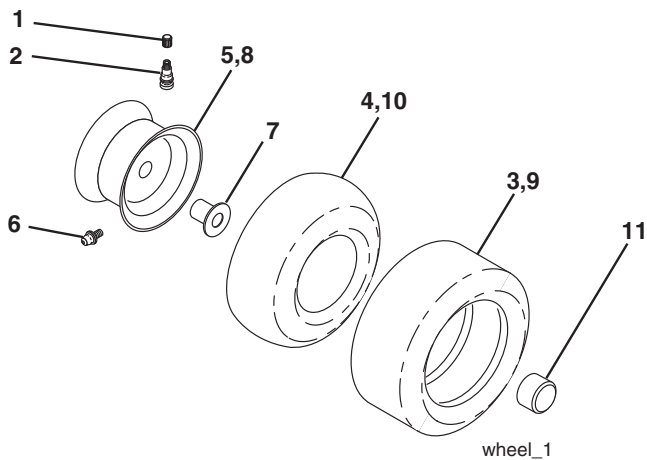

KEY NO.	PART NO.	DESCRIPTION
1	532 05 91-92	Cap Valve Tire
2	532 06 51-39	Stem Valve
3	532 10 62-22	Tire F Ts 15 x 6 0 - 6 Service
4	532 05 99-04	Tube Inner Front #35060
5	532 12 51-21	Rim Asm 6" Front Silver Service
6	532 12 49-57	Fitting Grease
7	532 12 49-59	Bearing Flange
8	532 12 51-22	Rim Asm 8" Rear Silver Service
9	532 42 05-31	Tire R.Ts-LT 18 x 9.5-8 C Ser.
10	532 12 49-26	Tube Rear 9 5 x 8 Service
11	532 19 32-68	Cap Axle
--	532 14 43-34	Sealant, Tire (10 oz. Tube)

NOTE: All component dimensions given in U.S. inches
1 inch = 25.4 mm

TRACTOR - MODEL NO. M125-97TC (96051011300), PROD. NO. 960 51 01-13

SCHEMATIC 38

SCH17

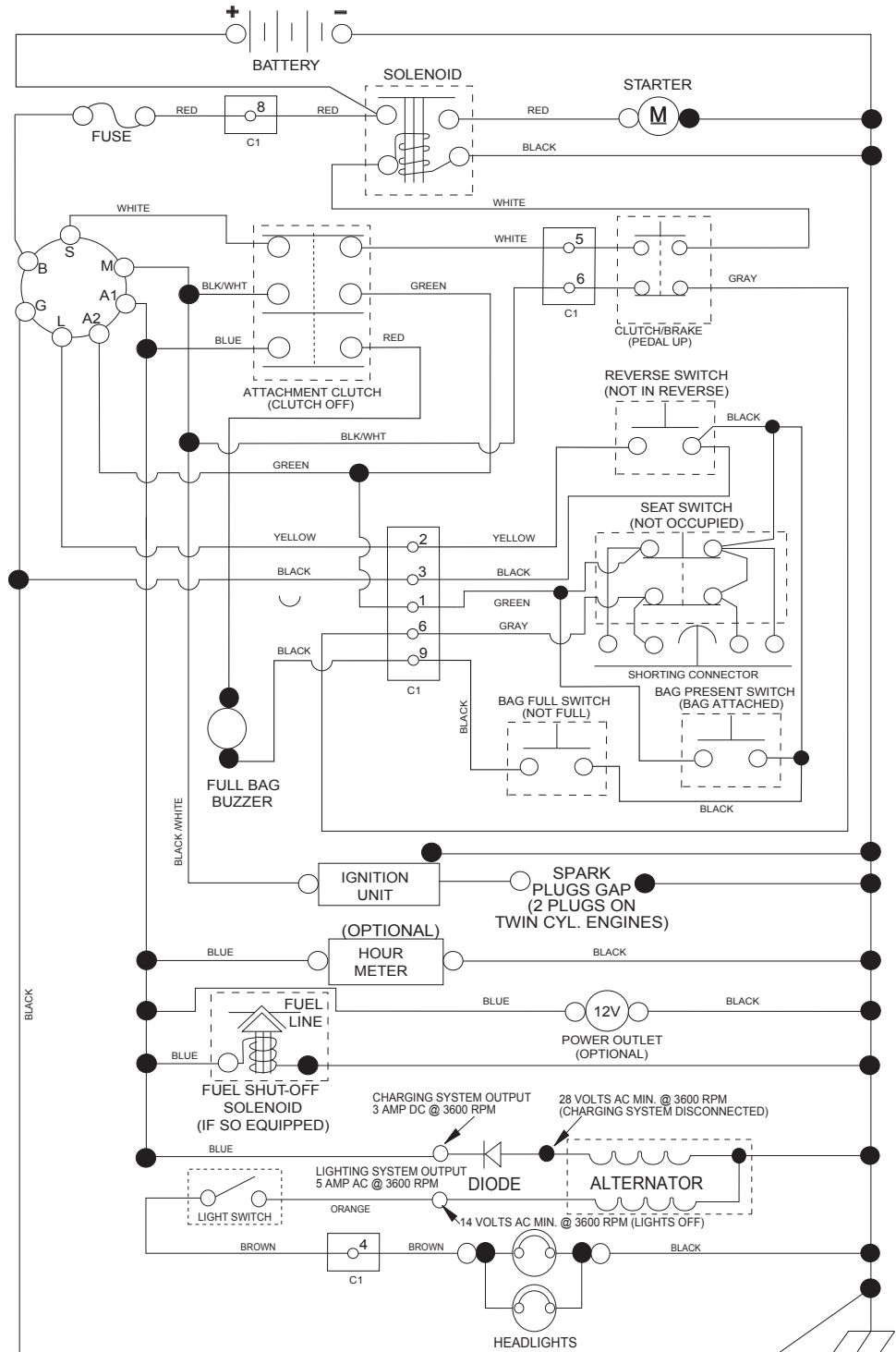

NOTE
YOUR TRACTOR IS EQUIPPED WITH A SPECIAL ALTERNATOR SYSTEM. THE LIGHTS ARE NOT CONNECTED TO THE BATTERY, BUT HAVE THEIR OWN ELECTRICAL SOURCE. BECAUSE OF THIS, THE BRIGHTNESS OF THE LIGHTS WILL CHANGE WITH ENGINE SPEED. AT IDLE THE LIGHTS WILL DIM. AS THE ENGINE SPEED IS INCREASED, THE LIGHTS WILL BECOME THEIR BRIGHTEST.



IGNITION SWITCH

POSITION	CIRCUIT	"MAKE"
OFF	M+G+A1	
RUN/OVERRIDE	B+A1	
RUN	B+A1	L+A2
START	B + S + A1	



CHASSIS HARNESS CONNECTOR (C1) (MATING SIDE)



DASH HARNESS CONNECTOR (C1) (MATING SIDE)

WIRING INSULATED CLIPS
NOTE: IF WIRING INSULATED CLIPS WERE REMOVED FOR SERVICING OF UNIT, THEY SHOULD BE RE-INSTALLED TO PROPERLY SECURE YOUR WIRING.

● NON-REMOVABLE CONNECTIONS
○ REMOVABLE CONNECTIONS

TRACTOR - MODEL NO. M125-97TC (96051011300), PROD. NO. 960 51 01-13
ELECTRICAL 32

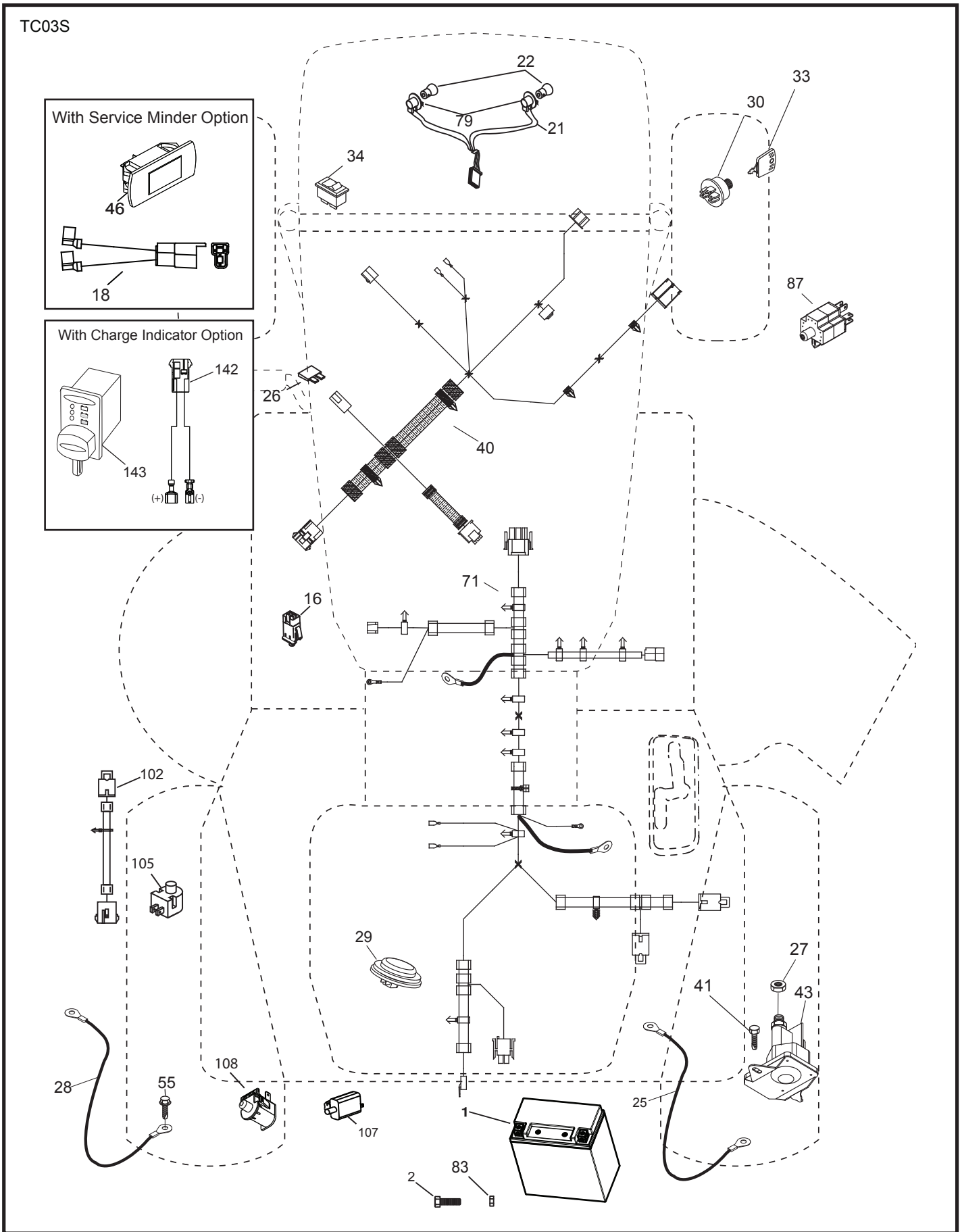

**TRACTOR - MODEL NO. M125-97TC (96051011300), PROD. NO. 960 51 01-13
ELECTRICAL 32**

KEY NO.	PART NO.	DESCRIPTION
1	532 43 71-57	Battery
2	532 44 09-23	Screw Hex Hd Cap M6 x 1.12mm
16	532 17 61-38	Switch Interlock
21	532 40 02-52	Harness Asm Light w/4152J
22	532 00 41-52	Bulb Light #1156
25	581 48 98-01	Cable Battery Red
26	532 17 51-58	Fuse
27	873 51 04-00	Nut Keps Hex 1/4-20 unc
28	581 48 98-02	Cable Ground Black
29	532 40 15-45	Switch Seat
30	532 19 33-50	Switch Ignition
33	532 41 19-35	Key/Chain
34	532 11 07-12	Switch Light
40	532 42 10-02	Harness Ignition Dash
41	817 72 04-08	Screw 1/4-20 x 1/2
43	532 19 25-07	Solenoid
55	817 06 05-12	Screw 5/16-18 x 3/4
71	581 02 33-01	Harness Chassis
79	532 17 52-42	Socket Asm.
83	532 43 67-74	Nut Square M6 x 1 x 8.5 x 11mm
87	532 42 10-60	Switch Railmount
102	581 02 35-01	Harness Pigtail
105	532 40 75-68	Switch Reverse
107	532 18 03-79	Switch Full Bagger Indicator
108	532 42 10-62	Switch Snapmount

NOTE: All component dimensions given in U.S. inches
1 inch = 25.4 mm

TRACTOR - MODEL NO. M125-97TC (96051011300), PROD. NO. 960 51 01-13
CHASSIS AND ENCLOSURES **39**

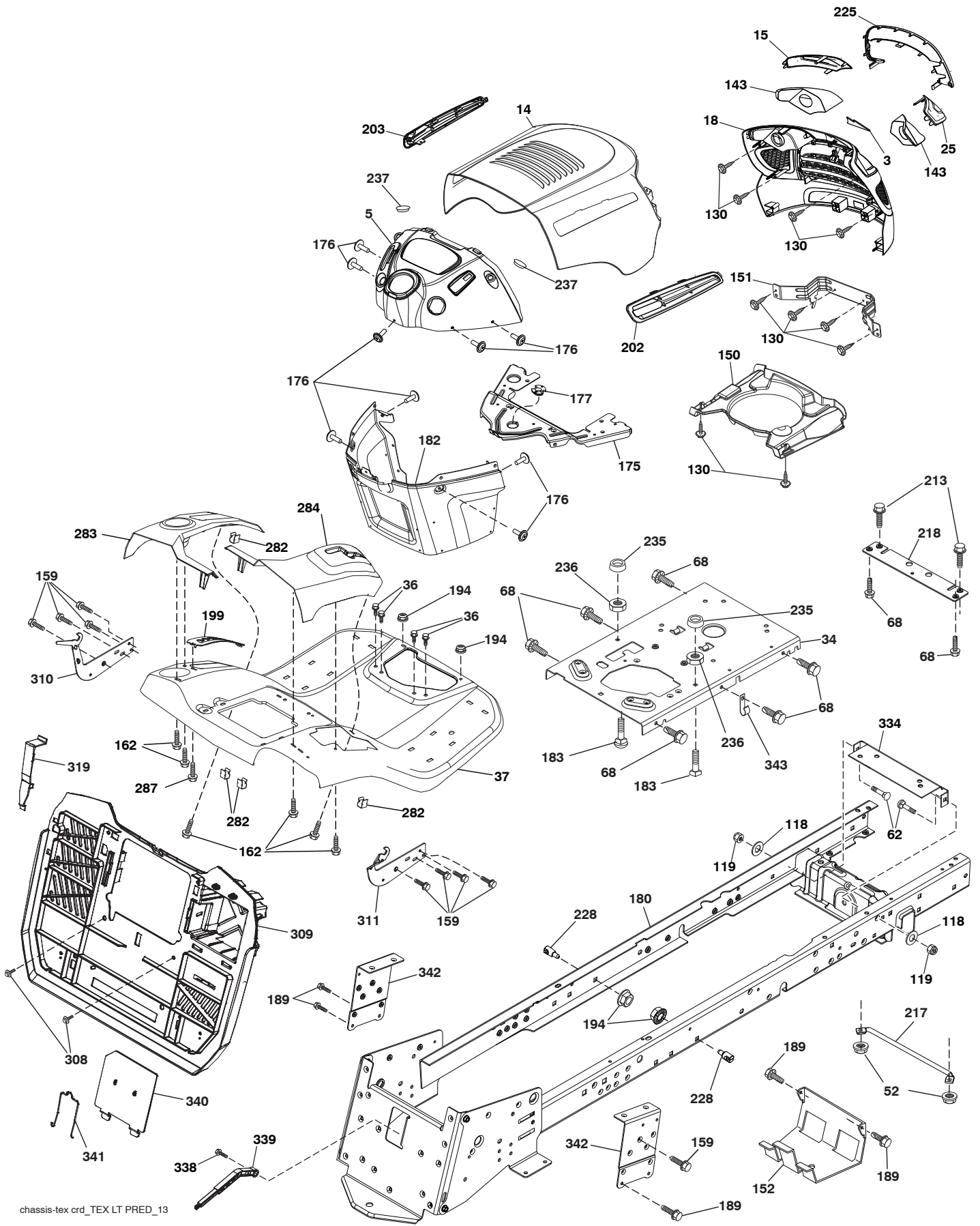

chassis-tex crd_TEX LT PRED_13

**TRACTOR - MODEL NO. M125-97TC (96051011300), PROD. NO. 960 51 01-13
CHASSIS AND ENCLOSURES 39**

KEY NO.	PART NO.	DESCRIPTION	KEY NO.	PART NO.	DESCRIPTION
3	578 89 71-01	Emblem Mount	203	581 56 48-01	Vent Hood LH
5	532 40 95-97	Dash	213	874 76 05-12	Bolt 5/16-18 x 3/4
14	581 56 47-01	Hood	217	532 40 91-67	Rod Pivot Hood
15	581 05 58-01	Lens LH	218	532 19 63-95	X-Piece Hood Stop
18	581 05 57-01	Grille	225	581 05 62-01	Trim Ring
25	581 05 59-01	Lens RH	228	532 19 51-61	Stud Fastener
34	580 91 09-01	Plate Engine	235	532 40 61-29	Spacer Fender
36	817 06 05-12	Screw 5/16-18 x 3/4	236	873 93 05-00	Nut Lock 5/16-18 unc
37	532 43 96-24	Fender	237	532 40 37-04	Plug Mount Cargo
52	873 68 05-00	Nut Crown Lock 5/16	282	532 41 41-10	Clip Retainer
62	872 11 06-08	Bolt 3/8-16 x 1 Gr. 5	283	532 44 03-61	Console Deck Lift
68	817 49 05-08	Screw Thdrol. 5/16-18 x 1/2	284	532 44 03-60	Console Shift RH
118	819 13 13-16	Washer 13/32 x 13/16 x 16 Ga.	287	817 60 04-06	Screw Hex Washead 1/4-20 x 3/8
119	873 68 06-00	Nut 3/8-16 unc	308	532 17 18-77	Bolt 5/16-18 unc x 3/4
130	532 41 63-58	Screw #10 x 0.750 BOS Thread	309	584 44 11-01	Backplate Bagger
143	581 05 60-01	Insert Reflective RH/LH	310	532 44 66-36	Hanger LH
150	532 40 02-67	Duct, Air	311	532 44 66-37	Hanger RH
151	532 18 75-68	Bracket Pivot Hood	319	532 17 46-62	Bracket
152	532 19 95-35	Shield Browning	334	532 44 25-37	Engine Plate
159	817 00 06-12	Screw Hexwsh Thdr 3/8-16 x 3/4	338	532 43 66-40	Bolt Shoulder
162	532 14 24-32	Screw Hex Wsh. Hi-Lo 1/4 x 1/2 unc	339	532 43 66-41	Lever Bagger Full
175	532 19 94-72	Crossmember	340	532 44 09-31	Door Battery
176	532 40 07-76	Screw 10-24 x 5/8	341	532 43 66-38	Latch Battery Door
177	532 19 52-28	Bushing Steering	342	532 43 59-38	Support Fender
180	583 90 28-01	Chassis	343	532 44 07-49	Clip
182	532 40 71-76	Dash Lower			
183	874 52 05-20	Bolt 5/16-18 x 1-1/4			
189	817 00 05-12	Screw 5/16-18 x 3/4			
194	873 90 05-00	Nut Lock Hex Flange 5/16-18			
199	532 41 87-39	Plate Deck Lift			
202	581 56 49-01	Vent Hood RH			

NOTE: All component dimensions given in U.S. inches
1 inch = 25.4 mm

TRACTOR - MODEL NO. M125-97TC (96051011300), PROD. NO. 960 51 01-13
DRIVE **40**

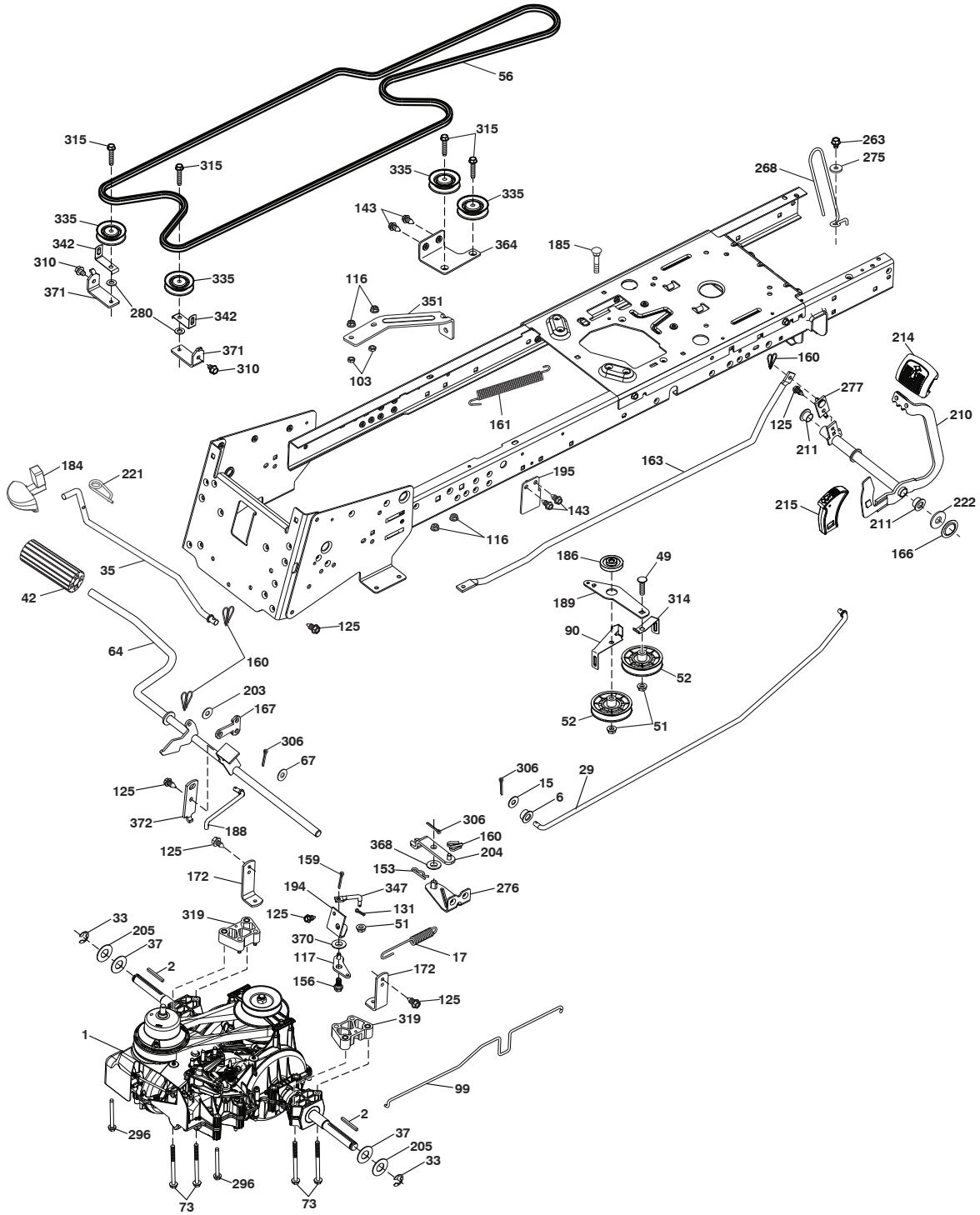

drive-CRD_VATR_PEDAL_17

**TRACTOR - MODEL NO. M125-97TC (96051011300), PROD. NO. 960 51 01-13
DRIVE **40****

KEY NO.	PART NO.	DESCRIPTION	KEY NO.	PART NO.	DESCRIPTION
1	---	Transmission, Gentrans VATR. (580486401) (Order parts from transaxle manufacturer.)	188	532 19 43-23	Link Clutch Ground Drive
2	532 12 35-83	Key Square .2.0 x .1845/.1865	189	532 43 36-11	Bellcrank Groundrive
6	532 12 40-28	Bushing Snap	194	583 87 86-01	Bellcrank Brake
15	819 13 13-16	Washer 13/32 x 13/16 x 16 Ga.	195	580 45 69-02	Brake Bracket
17	580 32 52-01	Spring Brake	203	819 11 11-16	Washer 11/32 x 11/16 x 16 Ga.
29	581 18 74-01	Rod Brake	204	584 13 81-02	Link Pivot Pedal
33	812 00 00-01	E-Ring. #5133-75	205	532 12 17-48	Washer 25/32 x 1-5/8 x 16 Ga.
35	532 40 10-31	Rod Brake Parking	210	532 44 82-70	Weldment Pedal
37	532 18 89-67	Washer Harden .793 x 1.637 x 060	211	532 12 01-83	Bearing Nylon
42	532 12 48-72	Cover Pedal Blk Round	214	532 42 12-63	Pedal Forward Pad
49	872 11 06-14	Bolt Rdhd 3/8-16 Unc x 1-3/4. Gr 5	215	532 44 82-54	Cap Pedal Reverse
51	873 90 06-00	Nut, Hex, Flangelock 3/8-16	221	532 40 31-87	Retainer Spring Clip Handle
52	532 19 43-26	Idler V-Groove Offset	222	879 21 20-10	Washer 21/32 x 1-1/4 10 Ga.
56	532 44 69-91	Belt Drive	263	817 00 06-12	Screw
64	532 44 83-53	Shaft Asm. Pedal Brake	268	532 18 24-02	Guard Muffler
67	819 13 13-12	Washer 13/32 x 13/16 x 12 Ga.	275	819 13 16-14	Washer
73	580 83 04-01	Bolt Shoulder Transaxle	276	584 99 67-01	Bracket Control Pedal
90	532 44 36-05	Keeper Belt	277	532 44 85-00	Subasm. Link Rocker Pedal
99	581 28 09-01	Rod Bypass	280	819 11 10-12	Washer 11/32 x 5/8 x 12 Ga.
103	873 35 05-00	Nut Hex Jam 5/16-18 UNC	296	532 42 04-71	Screw Thdrol 5/16-18 x 3
116	873 90 05-00	Nut, Lock Hex Flange 5/16-18 unc	306	876 02 04-16	Pin Cotter 1/8 x 1
117	580 38 29-01	Subasm Bellcrank Brake	310	817 49 06-08	Screw Thdrol 3/8-16 x 1/2
125	817 00 05-12	Screw 5/16-18 x 3/4 Smgml Tap/Bl	311	584 07 20-01	Washer Nylon
131	876 02 03-08	Pin Cotter 3/32 x 1/2	314	532 44 47-13	Keeper Belt
143	817 49 05-08	Screw Thdrol 5/16-18 x 1/2 Tytt	315	817 58 05-20	Screw Thdrol 5/16-18 x 1.25
153	532 12 49-61	Retainer Clip	319	580 45 74-01	Spacer Transaxle
156	580 36 90-01	Bolt Shoulder Brake	335	532 19 95-34	Pulley V-Idler
159	876 02 04-12	Pin Cotter 1/8 x 3/4	342	580 96 10-02	Keeper Belt Idler
160	532 16 94-84	Retainer Clip(M).Dia.290	347	580 32 51-01	Rod Connecting Brake
161	532 10 57-09	Spring Return Clutch 6.75	351	532 43 69-98	Bracket Swaybar
163	581 18 73-01	Rod Control Pedal	364	532 44 30-32	Bracket Idler
166	532 42 91-64	Nut Push .625	368	819 17 19-12	Washer 17/32 x 1-3/16 x 1/2
167	532 40 52-57	Latch Brake Parking	370	878 12 16-32	Washer Thrust 3/8 x 1 x .032
172	532 44 82-76	Strap Torque LH/RH	371	580 96 07-02	Bracket Idler
184	532 44 14-07	Handle Parking Brake	372	585 21 76-01	Arm Control Brake
185	872 11 06-22	Bolt Rdhd.3/8-16 Unc x 2-3/4 Gr.5			
186	532 19 43-21	Spacer Retainer			

NOTE: All component dimensions given in U.S. inches
1 inch = 25.4 mm

**TRACTOR - MODEL NO. M125-97TC (96051011300), PROD. NO. 960 51 01-13
ENGINE 24**

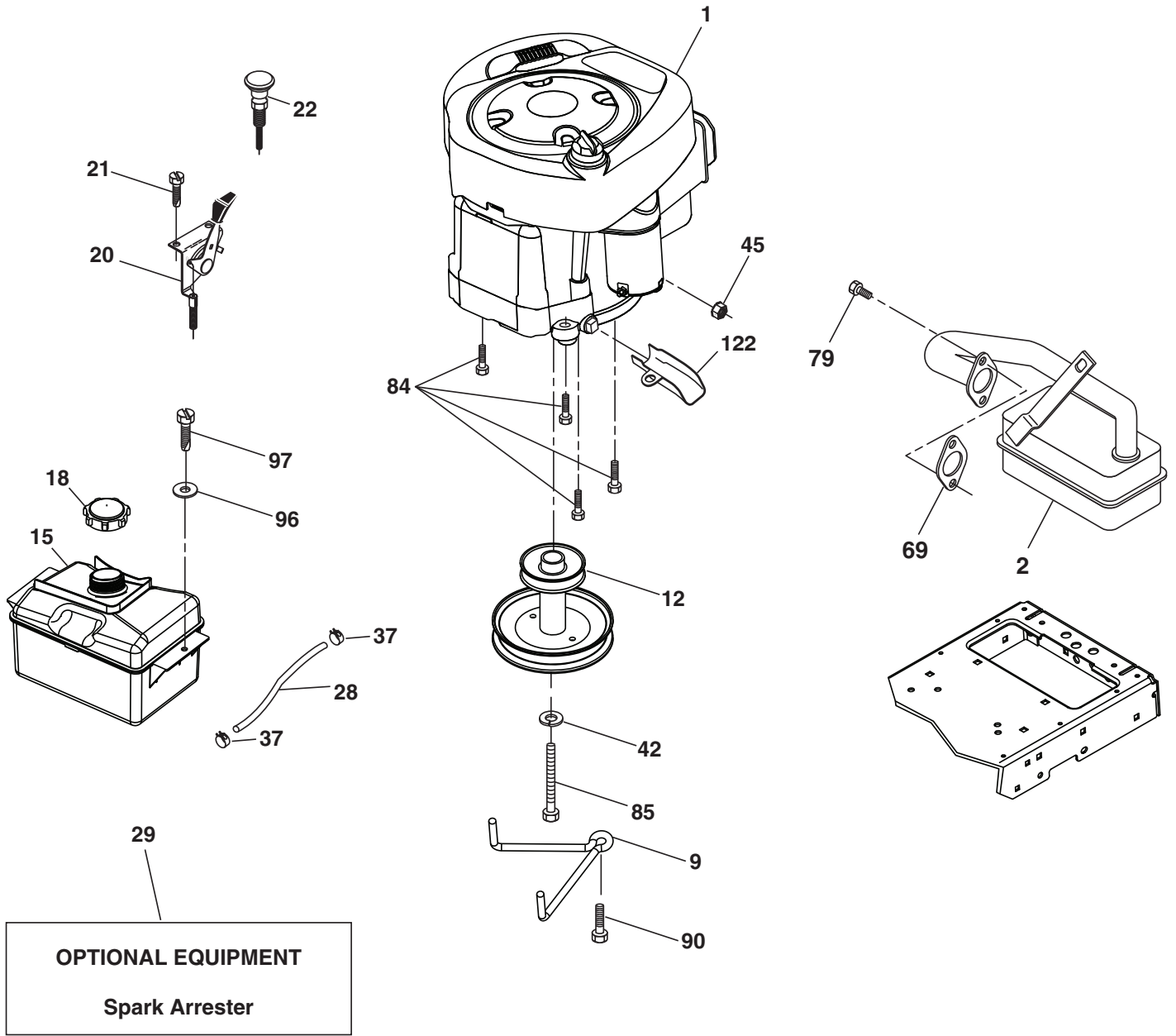

engine-tex_BS_79

**TRACTOR - MODEL NO. M125-97TC (96051011300), PROD. NO. 960 51 01-13
ENGINE 24**

KEY NO.	PART NO.	DESCRIPTION
1	— — — — —	Engine Briggs Model 219807-3402-B1 (438614) (Order parts from engine manufacturer.)
2	532 17 97-58	Muffler
9	583 84 78-01	Keeper Belt Engine
12	532 40 54-71	Pulley Engine
15	581 28 99-01	Tank Fuel
18	532 43 02-20	Cap Fuel
20	532 18 38-97	Control Throttle/Choke
21	532 41 63-58	Screw #10 x 0.750
22	532 19 49-81	Control Choke
28	532 13 70-40	Line Fuel
29	532 13 71-80	Kit Spark Arrester (Flat Scrn)
37	532 12 34-87	Clamp Hose Blk
42	810 04 07-00	Washer Lock 7/16
45	873 51-04-00	Nut Keps Hex 1/4-20 unc
69	532 16 52-91	Gasket Muffler
79	532 19 23-34	Screw 5/16-18 x .75
84	817 06 06-20	Screw 3/8-16 x 1-1/4
85	532 17 39-37	Bolt 7/16-20 x 4 x Gr. 5-1.5 THR
90	817 00 06-16	Screw 3/8-16 x 1
96	819 09 14-16	Washer 9/32 x 7/8 x 16 Ga.
97	817 67 04-12	Screw Hexwsh Thdrol 1/4-20 x 3/4
122	532 42 19-22	Extension Drain Oil

NOTE: All component dimensions given in U.S. inches
1 inch = 25.4 mm

Engine Power Rating Information

The gross power rating for individual gas engine models is labeled in accordance with SAE (Society of Automotive Engineers) code J1940 (Small Engine Power & Torque Rating Procedure), and rating performance has been obtained and corrected in accordance with SAE J1995 (Revision 2002-05). Torque values are derived at 3060 RPM; horsepower values are derived at 3600 RPM. Actual gross engine power will be lower and is affected by, among other things, ambient operating conditions and engine-to-engine variability. Given both the wide array of products on which engines are placed and the variety of environmental issues applicable to operating the equipment, the gas engine will not develop the rated gross power when used in a given piece of power equipment (actual “on-site” or net power). This difference is due to a variety of factors including, but not limited to, accessories (air cleaner, exhaust, charging, cooling, carburetor, fuel pump, etc.), application limitations, ambient operating conditions (temperature, humidity, altitude), and engine-to-engine variability. Due to manufacturing and capacity limitations, Briggs & Stratton may substitute an engine of higher rated power for this Series engine.

TRACTOR - MODEL NO. M125-97TC (96051011300), PROD. NO. 960 51 01-13
STEERING ASSEMBLY **41**

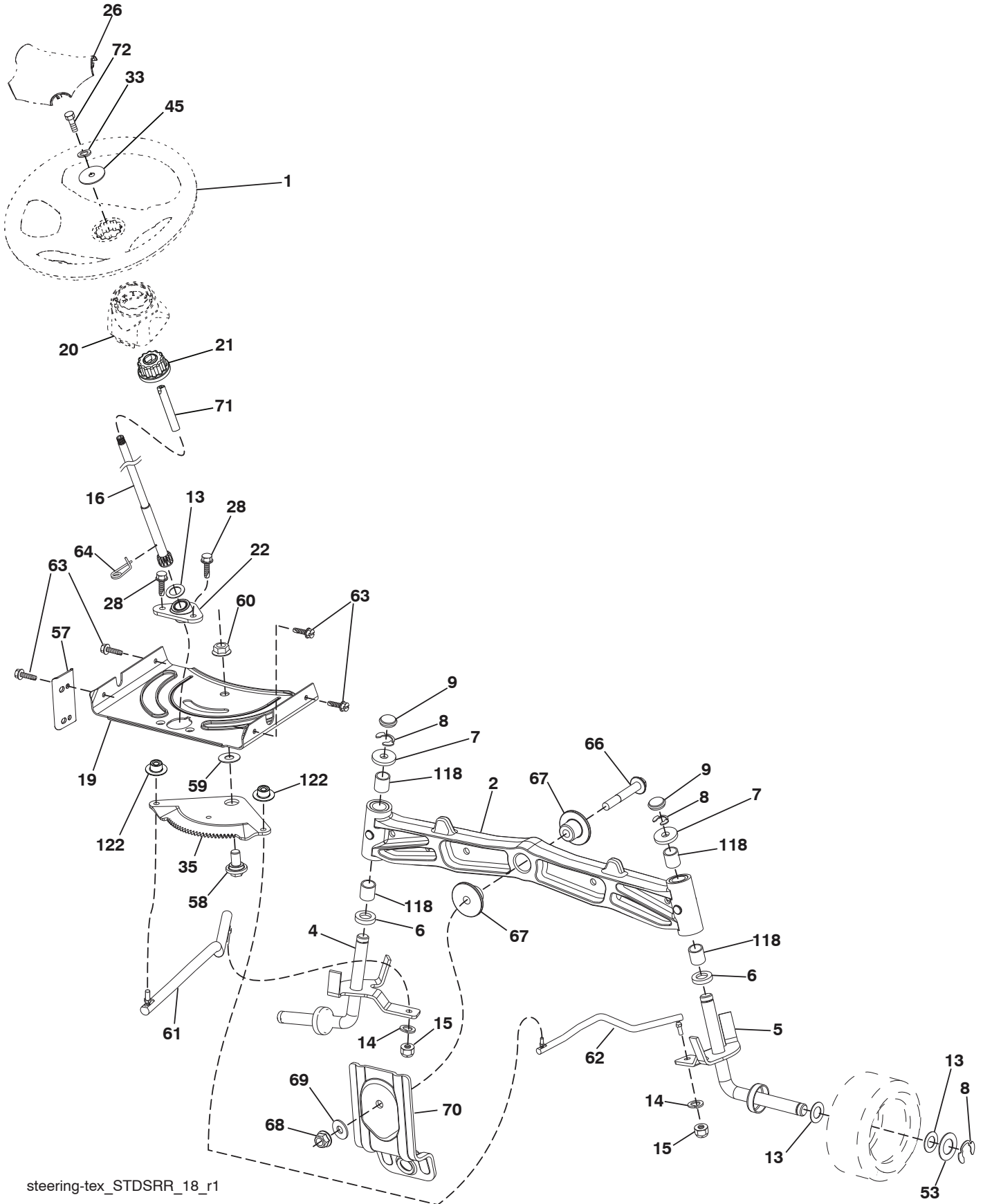

steering-tex_STDSRR_18_r1

TRACTOR - MODEL NO. M125-97TC (96051011300), PROD. NO. 960 51 01-13
STEERING ASSEMBLY 41

KEY NO.	PART NO.	DESCRIPTION
1	532 44 28-04	Wheel, Steering
2	532 41 35-91	Axle Asm., Front
4	532 40 30-87	Spindle Asm., LH
5	532 40 30-88	Spindle Asm., RH
6	532 12 49-31	Bearing, Race Thrust Harden
7	532 12 17-48	Washer 25/32 x 1-5/8 x 16 Ga.
8	812 00 00-29	Ring, Klip #T5304-75
9	532 12 12-32	Cap, Spindle
13	532 12 17-49	Washer 25/32 x 1-1/4 x 16 Ga.
14	810 04 06-00	Washer, Lock Hvy Hlcl Spr 3/8
15	873 54 06-00	Nut, Crown Lock 3/8-24 unf
16	532 42 93-73	Shaft Steering
19	532 19 47-29	Plate Steering
20	532 40 97-63	Boot, Steering
21	532 18 67-37	Adapter, Wheel Steering
22	532 42 05-37	Strg. Supt. Lower
26	532 44 77-59	Insert, Wheel Steering
28	817 00 06-12	Screw 3/8-16 x 3/4
33	810 04 05-00	Washer Lock 5/16
35	532 19 47-32	Gear, Sector Plate
45	819 11 38-12	Washer 11/32 x 3/8 x 12 Ga.
53	532 18 89-67	Washer Hardened .793 x 1.637 x .060
57	532 40 74-65	Bracket Upstop
58	532 19 47-47	Bolt Shoulder Sector Pivot CFM
59	532 19 47-48	Washer Thrust Sector Steering
60	873 97 10-00	Nut Flange Lock 5/8-11
61	532 19 47-40	Draglink, LH
62	532 19 47-41	Draglink, RH
63	817 00 05-12	Screw 5/16-18 x 3/4
64	532 19 98-49	Retainer Clip Spring Steering
66	871 02 07-48	Bolt Hex Fghd 7/16-14 x 3 Serr
67	532 19 47-37	Bushing PM Front Axle
68	873 90 07-00	Nut Lock Flange 7/16-14 Gr. 5
69	532 19 91-62	Washer 1.5 x .505 x .118
70	532 19 61-97	Bracket Deck Susp. Front
71	532 19 07-52	Shaft Extension Steering
72	532 42 89-82	Bolt Fin Hx 5/16-18 x 4
118	532 40 60-13	Bushing
122	532 44 49-62	Cap Gear Sector

NOTE: All component dimensions given in U.S. inches
1 inch = 25.4 mm

TRACTOR - MODEL NO. M125-97TC (96051011300), PROD. NO. 960 51 01-13
MOWER DECK 44

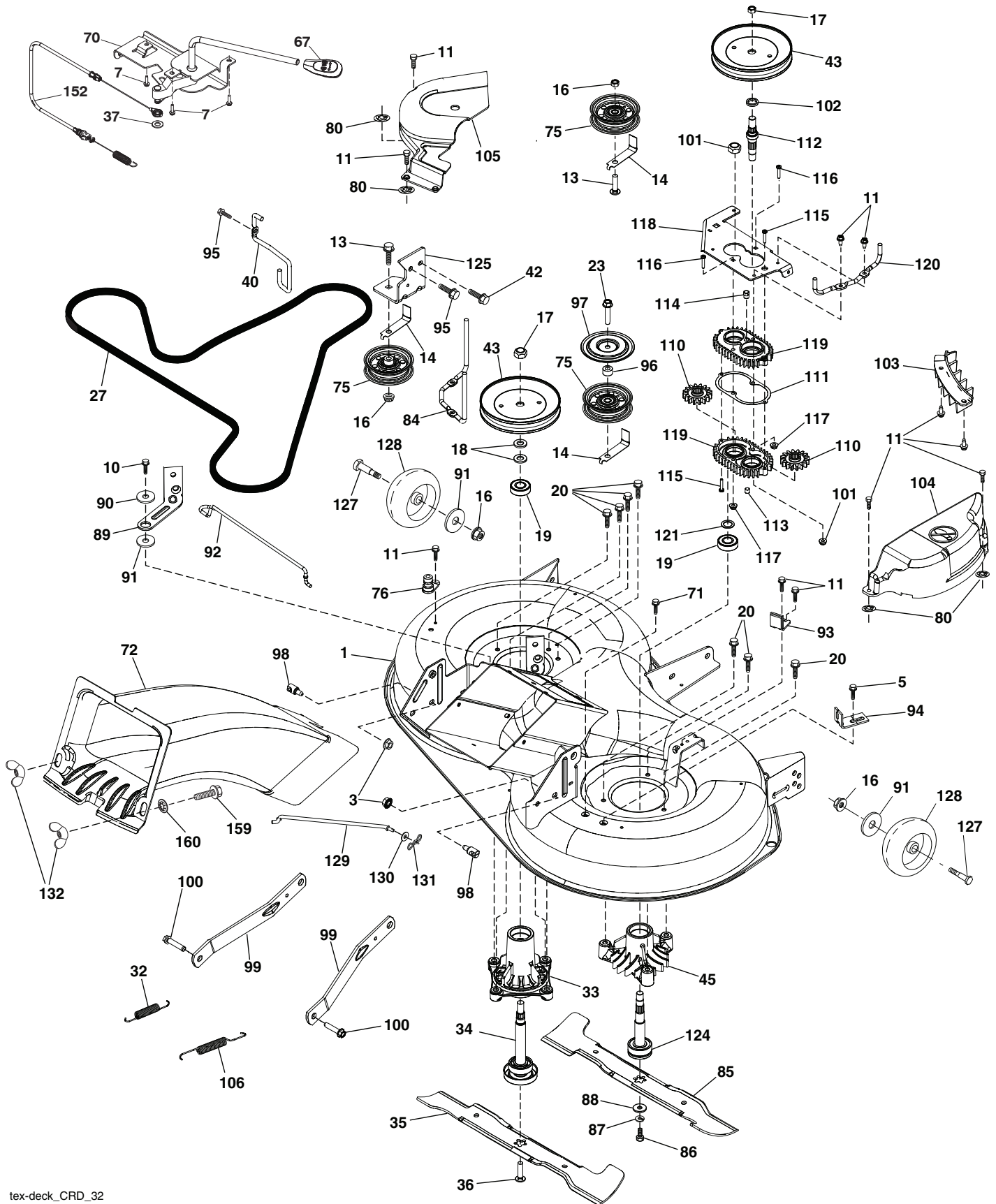

tex-deck_CRD_32

TRACTOR - MODEL NO. M125-97TC (96051011300), PROD. NO. 960 51 01-13
MOWER DECK 44

KEY NO.	PART NO.	DESCRIPTION	KEY NO.	PART NO.	DESCRIPTION
1	532 43 69-70	Deck Weldment	97	532 18 20-61	Shield Idler Mower
3	873 90 05-00	Nut Lock Hex Flange 5/16 - 18	98	532 19 51-61	Stud Fastener
5	817 00 05-10	Bolt 5/16-18	99	532 19 51-86	Arm Suspension Mower Rear
7	532 41 63-58	Screw #10 x 0.750 BOS Thread	100	532 19 65-39	Bolt Shoulder
10	817 00 06-16	Screw 3/8-16x1 smgml tap	101	873 68 09-00	Nut Crownlock 9/16 - 18 unc
11	532 13 77-29	Screw Thd Roll 1/4 - 20 X 5/8	102	532 40 25-11	Spacer Bearing Swing Plate
13	872 11 06-12	Bolt Carr Sh 3/8 - 16 X 1 - 1/2 Gr. 5	103	532 43 69-92	Guard Front Vent
14	532 15 60-85	Keeper Belt Idler	104	532 44 14-79	Mandrel Cover RH
16	873 90 06-00	Nut Lock FIG 3/8 - 16 unc	105	532 44 14-78	Mandrel Cover LH
17	532 40 02-34	Nut Flange Lock Top	106	532 19 32-16	Spring Brake Return
18	532 18 76-90	Washer Spacer Mandrel	110	532 41 53-56	Gear Output
19	532 11 04-85	Bearing Ball Mandrel	111	532 43 69-79	Gasket Gearcase
20	532 17 39-84	Screw Thread Roll	112	532 44 38-52	Shaft Gearcase
23	817 49 06-28	Screw Thdrol 3/8 - 16 X 1-3/4	113	532 43 85-33	Plug Oil
27	532 43 97-26	V-Belt Drive	114	532 43 85-34	Valve Relief
32	532 40 18-72	Spring Return Deck	115	818 03 10-16	Screw Torx #10-24 x 1
33	532 18 72-81	Housing Mandrel 4pt Service	116	872 11 04-14	Bolt 1/4-20 x 1.75 Gr. 5
34	532 19 28-72	Shaft Asm Mndrl N/Greaseable38	117	873 90 04-00	Nut Hex Flange 1/4-20 unc
35	532 42 79-84	Blade Mower LH	118	532 43 69-89	Arm Clutching
36	532 19 30-03	Bolt/Washer Asm 7/16 - 20 unf	119	532 43 81-66	Gearcase Subasm
37	819 13 13-16	Washer 13/32 x 13/16 x 16 Ga.	120	532 43 69-91	Keeper Belt RH
40	532 19 72-58	Keeper Belt Engine LH	121	532 43 69-85	Washer
42	817 00 05-12	Screw 5/16-18 x 3/4	124	532 43 69-86	Non Greasable Mandrel Shaft
43	532 19 74-73	Pulley Mandrel	125	532 44 04-20	Bracket Idler Chasses
45	532 13 71-52	Housing Mandrel	127	532 19 34-06	Bolt Shoulder 3/8-16 x 3-5/8 Gr. 5
67	532 40 30-12	Handle Clutch Cable	128	532 17 48-73	Wheel Guage
70	532 40 12-46	Clutch Asm Manual LT Pred	129	532 40 48-51	Rod Anti-Sway
71	817 67 06-08	Screw Thdrol 3/8-16 x 1/2	130	819 13 13-12	Washer 13/32 x 13/16 x 12 Ga.
72	532 44 68-10	Chute Upper	131	532 19 42-08	Pin Cotter 5/16 Bow Tie Lock
75	532 13 14-94	Pulley Idler Flat	132	532 17 88-99	Knob Handle
76	532 41 55-98	Washout Port	152	532 44 04-88	Cable Clutch Manual w/Spring
80	532 42 30-62	Palnut	159	872 14 06-14	Bolt 3/8-16 unc
84	532 43 25-20	Keeper Belt LH Mandrel	160	532 16 89-37	Nut Push
85	532 42 79-85	Blade Mower RH	--	532 19 28-70	Mandrel Assembly (Includes Housing (key#33), Shaft Assembly (key#34), And Bearing Only (key#19) - Pulley/Nut/Washer And Blade Bolt/Washers Not Included)
86	532 18 17-13	Bolt 3/8-24 x 1.50 Gr. 8			
87	810 03 06-00	Washer Lock Hvy 3/8			
88	532 14 02-96	Washer Hard Blade Mower Vented			
89	532 43 81-24	Arm Brake 97 LH			
90	532 19 90-92	Spacer Retainer	--	532 44 82-19	Replacement Mower Complete
91	819 13 20-12	Washer 13/32 x 1-1/4 x 12 Ga.			
92	532 43 69-93	Rod Brake			
93	532 43 81-25	Arm Brake RH			
94	532 19 72-50	Bracket Clutch Cable			
95	817 00 06-12	Screw 3/8-16 x 3/4			
96	532 40 02-71	Spacer			

NOTE: All component dimensions given in U.S. inches
1 inch = 25.4 mm

TRACTOR - MODEL NO. M125-97TC (96051011300), PROD. NO. 960 51 01-13
MOWER LIFT 45

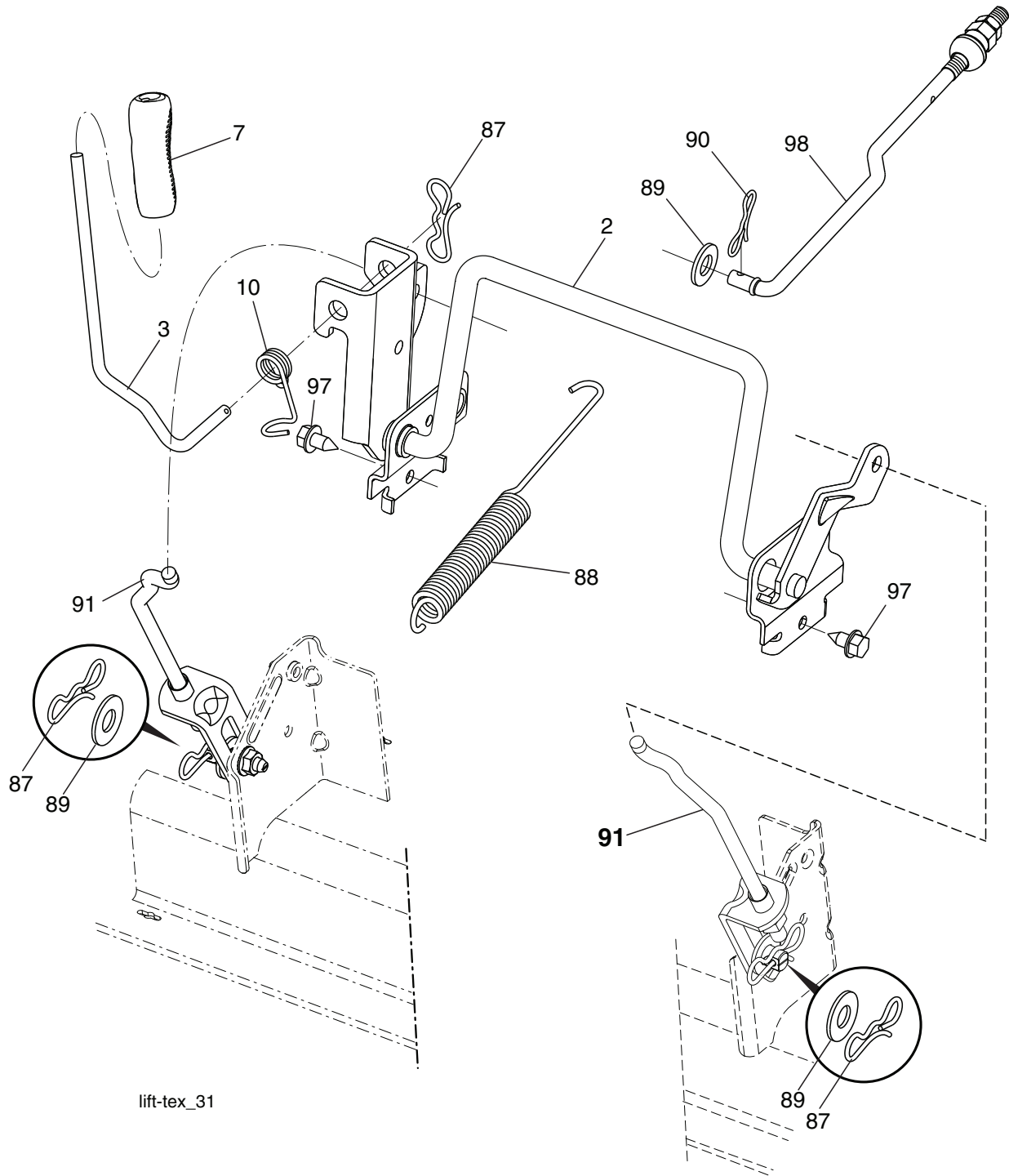

lift-tex_31

KEY NO.	PART NO.	DESCRIPTION
2	532 43 69-96	Deck Lift
3	532 19 52-31	Lever Asm., Lift RH
7	580 96 23-01	Grip, Lever
10	532 19 63-14	Spring Torsion
87	532 19 42-09	Pin Cotter 7/16 Bow Tie Lock
88	532 43 69-95	Spring Lift Assist
89	819 19 19-12	Washer 17/32 x 1-3/16 x 12 Ga.
90	532 19 42-08	Pin Cotter 5/16 Bow Tie Lock

KEY NO.	PART NO.	DESCRIPTION
91	532 19 51-81	Link Lift Susp Mower Rear
97	817 49 06-08	Screw 3/8-16 x 1/2
98	532 42 05-25	Link Lift Susp. Front Mower

NOTE: All component dimensions given in U.S. inches
 1 inch = 25.4 mm

**TRACTOR - MODEL NO. M125-97TC (96051011300), PROD. NO. 960 51 01-13
SEAT ASSEMBLY 42**

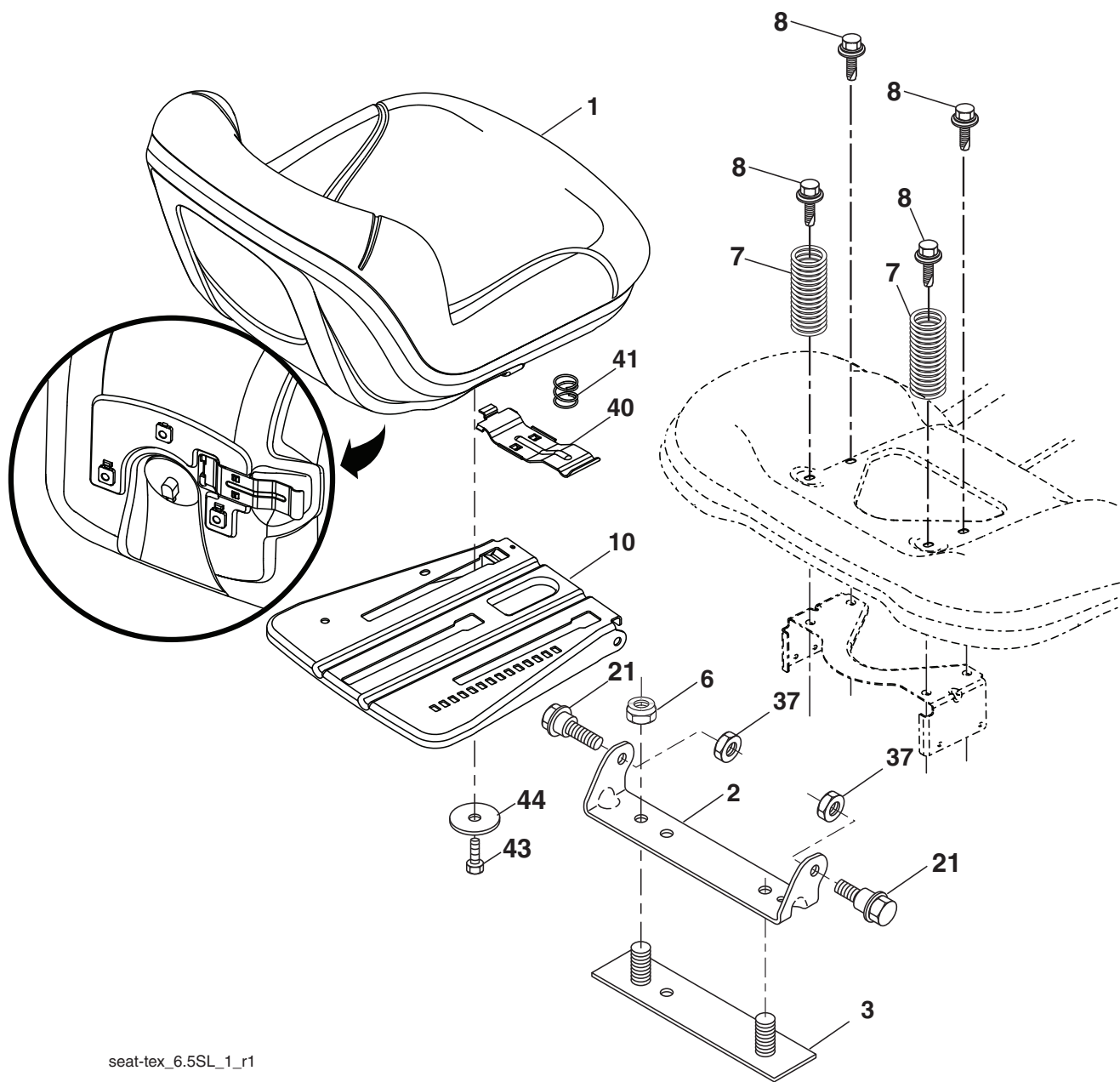

seat-tex_6.5SL_1_r1

KEY NO.	PART NO.	DESCRIPTION
1	581 46 20-01	Seat
2	532 18 01-66	Bracket Pnt Pivot Fender
3	532 14 06-75	Strap
6	873 80 06-00	Nut Lock Hex w/Ins 3/8-16
7	532 12 41-81	Spring Seat Cprsn 2 250 Blk Zi
8	532 17 18-77	Bolt 5/16-18 unc x 3/4
10	532 19 69-77	Pan Pnt Seat
21	532 17 18-52	Bolt Shoulder 5/16-18 unc-2A

KEY NO.	PART NO.	DESCRIPTION
37	873 80 05-00	Nut Hex Lock w/Ins 5/16-18
40	532 19 76-61	Handle Slide
41	532 19 82-00	Spring Latch
43	874 76 06-12	Bolt 3/8-16 unc x 3/4
44	819 13 38-12	Washer 13/32 x 2-3/8 x 12 Ga.

NOTE: All component dimensions given in U.S. inches
1 inch = 25.4 mm

TRACTOR - MODEL NO. M125-97TC (96051011300), PROD. NO. 960 51 01-13
BAGGER **46**

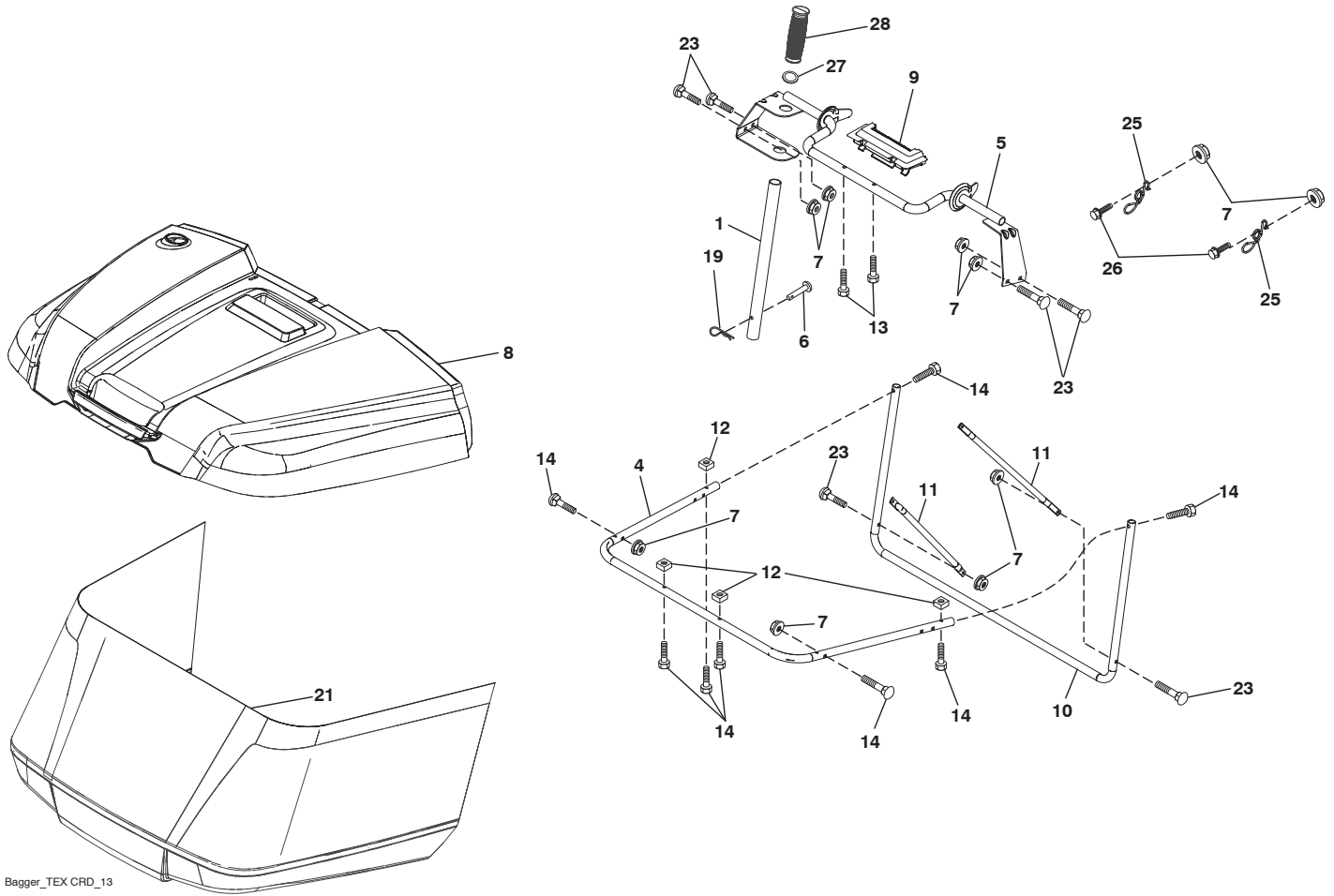

Bagger_TEX CRD_13

**TRACTOR - MODEL NO. M125-97TC (96051011300), PROD. NO. 960 51 01-13
BAGGER **46****

KEY NO.	PART NO.	DESCRIPTION
1	532 42 86-10	Tube Handle Bagger
4	532 43 96-12	Frame Asm Bagger Top
5	532 41 76-32	Frame Asm Top Bagger
6	532 12 68-75	Rivet Drilled
7	873 90 04-00	Nut Hex Flange 1/4-20 unc
8	532 42 59-54	Cover Bagger
9	532 41 76-29	Insert Handle Bagger
10	532 43 67-70	Frame Front
11	532 43 67-71	Tubing Brace Bagger
12	532 42 17-93	Nut Square 1/4
13	532 42 17-80	Screw 1/4 x 1.150
14	532 42 18-00	Bolt Shoulder 1/2 x 1.150
19	532 19 42-08	Cotter Pin 5/16 Bow Tie
21	581 33 70-01	Bag Asm
23	872 04 04-10	Bolt Carr. 1/4-20
25	532 42 16-14	Spring Latch Bagger
26	817 49 04-12	Screw Hex Wsh thdrol 1/4-20 x 3/4
27	532 42 12-62	Grommet Rubber
28	532 16 57-87	Grip Handle Black

NOTE: All component dimensions given in U.S. inches
1 inch = 25.4 mm

