

# **ILLUSTRATED PARTS LIST**

**MODEL NO. 96041035700**

**CUSTOMER CATALOG NO. M200-117T**

**PRODUCT NO. 960 41 03-57**

**TRACTOR - - MODEL NO. M200-117T (96041035700), PRODUCT NO. 960 41 03-57  
DECALS 27**

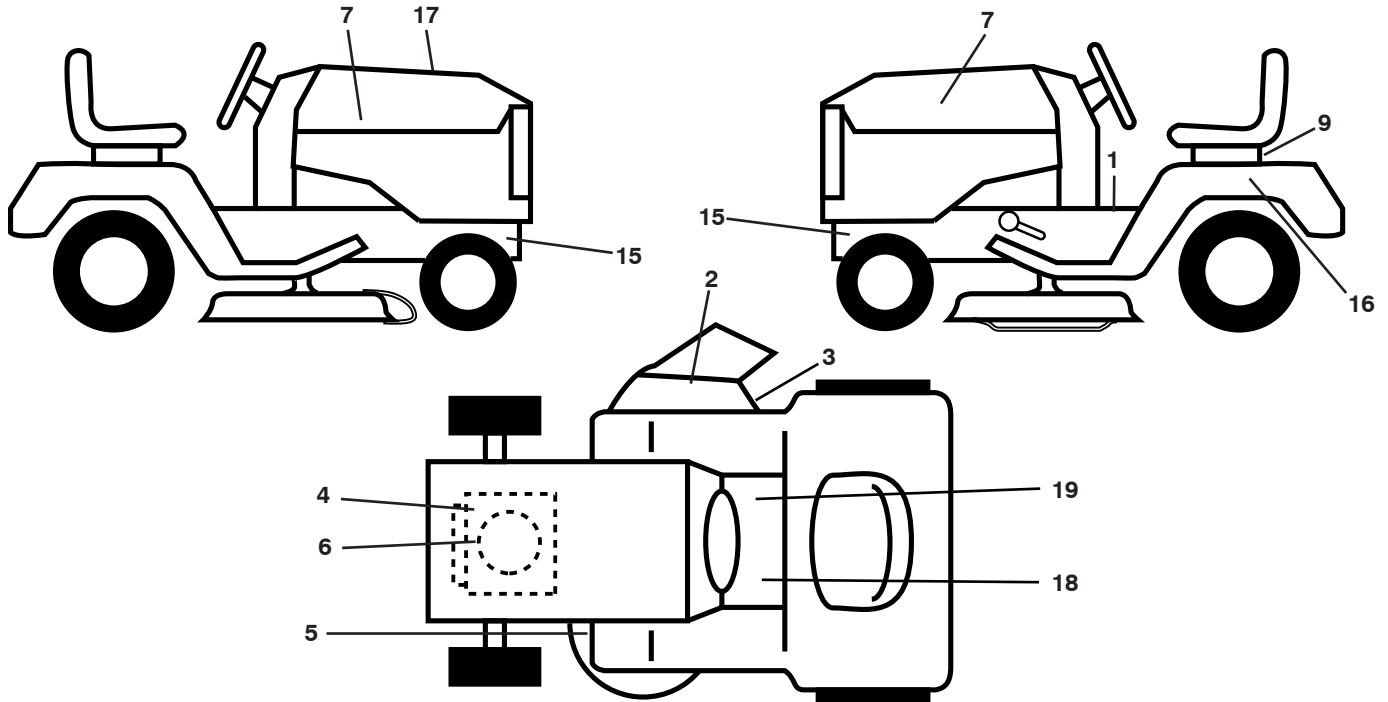

KEY NO.	PART NO.	DESCRIPTION
1	581 57 81-01	Decal, Read Manual
2	584 90 46-01	Decal, Deflect. Warning
3	581 57 92-01	Decal, Warning
4	581 57 97-01	Decal, Warning Engine
5	581 58 00-01	Decal, V-Belt Sch.
6	581 25 90-01	Decal, Eng. HP
7	581 09 12-01	Decal, Hood LH/RH
9	532 14 50-05	Decal, Battery Dnge/Poi
15	581 57 96-01	Decal, Hot Muffler
16	581 95 30-01	Decal, Fender
17	581 59 21-01	Decal, Replacement

KEY NO.	PART NO.	DESCRIPTION
18	581 72 40-01	Decal, Clutch/Brake
19	581 57 80-01	Decal, Saddle Brake Parking
--	581 72 48-01	Decal, Bypass
--	581 72 46-01	Decal, Drawbar
--	532 40 95-05	Pad, Footrest, LH
--	532 40 95-07	Pad, Footpedal
--	585 44-14-40	Manual, Operator's Euro
--	585 44 14-50	Manual, Operator's Scan
--	585 44 14-20	Manual, Operator's EBloc
--	585 44 14-30	Manual, Operator's Baltic

**WHEELS AND TIRES**

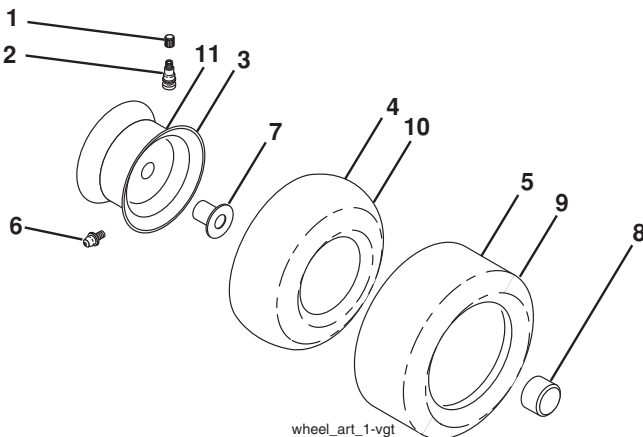

KEY NO.	PART NO.	DESCRIPTION
1	532 05 91-92	Cap, Valve, Tire
2	532 06 51-39	Stem, Valve
3	532 12 51-21	Rim Assembly, Front
4	532 05 99-04	Tube, Front (Service Item Only)
5	532 10 62-22	Tire, Front
6	532 12 49-57	Fitting, Grease (Front Wheel Only)
7	532 12 49-59	Bearing, Flange (Front Wheel Only)
8	532 19 32-68	Cap, Axle
9	532 13 84-68	Tire, Rear
10	532 12 49-26	Tube, Rear (Service Item Only)
11	532 12 51-22	Rim Assembly, Rear
--	532 14 43-34	Sealant, Tire (10 oz. Tube)

**NOTE:** All component dimensions given in U.S. inches  
1 inch = 25.4 mm

# TRACTOR - - MODEL NO. M200-117T (96041035700), PRODUCT NO. 960 41 03-57

## SCHEMATIC **38**

SCH10

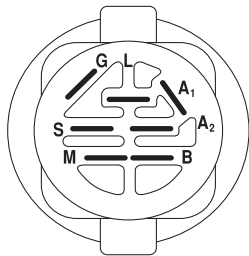
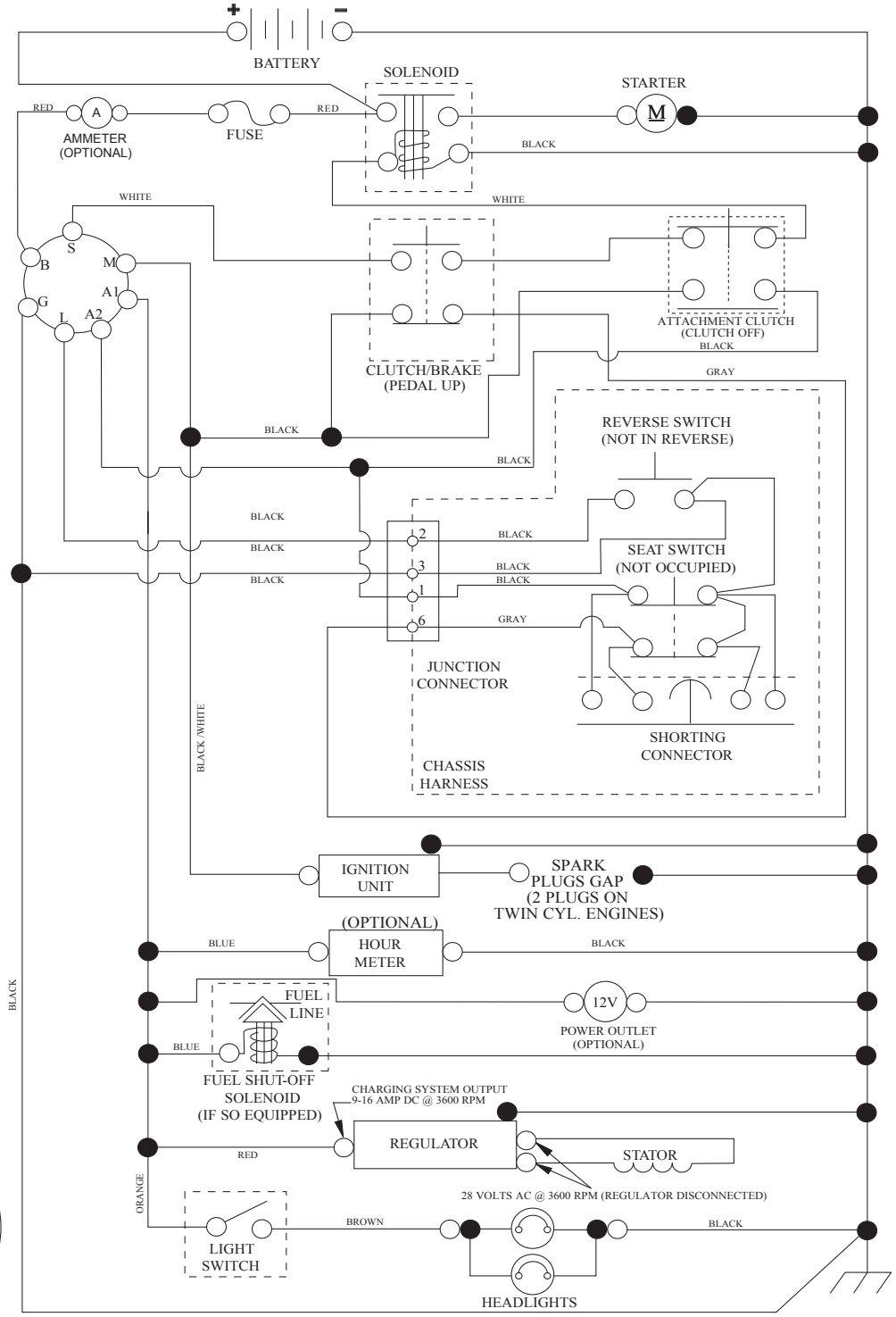

IGNITION SWITCH

POSITION	CIRCUIT	"MAKE"
OFF	M+G+A1	
RUN/OVERRIDE	B+A1	
RUN	B+A1	L+A2
START	B + S + A1	

03107

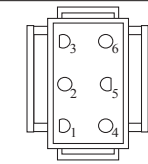

CHASSIS HARNESS CONNECTOR (MATING SIDE)

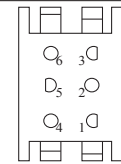

DASH HARNESS CONNECTOR (MATING SIDE)

WIRING INSULATED CLIPS  
NOTE: IF WIRING INSULATED CLIPS WERE REMOVED FOR SERVICING OF UNIT, THEY SHOULD BE RE-INSTALLED TO PROPERLY SECURE YOUR WIRING.

●  
NON-REMOVABLE CONNECTIONS

○  
REMOVABLE CONNECTIONS

**TRACTOR - - MODEL NO. M200-117T (96041035700), PRODUCT NO. 960 41 03-57**  
**ELECTRICAL 32**

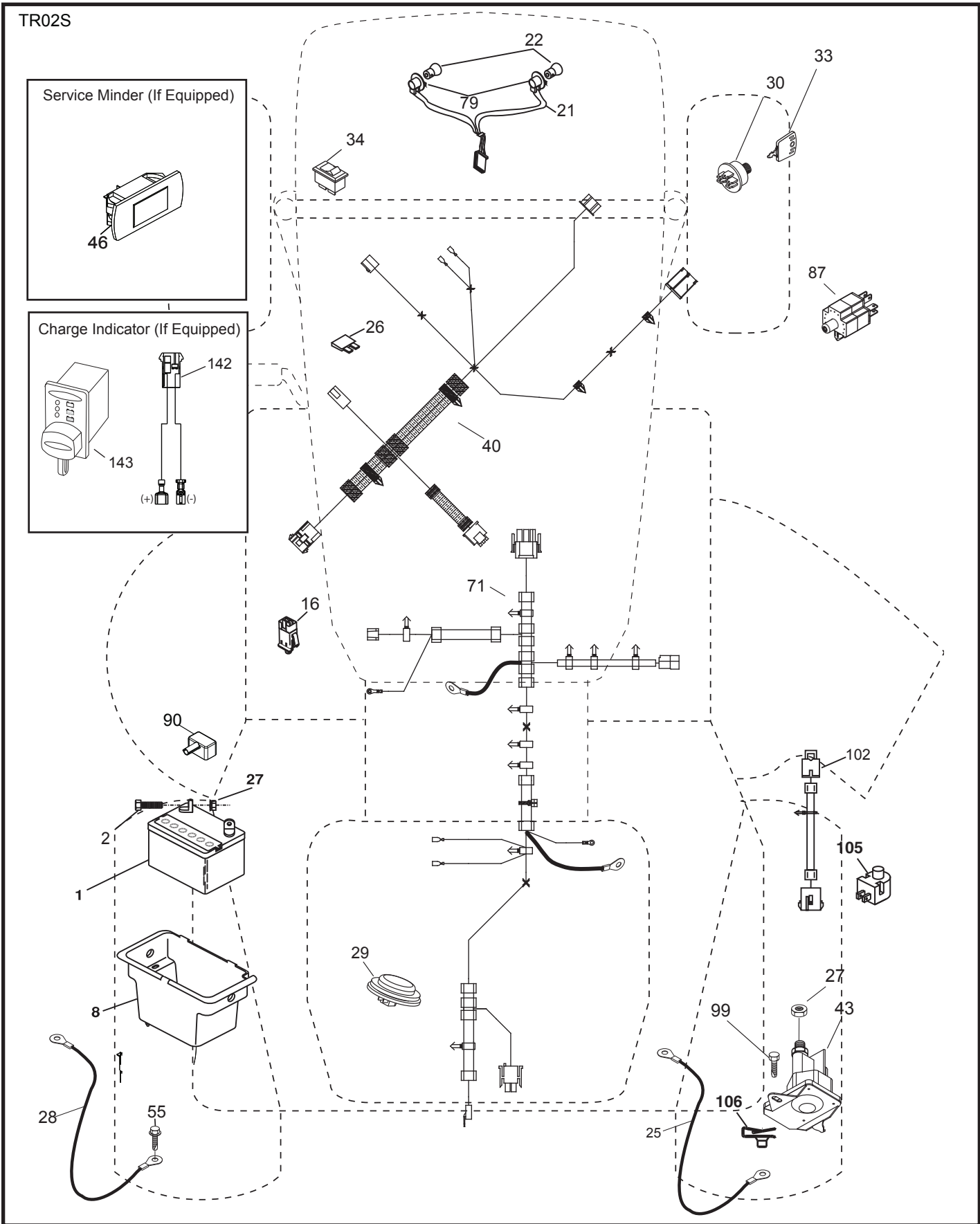

**TRACTOR - - MODEL NO. M200-117T (96041035700), PRODUCT NO. 960 41 03-57  
ELECTRICAL 32**

<b>KEY NO.</b>	<b>PART NO.</b>	<b>DESCRIPTION</b>
1	532 16 34-65	Battery
2	874 76 04-12	Bolt Hex Hd 1/4-20 unc x 3/4
8	532 19 32-28	Battery Box
16	532 17 61-38	Switch Interlock
21	532 40 02-52	Harness Socket Light W/4152J
22	532 00 41-52	Bulb, Light # 1156
25	581 49 80-01	Cable Starter
26	532 17 51-58	Fuse
27	873 51 04-00	Nut Keps Hex 1/4-20 unc
28	532 42 16-86	Cable Ground
29	532 40 15-45	Switch Seat
30	532 19 33-50	Switch Ign
33	532 41 19-35	Key/Chain
34	532 11 07-12	Switch Light/Reset
40	581 02 31-01	Harness Ign. Dash/Lift
43	532 19 25-07	Solenoid
55	817 06 05-12	Screw Thdrol 5/16-18 x 3/4
71	581 02 30-01	Ignition Chassis/Lift
79	532 17 52-42	Socket Asm. Bulb
87	532 19 78-02	Switch Interlock
90	532 43 53-95	Cover Terminal Battery
99	817 67 04-12	Screw Hexwsh
102	581 02 34-01	Harness Pigtail
105	532 40 75-68	Switch Reverse
106	532 17 48-14	Pal Nut 1/4 Lugs

**NOTE:** All component dimensions given in U.S. inches  
1 inch = 25.4 mm

TRACTOR -- MODEL NO. M200-117T (96041035700), PRODUCT NO. 960 41 03-57  
CHASSIS AND ENCLOSURES **39**

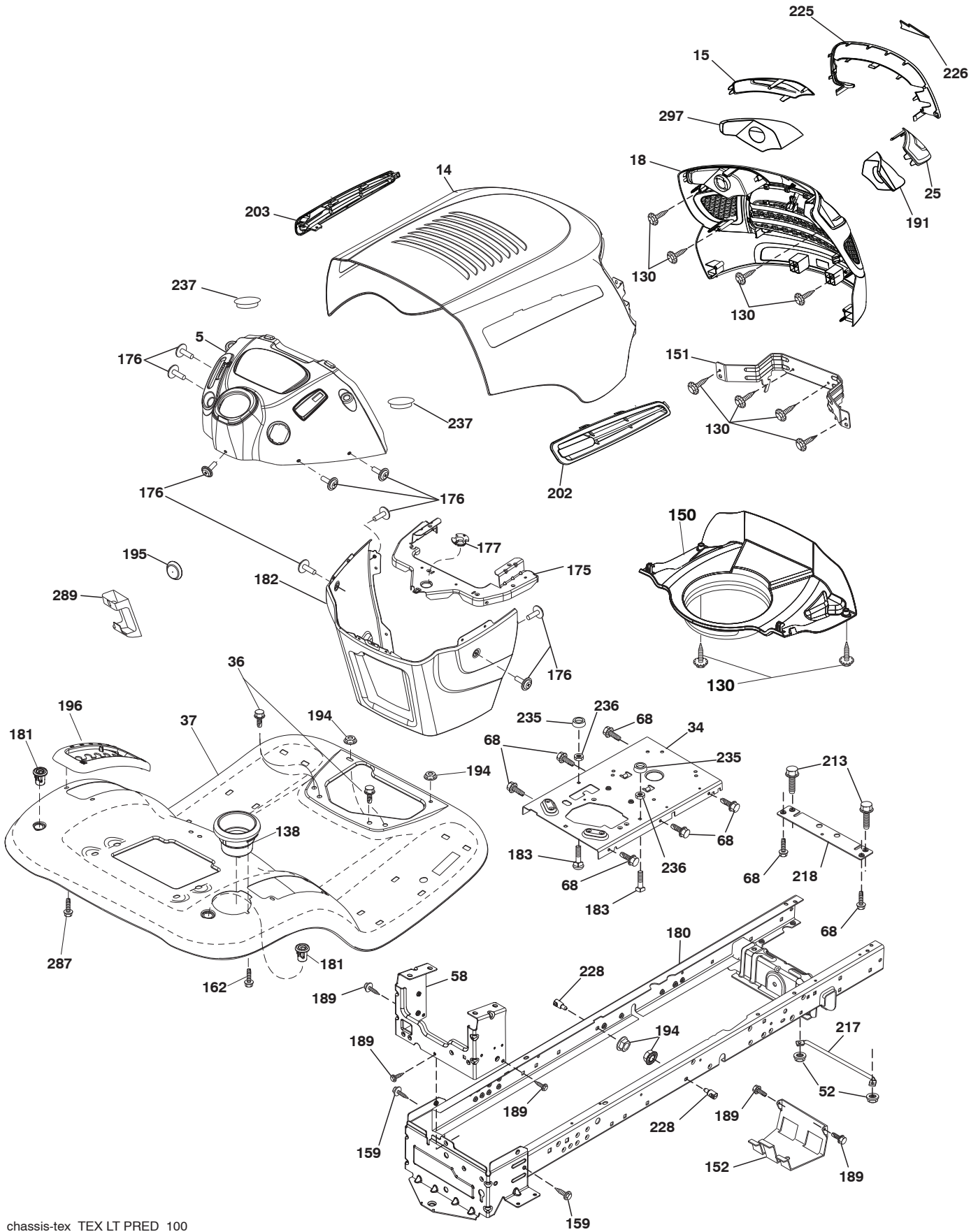

**TRACTOR - - MODEL NO. M200-117T (96041035700), PRODUCT NO. 960 41 03-57  
CHASSIS AND ENCLOSURES 39**

KEY NO.	PART NO.	DESCRIPTION
5	532 44 18-82	Dash
14	532 44 80-42	Hood
15	581 10 31-01	Lens LH
18	581 10 29-01	Grille
25	581 10 30-01	Lens RH
34	580 91 08-01	Plate Engine
36	817 06 05-12	Screw 5/16-18 x 3/4
37	532 42 07-96	Fender
52	873 68 05-00	Nut Crown Lock 5/16
58	532 41 22-80	Drawbar, Upper
68	817 49 05-08	Screw THDROL 5/16-18 x 1/2
130	532 41 63-58	Screw 10 x .750 BOS Thread
138	532 40 97-30	Cupholder
150	584 86 29-01	Air Duct
151	532 44 54-94	Bracket Pivot
152	532 19 95-35	Shield Browning
159	817 00 06-12	Screw Hexwsh Thdr 3/8-16 x 3/4 BL
162	532 14 24-32	Screw 1/4 x 1/2
175	532 19 63-04	Crossmember
176	532 40 07-76	Screw 10-24 x 5/8
177	532 19 52-28	Bushing Steering
180	532 41 50-63	Chassis
181	532 40 47-96	Bushing MNT Fender
182	532 40 68-59	Dash Lower
183	874 52 05-20	Bolt 5/16-18 x 1-1/4
189	817 00 05-12	Screw 5/16-18 x 3/4
191	532 22 35-01	Reflector RH
195	532 40 41-37	Plug Hole Dash Lower
194	873 90 05-00	Nut Lock Hex Flange 5/16-18
196	532 41 45-81	Console Deck Lift Asm.
202	581 85 91-01	Vent Side Hood RH
203	581 85 92-01	Vent Side Hood LH
213	874 76 05-12	Bolt 5/16-18 x 3/4
217	532 40 91-67	Rod Pivot Hood
218	532 19 63-95	X-Piece Hood Stop
225	581 10 32-01	Trim Ring
226	578 89 71-01	Emblem
228	532 19 51-61	Stud Fastener
235	532 40 61-29	Spacer Fender
236	873 93 05-00	Nut Lock 5/16-18 unc
237	532 40 37-04	Plug Mount Cargo
287	817 60 04-06	Screw Hex Washhead 1/4-20 x 3/8
289	532 40 35-71	Plug Cruise/Phone Common YTGT
297	581 22 36-01	Reflector LH
- -	532 44 11-26	Plug Dash Serviceminder
- -	532 40 09-44	Bumper

**NOTE:** All component dimensions given in U.S. inches  
1 inch = 25.4 mm

TRACTOR - - MODEL NO. M200-117T (96041035700), PRODUCT NO. 960 41 03-57  
DRIVE **40**

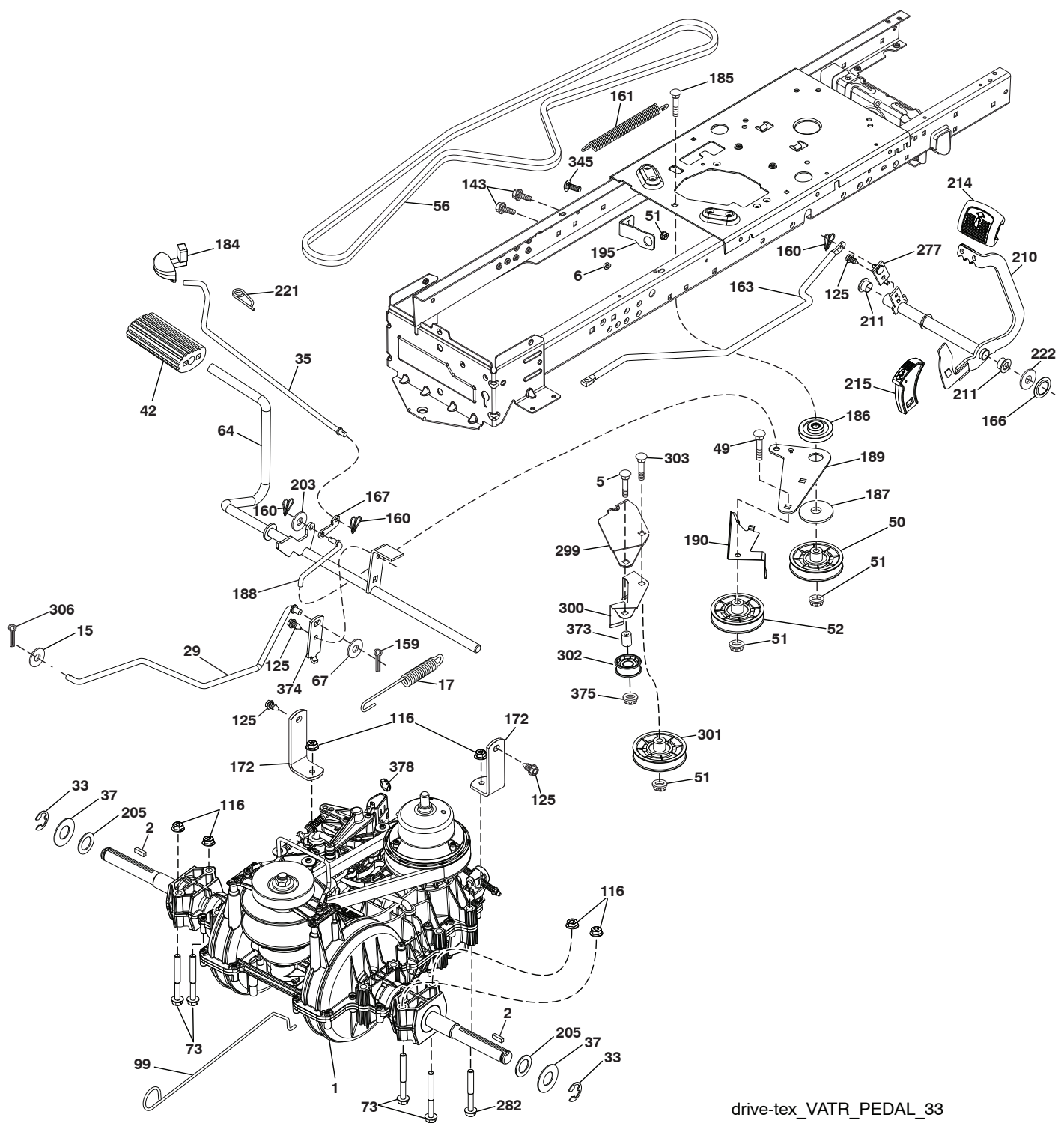

drive-tex\_VATR\_PEDAL\_33



**TRACTOR - - MODEL NO. M200-117T (96041035700), PRODUCT NO. 960 41 03-57  
DRIVE 40**

KEY NO.	PART NO.	DESCRIPTION	KEY NO.	PART NO.	DESCRIPTION
1	---	Transaxle, Variator SD Pedal (580486201) (Order parts from transaxle manufacturer.)	187	819 13 32-10	Washer 13/32 x 2 x 10 ga
2	532 12 35-83	Key Square	188	532 19 43-23	Link Clutch Ground Drive
5	874 76 06-36	Bolt 3/8-16 x 2-1/4	189	532 19 43-17	Bellcrank Ground Drive
6	532 12 40-28	Bushing Snap	190	532 19 43-18	Keeper. Bellcrank
15	819 13 13-16	Washer 13/32 x 13/16 x 16 Ga.	195	581 50 46-01	Bracket Brake
17	584 95 40-01	Spring, Brake	203	819 11 11-16	Washer 11/32 x 11/16 x 16 Ga.
29	584 82 31-01	Rod, Brake	205	532 12 17-48	Washer 25/32 x 1-5/8 16 Ga.
33	812 00 00-01	Ring E	210	532 44 82-70	Rocker Asm. Pedal
35	583 86 45-01	Rod, Brake, Park	214	532 42 12-63	Pedal Forward
37	532 18 89-67	Washer .793 x 1.637 x 060	215	532 44 82-54	Pad Pedal Reverse
42	532 12 48-72	Cover, Foot Pedal	211	532 12 01-83	Bearing Nylon
49	872 11 06-14	Bolt 3/8-16 unc	221	532 40 31-87	Retainer Spring
50	532 19 43-27	Idler Flat	222	879 21 20-10	Washer Flat
51	873 90 06-00	Nut Lock	277	532 44 85-00	Subasm. Link Rocker Pedal
52	532 19 43-26	Idler V-Groove	282	874 49 05-48	Screw Thdrol 5/16-18 x 3
56	581 60 38-01	V-Belt, Drive	299	532 41 56-83	Bracket Mount
64	532 44 83-53	Subasm. Shaft Pedal Brake	300	532 41 56-81	Keeper Idler
67	819 13 13-12	Washer 13/32 x 13/16 x 12 Ga.	301	532 41 56-80	Pulley Idler Groove
73	874 49 05-44	Bolt Hex 5/16-18 x 3.75	302	581 42 05-01	Puller Idler Flat
99	532 43 59-35	Rod Bypass	303	872 11 06-18	Bolt
116	873 90 05-00	Nut Lock Hex Flange 5/16-18	306	876 02 04-16	Cotter Pin
125	817 00 05-12	Screw 5/16-18 x 3/4	345	872 11 06-06	Bolt 3/8-16 unc
143	817 49 05-08	Screw Thdrol 5/16-18 x 1/2 TYTT	373	581 46 18-01	Spacer Idler
159	876 02 04-12	Pin Cotter 1/8 x 3/4	374	581 47 52-01	Arm Control Brake
160	532 16 94-84	Retainer Clip	375	873 68 06-00	Nut Crownlock 3/8-16 unc.
161	532 10 57-09	Spring, Return, Clutch	378	584 28 77-01	Nut Push 8 mm
163	583 97 13-01	Rod Control			
166	532 42 91-64	Nut Push .625			
167	532 40 52-57	Latch Brake Parking			
172	583 97 42-01	Strap Torque			
184	532 44 14-55	Handle Park Brk.			
185	872 11 06-22	Bolt 3/8-16 unc x 2-3/4			
186	532 19 43-21	Spacer Retainer			

**NOTE:** All component dimensions given in U.S. inches  
1 inch = 25.4 mm

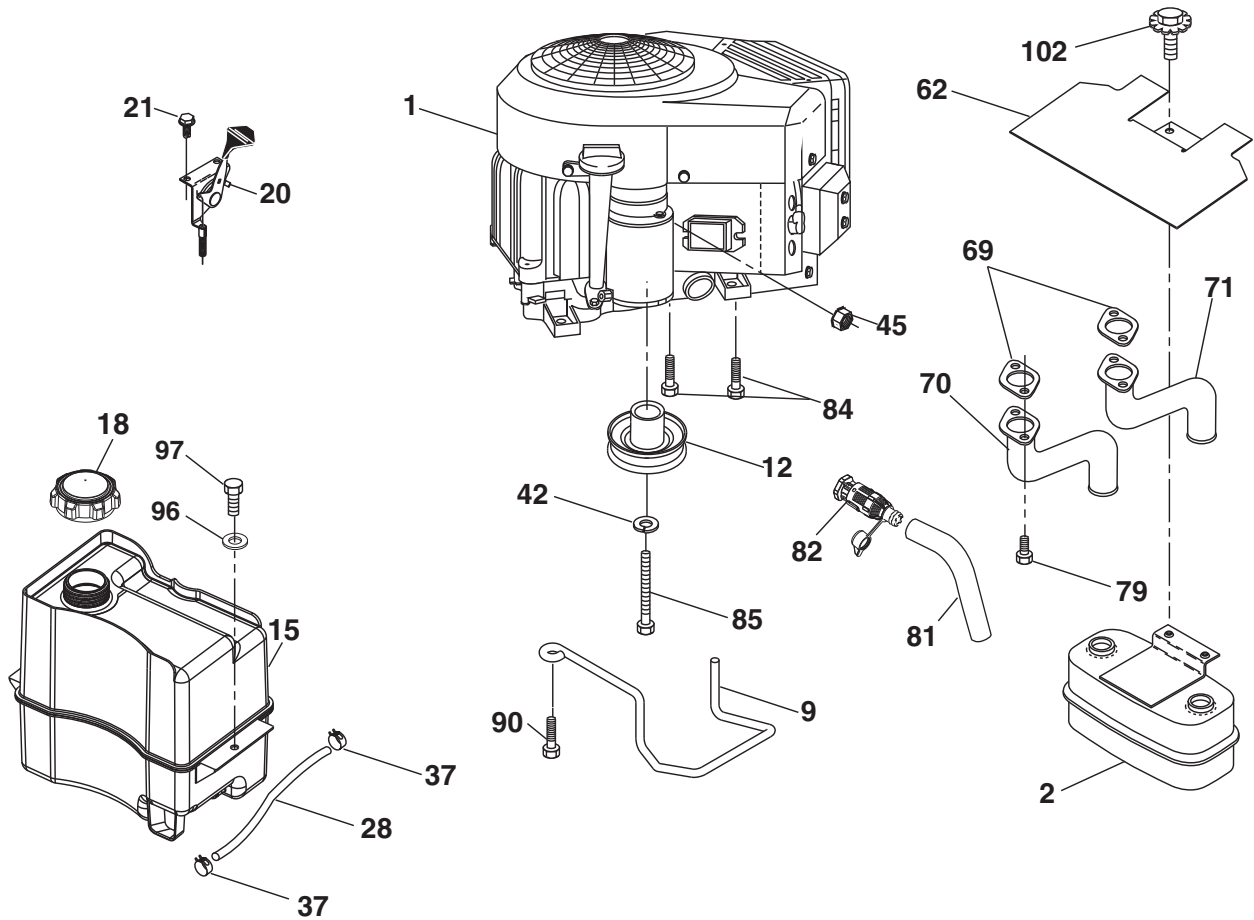

**SPARK ARRESTER KIT**

engine-tex\_bs-2cyl\_96\_r1

**TRACTOR - - MODEL NO. M200-117T (96041035700), PRODUCT NO. 960 41 03-57  
ENGINE 24**

KEY NO.	PART NO.	DESCRIPTION
1	- - - - -	Engine Briggs Model No. 40R777-0003-B1 (585767001) (Order parts from engine manufacturer.)
2	532 14 97-23	Muffler
9	584 90 80-01	Keeper Belt Engine
12	532 40 54-72	Pulley Engine
15	532 40 75-51	Tank Fuel
18	532 43 02-20	Cap Asm
20	532 42 35-02	Control Throttle
21	532 41 63-58	Screw #10 x 0.750 BOS Thread
28	532 13 70-40	Fuel Line
29	532 13 71-80	Spark Arrester Kit
37	532 12 34-87	Clamp Hose
42	810 04 07-00	Washer Lock 7/16
45	873 51 04-00	Nut Keps Hex 1/4-20 unc
62	532 43 40-17	Shield Heat
69	532 16 53-91	Gasket
70	581 88 11-01	Exhaust Tube RH
71	581 88 10-01	Exhaust Tube LH
79	532 18 39-06	Screw 5/16-18 x 1
81	532 14 84-56	Tube Drain Oil Easy
82	532 42 82-87	Valve Oil Drain
84	817 06 06-20	Screw 3/8-16 x 1-1/4
85	532 17 39-37	Bolt 7/16-20 x 4
90	817 00 06-16	Screw 3/8-16 x 1
96	819 09 14-16	Washer 9/32 x 7/8 x 16 Ga.
97	817 67 04-12	Screw 1/4 - 20 x 3/4
102	817 00 05-12	Screw 5/16-18 x 3/4

**NOTE:** All component dimensions given in U.S. inches  
1 inch = 25.4 mm

**Engine Power Rating Information**

The gross power rating for individual gas engine models is labeled in accordance with SAE (Society of Automotive Engineers) code J1940 (Small Engine Power & Torque Rating Procedure), and rating performance has been obtained and corrected in accordance with SAE J1995 (Revision 2002-05). Torque values are derived at 3060 RPM; horsepower values are derived at 3600 RPM. Actual gross engine power will be lower and is affected by, among other things, ambient operating conditions and engine-to-engine variability. Given both the wide array of products on which engines are placed and the variety of environmental issues applicable to operating the equipment, the gas engine will not develop the rated gross power when used in a given piece of power equipment (actual "on-site" or net power). This difference is due to a variety of factors including, but not limited to, accessories (air cleaner, exhaust, charging, cooling, carburetor, fuel pump, etc.), application limitations, ambient operating conditions (temperature, humidity, altitude), and engine-to-engine variability. Due to manufacturing and capacity limitations, Briggs & Stratton may substitute an engine of higher rated power for this Series engine.



**TRACTOR - - MODEL NO. M200-117T (96041035700), PRODUCT NO. 960 41 03-57  
STEERING ASSEMBLY 41**

<b>KEY NO.</b>	<b>PART NO.</b>	<b>DESCRIPTION</b>
1	532 44 28-04	Wheel, Steering
2	532 41 81-68	Axle Asm., Front
4	532 40 30-87	Spindle Asm., LH
5	532 40 30-88	Spindle Asm., RH
6	532 12 49-31	Bearing, Race Thrust Harden
7	532 12 17-48	Washer 25/32 x 1-5/8 x 16 Ga.
8	812 00 00-29	Ring, Clip #T5304-75
9	532 12 12-32	Cap, Spindle
13	532 12 17-49	Washer 25/32 x 1-1/4 x 16 Ga.
14	810 04 06-00	Washer, Lock Hvy Hlcl Spr 3/8
15	873 54 06-00	Nut, Crown Lock 3/8-24 unf
16	587 01 60-02	Steering Shaft
19	532 19 47-29	Plate Steering
20	532 42 47-40	Boot Steering
21	586 84 02-01	Adapter Wheel Steering
22	585 02 98-02	Bearing
26	532 44 77-59	Insert, Wheel Steering
27	819 21 16-16	Washer
28	817 00 06-12	Screw 3/8-16 x 3/4
35	532 19 47-32	Gear, Sector Plate
45	587 01 64-01	Washer 3/8 ID 2-3/8 OD 12 Ga. PLTD
50	873 90 06-00	Nut Lock Flg 3/8-16 unc
53	532 18 89-67	Washer Hardened .793 x 1.637 x .060
57	532 40 74-65	Bracket Upstop
58	532 19 47-47	Bolt Shoulder Sector Pivot CFM
59	532 19 47-48	Washer Thrust Sector Steering
60	873 97 10-00	Nut Flange Lock 5/8-11
61	532 19 47-40	Draglink LH
62	532 19 47-41	Draglink, RH
63	817 00 05-12	Screw 5/16-18 x 3/4
64	532 19 98-49	Retainer Clip Spring Steering
66	871 02 07-48	Bolt Hex Fghd 7/16-14 x 3 Serr
67	532 19 47-37	Bushing PM Front Axle
68	873 90 07-00	Nut Lock Flange 7/16-14 Gr. 5
69	532 19 91-62	Washer 1.5 x .505 x .118
70	532 19 61-97	Bracket Deck Susp. Front
74	532 12 49-37	Bearing
75	580 68 37-01	Pinion
76	580 68 36-01	Screw Head Sock
122	532 44 49-62	Cap Gear Sector

**NOTE:** All component dimensions given in U.S. inches  
1 inch = 25.4 mm

TRACTOR -- MODEL NO. M200-117T (96041035700), PRODUCT NO. 960 41 03-57  
MOWER DECK 44

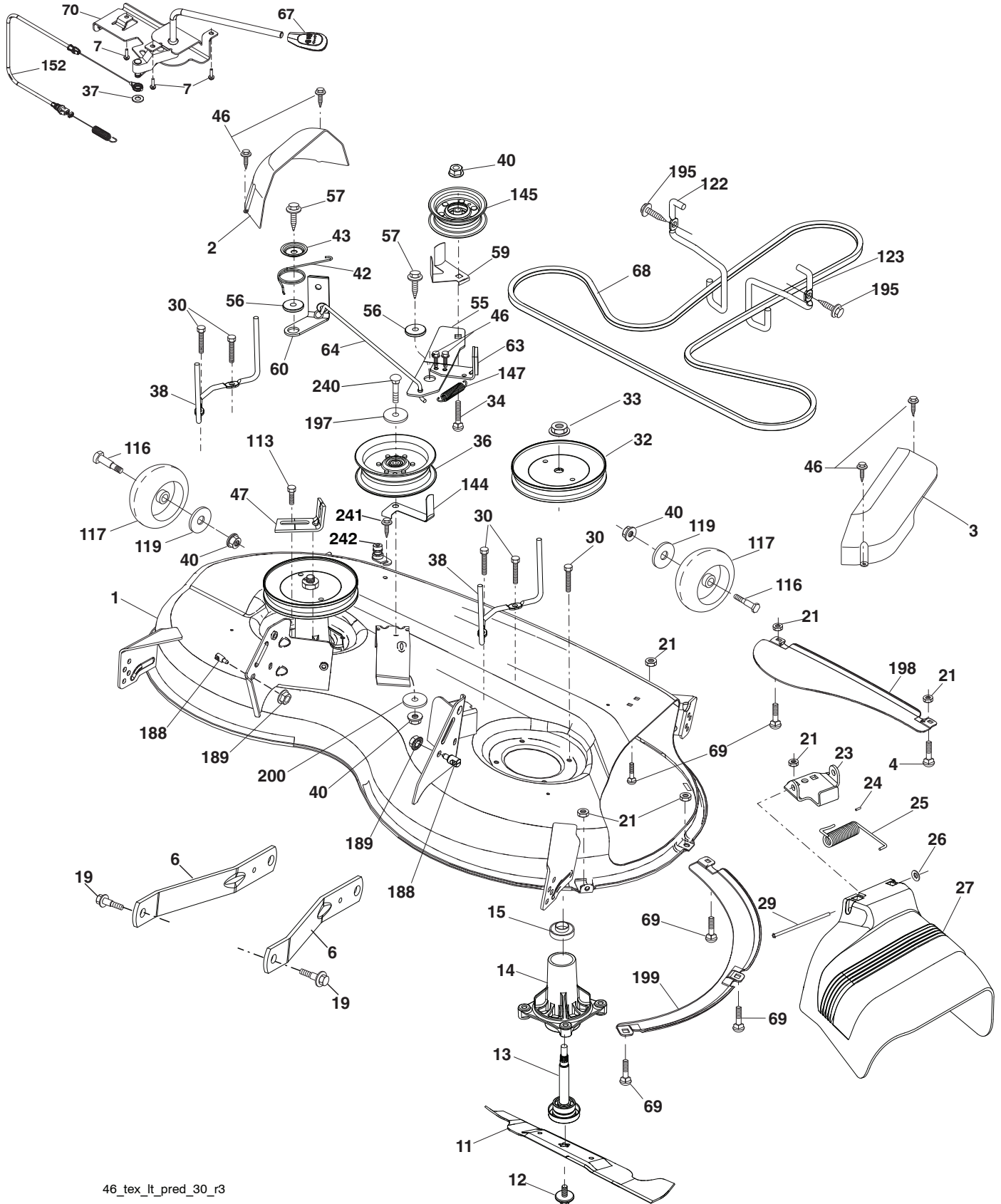

46\_tex\_lt\_pred\_30\_r3

**TRACTOR - - MODEL NO. M200-117T (96041035700), PRODUCT NO. 960 41 03-57  
MOWER DECK 44**

KEY NO.	PART NO.	DESCRIPTION	KEY NO.	PART NO.	DESCRIPTION
1	532 44 16-16	Mower Housing	67	532 40 30-12	Handle Clutch Cable
2	532 40 55-07	Cover Mandrel LH	68	532 40 51-43	Belt, Drive
3	532 40 55-06	Cover Mandrel RH	69	872 14 05-05	Bolt
4	874 76 05-12	Bolt Hex HD 5/16-18	70	532 19 99-72	Clutch Asm. Manual
6	532 19 51-86	Arm Suspension	113	817 00 05-10	Bolt 5/16-18
7	532 41 63-58	Screw #10 x 0.750	116	532 19 34-06	Bolt, Shoulder
11	532 40 53-80	Blade	117	532 17 48-73	Wheel, Gauge
12	584 30 93-01	Screw	119	819 13 20-12	Washer 13/32 x 1-1/4 x 12 Ga.
13	587 25 65-01	Shaft Assembly, Mandrel	122	532 19 72-58	Keeper Belt Engine LH
14	532 18 72-81	Housing, Mandrel	123	532 19 72-59	Keeper Belt Engine RH
15	585 32 39-01	Bearing, Mandrel	144	532 19 92-04	Keeper Belt Mower
19	532 19 65-39	Bolt, Shoulder	145	532 19 73-79	Pulley Idler
21	873 68 05-00	Nut, Crownlock 5/16-18 unc	147	532 40 18-72	Spring Mower Deck
23	532 19 25-57	Bracket, Deflector	152	584 24 35-01	Cable Clutch Manual
24	532 10 53-04	Cap, Sleeve	188	532 19 51-61	Stud Fastener
25	532 19 70-26	Spring, Torsion, Deflector	189	873 90 05-00	Nut Lock Hex Flange
26	532 11 04-52	Nut, Push	195	817 00 06-12	Screw 3/8-16 x 3/4
27	532 40 53-57	Shield, Deflector	197	819 13 13-12	Washer 13/32 x 13/16 x 12 Ga.
29	532 13 14-91	Rod, Hinge	198	532 40 31-49	Baffle Center Front
30	532 17 39-84	Screw Thdrol Rolling Wsh Hd	199	532 40 31-50	Baffle Front RH
32	532 19 74-73	Pulley, Mandrel	200	532 41 35-24	Washer 13/32 x 1 x 1/2 x 11 Ga.
33	532 40 02-34	Nut, Toplock, Flanged	240	874 52 06-36	Bolt Fin Hex 3/8-16 x 2-1/4 Gr. 5
34	872 11 06-12	Bolt Carr Sh. 3/8-16 x 1-1/2 Gr. 5	241	532 15 29-27	Screw #10-32.5 3/8 Flange
36	532 19 31-97	Pulley, Idler, Primary	242	532 41 55-98	Port Washout
37	819 13 13-16	Washer 13/32 x 13/16 x 16 Ga.	--	587 25 33-01	Mandrel Assembly (Includes housing (key# 14), shaft assembly (key# 13), bearing (key# 15) and nut (key# 33) only-pulley/washer and blade bolt/washer not included.)
38	532 43 25-20	Keeper Belt Mower	--	532 41 80-63	Replacement Mower, Complete
40	873 90 06-00	Nut, Lock Flg. 3/8-16 unc			
42	532 19 84-10	Spring Torsion Brake			
43	532 19 72-56	Spring Torsion Retainer			
46	532 13 77-29	Screw 1/4-20 x 5/8			
47	532 19 72-50	Clutch Cable			
55	532 19 72-49	Arm, Idler			
56	532 19 90-92	Spacer, Retainer			
57	817 00 06-16	Screw 3/8-16 x 1			
59	532 14 10-43	Guard, Tuv Idler			
60	532 19 94-71	Arm Brake Mower			
63	532 19 94-77	Arm Brake Mower			
64	532 40 51-38	Linkage Asm. Brake			

**NOTE:** All component dimensions given in U.S. inches  
1 inch = 25.4 mm



**TRACTOR -- MODEL NO. M200-117T (96041035700), PRODUCT NO. 960 41 03-57**  
**MOWER LIFT 45**

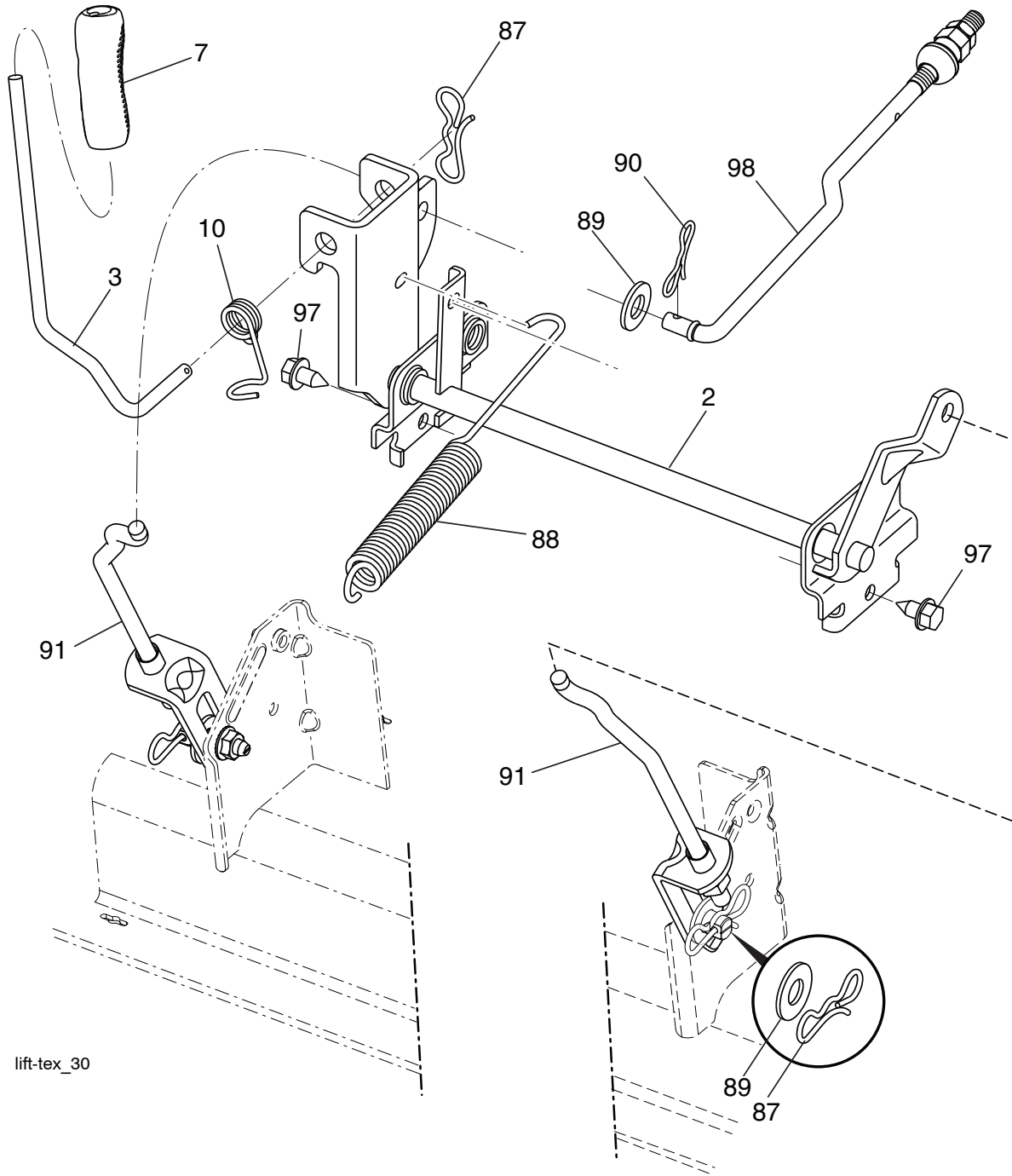

lift-tex\_30

KEY NO.	PART NO.	DESCRIPTION
2	532 42 20-27	Shaft Asm., Lift
3	532 19 52-31	Lever Asm., Lift RH
7	580 96 23-01	Grip, Lever
10	532 19 63-14	Spring Torsion
87	532 19 42-09	Pin Cotter 7/16 Bow Tie Lock
88	532 41 07-10	Spring Lift Assist
89	819 19 19-12	Washer 17/32 x 1-3/16 x 12 Ga.
90	532 19 42-08	Pin Cotter 5/16 Bow Tie Lock

KEY NO.	PART NO.	DESCRIPTION
91	532 19 79-84	Lift Link Asm. Rear
97	817 00 06-12	Screw 3/8-16 x .75
98	532 42 05-25	Link Lift Susp. Front Mower

**NOTE:** All component dimensions given in U.S. inches  
 1 inch = 25.4 mm



**TRACTOR - - MODEL NO. M200-117T (96041035700), PRODUCT NO. 960 41 03-57  
SEAT ASSEMBLY 42**

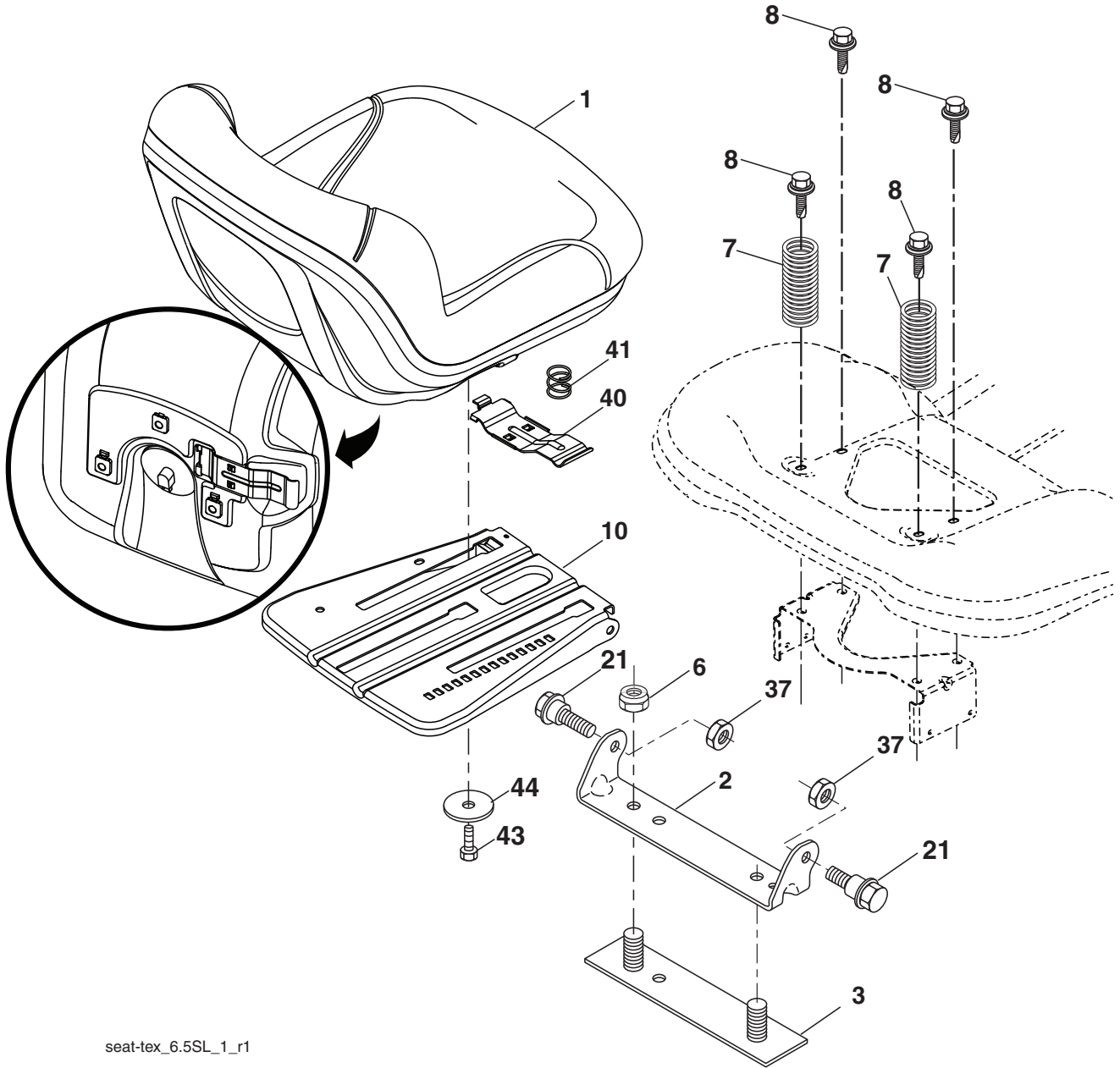

seat-tex\_6.5SL\_1\_r1

KEY NO.	PART NO.	DESCRIPTION
1	581 46 22-01	Seat
2	532 18 01-66	Bracket Pivot Fender
3	532 14 06-75	Strap, Asm Fender
6	873 80 06-00	Nut, Lock w/Ins. 3/8-16 unc
7	532 12 41-81	Spring, Seat Cprsn
8	532 17 18-77	Bolt 5/16-18 unc x 3/4 w/Sems
10	532 19 69-77	Pan, Seat
21	532 17 18-52	Bolt, Shoulder 5/16-18

KEY NO.	PART NO.	DESCRIPTION
37	873 80 05-00	Nut, Lock 5/16-18 unc
40	532 19 76-61	Handle Slide Seat
41	532 19 82-00	Spring Latch Seat
43	874 76 06-12	Bolt 3/8-16 x 3/4
44	819 13 38-12	Washer 13/32 x 2-3/8 x 12 Ga.

**NOTE:** All component dimensions given in U.S. inches  
1 inch = 25.4 mm

