

ILLUSTRATED PARTS LIST

MFG. ID NO. 96051006601

CUSTOMER CATALOG NO. M185-107TC

PRODUCT NO. 960 51 00-66

**TRACTOR - MODEL NO. M185-107TC (96051006601), PROD. NO. 960 51 00-66
DECALS 27**

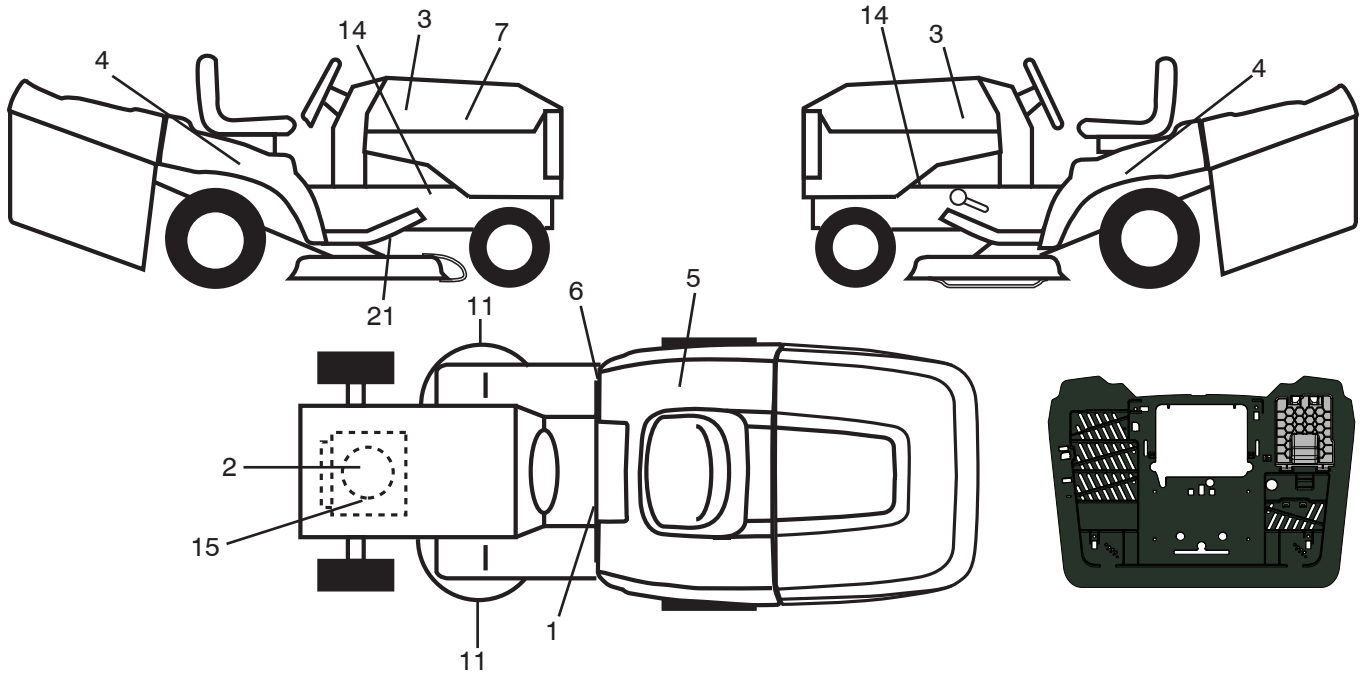

| KEY NO. | PART NO. | DESCRIPTION |
|---------|--------------|--------------------------------|
| 1 | 581 57 83-01 | Decal, Warning |
| 2 | 581 57 97-01 | Decal, Warning Eng. Sym. |
| 3 | 581 09 12-01 | Decal, Hood RH/LH |
| 4 | 581 92 55-01 | Decal, SD Fender |
| 5 | 581 72 41-01 | Decal, Certification |
| 6 | 581 57 86-01 | Decal, Pedals |
| 7 | 584 22 07-01 | Decal, Replacement |
| 11 | 581 57 91-01 | Decal, Mower Cut Finger Symbol |
| 14 | 581 57 96-01 | Decal, Chassis Hot Muffler |

| KEY NO. | PART NO. | DESCRIPTION |
|---------|--------------|----------------------------|
| 15 | 532 43 74-20 | Decal, Engine HP |
| 21 | 532 44 11-89 | Decal, Belt Sch CRD |
| -- | 532 42 59-86 | Pad Footrest RH |
| -- | 532 42 59-76 | Pad Footrest LH |
| -- | 584 26 30-40 | Manual Operator's (Euro) |
| -- | 584 26 29-50 | Manual Operator's (Scan) |
| -- | 584 26 27-20 | Manual Operator's (E-Bloc) |
| -- | 584 26 28-30 | Manual Operator's (Baltic) |

WHEELS & TIRES

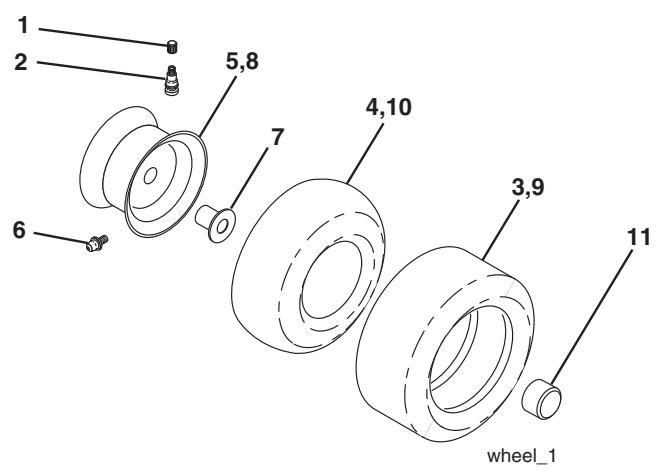

| KEY NO. | PART NO. | DESCRIPTION |
|---------|--------------|---------------------------------|
| 1 | 532 05 91-92 | Cap Valve Tire |
| 2 | 532 06 51-39 | Stem Valve |
| 3 | 532 10 62-22 | Tire F Ts 15 x 6 0 - 6 Service |
| 4 | 532 05 99-04 | Tube Inner Front #35060 |
| 5 | 532 12 51-21 | Rim Asm 6" Front Silver Service |
| 6 | 532 12 49-57 | Fitting Grease |
| 7 | 532 12 49-59 | Bearing Flange |
| 8 | 532 12 51-22 | Rim Asm 8" Rear Silver Service |
| 9 | 532 42 05-31 | Tire R.Ts-LT 18 x 9.5-8 C Ser. |
| 10 | 532 12 49-26 | Tube Rear 9 5 x 8 Service |
| 11 | 532 19 32-68 | Cap Axle Blk 1 50 x 1 00 |
| -- | 532 14 43-34 | Sealant, Tire (10 oz. Tube) |

NOTE: All component dimensions given in U.S. inches
1 inch = 25.4 mm

TRACTOR - MODEL NO. M185-107TC (96051006601), PROD. NO. 960 51 00-66

SCHEMATIC **38**

SCH17

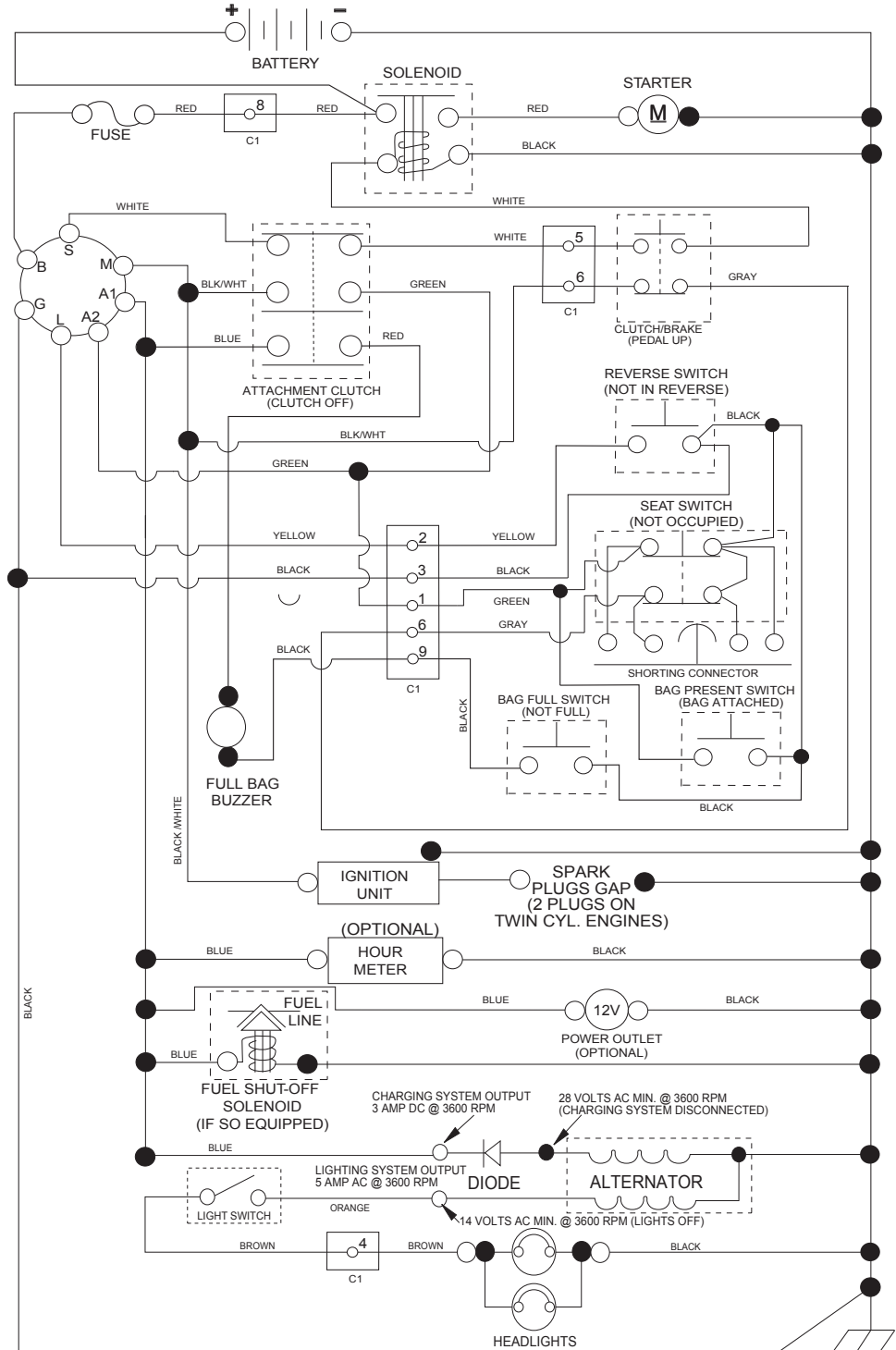

NOTE
YOUR TRACTOR IS EQUIPPED WITH A SPECIAL ALTERNATOR SYSTEM. THE LIGHTS ARE NOT CONNECTED TO THE BATTERY, BUT HAVE THEIR OWN ELECTRICAL SOURCE. BECAUSE OF THIS, THE BRIGHTNESS OF THE LIGHTS WILL CHANGE WITH ENGINE SPEED. AT IDLE THE LIGHTS WILL DIM. AS THE ENGINE SPEED IS INCREASED, THE LIGHTS WILL BECOME THEIR BRIGHTEST.

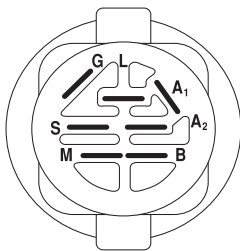

IGNITION SWITCH

| POSITION | CIRCUIT | "MAKE" |
|--------------|------------|--------|
| OFF | M+G+A1 | |
| RUN/OVERRIDE | B+A1 | |
| RUN | B+A1 | L+A2 |
| START | B + S + A1 | |

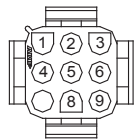

CHASSIS HARNESS CONNECTOR (C1) (MATING SIDE)

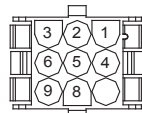

DASH HARNESS CONNECTOR (C1) (MATING SIDE)

WIRING INSULATED CLIPS
NOTE: IF WIRING INSULATED CLIPS WERE REMOVED FOR SERVICING OF UNIT, THEY SHOULD BE RE-INSTALLED TO PROPERLY SECURE YOUR WIRING.

NON-REMOVABLE CONNECTIONS

REMOVABLE CONNECTIONS

TRACTOR - MODEL NO. M185-107TC (96051006601), PROD. NO. 960 51 00-66
ELECTRICAL 32

TC03S

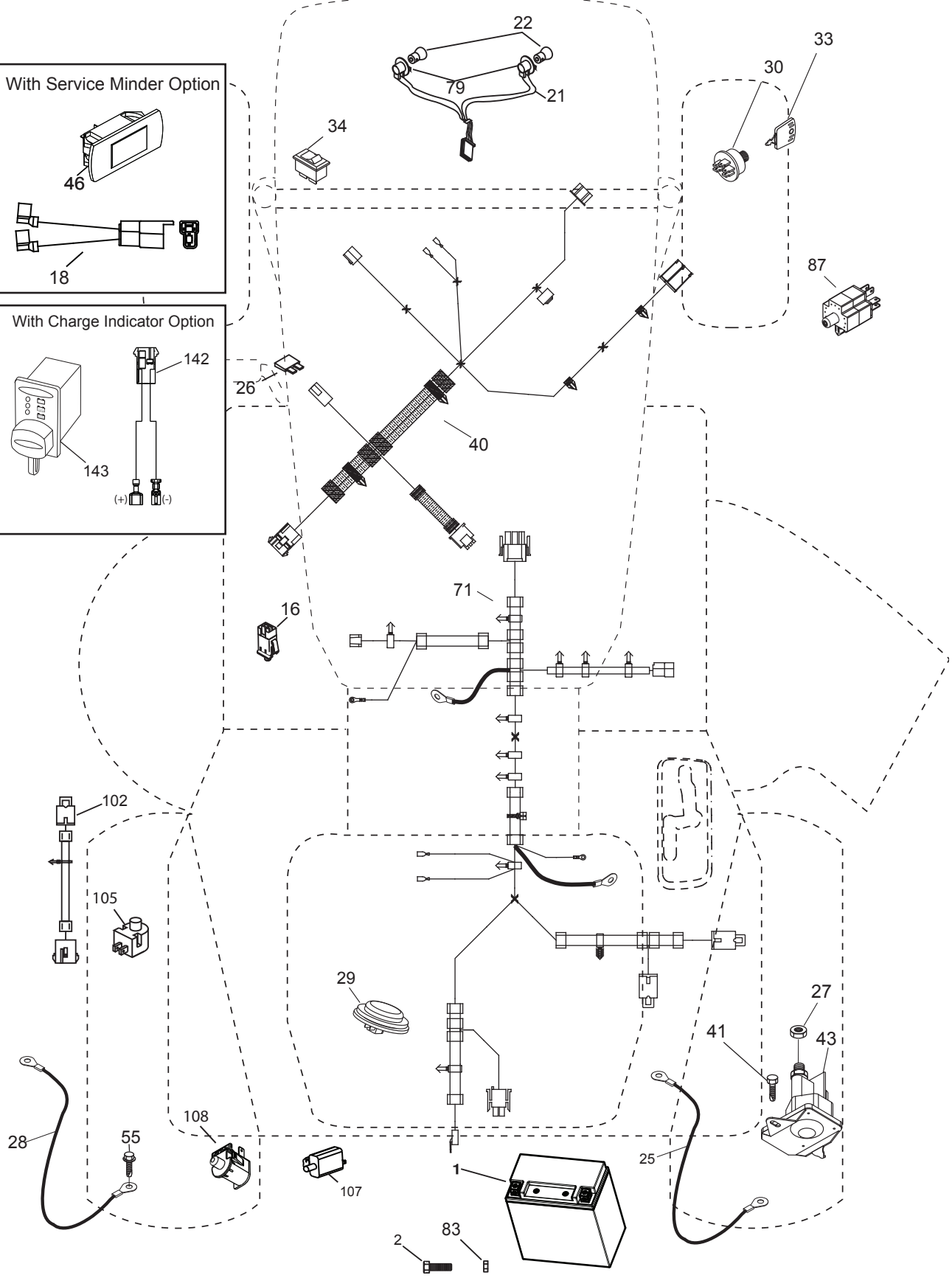
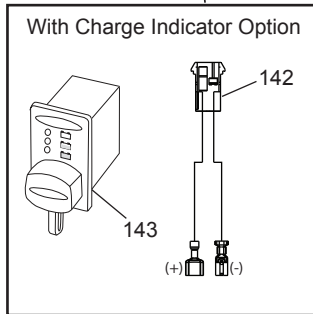
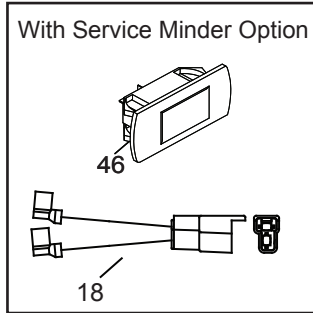

**TRACTOR - MODEL NO. M185-107TC (96051006601), PROD. NO. 960 51 00-66
ELECTRICAL 32**

| KEY NO. | PART NO. | DESCRIPTION |
|----------------|-----------------|--------------------------------|
| 1 | 532 43 71-57 | Battery |
| 2 | 532 43 67-74 | Screw Hex Hd Cap M6 x 1.12mm |
| 16 | 532 17 61-38 | Switch Interlock |
| 21 | 532 40 02-52 | Harness Asm Light w/4152J |
| 22 | 532 00 41-52 | Bulb Light #1156 |
| 25 | 532 44 13-82 | Cable Battery 8 AWG 20"-Red |
| 26 | 532 17 51-58 | Fuse |
| 27 | 873 51 04-00 | Nut Keps Hex 1/4-20 unc |
| 28 | 532 44 13-83 | Cable Ground 8 AWG 20"-Black |
| 29 | 532 40 15-45 | Switch Seat |
| 30 | 532 19 33-50 | Switch Ignition |
| 33 | 532 41 19-35 | Key/Chain |
| 34 | 532 11 07-12 | Switch Light |
| 40 | 532 42 10-02 | Harness Ignition Dash/Lift |
| 41 | 817 72 04-08 | Screw 1/4-20 x 1/2 |
| 43 | 532 19 25-07 | Solenoid |
| 55 | 817 06 05-12 | Screw 5/16-18 x 3/4 |
| 71 | 532 44 08-20 | Harness Chassis/Lift Ign. |
| 79 | 532 17 52-42 | Socket Asm. |
| 83 | 532 44 09-23 | Nut Square M6 x 1 x 8.5 x 11mm |
| 87 | 532 42 10-60 | Switch Railmount |
| 102 | 532 44 12-62 | Harness Jumper |
| 105 | 532 40 75-68 | Switch Reverse |
| 107 | 532 18 03-79 | Switch Full Bagger Indicator |
| 108 | 532 42 10-62 | Switch Snapmount |

NOTE: All component dimensions given in U.S. inches
1 inch = 25.4 mm

TRACTOR - MODEL NO. M185-107TC (96051006601), PROD. NO. 960 51 00-66
CHASSIS AND ENCLOSURES **39**

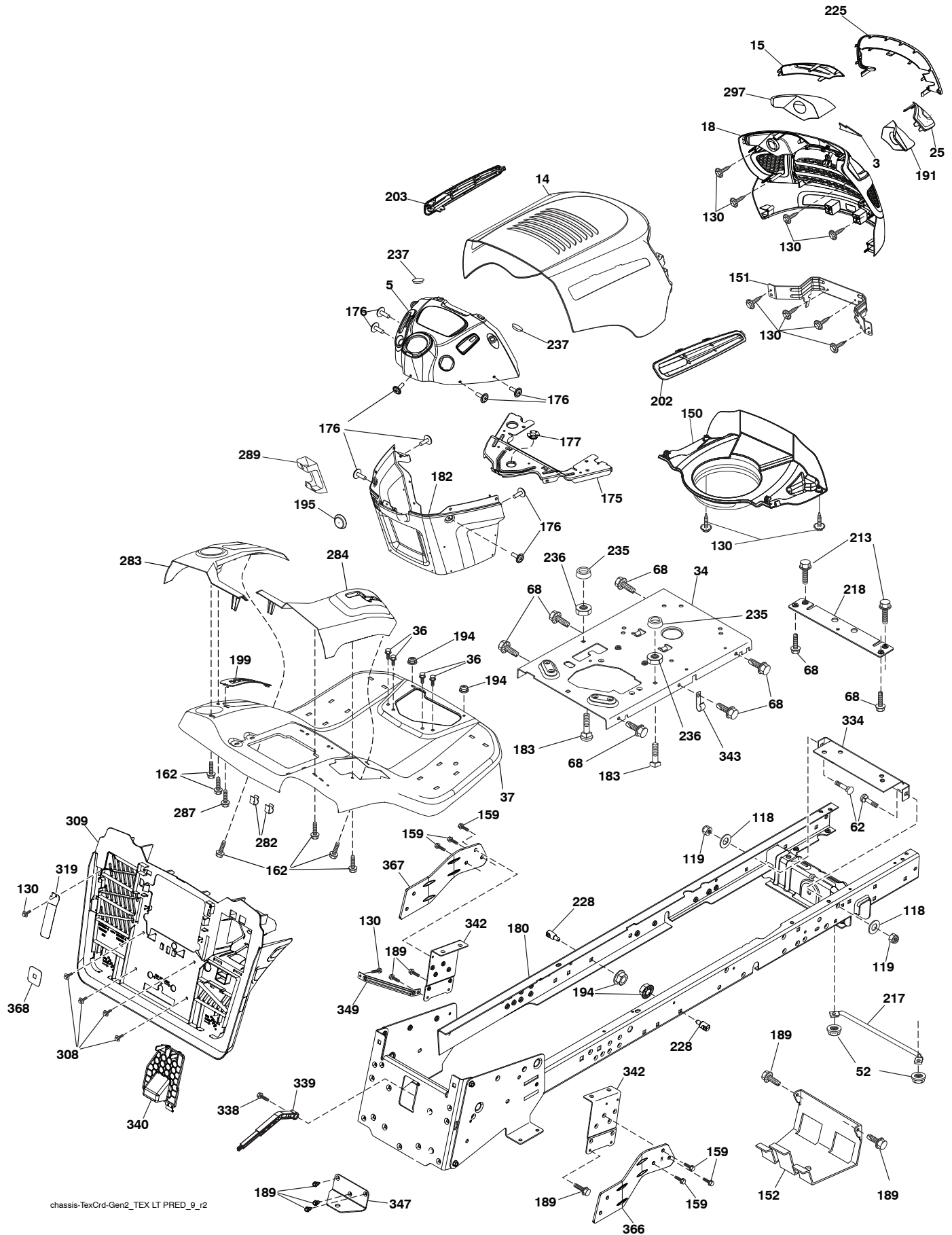

chassis-TexCrd-Gen2_TEX LT PRED_9_r2

**TRACTOR - MODEL NO. M185-107TC (96051006601), PROD. NO. 960 51 00-66
CHASSIS AND ENCLOSURES 39**

| KEY NO. | PART NO. | DESCRIPTION | KEY NO. | PART NO. | DESCRIPTION |
|------------|--------------|------------------------------------|------------|--------------|---------------------------------|
| 3 | 578 89 71-01 | Emblem Mount | 218 | 532 19 63-95 | X-Piece Hood Stop |
| 5 | 532 44 66-39 | Dash | 225 | 581 10 32-01 | Trim Ring |
| 14 | 532 44 80-42 | Hood | 228 | 532 19 51-61 | Stud Fastener |
| 15 | 581 10 31-01 | Lens LH | 235 | 532 40 61-29 | Spacer Fender |
| 18 | 581 10 29-01 | Grille | 236 | 873 93 05-00 | Nut Lock 5/16-18 unc |
| 25 | 581 10 30-01 | Lens RH | 237 | 532 40 37-04 | Plug Mount Cargo |
| 34 | 580 91 09-01 | Plate Engine | 282 | 532 41 41-10 | Clip Retainer |
| 36 | 817 06 05-12 | Screw 5/16-18 x 3/4 | 283 | 532 44 76-71 | Console Deck Lift |
| 37 | 532 43 96-24 | Fender | 284 | 532 44 72-11 | Console Shift RH |
| 52 | 873 68 05-00 | Nut Crown Lock 5/16 | 287 | 817 60 04-06 | Screw Hex Washhead 1/4-20 x 3/8 |
| 62 | 872 11 06-08 | Bolt 3/8-16 x 1 Gr. 5 | 289 | 532 40 35-71 | Plug Cruise/Phone |
| 68 | 817 49 05-08 | Screw Thdrol. 5/16-18 x 1/2 | 297 | 581 22 36-01 | Insert Reflective LH |
| 118 | 819 13 13-16 | Washer 13/32 x 13/16 x 16 Ga. | 308 | 532 17 18-77 | Bolt 5/16-18 unc x 3/4 |
| 119 | 873 68 06-00 | Nut 3/8-16 unc | 309 | 581 32 89-07 | Backplate Bagger |
| 130 | 532 41 63-58 | Screw #10 x 0.750 BOS Thread | 319 | 581 31 39-06 | Lever Bagger |
| 150 | 584 86 29-03 | Duct, Air | 334 | 532 44 25-37 | Engine Plate |
| 151 | 532 44 54-94 | Bracket Pivot Hood | 338 | 532 43 66-40 | Bolt Shoulder |
| 152 | 532 19 95-35 | Shield Browning | 339 | 532 43 66-41 | Lever Bagger Full |
| 159 | 817 00 06-12 | Screw Hexwsh Thdr 3/8-16 x 3/4 | 340 | 581 32 90-01 | Door Battery |
| 162 | 532 14 24-32 | Screw Hex Wsh. Hi-Lo 1/4 x 1/2 unc | 342 | 532 43 59-38 | Support Fender |
| 175 | 532 19 63-04 | Crossmember | 343 | 532 44 07-49 | Clip |
| 176 | 532 40 07-76 | Screw 10-24 x 5/8 | 347 | 532 44 58-32 | Hitch |
| 177 | 532 19 52-27 | Bushing Steering | 349 | 532 43 66-06 | Bracket, Support |
| 180 | 583 90 27-01 | Chassis | 366 | 581 31 46-02 | Bracket RH Front Bagger |
| 182 | 532 40 68-59 | Dash Lower | 367 | 581 31 45-02 | Bracket LH Front Bagger |
| 183 | 874 52 05-20 | Bolt 5/16-18 x 1-1/4 | 368 | 581 42 48-01 | Full Lever Bagger |
| 189 | 817 00 05-12 | Screw 5/16-18 x 3/4 | - - | 532 44 11-26 | Plug Dash |
| 191 | 581 22 35-01 | Insert Reflective RH | - - | 532 40 09-44 | Bumper |
| 194 | 873 90 05-00 | Nut Lock Hex Flange 5/16-18 | | | |
| 195 | 532 40 41-37 | Plug Hole Dash | | | |
| 199 | 532 41 87-39 | Plate Deck Lift | | | |
| 202 | 581 85 91-01 | Vent Hood RH | | | |
| 203 | 581 85 92-01 | Vent Hood LH | | | |
| 213 | 874 76 05-12 | Bolt 5/16-18 x 3/4 | | | |
| 217 | 532 40 91-67 | Rod Pivot Hood | | | |

NOTE: All component dimensions given in U.S. inches
1 inch = 25.4 mm

TRACTOR - MODEL NO. M185-107TC (96051006601), PROD. NO. 960 51 00-66
 DRIVE **40**

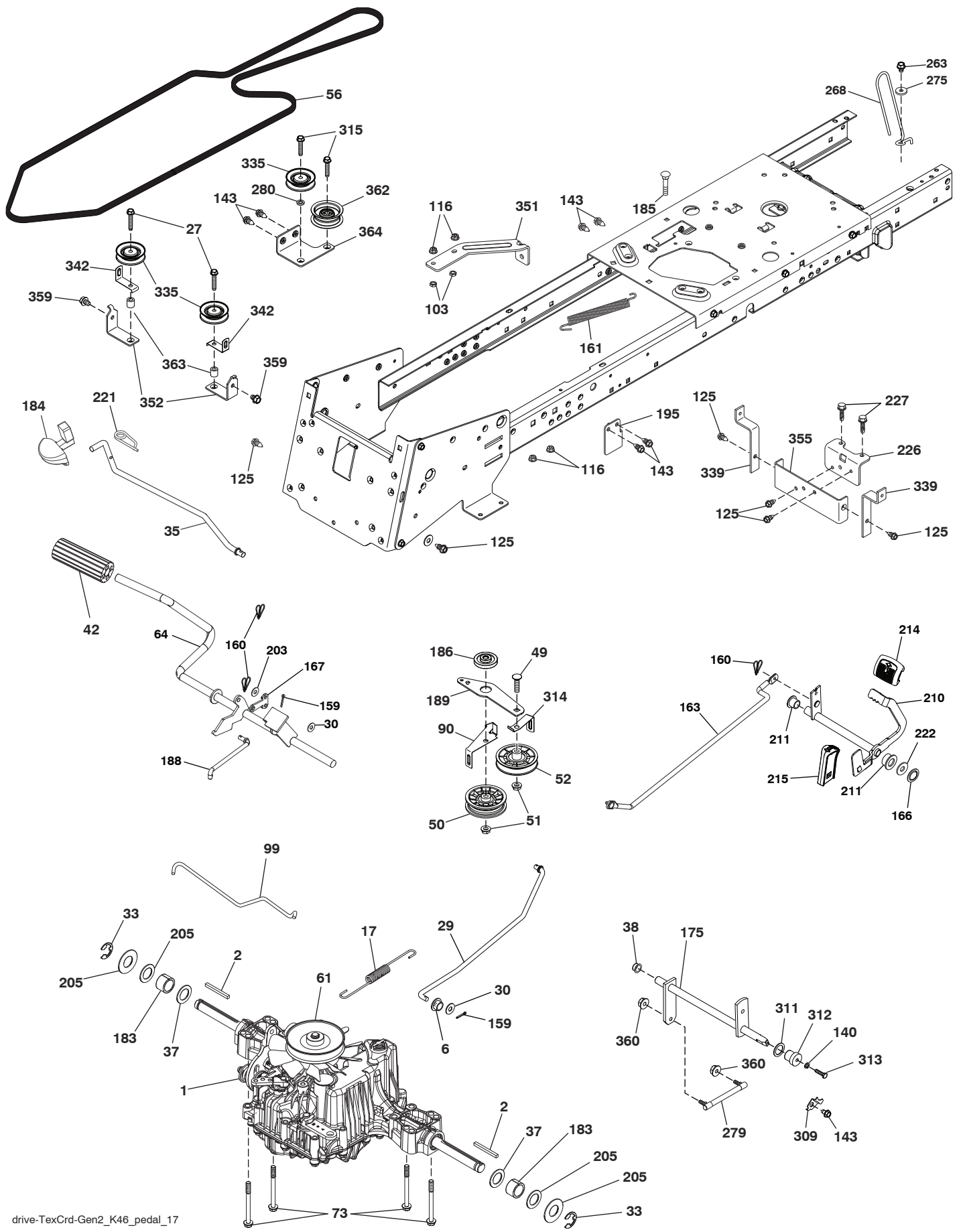

**TRACTOR - MODEL NO. M185-107TC (96051006601), PROD. NO. 960 51 00-66
DRIVE 40**

| KEY NO. | PART NO. | DESCRIPTION | KEY NO. | PART NO. | DESCRIPTION |
|------------|--------------|--|------------|--------------|---------------------------------|
| 1 | --- | Transaxle, TUFFTORQ K46DF (446488) (Order parts from trans-axle manufacturer.) | 203 | 819 11 11-16 | Washer 11/32 x 11/16 x 16 Ga. |
| 2 | 532 12 35-83 | Key Square | 205 | 532 12 17-48 | Washer 25/32 x 1-5/8 x 16 Ga. |
| 6 | 532 12 40-28 | Bushing Snap | 210 | 532 40 09-80 | Rocker Asm. Pedal Control |
| 17 | 532 43 62-27 | Spring Brake K46 | 211 | 532 12 01-83 | Bearing Nylon |
| 27 | 817 49 05-28 | ScrewHexwshThd5/16-18x1-3/4 | 214 | 532 42 12-63 | Pedal Forward |
| 29 | 532 44 27-95 | Rod, Brake | 215 | 532 41 94-82 | Pedal Reverse |
| 30 | 819 13 16-16 | Washer | 221 | 532 40 31-87 | Retainer Spring Clip Handle |
| 33 | 812 00 00-01 | Ring E | 222 | 879 21 20-10 | Washer 21/32 x 1-1/4 10 Ga. |
| 35 | 583 86 45-01 | Rod, Brake, Park | 226 | 532 40 15-64 | Bracket Strap Torque |
| 37 | 532 18 89-67 | Washer Harden 793 x 1063 x 060 | 227 | 817 49 05-12 | Screw |
| 38 | 532 16 96-13 | Nyliner Bushing | 263 | 817 00 06-12 | Screw 3/8-16 x 3/4 |
| 42 | 532 12 48-72 | Cover, Foot Pedal | 268 | 532 18 24-02 | Guard Muffler |
| 49 | 872 11 06-14 | Bolt Rdhd 3/8-16 unc x 3/4 Gr. 5 | 275 | 819 13 16-14 | Washer 13/32 x 1 x 14 |
| 50 | 532 19 43-27 | Idler Flat | 279 | 532 44 42-83 | Link Shift |
| 51 | 873 90 06-00 | Lock Nut 3/8-16 | 280 | 819 11 10-12 | Washer 11/32 x 5/8 x 12 Ga. |
| 52 | 532 19 43-26 | Idler V-Groove | 309 | 532 16 55-81 | Plate Fstnr Cross Shf |
| 56 | 532 44 27-81 | V-Belt, Drive | 311 | 532 16 98-45 | Washer Nylon |
| 61 | 532 44 51-51 | Pulley Transaxle K46 | 312 | 532 16 56-14 | Hub Tapered |
| 64 | 532 19 78-65 | Shaft Asm. Pedal Brake Control | 313 | 874 78 04-16 | Bolt Hex Fin 1/4-20 unc x 1 Gd5 |
| 73 | 874 49 05-44 | Bolt Flanged | 314 | 532 44 47-13 | Keeper Belt |
| 90 | 532 44 36-05 | Keeper Belt Clutching | 315 | 817 58 05-20 | Screw Thdrol 5/16-18 x 4.25 |
| 99 | 532 44 39-47 | Rod Spring Bypass | 335 | 532 19 95-34 | Pulley V-Idler |
| 103 | 873 35 05-00 | Nut Hex Jam 5/16-18 | 339 | 532 43 68-67 | Strap Torque K46 CRD Tex |
| 116 | 873 90 05-00 | Nut Lock Hex Flange 5/16-18 | 342 | 532 18 26-82 | Keeper Belt 2.5" STL V-Idlr CRD |
| 125 | 817 00 05-12 | Screw 5/16-18 x 3/4 | 351 | 532 43 69-98 | Bracket 97 CRD Deck Sway |
| 140 | 810 04 04-00 | Washer Lock Hvy Helical 1/4 | 352 | 532 43 56-45 | Bracket Idler CRD Tex |
| 143 | 817 49 05-08 | Screw 5/16-18 x 1/2 | 355 | 532 43 56-69 | Bracket |
| 159 | 876 02 04-12 | Pin Cotter 1/8 x 3/4 | 359 | 817 49 06-10 | Screw Thdrol 3/8-16 x 5/8 |
| 160 | 532 16 94-84 | Retainer Clip | 360 | 532 44 47-14 | Nut 5/16-24 UNF |
| 161 | 532 10 57-09 | Spring, Return, Clutch | 362 | 532 43 68-12 | Idler Flat |
| 163 | 532 44 27-93 | Rod Control | 363 | 532 44 27-80 | Spacer 343 x 63 x .62 |
| 166 | 532 42 91-64 | Nut Push | 364 | 532 44 30-32 | Bracket Idler CRD Tex |
| 167 | 532 40 52-57 | Latch Brake Parking | | | |
| 175 | 532 42 93-59 | Shaft Asm Crossshift Rear Crd | | | |
| 183 | 532 13 70-57 | Spacer Axle | | | |
| 184 | 532 44 14-55 | Handle Parking Brake | | | |
| 185 | 872 11 06-22 | Bolt 3/8-16 unc x 2-3/4 G5 | | | |
| 186 | 532 19 43-21 | Spacer Retainer | | | |
| 188 | 532 19 43-23 | Link Clutch | | | |
| 189 | 532 43 36-11 | Bellcrank Ground Drive | | | |
| 195 | 580 45 69-01 | Bracket Rod Brake CRD Tex | | | |

NOTE: All component dimensions given in U.S. inches
1 inch = 25.4 mm

TRACTOR - MODEL NO. M185-107TC (96051006601), PROD. NO. 960 51 00-66
ENGINE 24

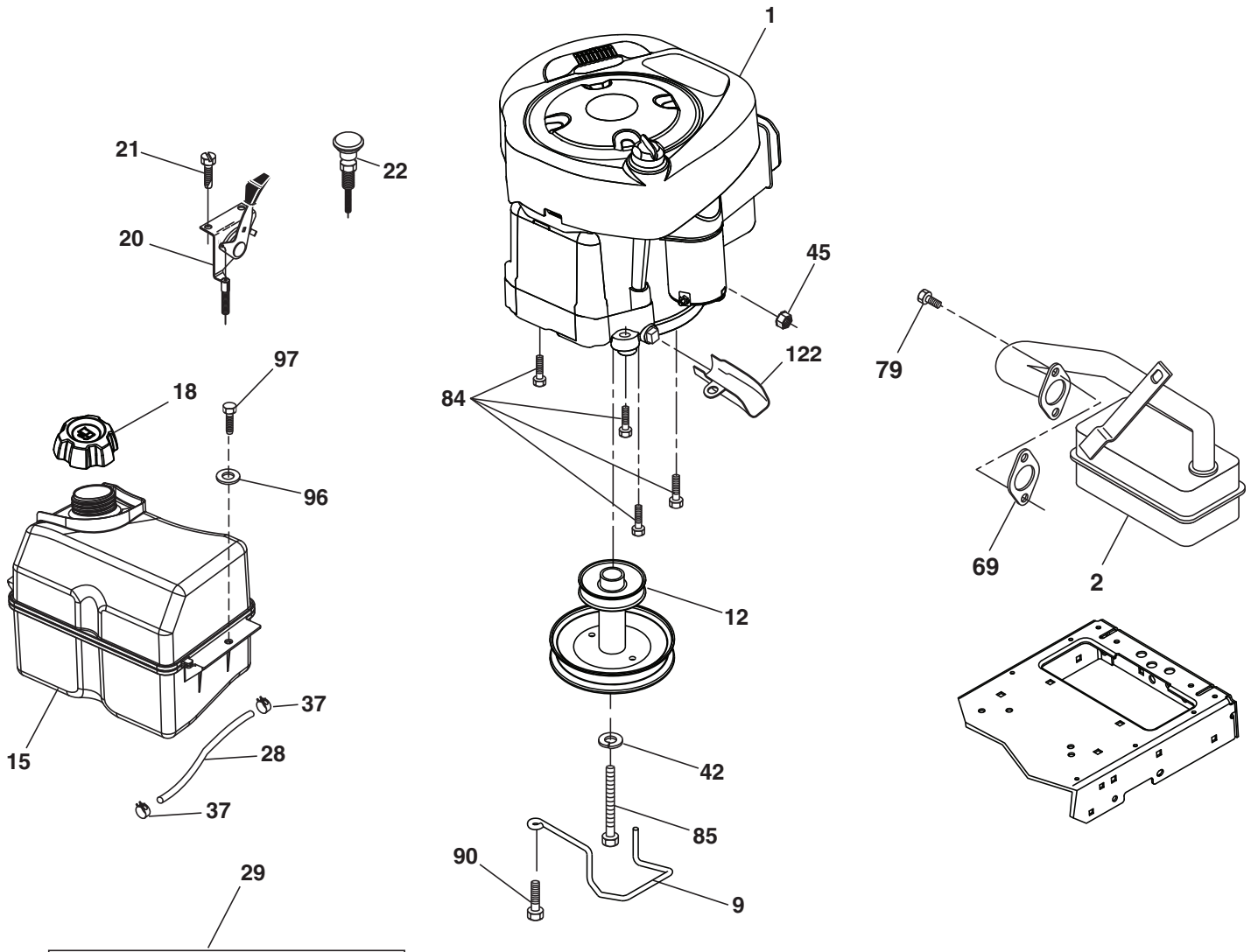

OPTIONAL EQUIPMENT
Spark Arrester

engine-tex_BS_66

**TRACTOR - MODEL NO. M185-107TC (96051006601), PROD. NO. 960 51 00-66
ENGINE 24**

| KEY NO. | PART NO. | DESCRIPTION |
|------------|--------------|---|
| 1 | ----- | Engine Briggs Model 31N707-2441-B1 (438156) (Order parts from engine manufacturer.) |
| 2 | 532 13 73-52 | Muffler |
| 9 | 532 19 43-20 | Keeper Belt Engine |
| 12 | 532 40 54-71 | Pulley Engine |
| 15 | 532 43 08-25 | Tank Fuel |
| 18 | 532 43 02-20 | Cap Fuel |
| 20 | 532 40 15-08 | Control Throttle/Choke |
| 21 | 532 41 63-58 | Screw #10 x 0.750 |
| 22 | 532 19 49-81 | Control Choke |
| 28 | 532 13 70-40 | Line Fuel |
| 29 | 532 13 71-80 | Kit Spark Arrester (Flat Scrn) |
| 37 | 532 12 34-87 | Clamp Hose Blk |
| 42 | 810 04 07-00 | Washer Lock 7/16 |
| 45 | 873 51-04-00 | Nut Keps Hex 1/4-20 unc |
| 69 | 532 16 52-91 | Gasket Muffler |
| 79 | 532 19 23-34 | Screw 5/16-18 x .75 |
| 84 | 817 06 06-20 | Screw 3/8-16 x 1-1/4 |
| 85 | 532 17 39-37 | Bolt 7/16-20 x 4 x Gr. 5-1.5 THR |
| 90 | 817 00 06-16 | Screw 3/8-16 x 1 |
| 96 | 819 09 14-16 | Washer 9/32 x 7/8 x 16 Ga. |
| 97 | 817 67 04-12 | Screw Hexwsh Thdrol 1/4-20 x 3/4 |
| 122 | 532 42 19-22 | Extension Drain Oil |

NOTE: All component dimensions given in U.S. inches
1 inch = 25.4 mm

Engine Power Rating Information

The gross power rating for individual gas engine models is labeled in accordance with SAE (Society of Automotive Engineers) code J1940 (Small Engine Power & Torque Rating Procedure), and rating performance has been obtained and corrected in accordance with SAE J1995 (Revision 2002-05). Torque values are derived at 3060 RPM; horsepower values are derived at 3600 RPM. Actual gross engine power will be lower and is affected by, among other things, ambient operating conditions and engine-to-engine variability. Given both the wide array of products on which engines are placed and the variety of environmental issues applicable to operating the equipment, the gas engine will not develop the rated gross power when used in a given piece of power equipment (actual "on-site" or net power). This difference is due to a variety of factors including, but not limited to, accessories (air cleaner, exhaust, charging, cooling, carburetor, fuel pump, etc.), application limitations, ambient operating conditions (temperature, humidity, altitude), and engine-to-engine variability. Due to manufacturing and capacity limitations, Briggs & Stratton may substitute an engine of higher rated power for this Series engine.

TRACTOR - MODEL NO. M185-107TC (96051006601), PROD. NO. 960 51 00-66
STEERING ASSEMBLY **41**

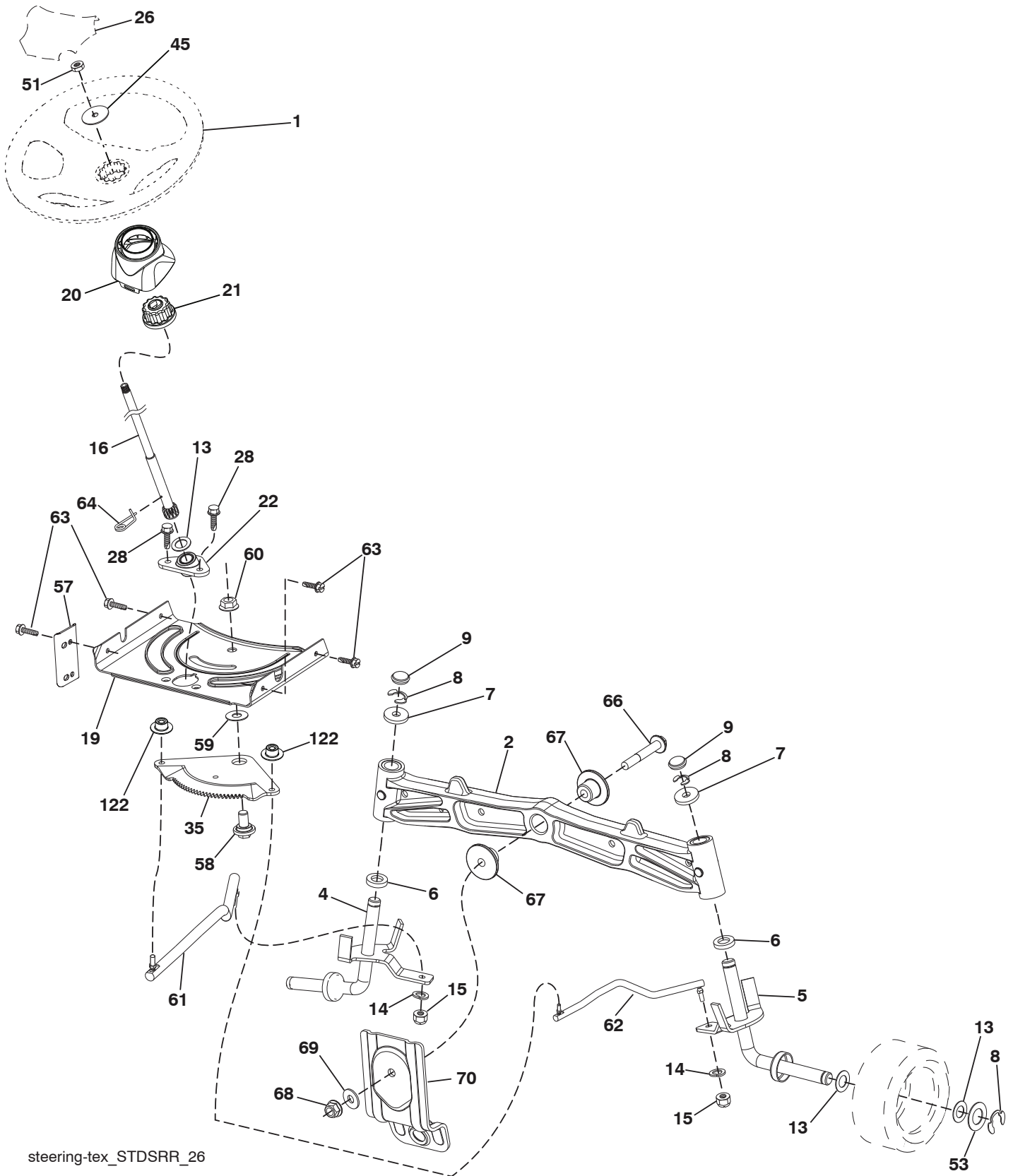

steering-tex_STDSRR_26

TRACTOR - MODEL NO. M185-107TC (96051006601), PROD. NO. 960 51 00-66
STEERING ASSEMBLY 41

| KEY NO. | PART NO. | DESCRIPTION |
|----------------|-----------------|-------------------------------------|
| 1 | 532 44 28-04 | Wheel, Steering |
| 2 | 532 19 59-68 | Axle Asm., Front |
| 4 | 532 40 30-87 | Spindle Asm., LH |
| 5 | 532 40 30-88 | Spindle Asm., RH |
| 6 | 532 12 49-31 | Bearing, Race Thrust Harden |
| 7 | 532 12 17-48 | Washer 25/32 x 1-5/8 x 16 Ga. |
| 8 | 812 00 00-29 | Ring, Klip #T5304-75 |
| 9 | 532 12 12-32 | Cap, Spindle |
| 13 | 532 12 17-49 | Washer 25/32 x 1-1/4 x 16 Ga. |
| 14 | 810 04 06-00 | Washer, Lock Hvy Hlcl Spr 3/8 |
| 15 | 873 54 06-00 | Nut, Crown Lock 3/8-24 unf |
| 16 | 532 19 47-46 | Shaft Steering |
| 19 | 532 19 47-29 | Plate Steering |
| 20 | 532 42 47-40 | Boot, Steering |
| 21 | 532 18 67-37 | Adapter, Wheel Steering |
| 22 | 532 42 05-37 | Strg. Supt. Lower |
| 26 | 532 44 77-59 | Insert, Wheel Cap |
| 28 | 817 00 06-12 | Screw 3/8-16 x 3/4 |
| 35 | 532 19 47-32 | Gear, Sector Plate |
| 45 | 819 18 38-12 | Washer 9/16 ID x 2-3/8 OD x 12 Ga. |
| 51 | 873 94 08-00 | Nut Hex Jam |
| 53 | 532 18 89-67 | Washer Hardened .793 x 1.637 x .060 |
| 57 | 532 40 74-65 | Bracket Upstop |
| 58 | 532 19 47-47 | Bolt Shoulder Sector Pivot CFM |
| 59 | 532 19 47-48 | Washer Thrust Sector Steering |
| 60 | 873 97 10-00 | Nut Flange Lock 5/8-11 |
| 61 | 532 19 47-40 | Draglink, LH |
| 62 | 532 19 47-41 | Draglink, RH |
| 63 | 817 00 05-12 | Screw 5/16-18 x 3/4 |
| 64 | 532 19 98-49 | Retainer Clip Spring Steering |
| 66 | 871 02 07-48 | Bolt Hex Fghd 7/16-14 x 3 Serr |
| 67 | 532 19 47-37 | Bushing PM Front Axle |
| 68 | 873 90 07-00 | Nut Lock Flange 7/16-14 Gr. 5 |
| 69 | 532 19 91-62 | Washer 1.5 x .505 x .118 |
| 70 | 532 19 61-97 | Bracket Deck Susp. Front |
| 122 | 532 44 49-62 | Cap Gear Sector |

NOTE: All component dimensions given in U.S. inches
1 inch = 25.4 mm

TRACTOR - MODEL NO. M185-107TC (96051006601), PROD. NO. 960 51 00-66
MOWER DECK 44

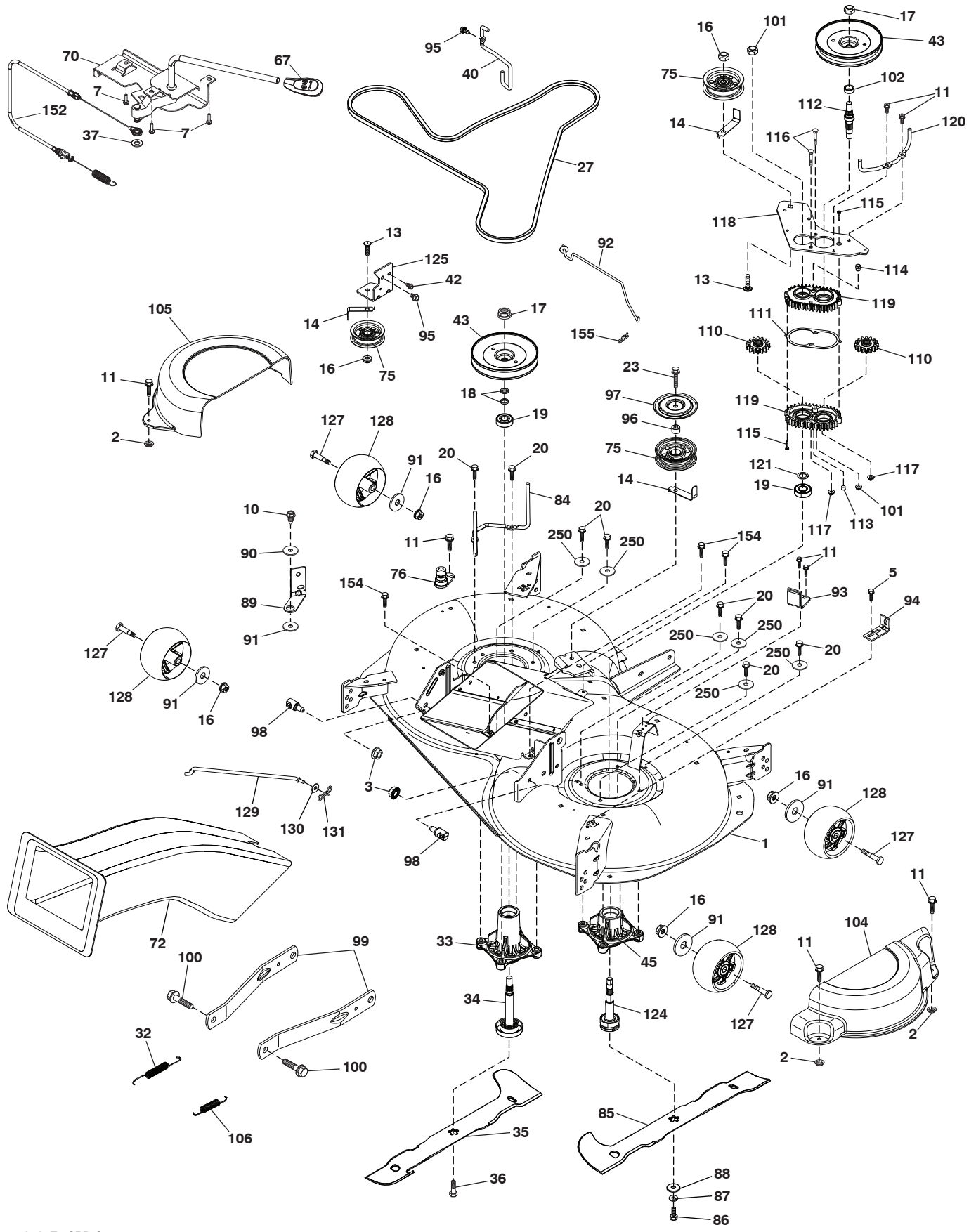

TRACTOR - MODEL NO. M185-107TC (96051006601), PROD. NO. 960 51 00-66
MOWER DECK 44

| KEY NO. | PART NO. | DESCRIPTION | KEY NO. | PART NO. | DESCRIPTION |
|---------|--------------|-----------------------------------|---------|--------------|---|
| 1 | 532 44 77-36 | Deck Weldment | 99 | 532 19 51-86 | Arm Suspension Mower Rear |
| 2 | 532 42 30-62 | Palnut | 100 | 532 19 65-39 | Bolt Shoulder |
| 3 | 873 90 05-00 | Nut Lock Hex Flange 5/16-18 | 101 | 873 68 09-00 | Nut Crownlock 9/16 - 18 unc |
| 5 | 817 00 05-10 | Bolt 5/16-18 | 102 | 532 40 25-11 | Spacer Bearing Swing Plate |
| 7 | 532 41 63-58 | Screw #10 x 0.750 BOS Thread | 104 | 581 71 40-01 | Mandrel Cover RH |
| 11 | 532 13 77-29 | Screw Thd Roll 1/4-20 X 5/8 | 105 | 532 44 47-55 | Mandrel Cover LH |
| 13 | 872 11 06-12 | Bolt Carr Sh 3/8-16 X 1-1/2 Gr. 5 | 106 | 532 19 32-16 | Spring Brake Return |
| 14 | 532 15 60-85 | Keeper Belt Idler | 110 | 532 41 53-56 | Gear Output |
| 16 | 873 90 06-00 | Nut Lock FIG 3/8 - 16 unc | 111 | 532 43 69-79 | Gasket Gearcase |
| 17 | 532 40 02-34 | Nut Flange Lock Top | 112 | 532 44 38-52 | Shaft Gearcase Adapter |
| 18 | 532 18 76-90 | Washer Spacer Mandrel | 113 | 532 43 85-33 | Plug Oil |
| 19 | 532 11 04-85 | Bearing Ball Mandrel | 114 | 532 43 85-34 | Valve Relief |
| 20 | 532 17 39-84 | Screw Thread Roll | 115 | 818 03 10-16 | Screw Torx #10-24 x 1 |
| 23 | 817 49 06-28 | Screw Thdrol 3/8-16 X 1-3/4 | 116 | 872 11 04-14 | Bolt 1/4-20 x 1.75 Gr. 5 |
| 10 | 817 00 06-16 | Screw 3/8-16 x 1 smgml tap | 117 | 873 90 04-00 | Nut Hex Flange 1/4-20 unc |
| 27 | 532 44 58-80 | V-Belt Drive | 118 | 532 44 32-32 | Arm Clutching |
| 32 | 532 40 18-72 | Spring Return Deck | 119 | 532 43 81-66 | Gearcase Subasm |
| 33 | 580 79 61-01 | Mandrel Asm. Tall | 120 | 532 44 32-36 | Keeper Belt RH |
| 34 | 580 85 47-01 | Shaft Asm Mndrel Tall | 121 | 532 43 69-85 | Washer |
| 35 | 581 51 79-01 | Blade Mower LH | 124 | 581 65 07-01 | Shaft Asm Mndrel Short |
| 36 | 532 19 30-03 | Bolt/Washer Asm 7/16-20 unf | 125 | 532 44 04-20 | Bracket Idler Chassis |
| 37 | 819 13 13-16 | Washer 13/32 x 13/16 x 16 Ga. | 127 | 532 19 34-06 | Bolt Shoulder 3/8-16 x 3-5/8 Gr. 5 |
| 40 | 532 19 72-58 | Keeper Belt Engine LH | 128 | 532 17 48-73 | Wheel Gauge |
| 42 | 817 00 05-12 | Screw 5/16-18 x 3/4 | 129 | 532 44 32-37 | Rod Anti-Sway |
| 43 | 532 44 32-39 | Pulley Mandrel | 130 | 819 13 13-12 | Washer 13/32 x 13/16 x 12 Ga. |
| 45 | 581 65 08-01 | Mandrel Asm. Short | 131 | 532 19 42-08 | Pin Cotter 5/16 Bow Tie Lock |
| 67 | 532 40 30-12 | Handle Clutch Cable | 152 | 532 44 76-66 | Cable Clutch Manual w/Spring |
| 70 | 532 19 99-72 | Clutch Asm Manual | 154 | 532 19 98-55 | Screw Thd Roll 1/4-20 x 1/2 |
| 72 | 581 45 41-01 | Chute Upper | 155 | 532 12 47-88 | Retainer Spring |
| 75 | 532 13 14-94 | Pulley Idler Flat | 250 | 819 11 12-12 | Washer 11/32 x 3/4 x 12 Ga. |
| 76 | 532 41 55-98 | Washout Port | -- | 580 85 60-01 | Mandrel Assembly-Tall(Includes Housing (key #33), Shaft Assembly (key #34), and Bearing (key #19) Only - Pulley/Nut/Washer And Blade Bolt/Washers Not Included) |
| 84 | 532 44 32-35 | Keeper Belt LH Mandrel | -- | 581 65 05-01 | Mandrel Assembly-Short(Includes Housing (key #45), Shaft Assembly (key #124), and Bearing (key #19) Only - Pulley/Nut/Washer And Blade Bolt/Washers Not Included) |
| 85 | 581 51 80-01 | Blade Mower RH | -- | 583 90 34-01 | Replacement Mower Complete |
| 86 | 532 18 17-13 | Bolt 3/8-24 x 1.50 Gr. 8 | | | |
| 87 | 810 03 06-00 | Washer Lock Hvy 3/8 | | | |
| 88 | 532 14 02-96 | Washer Hard Blade Mower Vented | | | |
| 89 | 532 19 72-61 | Arm Brake 97 LH | | | |
| 90 | 532 19 90-92 | Spacer Retainer | | | |
| 91 | 819 13 20-12 | Washer 13/32 x 1-1/4 x 12 Ga. | | | |
| 92 | 532 44 32-33 | Rod Brake Assembly | | | |
| 93 | 532 43 81-25 | Arm Brake RH | | | |
| 94 | 532 19 72-50 | Bracket Clutch Cable | | | |
| 95 | 817 00 06-12 | Screw 3/8-16 x 3/4 | | | |
| 96 | 532 40 02-71 | Spacer | | | |
| 97 | 532 18 20-61 | Shield Idler Mower | | | |
| 98 | 532 19 51-61 | Stud Fastener | | | |

NOTE: All component dimensions given in U.S. inches
1 inch = 25.4 mm

TRACTOR - MODEL NO. M185-107TC (96051006601), PROD. NO. 960 51 00-66
MOWER LIFT 45

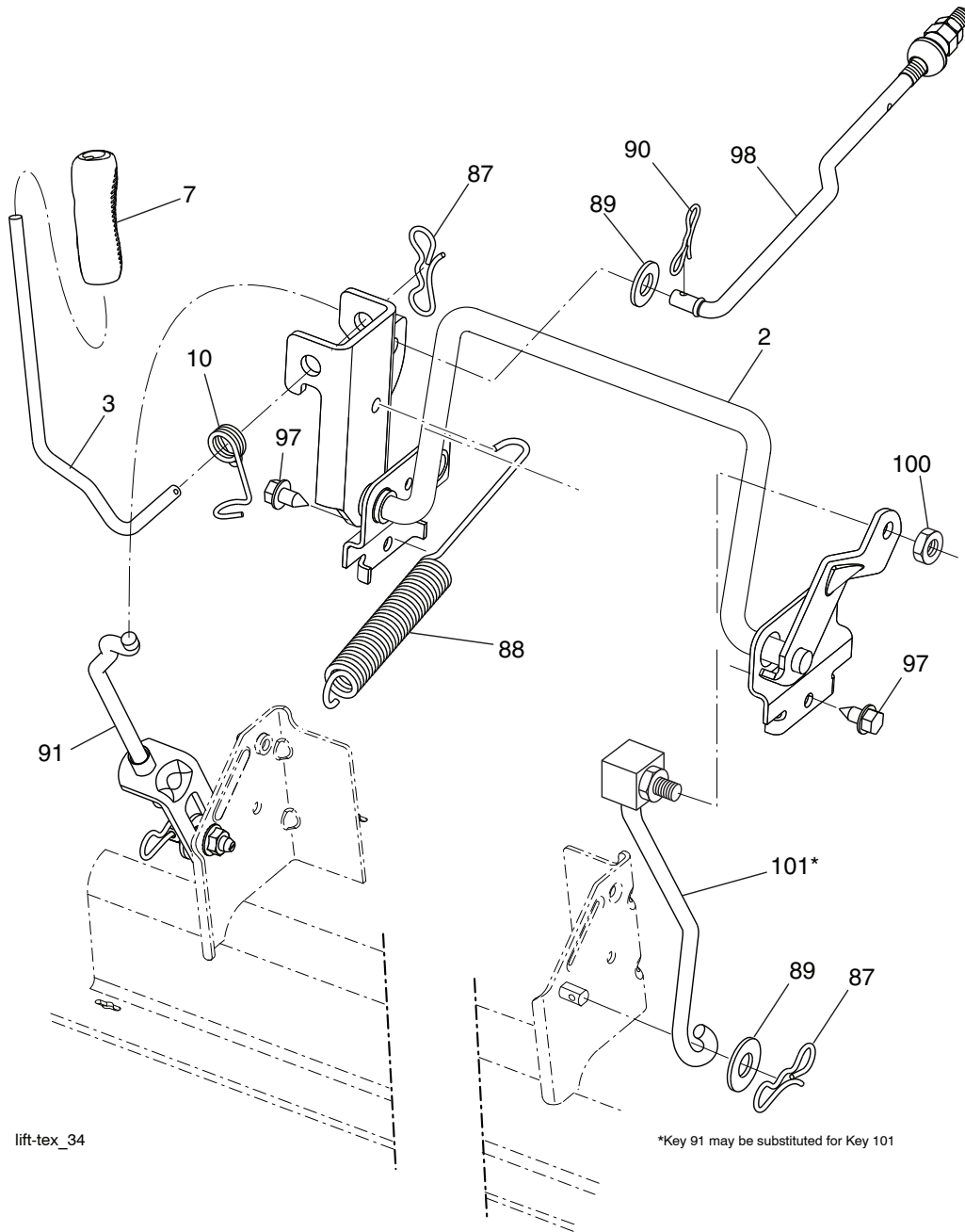

lift-tex_34

*Key 91 may be substituted for Key 101

| KEY NO. | PART NO. | DESCRIPTION |
|---------|--------------|--------------------------------|
| 2 | 532 43 69-96 | Deck Lift |
| 3 | 532 19 52-31 | Lever Asm., Lift RH |
| 7 | 580 96 23-01 | Grip, Lever |
| 10 | 532 19 63-14 | Spring Torsion |
| 87 | 532 19 42-09 | Pin Cotter 7/16 Bow Tie Lock |
| 88 | 532 44 54-96 | Spring Lift Assist |
| 89 | 819 19 19-12 | Washer 17/32 x 1-3/16 x 12 Ga. |
| 90 | 532 19 42-08 | Pin Cotter 5/16 Bow Tie Lock |

| KEY NO. | PART NO. | DESCRIPTION |
|---------|--------------|-----------------------------|
| 91 | 532 19 51-81 | Link Lift Susp Mower Rear |
| 97 | 817 49 06-08 | Screw 3/8-16 x 1/2 |
| 98 | 532 19 52-70 | Link Lift Susp. Front Mower |
| 100 | 873 93 06-00 | Nut Center Lock 3/8-16 unc |
| 101 | 532 40 70-03 | Link Asm Lift Fixed |

NOTE: All component dimensions given in U.S. inches
 1 inch = 25.4 mm

TRACTOR - MODEL NO. M185-107TC (96051006601), PROD. NO. 960 51 00-66
SEAT ASSEMBLY 42

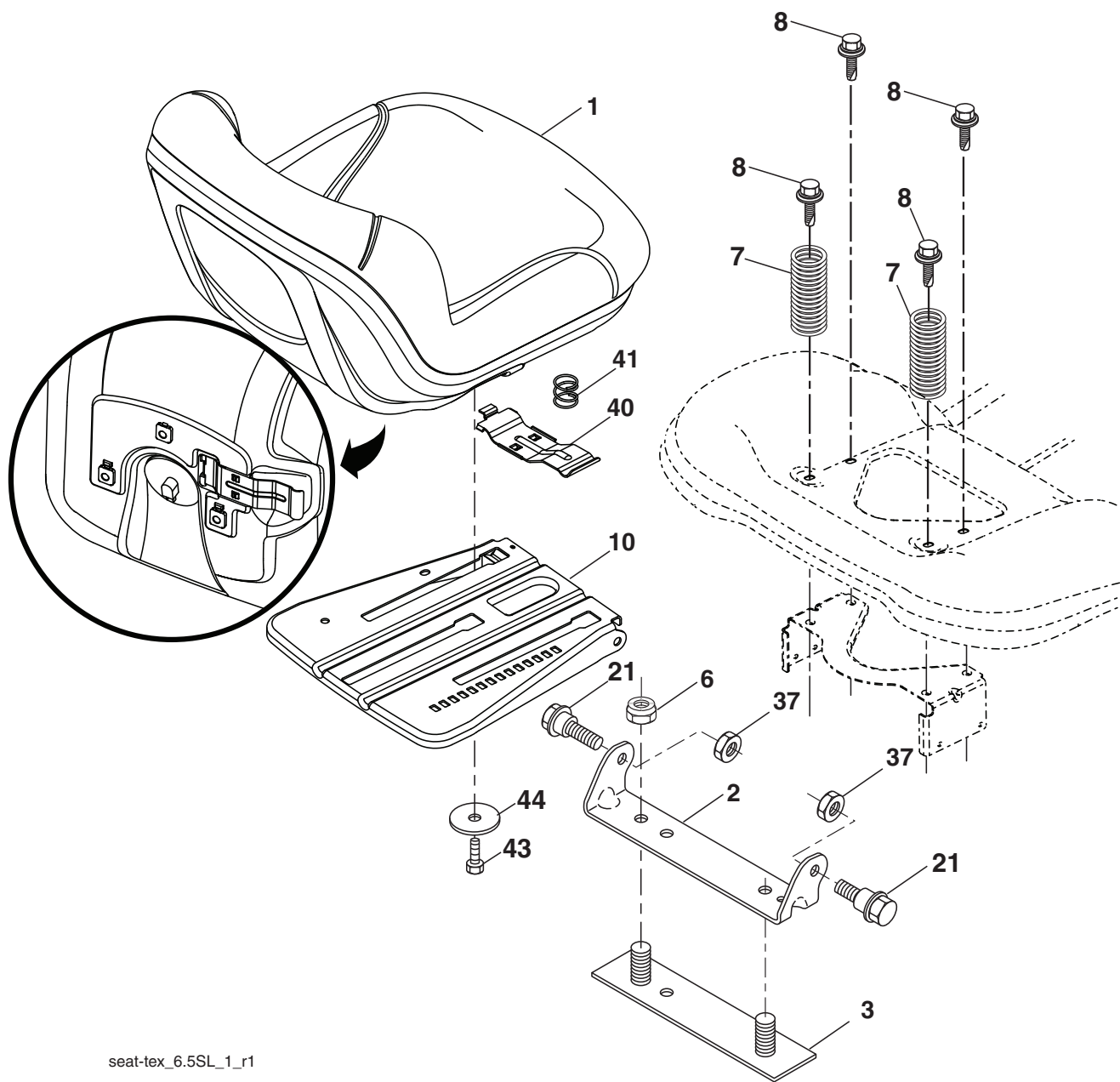

seat-tex_6.5SL_1_r1

| KEY NO. | PART NO. | DESCRIPTION |
|---------|--------------|--------------------------------|
| 1 | 581 46 22-01 | Seat |
| 2 | 532 18 01-66 | Bracket Pnt Pivot Fender |
| 3 | 532 14 06-75 | Strap |
| 6 | 873 80 06-00 | Nut Lock Hex w/Ins 3/8-16 |
| 7 | 532 12 41-81 | Spring Seat Cprsn 2 250 Blk Zi |
| 8 | 532 17 18-77 | Bolt 5/16-18 unc x 3/4 |
| 10 | 532 19 69-77 | Pan Pnt Seat |
| 21 | 532 17 18-52 | Bolt Shoulder 5/16-18 unc-2A |

| KEY NO. | PART NO. | DESCRIPTION |
|---------|--------------|-------------------------------|
| 37 | 873 80 05-00 | Nut Hex Lock w/Ins 5/16-18 |
| 40 | 532 19 76-61 | Handle Slide |
| 41 | 532 19 82-00 | Spring Latch |
| 43 | 874 76 06-12 | Bolt 3/8-16 unc x 3/4 |
| 44 | 819 13 38-12 | Washer 13/32 x 2-3/8 x 12 Ga. |

NOTE: All component dimensions given in U.S. inches
 1 inch = 25.4 mm

TRACTOR - MODEL NO. M185-107TC (96051006601), PROD. NO. 960 51 00-66
BAGGER **46**

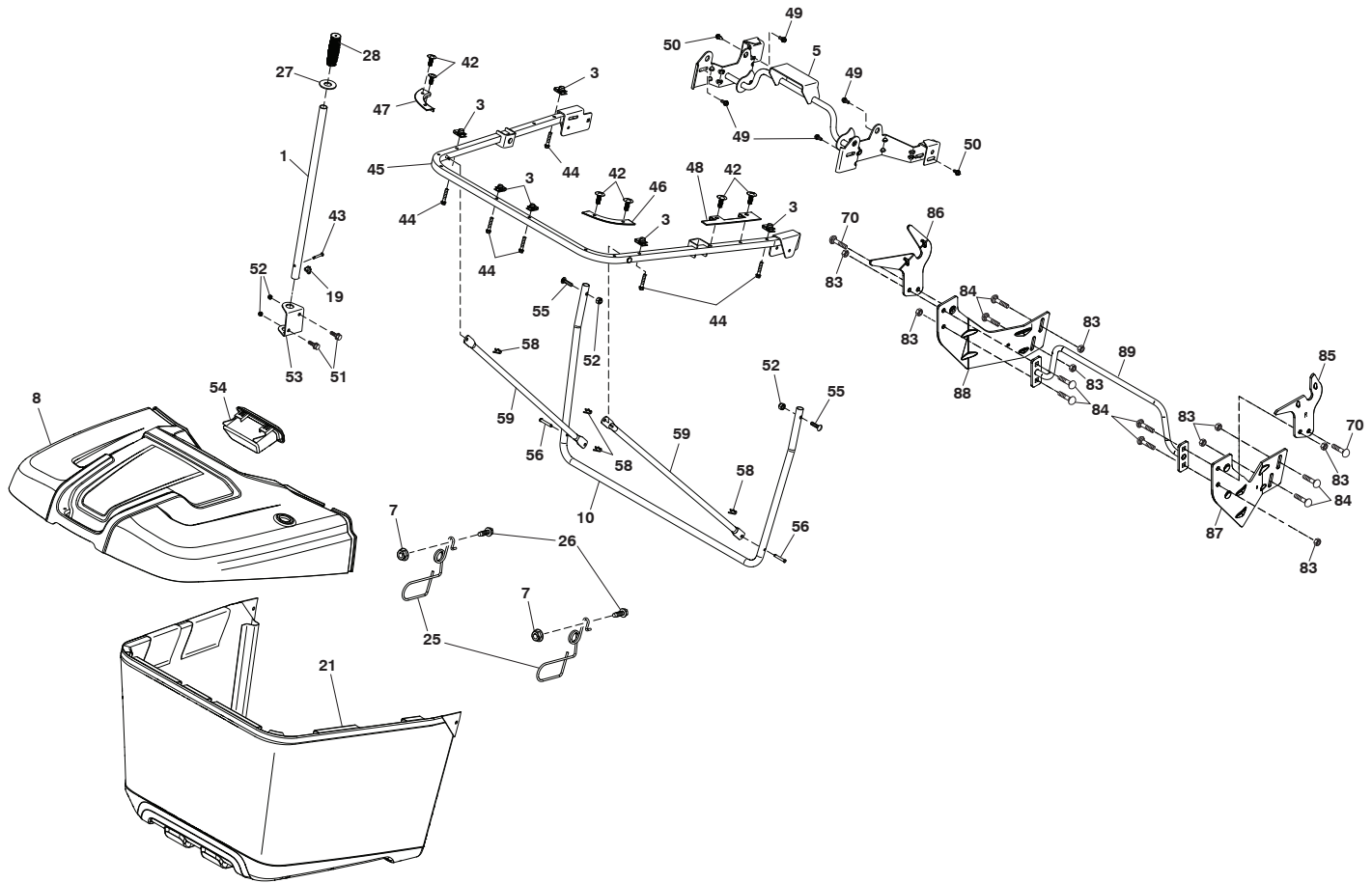

Bagger_TexCRD-Gen2_5_r2

**TRACTOR - MODEL NO. M185-107TC (96051006601), PROD. NO. 960 51 00-66
BAGGER 46**

| KEY NO. | PART NO. | DESCRIPTION |
|----------------|-----------------|----------------------------------|
| 1 | 532 42 86-10 | Tube Handle Bagger |
| 3 | 532 17 48-14 | Nut Push |
| 5 | 532 44 37-62 | Frame Asm Top Bagger |
| 7 | 873 90 04-00 | Nut Hex Flange 1/4-20 unc |
| 8 | 532 44 78-28 | Cover Bagger |
| 10 | 532 44 37-55 | Frame Front |
| 19 | 532 19 42-08 | Cotter Pin 5/16 Bow Tie |
| 21 | 581 33 71-01 | Bag Asm |
| 25 | 532 44 55-28 | Latch Bagger |
| 26 | 817 49 04-12 | Screw Hexwsh Thdrol 1 1/4~20x3/4 |
| 27 | 532 44 55-29 | Grommet Rubber |
| 28 | 532 16 57-87 | Grip Handle Black |
| 42 | 532 44 04-28 | Christmas Tree Clip |
| 43 | 532 12 68-75 | Clevis Pin |
| 44 | 532 19 96-87 | Bolt 1/4-20 1.50 |
| 45 | 532 44 37-54 | Upper U Frame Weldment |
| 46 | 532 44 55-41 | Bagger Corner Close-Out RH |
| 47 | 532 44 40-79 | Bagger Corner Close-Out LH |
| 48 | 532 44 40-80 | Top Bagger Side Close-Out |
| 49 | 532 17 18-73 | Bolt Shoulder 5/16~ 18 TT |
| 50 | 532 17 18-77 | Bolt 5/16-18 unc x 3/4 W/SEMS |
| 51 | 872 11 05-06 | Bolt RDHDSQNK 5/16-18 unc x 3/4 |
| 52 | 873 80 05-00 | Nut Lock HX W/INS 5/16-18 UNC |
| 53 | 532 44 41-95 | Bracket Dump Handle |
| 54 | 532 44 75-43 | Bagger TOP Front Handle |
| 55 | 872 14 05-12 | Bolt Rdhd Sq 5/16-18UNCX1 1/2 |
| 56 | 532 42 03-06 | Pin Clevis .1830DX1.26 long |
| 58 | 532 08 51-79 | Clip Retainer PM |
| 59 | 532 44 47-63 | Bagger Spread Tube |
| 70 | 817 00 06-12 | Bolt 3/8-16X3/4 |
| 83 | 873 80 06-00 | Nut Lock Hex w/Ins 3/8-16 |
| 84 | 872 11 06-08 | Bolt RDHD SQNK 3/8-16 x 1 Gr. 5 |
| 85 | 581 31 44-02 | Bracket RH Pivot |
| 86 | 581 31 43-02 | Bracket LH Pivot |
| 87 | 581 31 48-02 | Bracket RH |
| 88 | 581 31 47-02 | Bracket LH |
| 89 | 581 31 51-02 | Weldment Offset Strut |

NOTE: All component dimensions given in U.S. inches
1 inch = 25.4 mm

