

ILLUSTRATED PARTS LIST

MFG. ID NO. 96051007001

CUSTOMER CATALOG NO. M220-107TC

PRODUCT NO. 960 51 00-70

TRACTOR - MODEL NO. M220-107TC (96051007001), PROD. NO. 960 51 00-70
DECALS 27

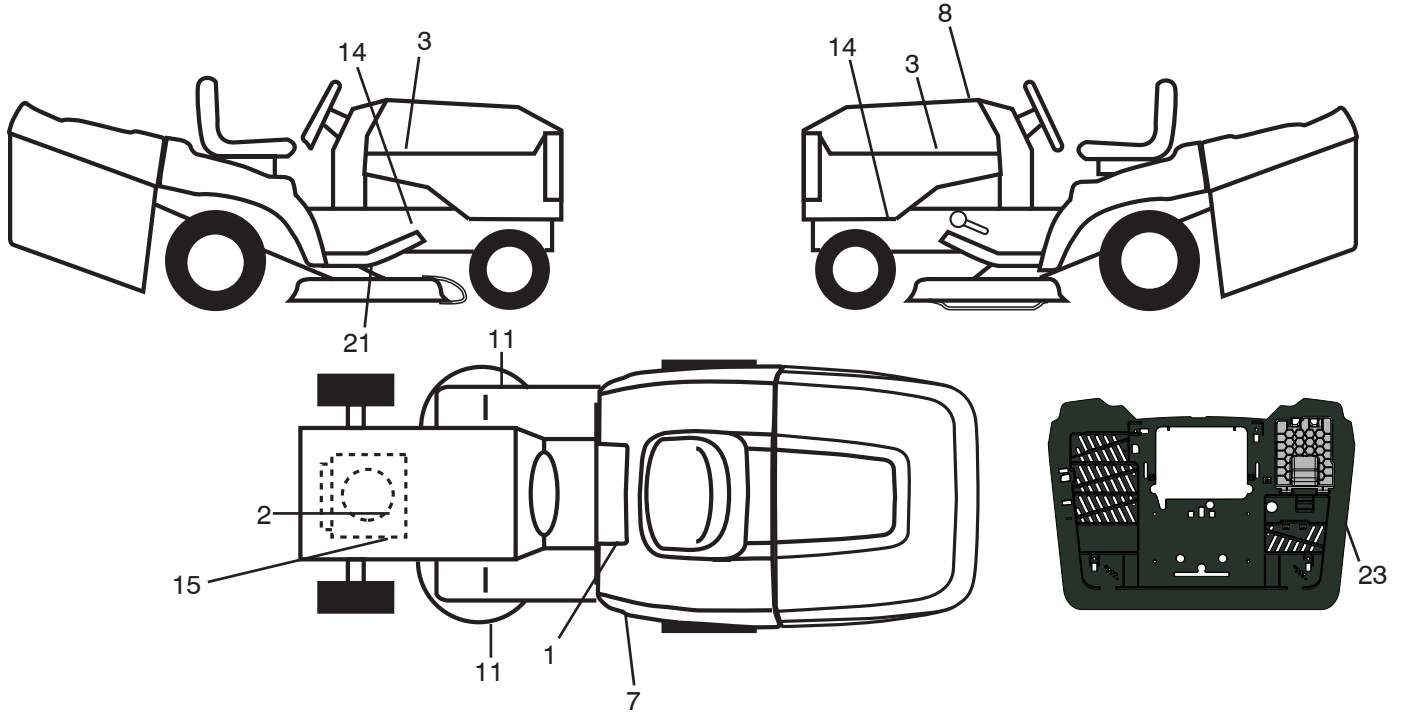

KEY NO.	PART NO.	DESCRIPTION
1	581 57 83-01	Decal, Warning
2	581 57 97-01	Decal, Warning Eng. Sym.
3	581 09 12-01	Decal, Hood RH/LH
7	581 96 48-01	Decal, Fender
8	584 23 40-01	Decal, Replacement
11	581 57 91-01	Decal, Mower Cut Finger Symbol
14	581 57 96-01	Decal, Chassis Hot Muffler
15	581 25 91-01	Decal, Engine HP

KEY NO.	PART NO.	DESCRIPTION
21	532 44 11-89	Decal, Belt Sch CRD
23	532 44 46-19	Decal, Bypass
--	532 42 59-86	Pad Footrest RH
--	532 42 59-76	Pad Footrest LH
--	584 25 51-40	Manual Operator's (Euro)
--	584 25 50-50	Manual Operator's (Scan)
--	584 25 49-20	Manual Operator's (E-Bloc)
--	584 25 48-30	Manual Operator's (Baltic)

WHEELS & TIRES

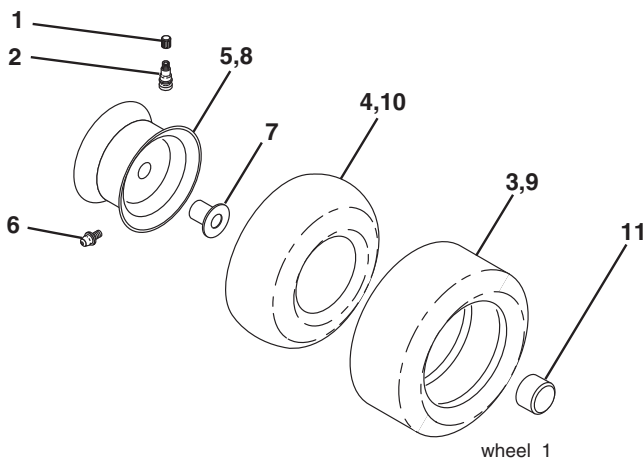

KEY NO.	PART NO.	DESCRIPTION
1	532 05 91-92	Cap Valve Tire
2	532 06 51-39	Stem Valve
3	532 10 62-22	Tire F Ts 15 x 6 0 - 6 Service
4	532 05 99-04	Tube Inner Front #35060
5	532 12 51-21	Rim Asm 6" Front Silver Service
6	532 12 49-57	Fitting Grease
7	532 12 49-59	Bearing Flange
8	532 12 51-22	Rim Asm 8" Rear Silver Service
9	532 42 05-31	Tire R.Ts-LT 18 x 9.5-8 C Ser.
10	532 12 49-26	Tube Rear 9 5 x 8 Service
11	532 19 32-68	Cap Axle
--	532 14 43-34	Sealant, Tire (10 oz. Tube)

NOTE: All component dimensions given in U.S. inches
 1 inch = 25.4 mm

**TRACTOR - MODEL NO. M220-107TC (96051007001), PROD. NO. 960 51 00-70
ELECTRICAL 32**

KEY PART NO.	PART NO.	DESCRIPTION
1	532 43 71-57	Battery
2	532 44 09-23	Screw Hex Hd Cap M6 x 1.12mm
16	532 17 61-38	Switch Interlock
21	532 40 02-52	Harness Asm Light w/4152J
22	532 00 41-52	Bulb Light #1156
25	532 44 13-82	Cable Battery Red
26	532 17 51-58	Fuse
27	873 51 04-00	Nut Keps Hex 1/4-20 unc
28	532 44 13-83	Cable Ground Black
29	532 40 15-45	Switch Seat
30	532 19 33-50	Switch Ignition
33	532 41 19-35	Key/Chain
34	532 11 07-12	Switch Light
40	532 44 80-37	Harness Ignition Dash
41	817 72 04-08	Screw 1/4-20 x 1/2
43	532 19 25-07	Solenoid
55	817 06 05-12	Screw 5/16-18 x 3/4
71	532 44 08-20	Harness Chassis
79	532 17 52-42	Socket Asm.
83	532 43 67-74	Nut Square M6 x 1 x 8.5 x 11mm
87	532 42 10-60	Switch Railmount
102	532 44 12-62	Harness Jumper
105	532 40 75-68	Switch Reverse
107	532 18 03-79	Switch Full Bagger Indicator
108	532 42 10-62	Switch Snapmount
142	583 85 78-01	Harness Charge Port
143	532 44 80-59	Charge Port

NOTE: All component dimensions given in U.S. inches
1 inch = 25.4 mm

TRACTOR - MODEL NO. M220-107TC (96051007001), PROD. NO. 960 51 00-70
CHASSIS AND ENCLOSURES **39**

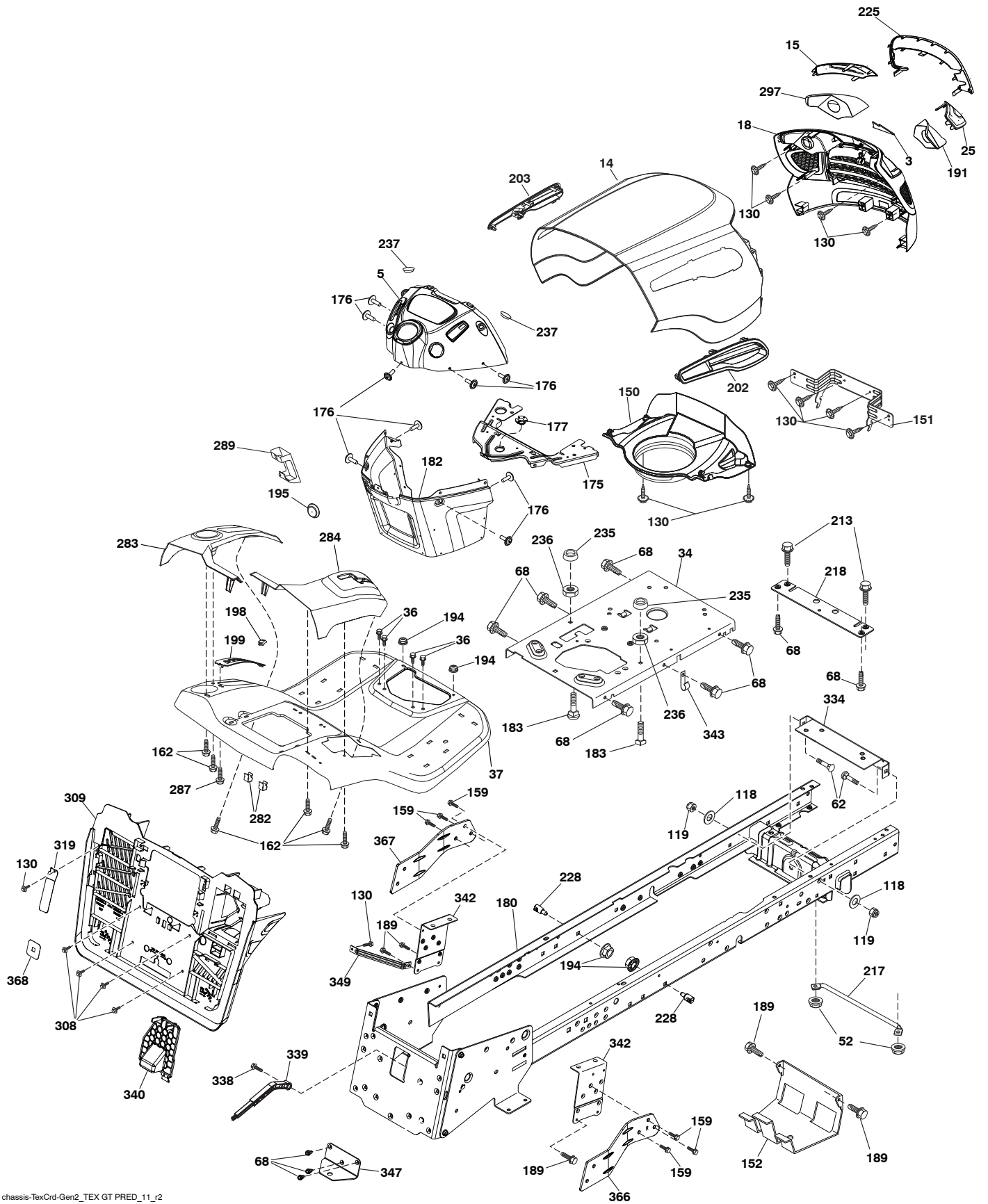

chassis-TeXCrd-Gen2_TEX GT PRED_11_r2

**TRACTOR - MODEL NO. M220-107TC (96051007001), PROD. NO. 960 51 00-70
CHASSIS AND ENCLOSURES 39**

KEY PART NO. NO.	DESCRIPTION	KEY PART NO. NO.	DESCRIPTION
3	578 89 71-01 Emblem Mount	213	874 76 05-12 Bolt 5/16-18 x 3/4
5	584 29 06-01 Dash	217	532 40 91-67 Rod Pivot Hood
14	532 44 80-42 Hood	218	532 19 63-95 X-Piece Hood Stop
15	581 10 31-01 Lens LH	225	581 10 32-01 Trim Ring
18	581 10 29-01 Grille	228	532 19 51-61 Stud Fastener
25	581 10 30-01 Lens RH	235	532 40 61-29 Spacer Fender
34	580 91 09-01 Plate Engine	236	873 93 05-00 Nut Lock 5/16-18 unc
36	817 06 05-12 Screw 5/16-18 x 3/4	237	532 40 37-04 Plug Mount Cargo
37	532 43 96-24 Fender	282	532 41 41-10 Clip Retainer
52	873 68 05-00 Nut Crown Lock 5/16	283	532 44 76-71 Console Deck Lift
62	872 11 06-08 Bolt 3/8-16 x 1 Gr. 5	284	532 44 76-72 Console Shift RH
68	817 49 05-08 Screw Thdrol. 5/16-18 x 1/2	287	817 60 04-06 Screw Hex Washhead 1/4-20 x 3/8
118	819 13 13-16 Washer 13/32 x 13/16 x 16 Ga.	289	532 40 35-71 Plug Cruise/Phone
119	873 68 06-00 Nut 3/8-16 unc	297	581 22 36-01 Insert Reflective LH
130	532 41 63-58 Screw #10 x 0.750 BOS Thread	308	532 17 18-77 Bolt 5/16-18 unc x 3/4
150	584 86 29-01 Duct, Air	309	581 32 89-07 Backplate Bagger
151	532 44 54-94 Bracket Pivot Hood	319	581 31 39-06 Lever Bagger
152	532 19 95-35 Shield Browning	334	532 44 25-37 Engine Plate
159	817 00 06-12 Screw Hexwsh Thdr 3/8-16 x 3/4	338	532 43 66-40 Bolt Shoulder
162	532 14 24-32 Screw Hex Wsh. Hi-Lo 1/4 x 1/2 unc	339	532 43 66-41 Lever Bagger Full
175	532 19 63-04 Crossmember	340	581 32 90-01 Door Battery
176	532 40 07-76 Screw 10-24 x 5/8	342	532 43 59-38 Support Fender
177	532 19 52-27 Bushing Steering	343	532 44 07-49 Clip
180	583 90 27-01 Chassis	347	532 44 58-32 Hitch
182	532 40 68-59 Dash Lower	349	532 43 66-06 Bracket, Support
183	874 52 05-20 Bolt 5/16-18 x 1-1/4	366	581 31 46-02 Bracket RH Front Bagger
189	817 00 05-12 Screw 5/16-18 x 3/4	367	581 31 45-02 Bracket LH Front Bagger
191	581 22 35-01 Insert Reflective RH	368	581 42 48-01 Full Lever Bagger
194	873 90 05-00 Nut Lock Hex Flange 5/16-18	--	532 44 11-26 Plug Dash SRVMNDR
195	532 40 41-37 Plug Hole Dash Lower	--	532 40 09-44 Kit Bumper
198	532 44 80-48 Indicator Deck Lift		
199	532 41 87-39 Plate Deck Lift		
202	581 85 91-01 Vent Hood RH		
203	581 85 92-01 Vent Hood LH		

NOTE: All component dimensions given in U.S. inches
1 inch = 25.4 mm

TRACTOR - MODEL NO. M220-107TC (96051007001), PROD. NO. 960 51 00-70
 DRIVE **40**

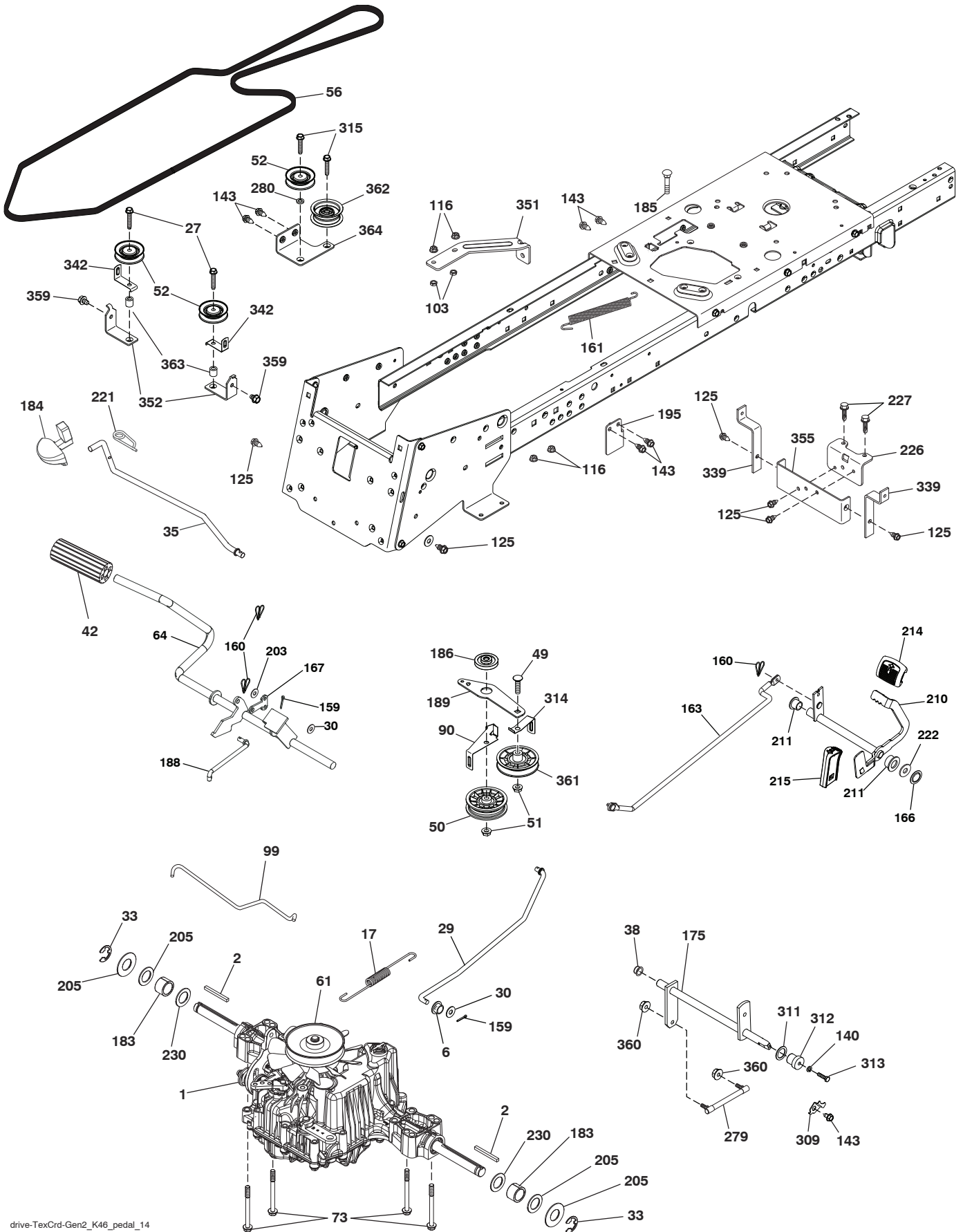

drive-TeXOrd-Gen2_K46_pedal_14

**TRACTOR - MODEL NO. M220-107TC (96051007001), PROD. NO. 960 51 00-70
DRIVE **40****

KEY PART NO.	PART NO.	DESCRIPTION	KEY PART NO.	PART NO.	DESCRIPTION
1	---	Transaxle, Tufftorq K46DF (446488) (Order parts from transaxle manufacturer.)	188	532 19 43-23	Link Clutch
2	532 12 35-83	Key Square	189	532 43 36-11	Bellcrank Ground Drive
6	532 12 40-28	Bushing Snap	195	580 45 69-01	Bracket Rod Brake CRD Tex
17	532 43 62-27	Spring Brake K46	203	819 11 11-16	Washer 11/32 x 11/16 x 16 Ga.
27	817 49 05-28	Screw 5/16-18 x 1-3/4	205	532 12 17-48	Washer 25/32 x 1-5/8 x 16 Ga.
29	532 44 27-95	Rod, Brake	210	532 40 09-80	Rocker Asm. Pedal Control
30	819 13 16-16	Washer	211	532 12 01-83	Bearing Nylon
33	812 00 00-01	Ring E	214	532 42 12-63	Pedal Forward
35	583 86 45-01	Rod, Brake, Park	215	532 41 94-82	Pedal Reverse
38	532 16 96-13	Nyliner Snap In	221	532 40 31-87	Retainer Spring Clip Handle
42	532 12 48-72	Cover, Foot Pedal	222	879 21 20-10	Washer 21/32 x 1-1/4 10 Ga.
49	872 11 06-14	Bolt 3/8-16 unc	226	532 40 15-64	Bracket Strap Torque
50	532 19 43-27	Idler Flat	227	817 49 05-12	Screw Thdrol 5/16-18 x 3/4
51	873 90 06-00	Lock Nut 3/8-16	230	532 18 89-67	Washer Hardened
52	532 19 95-34	Pulley-V-Idler.Grnd.Dr.Plated	279	532 44 42-83	Link Shift
56	532 44 27-81	V-Belt, Drive	280	819 11 10-12	Washer 11/32 x 5/8 x 12 Ga.
61	532 44 51-51	Pulley Transaxle K46	309	532 16 55-81	Plate Fstnr Cross Shf
64	532 19 78-65	Shaft Asm. Pedal Brake Control	311	532 16 98-45	Washer Nylon
73	874 49 05-44	Bolt Hex 5/16-18 x 3.75	312	532 16 56-14	Hub Tapered
90	532 44 36-05	Keeper Belt Clutching	313	874 78 04-16	Bolt Hex Fin 1/4-20 unc x 1 Gd5
99	532 44 39-47	Rod Spring Bypass	314	532 44 47-13	Retainer Belt
103	873 35 05-00	Nut Hex Jam 5/16-18 unc	315	817 58 05-20	Screw Thdrol 5/16-18 x 4.25
116	873 90 05-00	Nut Lock Hex Flange 5/16-18	339	532 43 68-67	Strap Torque K46
125	817 00 05-12	Screw 5/16-18 x 3/4	342	532 18 26-82	Keeper Belt
140	810 04 04-00	Washer Lock Hvy Helical 1/4	351	532 43 69-98	Bracket 97 CRD Deck Sway
143	817 49 05-08	Screw 5/16-18 x 1/2	352	532 43 56-45	Bracket Idler
159	876 02 04-12	Pin Cotter 1/8 x 3/4	355	532 43 56-69	Bracket
160	532 16 94-84	Retainer Clip	359	817 49 06-10	Screw Hxwsh Thdr. 3/8-16 x 5/8
161	532 10 57-09	Spring, Return, Clutch	360	532 44 47-14	Nut Hex 5/16-24
163	532 44 27-93	Rod Control	361	532 19 43-26	Idler V-Groove
166	532 42 91-64	Nut Push	362	532 43 68-12	Idler Flat
167	532 40 52-57	Latch Brake Parking	363	532 44 27-80	Spacer
175	532 42 93-59	Shaft Asm. Shift	364	532 44 30-32	Bracket Idler
183	532 13 70-57	Spacer Axle			
184	532 44 14-55	Handle Parking Brake			
185	872 11 06-22	Bolt 3/8-16 unc x 2-3/4			
186	532 19 43-21	Spacer Retainer			

NOTE: All component dimensions given in U.S. inches
1 inch = 25.4 mm

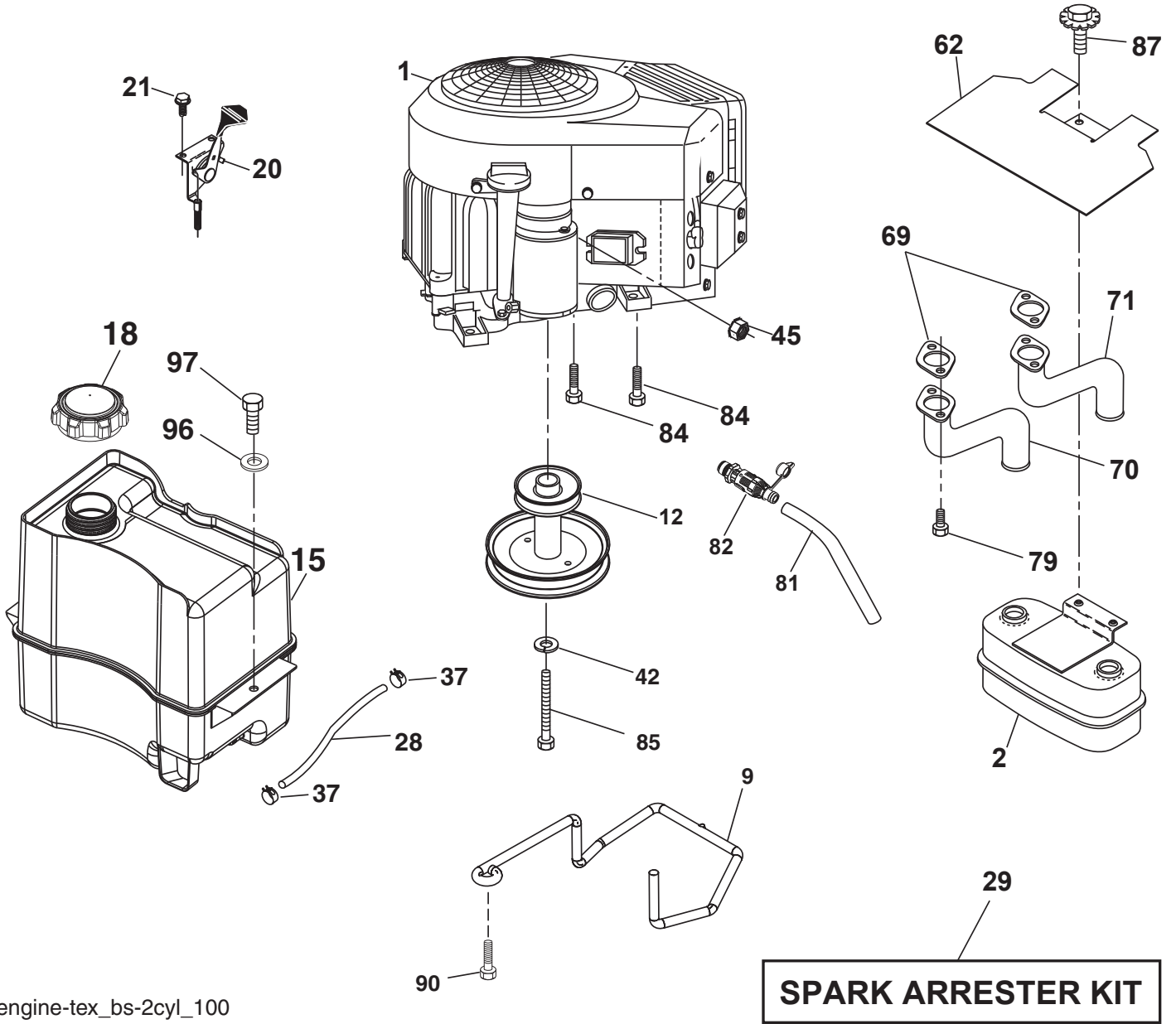

engine-tex_bs-2cyl_100

**TRACTOR - MODEL NO. M220-107TC (96051007001), PROD. NO. 960 51 00-70
ENGINE 24**

KEY PART NO.	PART NO.	DESCRIPTION
1	---	Engine Briggs Model 407777-3595-B1 (581082401) (Order parts from engine manufacturer.)
2	532 14 97-23	Muffler
9	532 19 43-20	Keeper Belt Engine
12	532 40 54-71	Pulley Engine
15	532 43 08-25	Tank Fuel
18	532 43 02-20	Cap Fuel
20	532 42 35-02	Control Throttle/Choke
21	532 41 63-58	Screw #10 x 0.750
28	532 13 70-40	Line Fuel
29	532 13 71-80	Kit Spark Arrester (Flat Scrn)
37	532 12 34-87	Clamp Hose Blk
42	810 04 07-00	Washer Lock 7/16
45	873 51-04-00	Nut Keps Hex 1/4-20 unc
62	532 43 40-17	Shield Heat
69	532 16 53-91	Gasket Muffler
70	581 88 11-01	Exhaust Tube LH
71	581 88 10-01	Exhaust Tube RH
79	532 18 39-06	Screw 5/16-18 x 1
81	532 14 84-56	Tube Drain Oil
82	532 42 82-87	Valve Oil Drain
84	817 06 06-20	Screw 3/8-16 x 1-1/4
85	532 17 39-37	Bolt 7/16-20 x 4 x Gr. 5-1.5 THR
87	532 17 18-77	Bolt 5/16-18 unc x 3/4 w/Sems
90	817 00 06-16	Screw 3/8-16 x 1
96	819 09 14-16	Washer 9/32 x 7/8 x 16 Ga.
97	817 67 04-12	Screw Hexwsh Thdrol 1/4-20 x 3/4

NOTE: All component dimensions given in U.S. inches
1 inch = 25.4 mm

Engine Power Rating Information

The gross power rating for individual gas engine models is labeled in accordance with SAE (Society of Automotive Engineers) code J1940 (Small Engine Power & Torque Rating Procedure), and rating performance has been obtained and corrected in accordance with SAE J1995 (Revision 2002-05). Torque values are derived at 3060 RPM; horsepower values are derived at 3600 RPM. Actual gross engine power will be lower and is affected by, among other things, ambient operating conditions and engine-to-engine variability. Given both the wide array of products on which engines are placed and the variety of environmental issues applicable to operating the equipment, the gas engine will not develop the rated gross power when used in a given piece of power equipment (actual "on-site" or net power). This difference is due to a variety of factors including, but not limited to, accessories (air cleaner, exhaust, charging, cooling, carburetor, fuel pump, etc.), application limitations, ambient operating conditions (temperature, humidity, altitude), and engine-to-engine variability. Due to manufacturing and capacity limitations, Briggs & Stratton may substitute an engine of higher rated power for this Series engine.

TRACTOR - MODEL NO. M220-107TC (96051007001), PROD. NO. 960 51 00-70
STEERING ASSEMBLY [41]

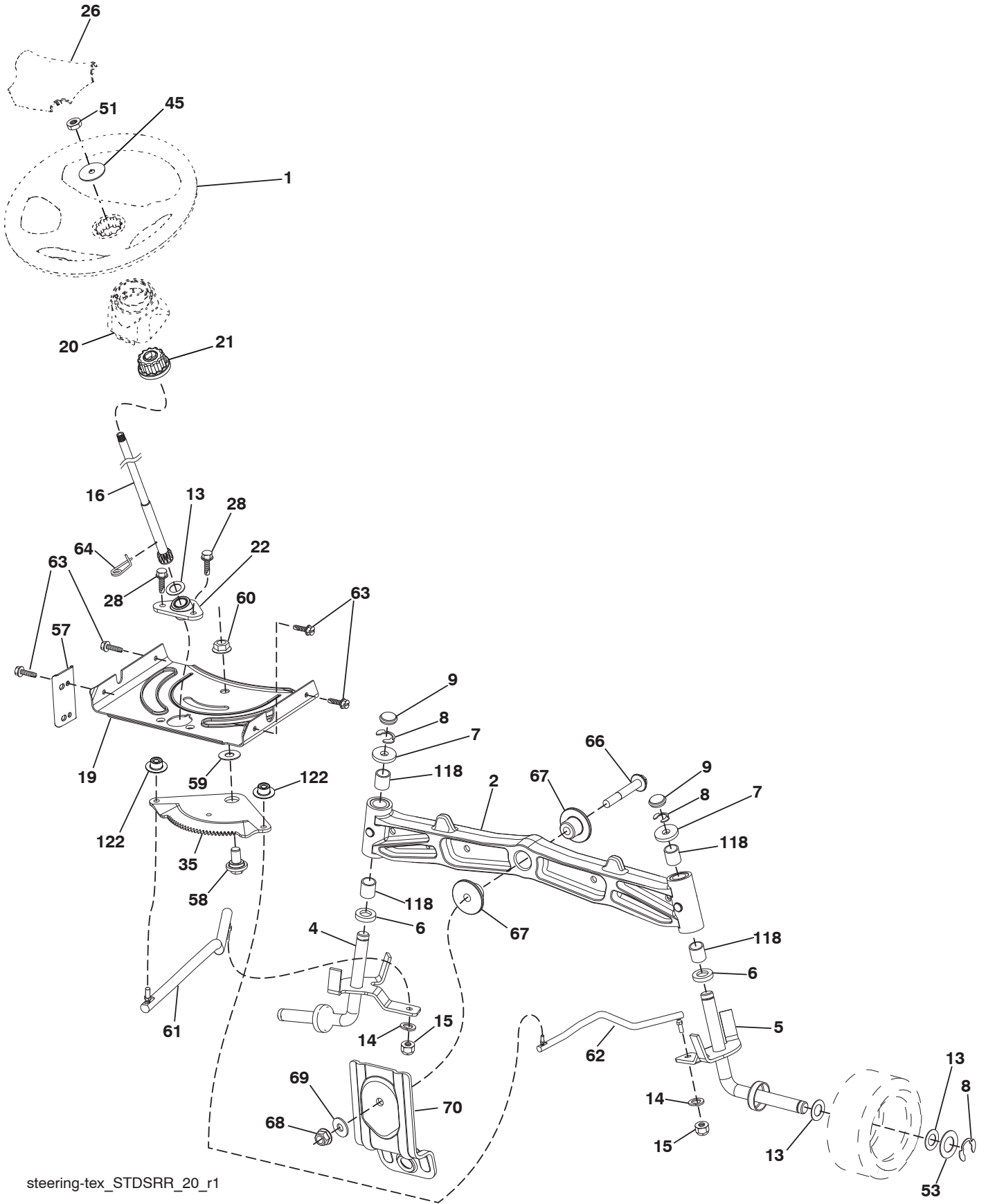

steering-tex_STDSRR_20_r1

**TRACTOR - MODEL NO. M220-107TC (96051007001), PROD. NO. 960 51 00-70
STEERING ASSEMBLY **41****

KEY NO.	PART NO.	DESCRIPTION
1	532 44 28-04	Wheel, Steering
2	532 41 35-91	Axle Asm., Front
4	532 40 30-87	Spindle Asm., LH
5	532 40 30-88	Spindle Asm., RH
6	532 12 49-31	Bearing, Race Thrust Harden
7	532 12 17-48	Washer 25/32 x 1-5/8 x 16 Ga.
8	812 00 00-29	Ring, Klip #T5304-75
9	532 12 12-32	Cap, Spindle
13	532 12 17-49	Washer 25/32 x 1-1/4 x 16 Ga.
14	810 04 06-00	Washer, Lock Hvy Hlcl Spr 3/8
15	873 54 06-00	Nut, Crown Lock 3/8-24 unf
16	532 19 47-46	Shaft Steering
19	532 19 47-29	Plate Steering
20	532 42 47-40	Boot, Steering
21	532 18 67-37	Adapter, Wheel Steering
22	532 42 05-37	Strg. Supt. Lower
26	532 44 77-59	Insert, Wheel Steering
28	817 00 06-12	Screw 3/8-16 x 3/4
35	532 19 47-32	Gear, Sector Plate
45	819 18 38-12	Washer 9/16 ID x 2-3/8 OD 12 GZIN
51	873 94 08-00	Nut Hex Jam Toplock 1/2-20 unf
53	532 18 89-67	Washer Hardened .793 x 1.637 x .060
57	532 40 74-65	Bracket Upstop
58	532 19 47-47	Bolt Shoulder Sector Pivot CFM
59	532 19 47-48	Washer Thrust Sector Steering
60	873 97 10-00	Nut Flange Lock 5/8-11
61	532 19 47-40	Draglink, LH
62	532 19 47-41	Draglink, RH
63	817 00 05-12	Screw 5/16-18 x 3/4
64	532 19 98-49	Retainer Clip Spring Steering
66	871 02 07-48	Bolt Hex Fghd 7/16-14 x 3 Serr
67	532 19 47-37	Bushing PM Front Axle
68	873 90 07-00	Nut Lock Flange 7/16-14 Gr. 5
69	532 19 91-62	Washer 1.5 x .505 x .118
70	532 19 61-97	Bracket Deck Susp. Front
118	532 40 60-13	Bushing
122	532 44 49-62	Cap Gear Sector

NOTE: All component dimensions given in U.S. inches
1 inch = 25.4 mm

TRACTOR - MODEL NO. M220-107TC (96051007001), PROD. NO. 960 51 00-70
MOWER DECK 44

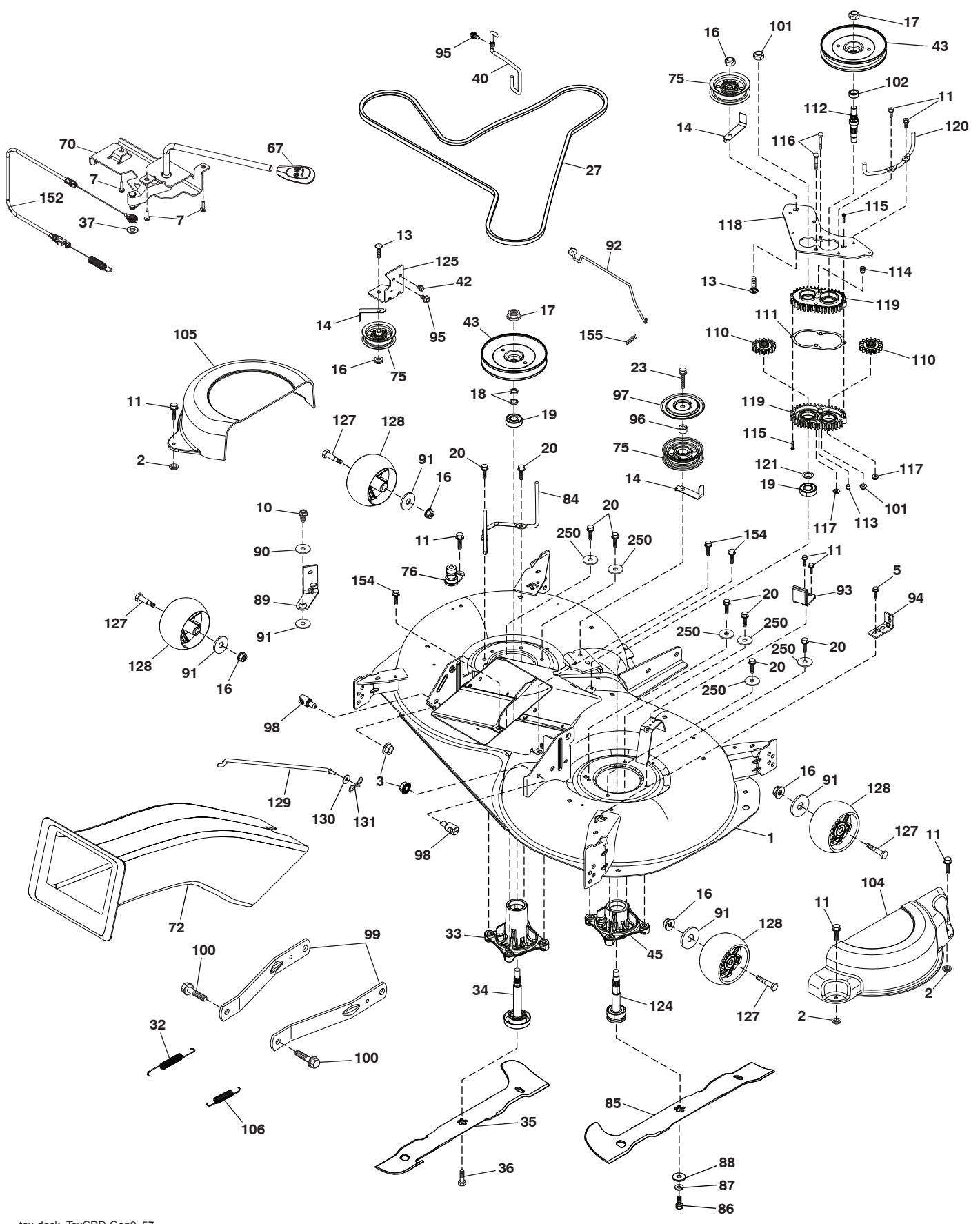

TRACTOR - MODEL NO. M220-107TC (96051007001), PROD. NO. 960 51 00-70
MOWER DECK 44

KEY NO.	PART NO.	DESCRIPTION	KEY NO.	PART NO.	DESCRIPTION
1	532 44 77-36	Deck Weldment	100	532 19 65-39	Bolt Shoulder
2	532 42 30-62	Pal Nut	101	873 68 09-00	Nut Crownlock 9/16 - 18 unc
3	873 90 05-00	Nut Lock Hex Flange 5/16 - 18	102	532 40 25-11	Spacer Bearing Swing Plate
5	817 00 05-10	Bolt 5/16-18	104	581 71 40-01	Mandrel Cover RH
7	532 41 63-58	Screw #10 x 0.750 BOS Thread	105	532 44 47-55	Mandrel Cover LH
10	817 00 06-16	Screw 3/8-16x1 smgml tap	106	532 19 32-16	Spring Brake Return
11	532 13 77-29	Screw Thd Roll 1/4 - 20 X 5/8	110	532 41 53-56	Gear Output
13	872 11 06-12	Bolt Carr Sh 3/8 - 16 X 1-1/2 Gr. 5	111	532 43 69-79	Gasket Gearcase
14	532 15 60-85	Keeper Belt Idler	112	532 44 38-52	Shaft Gearcase Adapter
16	873 90 06-00	Nut Lock FIG 3/8 - 16 unc	113	532 43 85-33	Plug Oil
17	532 40 02-34	Nut Flange Lock Top	114	532 43 85-34	Valve Relief
18	532 18 76-90	Washer Spacer Mandrel	115	818 03 10-16	Screw Torx #10-24 x 1
19	532 11 04-85	Bearing Ball Mandrel	116	872 11 04-14	Bolt 1/4-20 x 1.75 Gr. 5
20	532 17 39-84	Screw Thread Roll	117	873 90 04-00	Nut Hex Flange 1/4-20 unc
23	817 49 06-28	Screw Thdrol 3/8 - 16 X 1-3/4	118	532 44 32-32	Arm Clutching
27	532 44 58-80	V-Belt Drive	119	532 43 81-66	Gearcase Subasm
32	532 40 18-72	Spring Return Deck	120	532 44 32-36	Keeper Belt RH
33	580 79 61-01	Mandrel Asm. Tall	121	532 43 69-85	Washer
34	580 85 47-01	Shaft Asm	124	581 65 07-01	Sub Asm. Reverse Thread
35	581 51 79-01	Blade Mower LH	125	532 44 04-20	Bracket Idler Chassis
36	532 19 30-03	Bolt/Washer Asm 7/16 - 20 unf	127	532 19 34-06	Bolt Shoulder 3/8-16 x 3-5/8 Gr. 5
37	819 13 13-16	Washer 13/32 x 13/16 x 16 Ga.	128	532 17 48-73	Wheel Gauge
40	532 19 72-58	Keeper Belt Engine LH	129	532 44 32-37	Rod Anti-Sway
42	817 00 05-12	Screw 5/16-18 x 3/4	130	819 13 13-12	Washer 13/32 x 13/16 x 12 Ga.
43	532 44 32-39	Pulley Mandrel	131	532 19 42-08	Pin Cotter 5/16 Bow Tie Lock
45	581 65 08-01	Mandrel Asm. Short	152	532 44 76-66	Cable Clutch Manual w/Spring
67	532 40 30-12	Handle Clutch Cable	154	532 19 98-55	Screw Thd Roll 1/4-20 x 1/2
70	532 19 99-72	Clutch Asm Manual	155	532 12 47-88	Retainer Spring 1"
72	581 45 41-01	Chute Upper	250	819 11 12-12	Washer 11/32 x 3/4 x 12 Ga.
75	532 13 14-94	Pulley Idler Flat	--	580 85 60-01	Mandrel Assembly tall (Includes Housing Assembly (key#33), Shaft Assembly (key#34) and Bearing Only (key#19) - Pulley/ Nut/Washer And Blade Bolt/Washers Not Included)
76	532 41 55-98	Washout Port	--	581 65 05-01	Mandrel Assembly Short (Includes Housing Assembly (key#45), Shaft Assembly (key#124) and Bearing Only (key#19) - Pulley/ Nut/Washer And Blade Bolt/Washers Not Included)
84	532 44 32-35	Keeper Belt LH Mandrel	--	583 90 34-01	Replacement Mower Complete
85	581 51 80-01	Blade Mower RH			
86	532 18 17-13	Bolt 3/8-24 x 1.50 Gr. 8			
87	810 03 06-00	Washer Lock Hvy. 3/8			
88	532 14 02-96	Washer Hard			
89	532 19 72-61	Arm Brake 97 LH			
90	532 19 90-92	Spacer Retainer			
91	819 13 20-12	Washer 13/32 x 1-1/4 x 12 Ga.			
92	532 44 32-33	Rod Brake Assembly			
93	532 43 81-25	Arm Brake RH			
94	532 19 72-50	Bracket Clutch Cable			
95	817 00 06-12	Screw 3/8-16 x 3/4			
96	532 40 02-71	Spacer			
97	532 18 20-61	Shield Idler Mower			
98	532 19 51-61	Stud Fastener			
99	532 19 51-86	Arm Suspension Mower Rear			

NOTE: All component dimensions given in U.S. inches
1 inch = 25.4 mm

TRACTOR - MODEL NO. M220-107TC (96051007001), PROD. NO. 960 51 00-70
MOWER LIFT 45

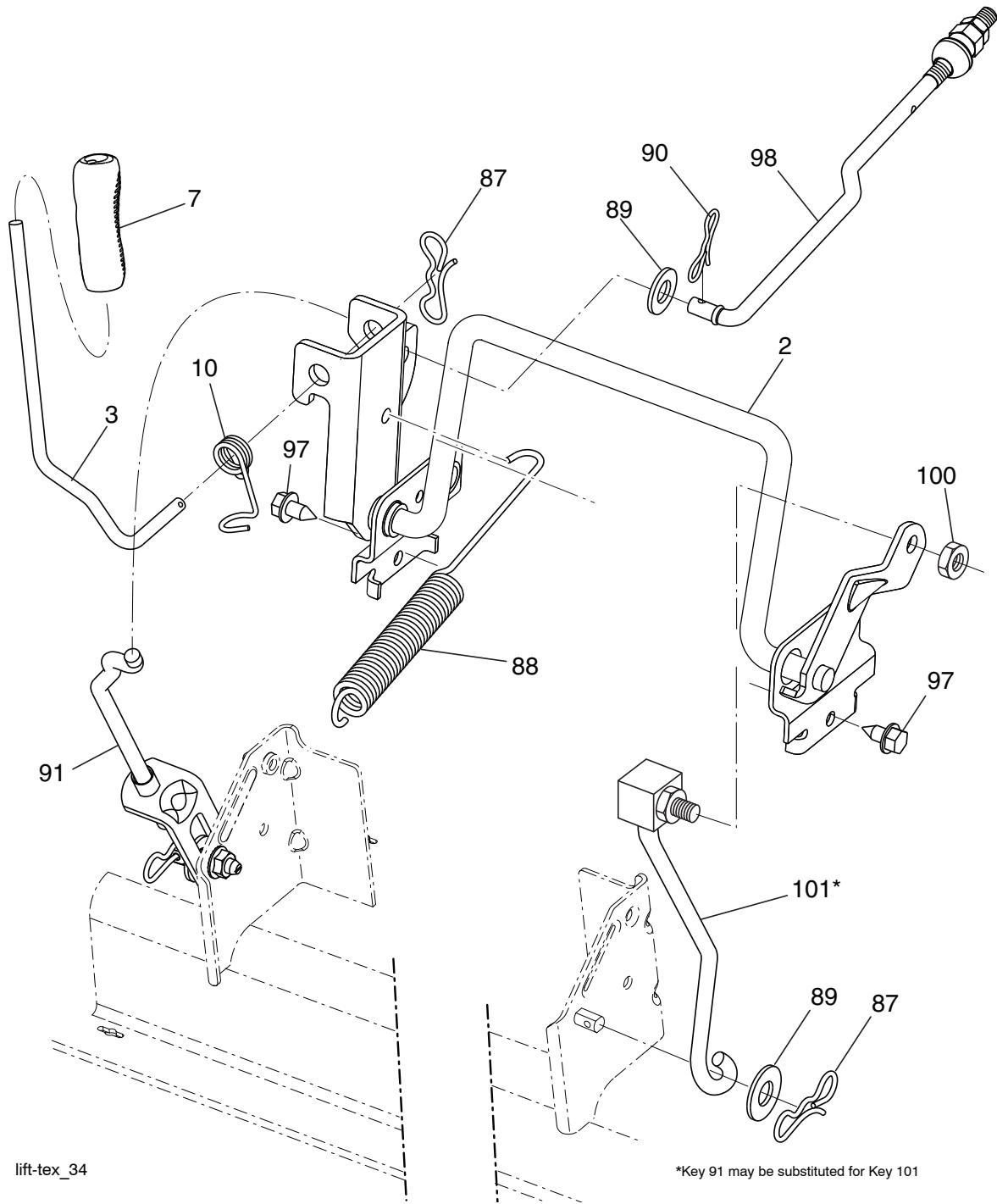

lift-tex_34

*Key 91 may be substituted for Key 101

KEY NO.	PART NO.	DESCRIPTION
2	532 43 69-96	Deck Lift
3	532 19 52-31	Lever Asm., Lift RH
7	580 96 23-01	Grip, Lever
10	532 19 63-14	Spring Torsion
87	532 19 42-09	Pin Cotter 7/16 Bow Tie Lock
88	532 44 54-96	Spring Lift Assist
89	819 19 19-12	Washer 17/32 x 1-3/16 x 12 Ga.
90	532 19 42-08	Pin Cotter 5/16 Bow Tie Lock

KEY NO.	PART NO.	DESCRIPTION
91	532 19 51-81	Link Lift Susp Mower Rear
97	817 49 06-08	Screw 3/8-16 x 1/2
98	532 19 52-70	Link Lift Susp. Front Mower
100	873 93 06-00	Nut Centerlock 3/8-16 unc
101	532 40 70-03	Link Asm. Lift Fixed

NOTE: All component dimensions given in U.S. inches
 1 inch = 25.4 mm

TRACTOR - MODEL NO. M220-107TC (96051007001), PROD. NO. 960 51 00-70
SEAT ASSEMBLY 42

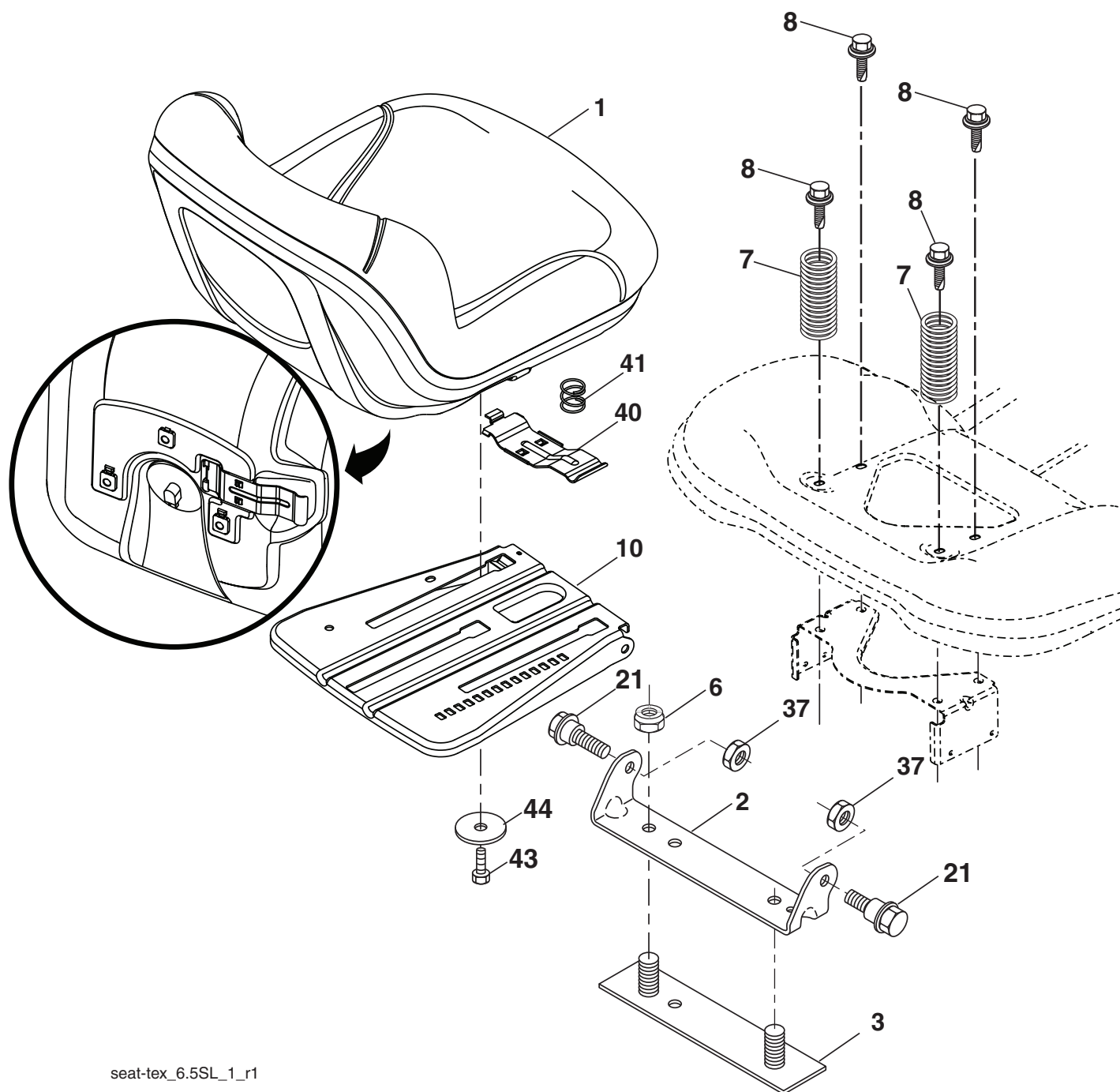

seat-tex_6.5SL_1_r1

KEY PART NO.	PART NO.	DESCRIPTION
1	581 46 22-02	Seat
2	532 18 01-66	Bracket Pnt Pivot Fender
3	532 14 06-75	Strap
6	873 80 06-00	Nut Lock Hex w/Ins 3/8-16
7	532 12 41-81	Spring Seat Cprsn 2 250 Blk Zi
8	532 17 18-77	Bolt 5/16-18 unc x 3/4
10	532 19 69-77	Pan Pnt Seat
21	532 17 18-52	Bolt Shoulder 5/16-18 unc-2A

KEY PART NO.	PART NO.	DESCRIPTION
37	873 80 05-00	Nut Hex Lock w/Ins 5/16-18
40	532 19 76-61	Handle Slide
41	532 19 82-00	Spring Latch
43	874 76 06-12	Bolt 3/8-16 unc x 3/4
44	819 13 38-12	Washer 13/32 x 2-3/8 x 12 Ga.

NOTE: All component dimensions given in U.S. inches
 1 inch = 25.4 mm

**TRACTOR - MODEL NO. M220-107TC (96051007001), PROD. NO. 960 51 00-70
BAGGER 46**

KEY NO.	PART NO.	DESCRIPTION
1	532 42 86-10	Tube Handle Bagger
3	532 17 48-14	Nut Push
5	532 44 37-62	Frame Asm Top Bagger
7	873 90 04-00	Nut Hex Flange 1/4-20 unc
8	532 44 78-28	Cover Bagger
10	532 44 37-55	Frame Front
19	532 19 42-08	Cotter Pin 5/16 Bow Tie
21	581 33 71-01	Bag Asm
25	532 44 55-28	Latch Bagger
26	817 49 04-12	Screw Hexwsh Thdrol 1 1/4~20 x 3/4
27	532 44 55-29	Grommet Rubber
28	532 16 57-87	Grip Handle Black
42	532 44 04-28	Christmas Tree Clip
43	532 12 68-75	Clevis Pin
44	532 19 96-87	Bolt 1/4-20 1.50
45	532 44 37-54	Upper U Frame Weldment
46	532 44 55-41	Bagger Corner Close-Out RH
47	532 44 40-79	Bagger Corner Close-Out LH
48	532 44 40-80	Top Bagger Side Close-Out
49	532 17 18-73	Bolt Shoulder 5/16~ 18 TT
50	532 17 18-77	Bolt 5/16-18 unc x 3/4 W/SEMS
51	872 11 05-06	Bolt RDHDSQNK 5/16-18 unc x 3/4
52	873 80 05-00	Nut Lock HX W/INS 5/16-18 UNC
53	532 44 41-95	Bracket Dump Handle
54	532 44 75-43	Bagger TOP Front Handle
55	872 14 05-12	Bolt Rdhd Sq 5/16-18UNCX1 1/2
56	532 42 03-06	Pin Clevis .1830DX1.26 long
58	532 08 51-79	Clip Retainer PM
59	532 44 47-63	Bagger Spread Tube
70	817 00 06-12	Bolt 3/8-16X3/4
83	873 80 06-00	Nut Lock Hex w/Ins 3/8-16
84	872 11 06-08	Bolt RDHD SQNK 3/8-16 x 1 Gr. 5
85	581 31 44-02	Bracket RH Pivot
86	581 31 43-02	Bracket LH Pivot
87	581 31 48-02	Bracket RH
88	581 31 47-02	Bracket LH
89	581 31 51-02	Weldment Offset Strut Sup

NOTE: All component dimensions given in U.S. inches
1 inch = 25.4 mm

