

# **ILLUSTRATED PARTS LIST**

**MODEL NO. 96041029601**

**CUSTOMER CATALOG NO. M185-117T**

**PRODUCT NO. 960 41 02-96**

**TRACTOR -- MODEL NO. M185-117T (96041029601), PRODUCT NO. 960 41 02-96  
DECALS 27**

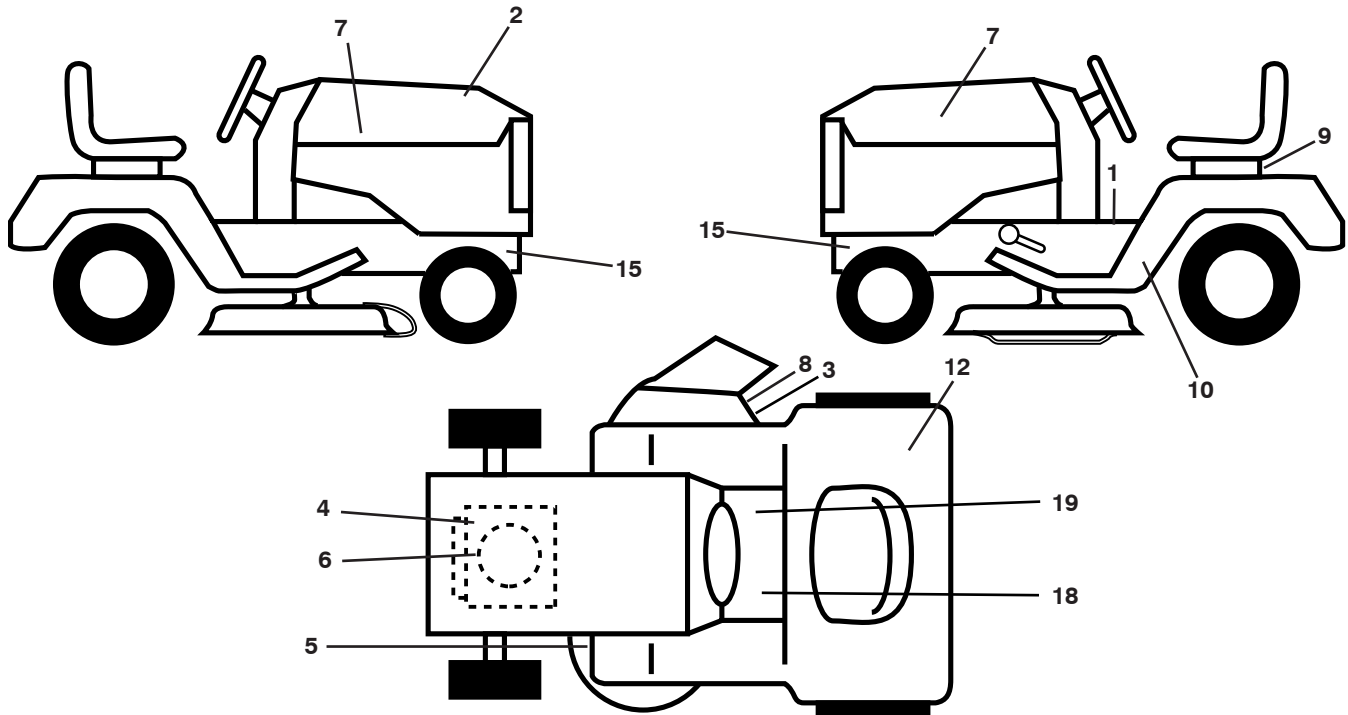

KEY NO.	PART NO.	DESCRIPTION
1	581 57 81-01	Decal, Warning Sym.
2	584 22 05-01	Decal, RPL
3	581 57 92-01	Decal, Warning
4	581 57 97-01	Decal, Warning Engine
5	581 58 00-01	Decal, V-Belt Sch.
6	532 43 74-20	Decal, Eng. HP
7	581 09 12-01	Decal, Hood LH/RH
8	581 57 91-01	Decal, Cutfinger
9	532 14 50-05	Decal, Battery Dnge/Poi
10	581 53 32-01	Decal, Fender Side
12	581 72 41-01	Decal, Fender DB

KEY NO.	PART NO.	DESCRIPTION
15	581 57 96-01	Decal, Hot Muffler
18	581 72 40-01	Decal, Clutch/Brake
19	581 57 80-01	Decal, Saddle Brake Parking
--	581 72 48-01	Decal, Bypass
--	581 72 46-01	Decal, Load Limit
--	532 40 95-05	Pad, Footrest, LH
--	532 40 95-07	Pad, Footrest, RH
--	584 24 34-40	Manual, Oper Euro
--	584 24 34-50	Manual, Oper Scand
--	584 24 34-20	Manual, Oper E-Bloc
--	584 24 34-30	Manual, Oper Baltic

**WHEELS AND TIRES**

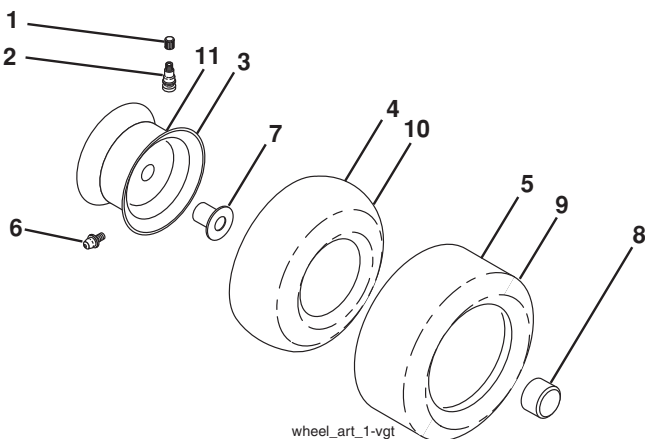

KEY NO.	PART NO.	DESCRIPTION
1	532 05 91-92	Cap, Valve, Tire
2	532 06 51-39	Stem, Valve
3	532 12 51-21	Rim Assembly, Front
4	532 05 99-04	Tube, Front (Service Item Only)
5	532 10 62-22	Tire, Front
6	532 12 49-57	Fitting, Grease (Front Wheel Only)
7	532 12 49-59	Bearing, Flange (Front Wheel Only)
8	532 19 32-68	Cap, Axle
9	532 13 84-68	Tire, Rear
10	532 12 49-26	Tube, Rear (Service Item Only)
11	532 12 51-22	Rim Assembly, Rear
--	532 14 43-34	Sealant, Tire (10 oz. Tube)

**NOTE:** All component dimensions given in U.S. inches  
1 inch = 25.4 mm

# TRACTOR - - MODEL NO. M185-117T (96041029601), PRODUCT NO. 960 41 02-96

## SCHEMATIC 38

SCH11

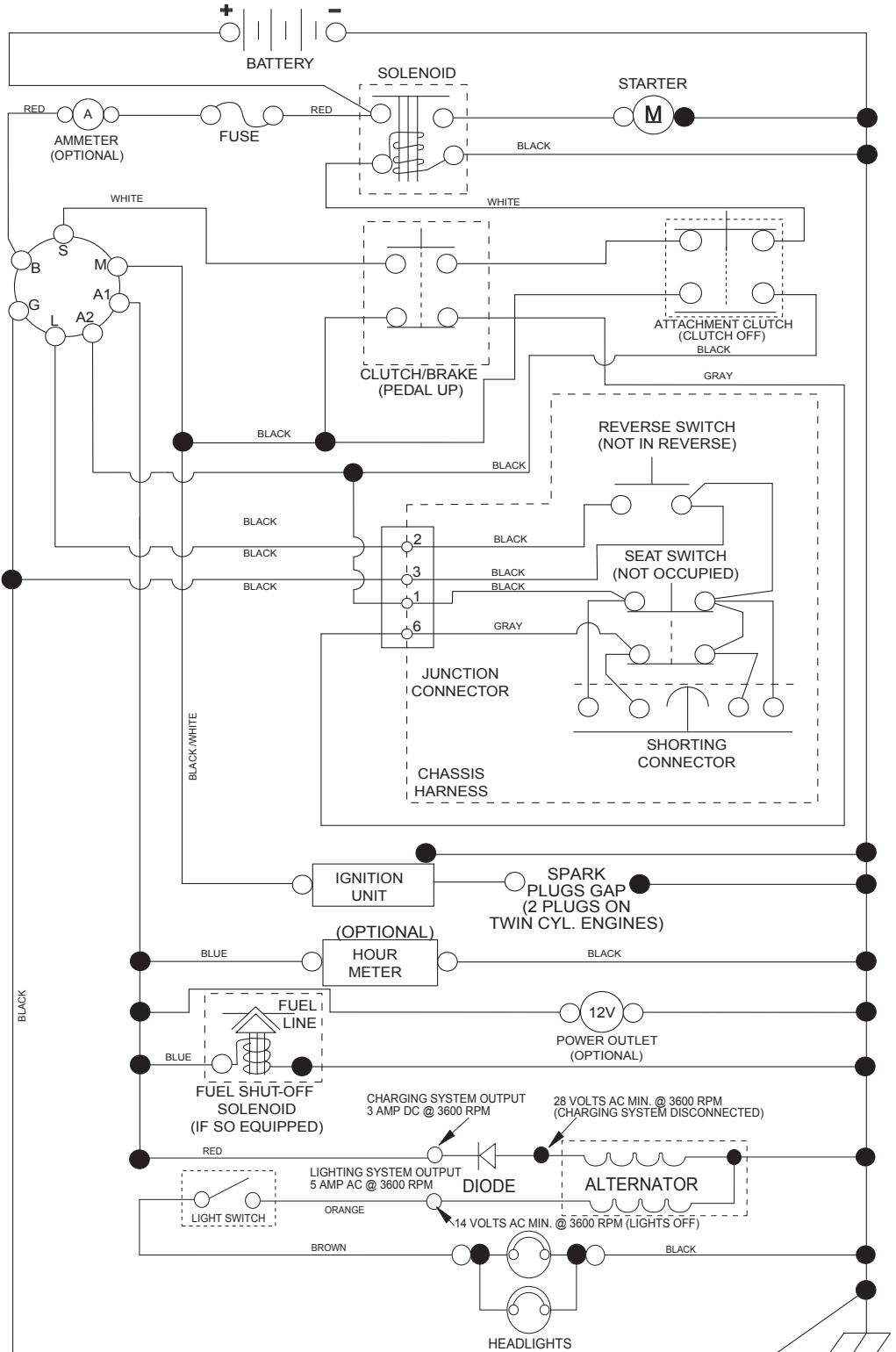

**NOTE**  
YOUR TRACTOR IS EQUIPPED WITH A SPECIAL ALTERNATOR SYSTEM. THE LIGHTS ARE NOT CONNECTED TO THE BATTERY, BUT HAVE THEIR OWN ELECTRICAL SOURCE. BECAUSE OF THIS, THE BRIGHTNESS OF THE LIGHTS WILL CHANGE WITH ENGINE SPEED. AT IDLE THE LIGHTS WILL DIM. AS THE ENGINE IS SPEEDED UP, THE LIGHTS WILL BECOME THEIR BRIGHTEST.

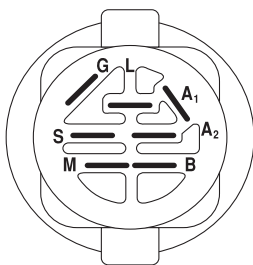

IGNITION SWITCH

POSITION	CIRCUIT	"MAKE"
OFF	M+G+A1	
RUN/OVERRIDE	B+A1	
RUN	B+A1	L+A2
START	B + S + A1	

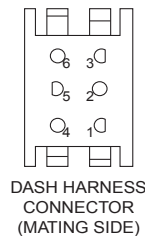
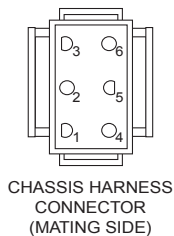

WIRING INSULATED CLIPS  
NOTE: IF WIRING INSULATED CLIPS WERE REMOVED FOR SERVICING OF UNIT, THEY SHOULD BE RE-INSTALLED TO PROPERLY SECURE YOUR WIRING.

NON-REMOVABLE CONNECTIONS  
REMOVABLE CONNECTIONS

TRACTOR -- MODEL NO. M185-117T (96041029601), PRODUCT NO. 960 41 02-96  
ELECTRICAL **32**

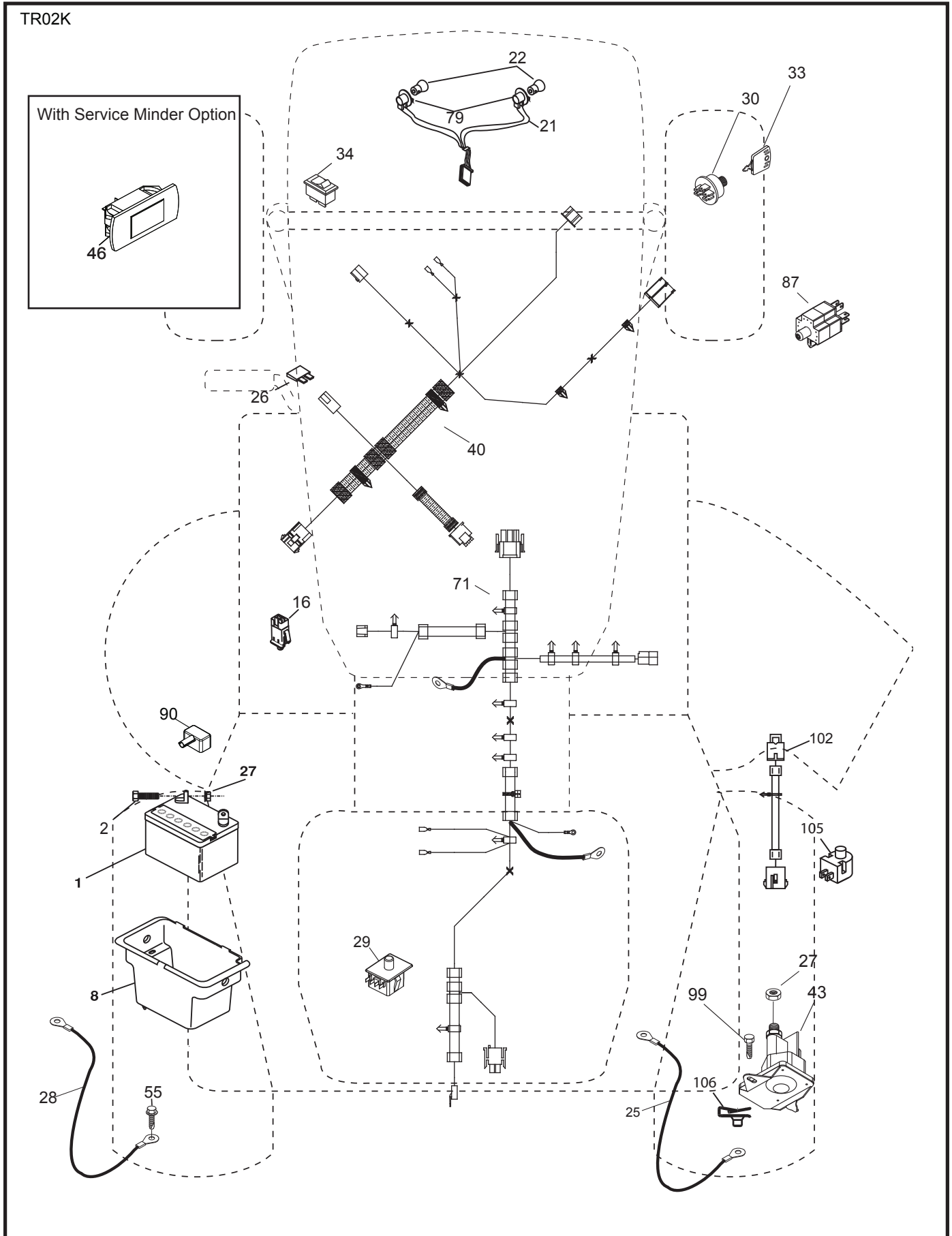

**TRACTOR - - MODEL NO. M185-117T (96041029601), PRODUCT NO. 960 41 02-96  
ELECTRICAL 32**

<b>KEY NO.</b>	<b>PART NO.</b>	<b>DESCRIPTION</b>
1	532 16 34-65	Battery
2	874 76 04-12	Bolt Hex Head 1/4-20 x 3/4
8	532 19 32-28	Box Battery
16	532 17 61-38	Switch Interlock Push-In
21	532 40 02-52	Harness Socket Light w/4152J
22	532 00 41-52	Bulb Light
25	581 49 80-01	Cable Starter
26	532 17 51-58	Fuse
27	873 51 04-00	Nut Keps Hex 1/4-20 unc
28	532 42 16-86	Cable,Ground
29	532 40 15-45	Switch, Seat
30	532 19 33-50	Switch, Ign
33	532 41 19-35	Key/Chain
34	532 11 07-12	Switch Light/Reset
40	581 02 31-01	Harness Ign. Dash
43	532 19 25-07	Solenoid
55	817 06 05-12	Screw Thdrol 5/16-18 x 3/4 TYTT
71	581 02 30-01	Harness Ign.
79	532 17 52-42	Socket Asm
87	532 19 78-02	Switch Interlock Clutch Cbl
90	532 43 53-95	Cover Terminal
99	817 67 04-12	Screw
102	532 40 44-54	Harness Pigtail
105	532 40 75-68	Switch Reverse
106	532 17 48-14	Pal Nut

**NOTE:** All component dimensions given in U.S. inches  
1 inch = 25.4 mm

TRACTOR -- MODEL NO. M185-117T (96041029601), PRODUCT NO. 960 41 02-96  
CHASSIS AND ENCLOSURES **39**

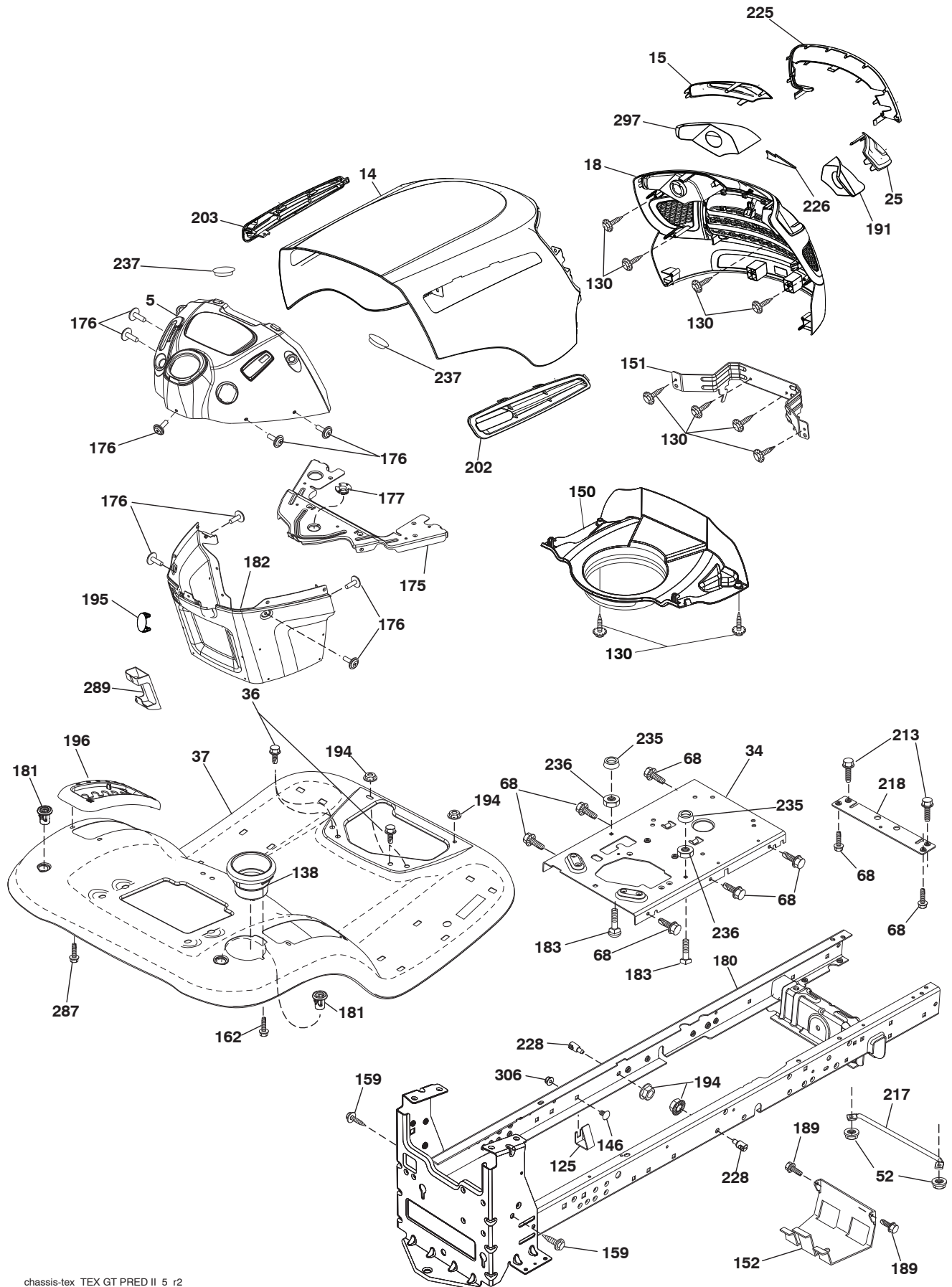

**TRACTOR - - MODEL NO. M185-117T (96041029601), PRODUCT NO. 960 41 02-96  
CHASSIS AND ENCLOSURES **39****

<b>KEY NO.</b>	<b>PART NO.</b>	<b>DESCRIPTION</b>
5	532 44 66-39	Dash
14	532 44 80-42	Hood
15	581 10 31-01	Lens LH
18	581 10 29-01	Grille
25	581 10 30-01	Lens RH
34	580 91 08-01	Plate Engine
36	817 06 05-12	Screw 5/16-18 x 3/4
37	532 42 07-96	Fender
52	873 68 05-00	Nut Crown Lock 5/16
68	817 49 05-08	Screw THDROL 5/16-18 x 1/2
125	581 68 48-01	Clip Fuel Line
130	532 41 63-58	Screw
138	532 40 97-30	Cupholder
146	581 85 79-01	Bolt
150	584 86 29-03	Air Duct
151	532 44 54-94	Bracket Pivot
152	532 19 95-35	Shield Browning
159	817 00 06-12	Screw 3/8-16 x 3/4
162	532 14 24-32	Screw 1/4 x 1/2
175	532 19 63-04	Crossmember
176	532 40 07-76	Screw 10-24 x 5/8
177	532 19 52-27	Bushing Steering
180	532 19 54-57	Chassis
181	532 40 47-96	Bushing Mtg. Fender Crgo
182	532 40 68-59	Dash Lower
183	874 52 05-20	Bolt 5/16-18 x 1-1/4
189	817 00 05-12	Screw 5/16-18 x 3/4
191	581 22 35-01	Reflector RH
194	873 90 05-00	Nut Lock Hex Flange 5/16-18
195	532 40 41-37	Plug Hole Dash Lower
196	532 41 45-81	Console Asm. Deck Lift
202	581 85 91-01	Side Vent RH
203	581 85 92-01	Side Vent LH
213	874 76 05-12	Bolt 5/16-18 x 3/4
217	532 40 91-67	Rod Pivot Hood
218	532 19 63-95	X-Piece Hood Stop
225	581 10 32-01	Trim Ring
226	578 89 71-01	Emblem
228	532 19 51-61	Stud Fastener
235	532 40 61-29	Spacer Fender
236	873 93 05-00	Nut Lock 5/16-18 unc
237	532 40 37-04	Plug Mount Cargo
287	817 60 04-06	Screw Hex Washhead 1/4-20 x 3/8
289	532 40 35-71	Plug Cruise/Phone
297	581 22 36-01	Reflector LH
306	873 90 06-00	Nut
--	532 44 11-26	Plug Dash SRVMNDR.
--	532 40 09-44	Bumper Kit

**NOTE:** All component dimensions given in U.S. inches  
1 inch = 25.4 mm

TRACTOR -- MODEL NO. M185-117T (96041029601), PRODUCT NO. 960 41 02-96  
 DRIVE **40**

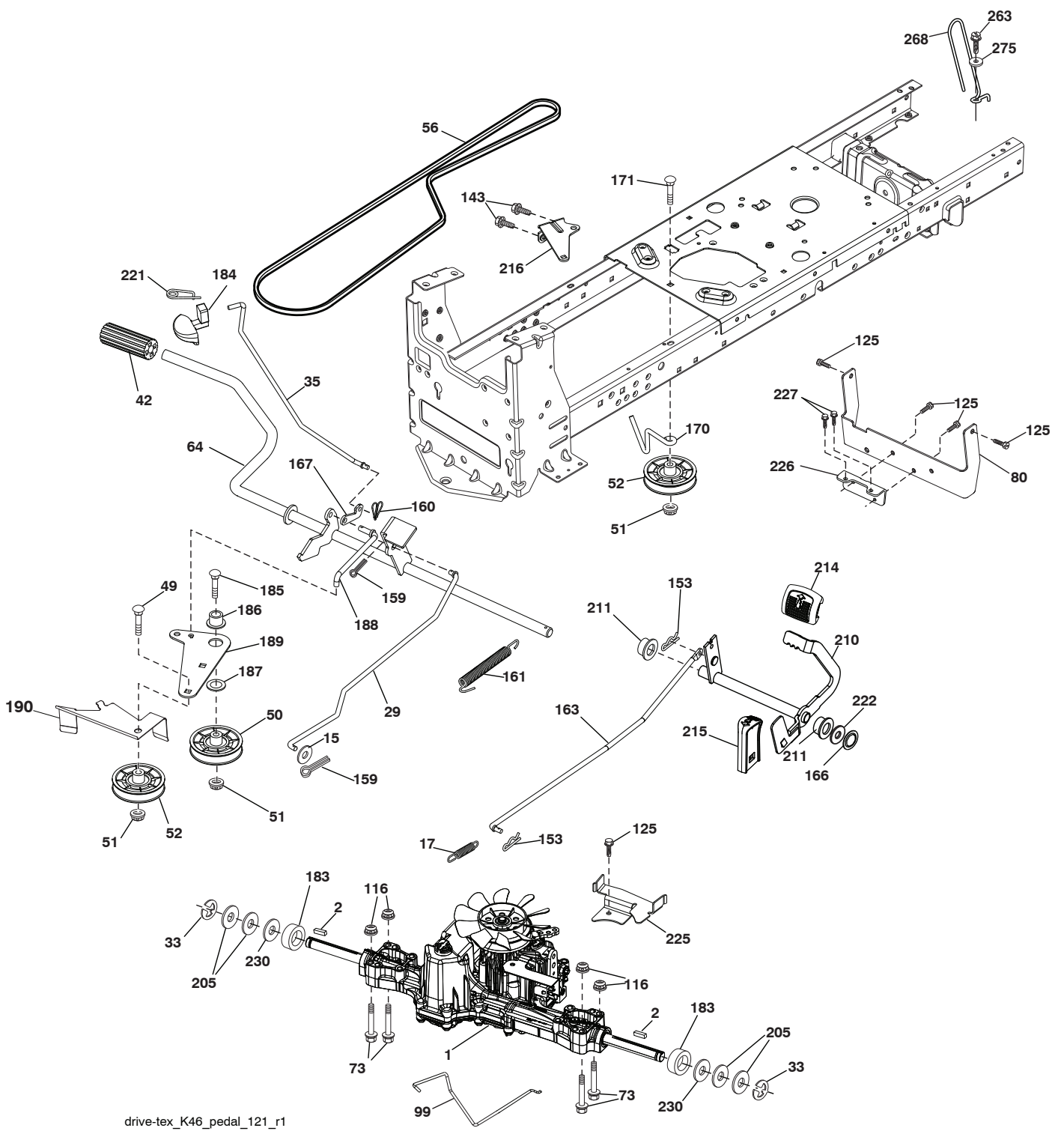

drive-tex\_K46\_pedal\_121\_r1



**TRACTOR - - MODEL NO. M185-117T (96041029601), PRODUCT NO. 960 41 02-96  
DRIVE 40**

KEY NO.	PART NO.	DESCRIPTION
1	---	Transaxle, TUFFTORQ K46 BT (426120) (Order parts from transaxle manufacturer.)
2	532 12 35-83	Key
15	819 13 13-16	Washer 13/32 x 13/16 x 16 Ga.
17	532 41 36-78	Spring, Brake
29	532 40 38-06	Rod, Brake
33	812 00 00-01	Ring E
35	583 86 45-01	Rod, Brake, Park
42	532 12 48-72	Cover, Foot Pedal
49	872 11 06-14	Bolt
50	532 19 43-27	Pulley Idler Flat
51	873 90 06-00	Lock Nut 3/8-16
52	532 19 43-26	Idler V-Groove 910" Offset
56	532 13 09-69	V-Belt, Drive
64	532 19 78-65	Shaft Asm. Pedal Brake Control
73	874 49 05-40	Bolt Hex Flghd 5/16-18 Gr. 5
80	532 44 06-19	Bracket Strap Torque
99	532 41 57-42	Rod Spring Bypass
116	873 90 05-00	Nut Lock Hex Flange 5/16-18
125	817 00 05-12	Screw 5/16-18 x 3/4
143	817 49 05-08	Screw 5/16-18 x 1/2
153	532 12 47-88	Retainer Spring
159	876 02 04-12	Pin Cotter 1/8 x 3/4
160	532 16 94-84	Retainer Clip
161	532 10 57-09	Spring, Return, Clutch
163	532 44 82-75	Rod Pedal Control
166	532 42 91-64	Nut Push
167	532 40 52-57	Latch Brake Parking
170	532 19 43-22	Keeper Belt Centerspan
171	872 11 06-16	Bolt RDHD SQNK 3/8-16 unc x 2
183	532 13 70-57	Spacer Split
184	532 44 14-55	Handle Parking Brake
185	872 11 06-22	Bolt RDHD 3/8-16 unc x 2-3/4 Gr. 5
186	532 19 43-21	Spacer Retainer
187	819 13 32-10	Washer
188	532 19 43-23	Link Clutch Ground Drive
189	532 19 43-17	Bellcrank Ground Drive
190	532 19 43-18	Keeper Bellcrank Ground Drive
205	532 12 17-48	Washer
210	532 40 09-80	Rocker Asm. Pedal Control
211	532 12 01-83	Bearing Nylon
214	532 42 12-63	Pedal Forward
215	532 40 17-23	Pedal Reverse
216	532 19 61-31	Bracket Pulley Idler
221	532 40 31-87	Retainer Spring Clip Handle
222	879 21 20-10	Washer 21/32 x 1-1/4 x 10 Ga.
225	532 40 33-19	Keeper Belt Trans.
226	532 40 15-64	Bracket Mount Torque
227	817 49 05-12	Screw Thdrol 5/16-18 x 3/4
230	532 18 89-67	Washer Hardened
263	817 00 06-12	Screw Hexwsh Thdr 3/8-16 x 3/4
268	532 18 24-02	Guard Muffler RH
275	819 13 16-14	Washer 13/32 x 1 x 14 Ga.

**NOTE:** All component dimensions given in U.S. inches  
1 inch = 25.4 mm

TRACTOR - - MODEL NO. M185-117T (96041029601), PRODUCT NO. 960 41 02-96  
ENGINE **24**

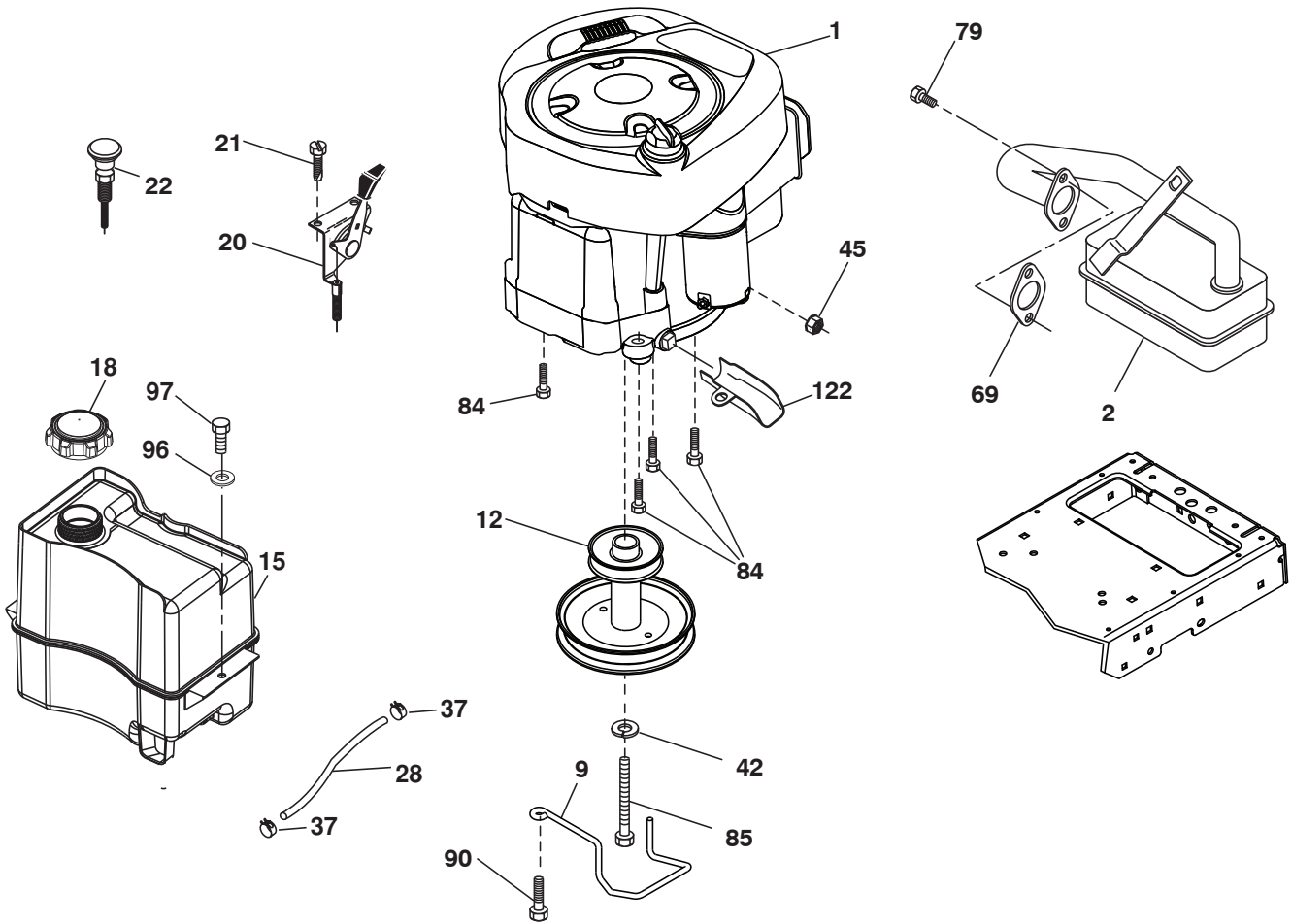

29

**OPTIONAL EQUIPMENT**

**Spark Arrester**

engine-tex\_BS\_78

**TRACTOR - - MODEL NO. M185-117T (96041029601), PRODUCT NO. 960 41 02-96  
ENGINE 24**

KEY NO.	PART NO.	DESCRIPTION
1	- - - - -	Engine Briggs Model No. 31N707-2441-B1 (438156) (Order parts from engine manufacturer.)
2	532 13 73-52	Muffler
9	532 19 43-20	Keeper Belt Engine
12	532 40 54-72	Pulley Engine
15	532 43 08-25	Tank Fuel
18	532 43 02-20	Cap Asm
20	532 40 15-08	Control Throttle
21	532 41 63-58	Screw #10 x 0.750 BOS Thread
22	532 19 49-81	Control Choke
28	532 13 70-40	Fuel Line
29	532 13 71-80	Spark Arrester Kit
37	532 12 34-87	Clamp Hose
42	810 04 07-00	Washer Lock 7/16
45	873 51 04-00	Nut Keps Hex 1/4-20 unc
69	532 16 52-91	Gasket
79	532 19 23-34	Screw 5/16-18 x .75
84	817 06 06-20	Screw 3/8-16 x 1-1/4
85	532 17 39-37	Bolt 7/16-20 x 4
90	817 00 06-16	Screw 3/8-16 x 1
96	819 09 14-16	Washer 9/32 x 7/8 x 16 Ga.
97	817 67 04-12	Screw 1/4 - 20 x 3/4
122	532 42 19-22	Extension Drain Oil

**NOTE:** All component dimensions given in U.S. inches  
1 inch = 25.4 mm

**Engine Power Rating Information**

The gross power rating for individual gas engine models is labeled in accordance with SAE (Society of Automotive Engineers) code J1940 (Small Engine Power & Torque Rating Procedure), and rating performance has been obtained and corrected in accordance with SAE J1995 (Revision 2002-05). Torque values are derived at 3060 RPM; horsepower values are derived at 3600 RPM. Actual gross engine power will be lower and is affected by, among other things, ambient operating conditions and engine-to-engine variability. Given both the wide array of products on which engines are placed and the variety of environmental issues applicable to operating the equipment, the gas engine will not develop the rated gross power when used in a given piece of power equipment (actual "on-site" or net power). This difference is due to a variety of factors including, but not limited to, accessories (air cleaner, exhaust, charging, cooling, carburetor, fuel pump, etc.), application limitations, ambient operating conditions (temperature, humidity, altitude), and engine-to-engine variability. Due to manufacturing and capacity limitations, Briggs & Stratton may substitute an engine of higher rated power for this Series engine.

TRACTOR -- MODEL NO. M185-117T (96041029601), PRODUCT NO. 960 41 02-96  
STEERING ASSEMBLY **41**

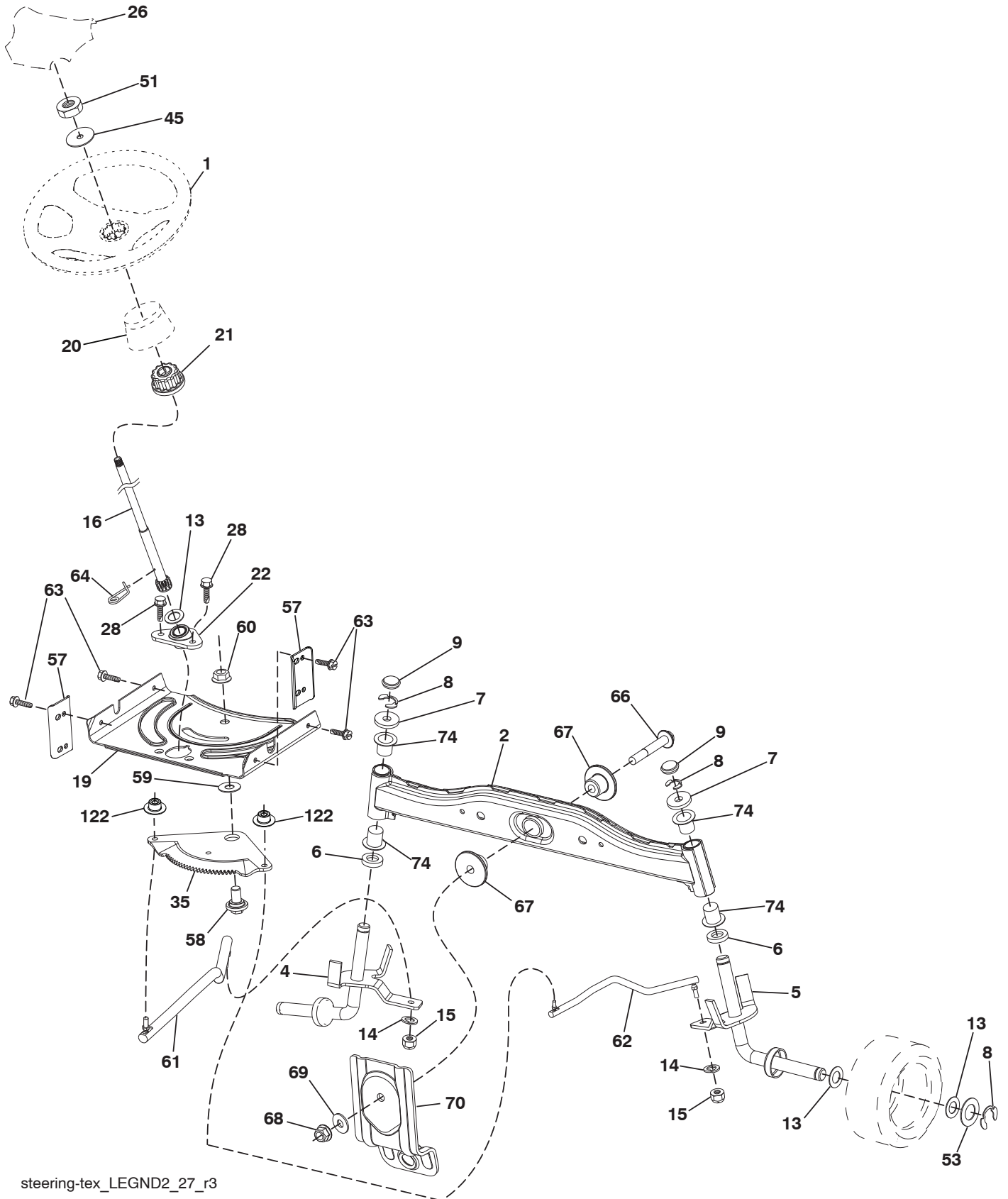

steering-tex\_LEGND2\_27\_r3

**TRACTOR - - MODEL NO. M185-117T (96041029601), PRODUCT NO. 960 41 02-96  
STEERING ASSEMBLY 41**

<b>KEY NO.</b>	<b>PART NO.</b>	<b>DESCRIPTION</b>
1	532 44 28-04	Wheel, Steering
2	532 41 81-68	Axle Asm., Front
4	532 40 30-87	Spindle Asm., LH
5	532 40 30-88	Spindle Asm., RH
6	532 12 49-31	Bearing, Race Thrust Harden
7	532 12 17-48	Washer 25/32 x 1-5/8 x 16 Ga.
8	812 00 00-29	Ring, Clip #T5304-75
9	532 12 12-32	Cap, Spindle
13	532 12 17-49	Washer 25/32 x 1-1/4 x 16 Ga.
14	810 04 06-00	Washer, Lock Hvy Hlcl Spr 3/8
15	873 54 06-00	Nut, Crown Lock 3/8-24 unf
16	532 19 47-46	Shaft Steering
19	532 19 47-29	Plate Steering
20	532 42 47-40	Boot Steering
21	532 18 67-37	Adapter, Wheel Steering
22	532 42 05-37	Steering Support Lower
26	532 44 77-59	Insert, Wheel Steering
28	817 00 06-12	Screw 3/8-16 x 3/4
35	532 19 47-32	Gear, Sector Plate
45	819 18 38-12	Washer 9/16 x 2-3/8 12 Ga.
51	873 94 08-00	Nut Hex Jam Toplock 1/2-20 unf
53	532 18 89-67	Washer Hardened .793 x 1.637 x .060
57	532 40 74-65	Bracket Upstop
58	532 19 47-47	Bolt Shoulder Sector Pivot CFM
59	532 19 47-48	Washer Thrust Sector Steering
60	873 97 10-00	Nut Flange Lock 5/8-11
61	532 19 47-40	Draglink LH
62	532 19 47-41	Draglink, RH
63	817 00 05-12	Screw 5/16-18 x 3/4
64	532 19 98-49	Retainer Clip Spring Steering
66	871 02 07-48	Bolt Hex Fghd 7/16-14 x 3 Serr
67	532 19 47-37	Bushing PM Front Axle
68	873 90 07-00	Nut Lock Flange 7/16-14 Gr. 5
69	532 19 91-62	Washer 1.5 x .505 x .118
70	532 19 61-97	Bracket Deck Susp. Front
74	532 12 49-37	Bearing
122	532 44 49-62	Cap Gear Sector

**NOTE:** All component dimensions given in U.S. inches  
1 inch = 25.4 mm

**TRACTOR -- MODEL NO. M185-117T (96041029601), PRODUCT NO. 960 41 02-96**  
**MOWER DECK 44**

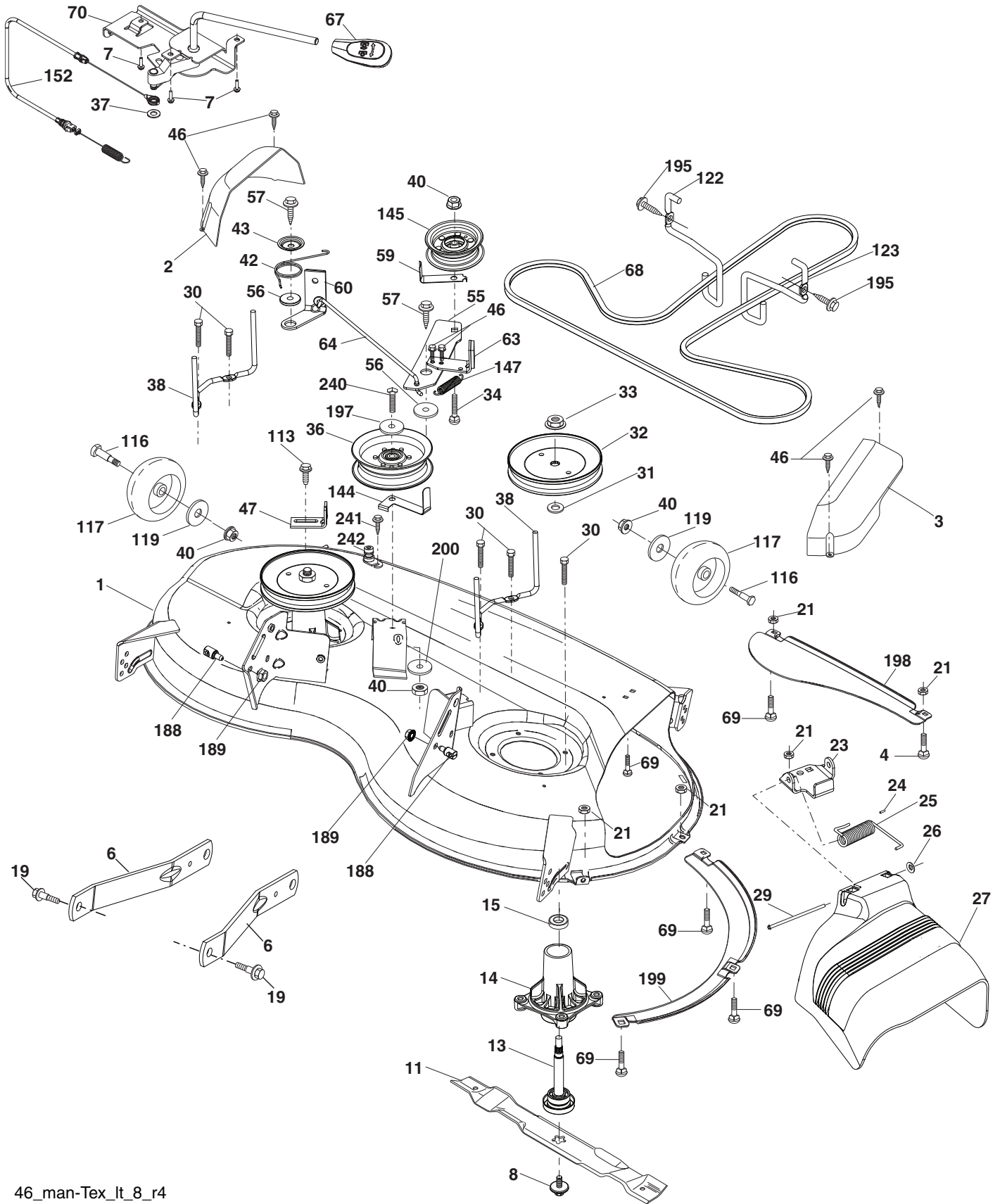

46\_man-Tex\_lt\_8\_r4

**TRACTOR - - MODEL NO. M185-117T (96041029601), PRODUCT NO. 960 41 02-96  
MOWER DECK 44**

KEY NO.	PART NO.	DESCRIPTION	KEY NO.	PART NO.	DESCRIPTION
1	532 44 81-36	Mower Housing	63	532 19 94-77	Arm Brake Mower
2	532 40 55-07	Cover Mandrel LH	64	532 40 51-38	Linkage Brake
3	532 40 55-06	Cover Mandrel RH	67	532 40 30-12	Handle Clutch Cable
4	874 76 05-12	Bolt Hex HD 5/16-18	68	532 40 51-43	Belt, Drive
6	532 19 51-86	Arm Suspension	69	872 14 05-05	Bolt
7	532 41 63-58	Screw #10	70	532 19 99-72	Clutch Asm
8	532 19 30-03	Bolt/Washer Asm 7/16-20 unf	113	817 00 05-10	Bolt 5/16-18
11	532 40 53-80	Blade	116	532 19 34-06	Bolt, Shoulder
13	532 19 28-72	Shaft Assembly, Mandrel	117	532 17 48-73	Wheel, Gauge
14	532 18 72-81	Housing, Mandrel	119	819 13 20-12	Washer 13/32 x 1-1/4 x 12 Ga.
15	532 11 04-85	Bearing, Ball, Mandrel	122	532 19 72-58	Keeper Belt LH
19	532 19 65-39	Bolt, Shoulder	123	532 19 72-59	Keeper Belt RH
21	873 68 05-00	Nut, Crownlock 5/16-18 unc	144	532 19 92-04	Keeper Belt
23	532 19 25-57	Bracket, Deflector	145	532 19 31-97	Pulley, Idler, Primary
24	532 10 53-04	Cap, Sleeve	147	532 40 18-72	Spring Return
25	532 19 70-26	Spring, Torsion, Deflector	152	584 24 35-01	Cable Clutch
26	532 11 04-52	Nut, Push	188	532 19 51-61	Stud Fastener
27	532 40 53-57	Shield, Deflector	189	873 90 05-00	Nut Lock Hex Flange
29	532 13 14-91	Rod, Hinge	195	817 00 06-12	Screw
30	532 17 39-84	Screw Thdrol Rolling Wsh Hd	197	819 13 13-12	Washer 13/32 x 13/16 x 12 Ga.
31	532 18 76-90	Washer, Spacer	198	532 40 31-49	Baffle Center Front
32	532 19 74-73	Pulley, Mandrel	199	532 40 31-50	Baffle Front RH
33	532 40 02-34	Nut, Toplock, Flanged	200	532 41 35-24	Washer 13/32 x 1 x 1/2 x 11 Ga.
34	872 11 06-12	Bolt Carr Sh. 3/8-16 x 1-1/2 Gr. 5	240	874 52 06-36	Bolt Fin Hex 3/8-16 x 2-1/4 Gr. 5
36	532 19 73-79	Pulley Idler	241	532 15 29-27	Screw #10-32.5 3/8 Flange
37	819 13 13-16	Washer 13/32 x 13/16 x 16	242	532 41 55-98	Port Washout
38	532 43 25-20	Keeper Belt Mandrel	--	532 19 28-70	Mandrel Assembly (Includes Housing (key #14), Shaft Assembly (key #13) and Bearing Only (key #15) -pulley/Nut/Washer and Blade Bolt/Washer not Included)
40	873 90 06-00	Nut, Lock Flg. 3/8-16 unc	--	532 43 45-90	Replacement Mower, Complete
42	532 19 84-10	Spring Torsion Brake			
43	532 19 72-56	Spring Torsion Retainer			
46	532 13 77-29	Screw 1/4-20 x 5/8			
47	532 19 72-50	Bracket Clutch Cable			
55	532 19 72-49	Arm, Idler			
56	532 19 90-92	Spacer, Retainer			
57	817 00 06-16	Screw 3/8-16 x 1			
59	532 14 10-43	Guard, Tuv Idler			
60	532 19 94-71	Arm Brake Mower			

**NOTE:** All component dimensions given in U.S. inches  
1 inch = 25.4 mm



**TRACTOR - - MODEL NO. M185-117T (96041029601), PRODUCT NO. 960 41 02-96**  
**MOWER LIFT 45**

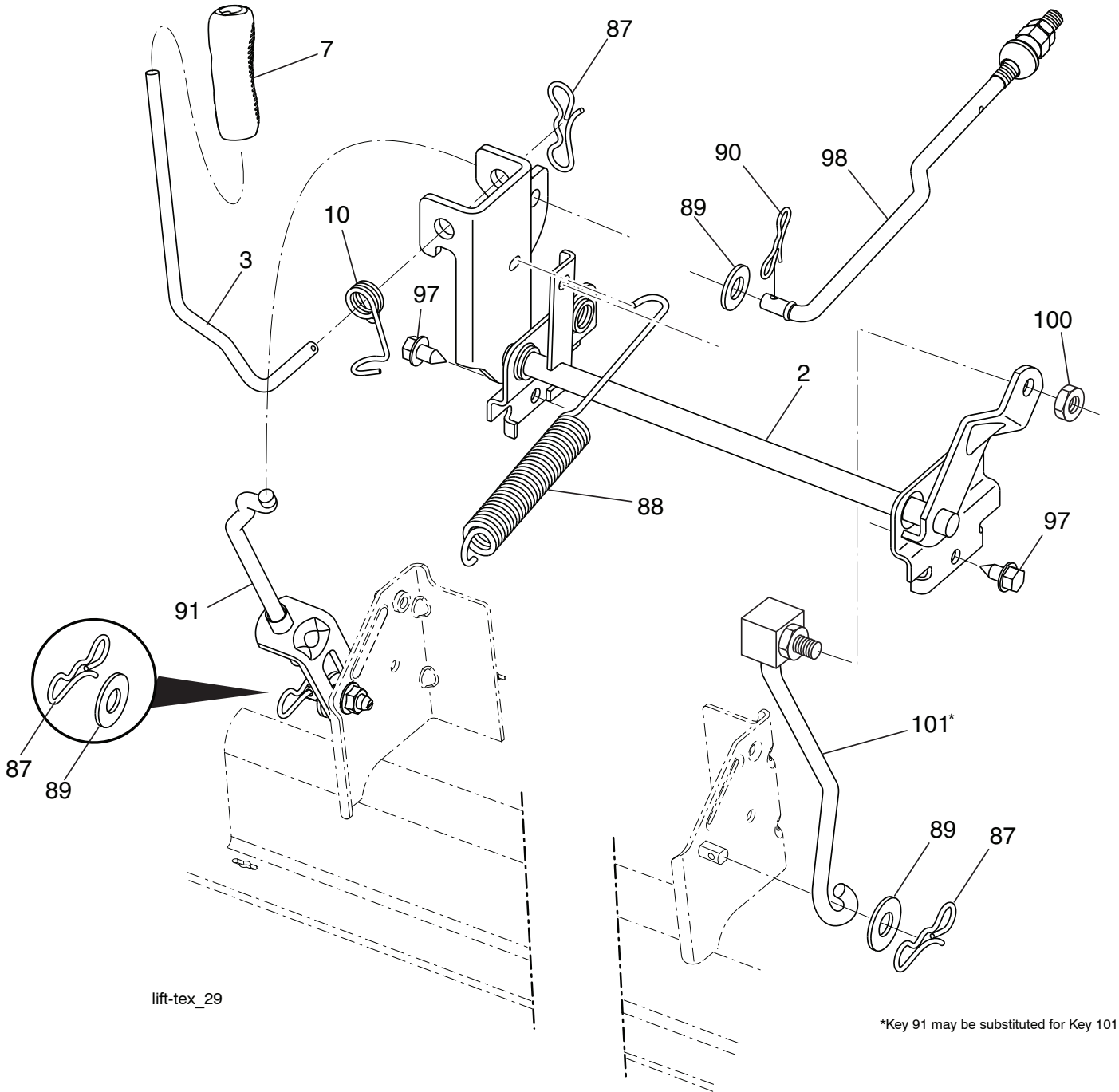

KEY NO.	PART NO.	DESCRIPTION
2	532 42 20-27	Shaft Asm., Lift
3	532 19 52-31	Lever Asm., Lift RH
7	580 96 23-01	Grip, Lever
10	532 19 63-14	Spring Torsion
87	532 19 42-09	Pin Cotter 7/16 Bow Tie Lock
88	532 41 07-10	Spring Lift Assist
89	819 19 19-12	Washer 17/32 x 1-3/16 x 12 Ga.
90	532 19 42-08	Pin Cotter 5/16 Bow Tie Lock

KEY NO.	PART NO.	DESCRIPTION
91	532 19 51-81	Link Lift Susp Mower Rear
97	817 00 06-12	Screw 3/8-16 x .75
98	532 19 52-70	Link Lift Susp. Front Mower
100	873 93 06-00	Nut Center Lock 3/8-16 unc
101	532 40 70-03	Link Asm. Lift

**NOTE:** All component dimensions given in U.S. inches  
 1 inch = 25.4 mm



**TRACTOR - - MODEL NO. M185-117T (96041029601), PRODUCT NO. 960 41 02-96  
SEAT ASSEMBLY 42**

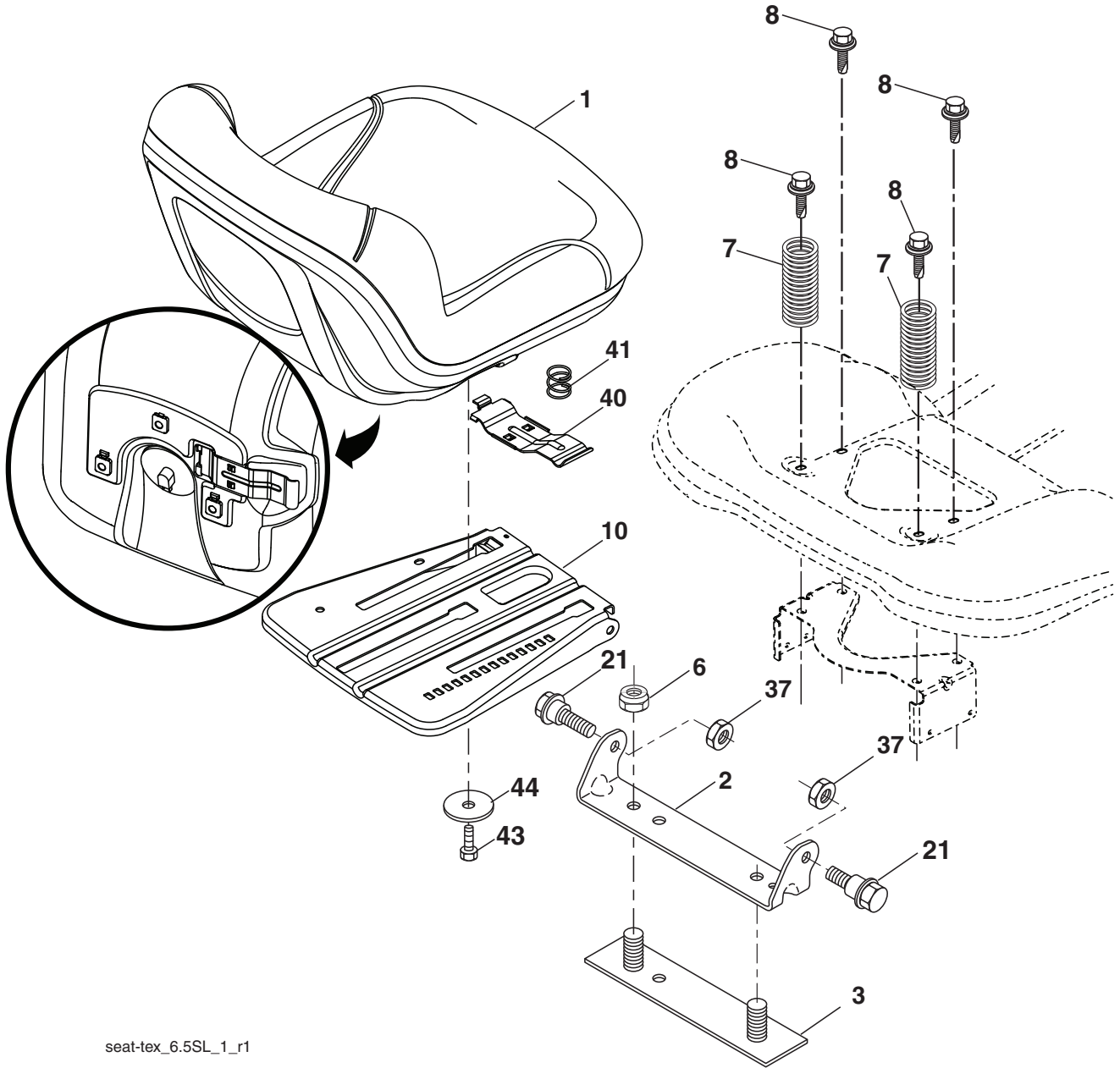

seat-tex\_6.5SL\_1\_r1

KEY NO.	PART NO.	DESCRIPTION
1	581 46 22-01	Seat
2	532 18 01-66	Bracket Pivot Fender
3	532 14 06-75	Strap, Asm Fender
6	873 80 06-00	Nut, Lock w/Ins. 3/8-16 unc
7	532 12 41-81	Spring, Seat Cprsn
8	532 17 18-77	Bolt 5/16-18 unc x 3/4 w/Sems
10	532 19 69-77	Pan, Seat
21	532 17 18-52	Bolt, Shoulder 5/16-18

KEY NO.	PART NO.	DESCRIPTION
37	873 80 05-00	Nut, Lock 5/16-18 unc
40	532 19 76-61	Handle Slide Seat
41	532 19 82-00	Spring Latch Seat
43	874 76 06-12	Bolt 3/8-16 x 3/4
44	819 13 38-12	Washer 13/32 x 2-3/8 x 12 Ga.

**NOTE:** All component dimensions given in U.S. inches  
1 inch = 25.4 mm

