

ILLUSTRATED PARTS LIST

MODEL NO. 96041029701

CUSTOMER CATALOG NO. M185-117T

PRODUCT NO. 960 41 02-97

**TRACTOR -- MODEL NO. M185-117T (96041029701), PRODUCT NO. 960 41 02-97
DECALS 27**

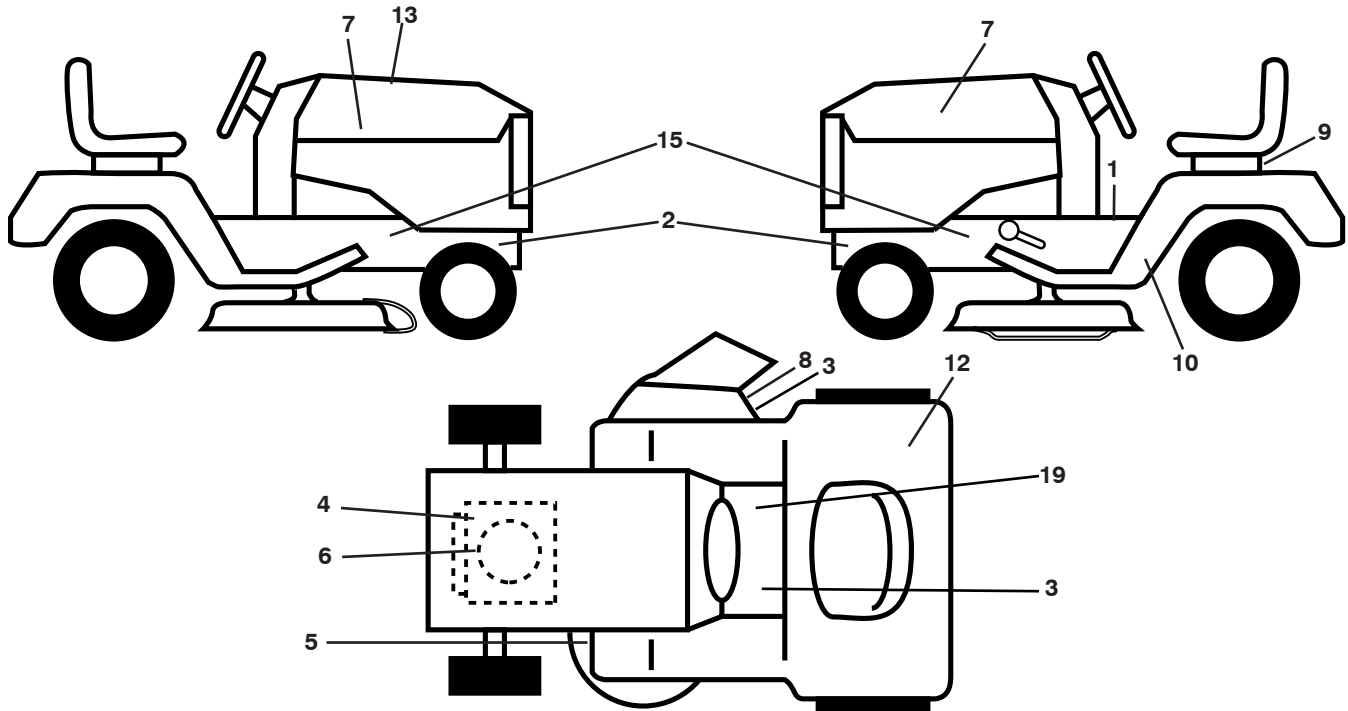

KEY NO.	PART NO.	DESCRIPTION
1	581 57 81-01	Decal, Warning Sym.
2	581 57 98-01	Decal, Warning Service/Fire
3	581 57 92-01	Decal, Warning
4	581 57 97-01	Decal, Warning Engine
5	581 58 00-01	Decal, V-Belt Sch.
6	532 43 74-20	Decal, Eng. HP
7	581 09 12-01	Decal, Hood LH/RH
8	581 57 91-01	Decal, Cutfinger
9	532 14 50-05	Decal, Battery Dnge/Poi
10	581 53 32-01	Decal, Fender Side

KEY NO.	PART NO.	DESCRIPTION
12	581 72 41-01	Decal, Fender DB/CE
13	584 22 05-01	Decal, Replacement
15	581 57 96-01	Decal, Hot Muffler
19	581 57 80-01	Decal, Saddle Brake Parking
--	581 72 48-01	Decal, Bypass
--	581 72 46-01	Decal, Load Limit
--	532 40 95-05	Pad, Footrest, LH
--	532 40 95-07	Pad, Footrest, RH
--	115 57 41-20	Manual, Oper Euro

WHEELS AND TIRES

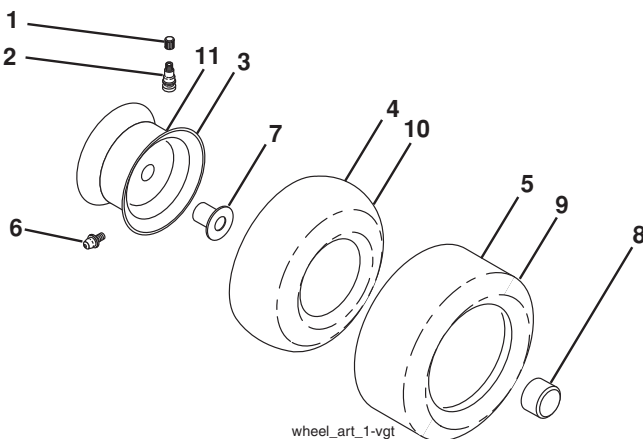

KEY NO.	PART NO.	DESCRIPTION
1	532 05 91-92	Cap, Valve, Tire
2	532 06 51-39	Stem, Valve
3	532 12 51-21	Rim Assembly, Front
4	532 05 99-04	Tube, Front (Service Item Only)
5	532 10 62-22	Tire, Front
6	532 12 49-57	Fitting, Grease (Front Wheel Only)
7	532 12 49-59	Bearing, Flange (Front Wheel Only)
8	532 19 32-68	Cap, Axle
9	532 13 84-68	Tire, Rear
10	532 12 49-26	Tube, Rear (Service Item Only)
11	532 12 51-22	Rim Assembly, Rear
--	532 14 43-34	Sealant, Tire (10 oz. Tube)

NOTE: All component dimensions given in U.S. inches
1 inch = 25.4 mm

TRACTOR - - MODEL NO. M185-117T (96041029701), PRODUCT NO. 960 41 02-97

SCHEMATIC **38**

SCH13

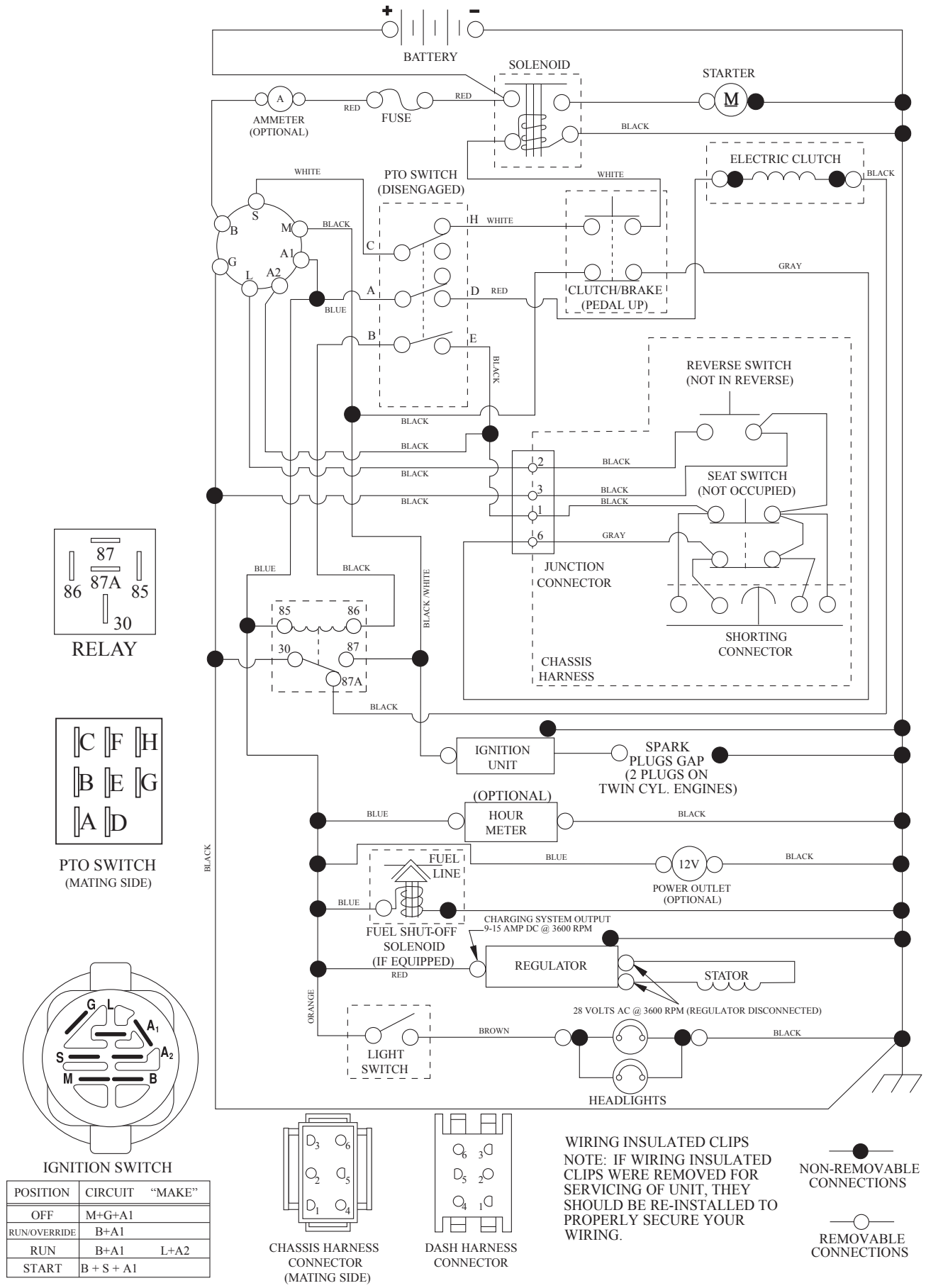

TRACTOR - - MODEL NO. M185-117T (96041029701), PRODUCT NO. 960 41 02-97
ELECTRICAL 32

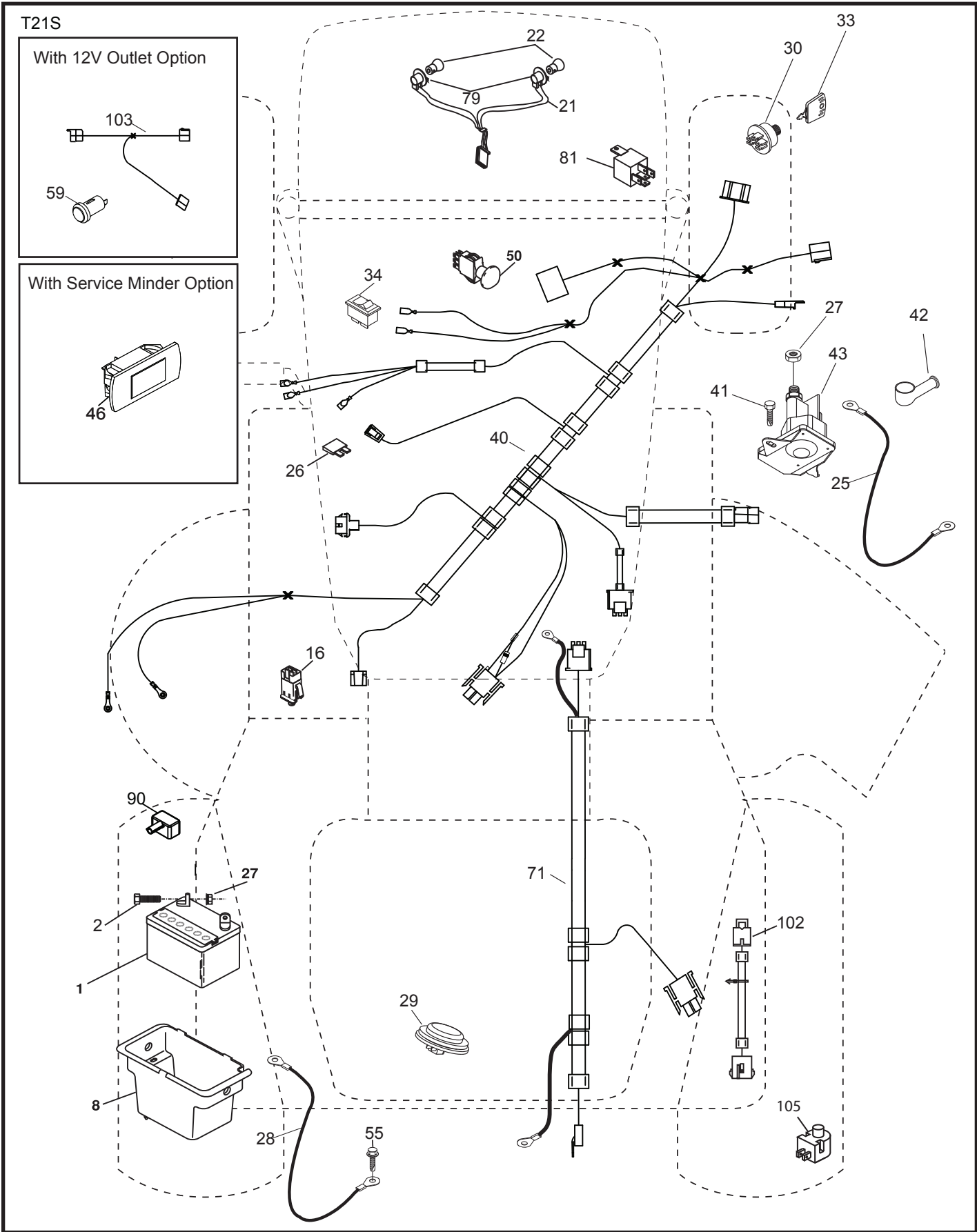

**TRACTOR - - MODEL NO. M185-117T (96041029701), PRODUCT NO. 960 41 02-97
ELECTRICAL 32**

KEY NO.	PART NO.	DESCRIPTION
1	532 16 34-65	Battery
2	874 76 04-12	Bolt Hex Hd 1/4-20 unc x 3/4
8	532 19 32-28	Battery Box
16	532 17 61-38	Switch Interlock
21	532 40 02-52	Harness Socket Light
22	532 00 41-52	Bulb, Light # 1156
25	585 55 55-01	Cable Starter
26	532 17 51-58	Fuse
27	873 51 04-00	Nut Keps Hex 1/4-20 unc
28	532 19 88-85	Cable Ground
29	532 40 15-45	Switch Seat
30	532 19 33-50	Switch Ign
33	532 41 19-35	Key/Chain
34	532 11 07-12	Switch Light/Reset
40	532 40 96-14	Harness Ign. Dash/Lift
41	817 72 04-08	Screw Thd Cut 1/4-20 x 1/2
42	532 13 15-63	Cover Terminal Red
43	532 19 25-07	Solenoid
50	532 17 46-51	Switch PTO
55	817 06 05-12	Screw Thdrol 5/16-18 x 3/4
71	532 44 15-44	Harness Ign. Chassis/Lift
79	532 17 52-42	Socket Asm. Bulb
81	532 40 96-15	Relay Harness
90	532 43 53-95	Cover Terminal Battery
102	532 40 44-54	Harness Pigtail
105	532 40 75-68	Switch Reverse

NOTE: All component dimensions given in U.S. inches
1 inch = 25.4 mm

TRACTOR - - MODEL NO. M185-117T (96041029701), PRODUCT NO. 960 41 02-97
CHASSIS AND ENCLOSURES **39**

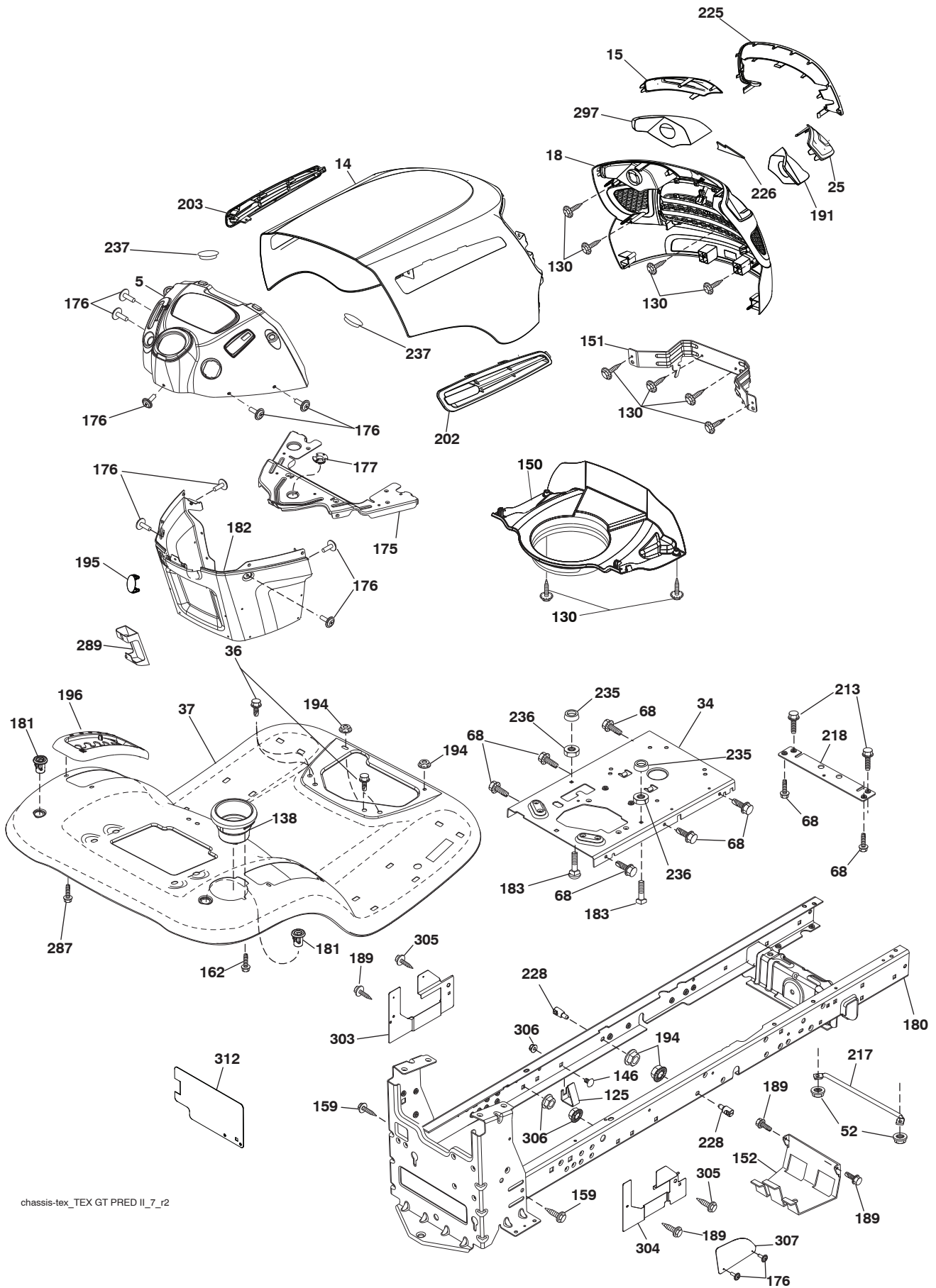

chassis-tex_TEX GT PRED II_7_r2

**TRACTOR - - MODEL NO. M185-117T (96041029701), PRODUCT NO. 960 41 02-97
CHASSIS AND ENCLOSURES 39**

KEY NO.	PART NO.	DESCRIPTION	KEY NO.	PART NO.	DESCRIPTION
5	532 42 47-38	Dash	196	532 41 45-81	Console Asm. Deck Lift
14	532 44 80-42	Hood	202	581 85 91-01	Side Vent RH
15	581 10 31-01	Lens LH	203	581 85 92-01	Side Vent LH
18	581 10 29-01	Grille	213	874 76 05-12	Bolt 5/16-18 x 3/4
25	581 10 30-01	Lens RH	217	532 40 91-67	Rod Pivot Hood
34	580 91 08-01	Plate Engine	218	532 19 63-95	X-Piece Hood Stop
36	817 06 05-12	Screw 5/16-18 x 3/4	225	581 10 32-01	Trim Ring
37	532 42 07-96	Fender	226	578 89 71-01	Emblem
52	873 68 05-00	Nut Crown Lock 5/16	228	532 19 51-61	Stud Fastener
68	817 49 05-08	Screw THDROL 5/16-18 x 1/2	235	532 40 61-29	Spacer Fender
125	581 68 48-01	Clip Fuel Line	236	873 93 05-00	Nut Lock 5/16-18 unc
130	532 41 63-58	Screw	237	532 40 37-04	Plug Mount Cargo
138	532 40 97-30	Cupholder	287	817 60 04-06	Screw Hex Washhead 1/4-20 x 3/8
146	581 85 79-01	Bolt	289	532 40 35-71	Plug Cruise/Phone
150	584 86 29-03	Air Duct	297	581 22 36-01	Reflector LH
151	532 44 54-94	Bracket Pivot	303	532 42 09-59	Shield Chassis French LH
152	532 19 95-35	Shield Browning	304	532 42 15-09	Shield Chassis French RH
159	817 00 06-12	Screw 3/8-16 x 3/4	305	872 11 06-06	Bolt RDHD SHT SQNK 3/8-16 x 3/4
162	532 14 24-32	Screw 1/4 x 1/2	306	873 90 06-00	Nut Lock Fig. 3/8-16 unc
175	532 19 63-04	Crossmember	307	532 42 45-70	Shield Upper Pedal
176	532 40 07-76	Screw 10-24 x 5/8	312	532 42 59-26	Shield Drawbar
177	532 19 52-27	Bushing Steering	--	532 41 17-08	Plug Dash SRVMNDR.
180	532 19 54-57	Chassis	--	532 40 09-44	Bumper Kit
181	532 40 47-96	Bushing Mtg. Fender Crgo			
182	532 40 68-59	Dash Lower			
183	874 52 05-20	Bolt 5/16-18 x 1-1/4			
189	817 00 05-12	Screw 5/16-18 x 3/4			
191	581 22 35-01	Reflector RH			
194	873 90 05-00	Nut Lock Hex Flange 5/16-18			
195	532 40 41-37	Plug Hole Dash Lower			

NOTE: All component dimensions given in U.S. inches
1 inch = 25.4 mm

**TRACTOR -- MODEL NO. M185-117T (96041029701), PRODUCT NO. 960 41 02-97
DRIVE **40****

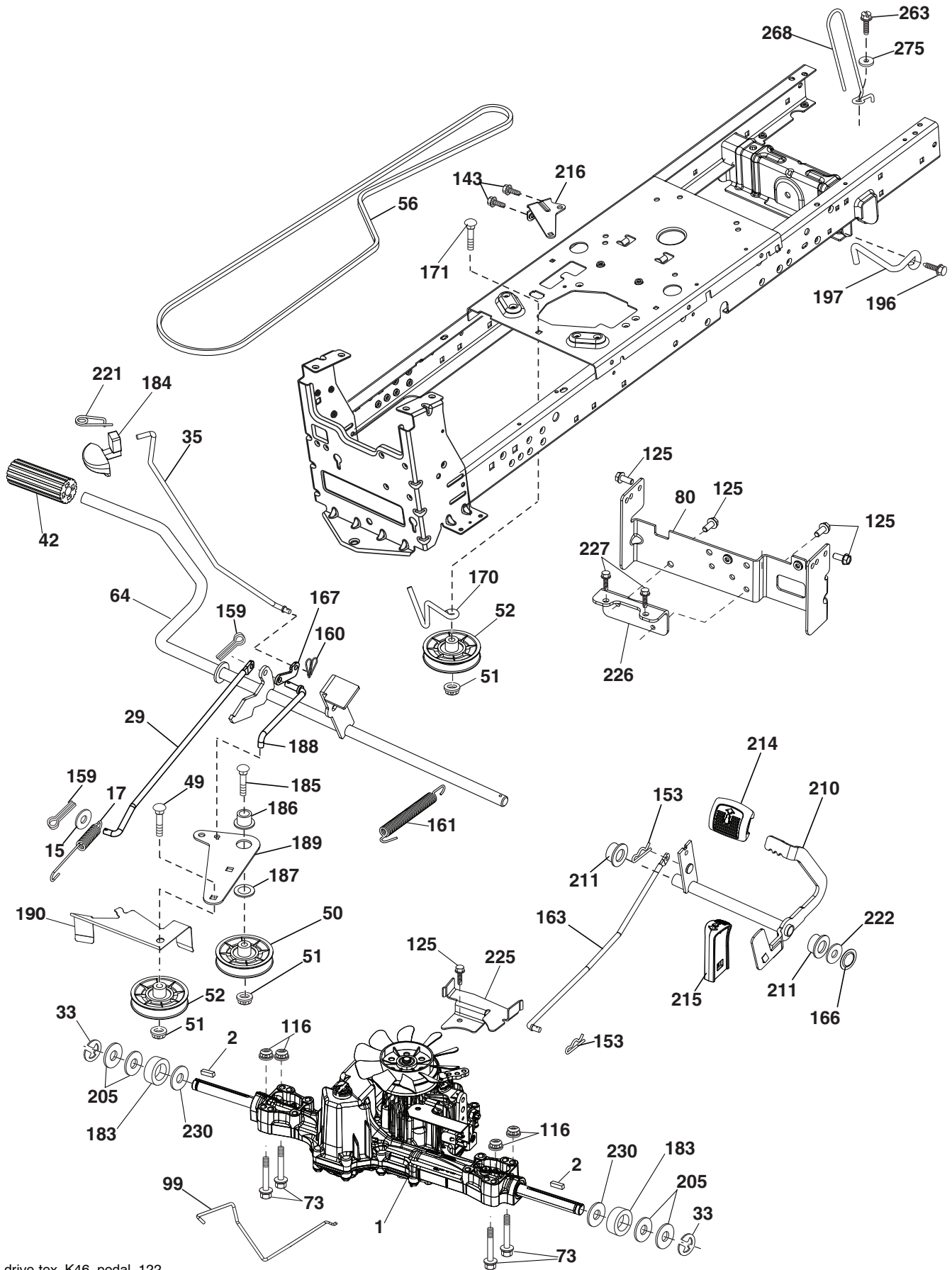

**TRACTOR - - MODEL NO. M185-117T (96041029701), PRODUCT NO. 960 41 02-97
DRIVE 40**

KEY NO.	PART NO.	DESCRIPTION	KEY NO.	PART NO.	DESCRIPTION
1	-----	Transaxle, TUFFTORQ K46 BT (426120) (Order parts from trans- axle manufacturer.)	183	532 13 70-57	Spacer Split
2	532 12 35-83	Key	184	532 44 14-55	Handle Parking Brake
15	819 13 13-16	Washer 13/32 x 13/16 x 16 Ga.	185	872 11 06-22	Bolt Rdhd Sqnk 3/8-16 x 2-3/4 Gr. 5
17	532 41 36-78	Spring Brake	186	532 19 43-21	Spacer Retainer
29	532 40 38-06	Rod, Brake	187	819 13 32-10	Washer
33	812 00 00-01	Ring E	188	532 19 43-23	Link Clutch Ground Drive
35	583 86 45-01	Rod Brake Park	189	532 19 43-17	Bellcrank Ground Drive
42	532 12 48-72	Cover Foot Pedal	190	532 19 43-18	Keeper Bellcrank Ground Drive
49	872 11 06-14	Bolt	196	817 00 06-16	Screw 3/8-16 x 1
50	532 19 43-27	Pulley Idler Flat	197	585 65 86-01	Link Clutch Anti-Rotation
51	873 90 06-00	Lock Nut 3/8-16	205	532 12 17-48	Washer
52	532 19 43-26	Idler V-Groove	210	532 40 09-80	Rocker Ams Pedal Control
56	532 13 09-69	V-Belt Drive	211	532 12 01-83	Bushing Brake Shaft
64	532 19 78-65	Shaft Asm. Pedal Brake Control	214	532 42 12-63	Pedal Forward Pad Tex
73	874 49 05-40	Bolt Hex Flghd 5/16-18 X 2 1/2 Gr. 5	215	532 40 17-23	Pedal Reverse Tex GT
80	532 44 06-19	Strap Torque	216	532 19 61-31	Bracket Pulley Idler
99	532 41 57-42	Rod Bypass Spring	221	532 40 31-87	Retainer Spring Clip Handle
116	873 90 05-00	Nut Lock Hex Flange 5/16-18	222	879 21 20-10	Washer 21/32 x 1-1/4
125	817 00 05-12	Screw 5/16-18 x 3/4	225	532 40 33-19	Keeper Belt Trans.
143	817 49 05-08	Screw 5/16-18 x 1/2	226	532 40 15-64	Bracket Mount Torque
153	532 12 47-88	Retainer Spring	227	817 49 05-12	Screw Thdrol 5/16-18 x 3/4
159	876 02 04-12	Pin Cotter 1/8 x 3/4	230	532 18 89-67	Washer Hardened
160	532 16 94-84	Retainer Clip	263	817 00 06-12	Screw
161	532 10 57-09	Spring Return Clutch	268	532 18 24-02	Guard.Muffler
163	532 44 82-75	Rod Control Pedal K46	275	819 13 16-14	Washer 13/32 x 1 x 14
166	532 42 91-64	Nut Push			
167	532 40 52-57	Latch Brake Parking			
170	532 19 43-22	Keeper Belt Centerspan			
171	872 11 06-16	Bolt RDHD SQNK 3/8-16 unc x 2			

NOTE: All component dimensions given in U.S. inches
1 inch = 25.4 mm

TRACTOR - - MODEL NO. M185-117T (96041029701), PRODUCT NO. 960 41 02-97
 ENGINE **24**

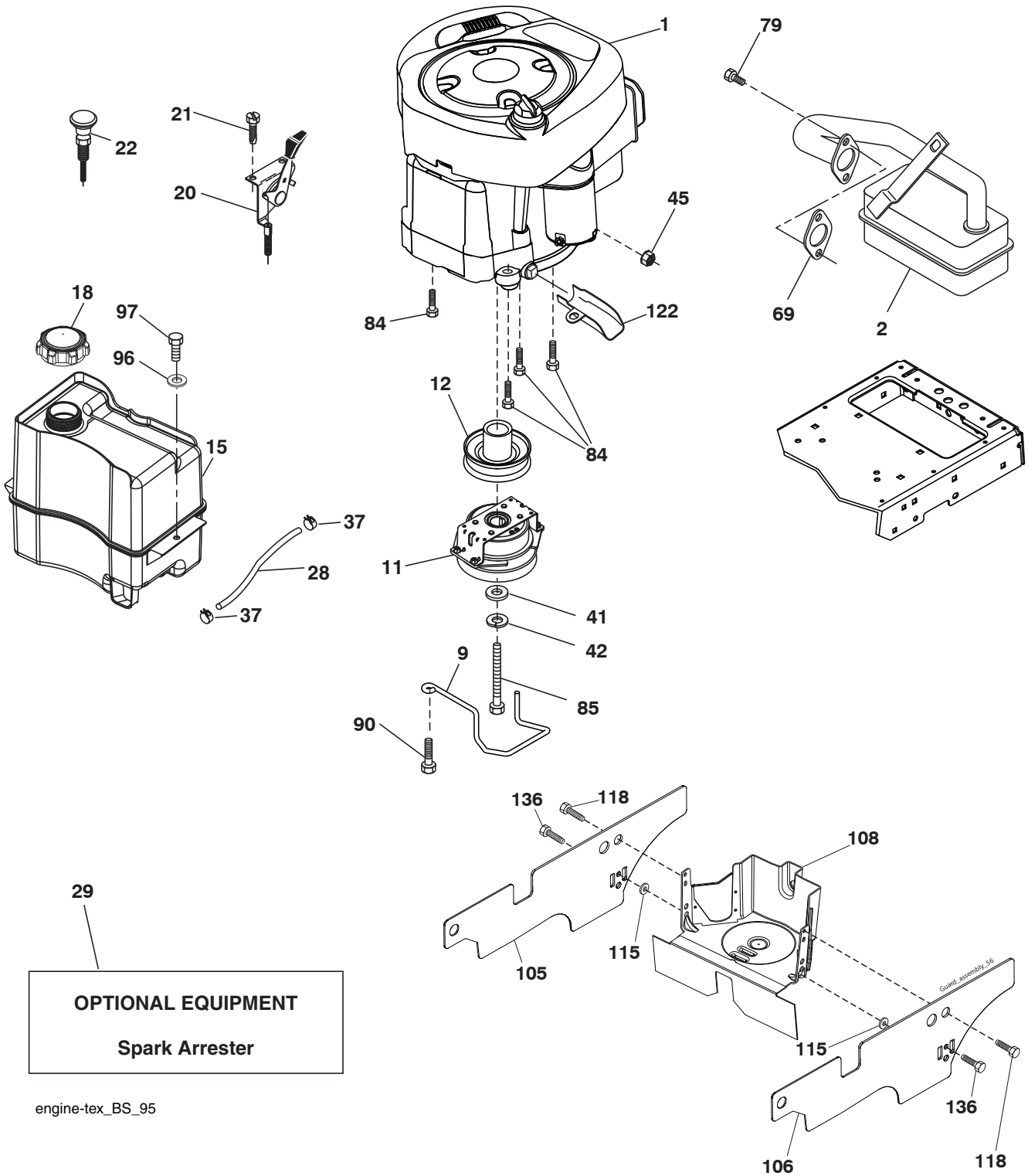

**TRACTOR - - MODEL NO. M185-117T (96041029701), PRODUCT NO. 960 41 02-97
ENGINE 24**

KEY NO.	PART NO.	DESCRIPTION
1	-----	Engine Briggs Model No. 31N707-2437-B1 (438593) (Order parts from engine manufacturer.)
2	532 13 73-52	Muffler
9	532 19 43-20	Keeper Belt Engine
11	587 24 16-01	Clutch Electric
12	532 40 50-97	Pulley Engine
15	532 43 08-25	Tank Fuel
18	532 43 02-20	Cap Asm
20	532 40 15-08	Control Throttle
21	532 41 63-58	Screw #10 x 0.750 BOS Thread
22	532 19 49-81	Control Choke
28	532 13 70-40	Fuel Line
29	532 13 71-80	Spark Arrester Kit
37	532 12 34-87	Clamp Hose
41	532 12 61-97	Washer 1-1/2 OD x 15/32 ID x .250
42	810 04 07-00	Washer Lock 7/16
45	873 51 04-00	Nut Keps Hex 1/4-20 unc
69	532 16 52-91	Gasket
79	532 19 23-34	Screw 5/16-18 x .75
84	817 06 06-20	Screw 3/8-16 x 1-1/4
85	532 17 99-53	Bolt 7/16-20 x 3.75 Gr.
90	817 00 06-16	Screw 3/8-16 x 1
96	819 09 14-16	Washer 9/32 x 7/8 x 16 Ga.
97	817 67 04-12	Screw 1/4 - 20 x 3/4
105	532 41 56-06	Shield Side LH
106	532 41 56-11	Shield Side RH
108	532 42 68-03	Cover Asm. Pulley
115	532 42 30-62	Palnut 1/4
118	817 67 05-08	Screw Thdrol 5/16-18 x 1/2
122	532 42 19-22	Extension Drain Oil
136	532 13 77-29	Screw Thdrol 1/4-20 x 5/8

NOTE: All component dimensions given in U.S. inches
1 inch = 25.4 mm

Engine Power Rating Information

The gross power rating for individual gas engine models is labeled in accordance with SAE (Society of Automotive Engineers) code J1940 (Small Engine Power & Torque Rating Procedure), and rating performance has been obtained and corrected in accordance with SAE J1995 (Revision 2002-05). Torque values are derived at 3060 RPM; horsepower values are derived at 3600 RPM. Actual gross engine power will be lower and is affected by, among other things, ambient operating conditions and engine-to-engine variability. Given both the wide array of products on which engines are placed and the variety of environmental issues applicable to operating the equipment, the gas engine will not develop the rated gross power when used in a given piece of power equipment (actual "on-site" or net power). This difference is due to a variety of factors including, but not limited to, accessories (air cleaner, exhaust, charging, cooling, carburetor, fuel pump, etc.), application limitations, ambient operating conditions (temperature, humidity, altitude), and engine-to-engine variability. Due to manufacturing and capacity limitations, Briggs & Stratton may substitute an engine of higher rated power for this Series engine.

TRACTOR -- MODEL NO. M185-117T (96041029701), PRODUCT NO. 960 41 02-97
STEERING ASSEMBLY **41**

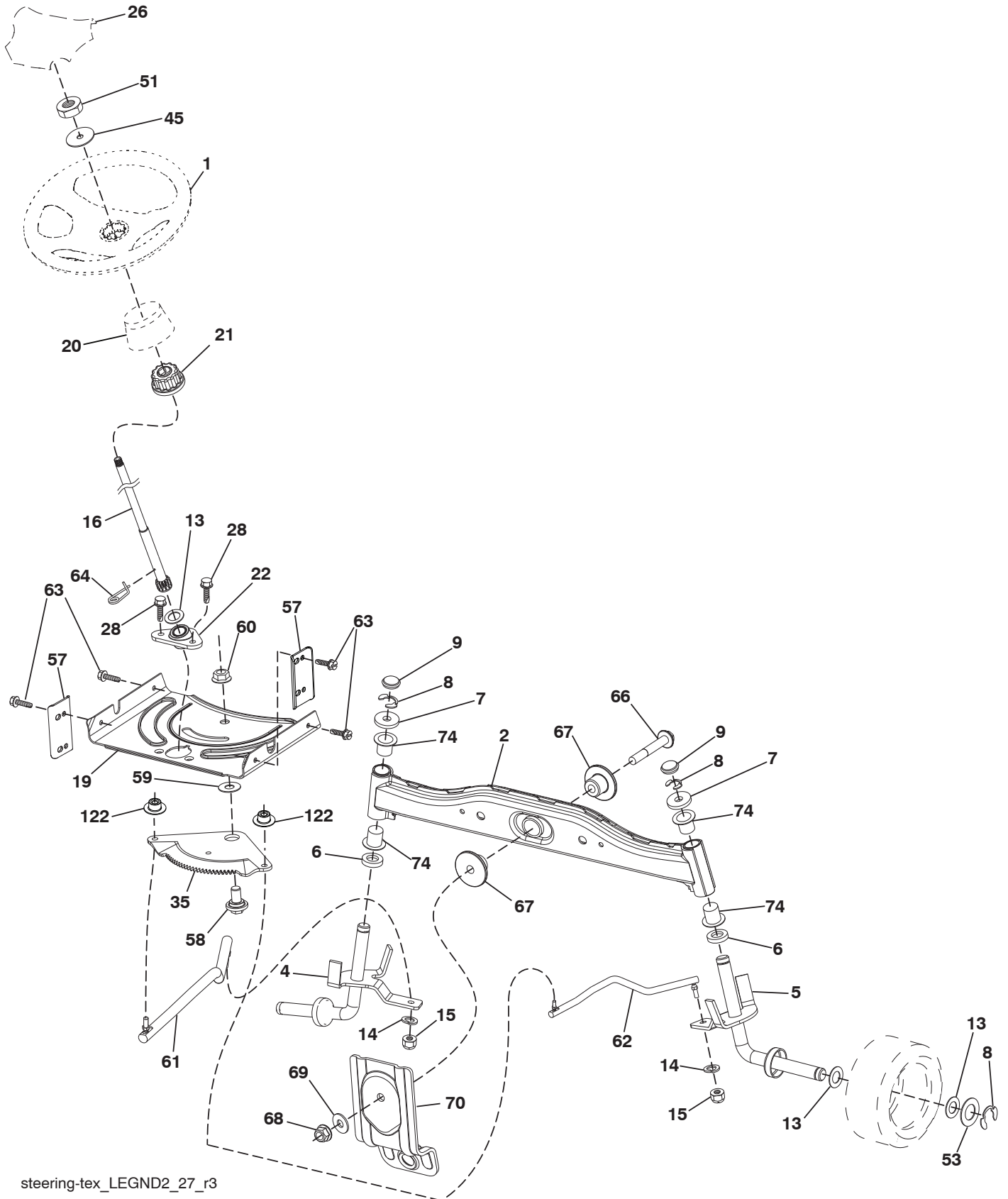

steering-tex_LEGND2_27_r3

**TRACTOR - - MODEL NO. M185-117T (96041029701), PRODUCT NO. 960 41 02-97
STEERING ASSEMBLY 41**

KEY NO.	PART NO.	DESCRIPTION
1	532 44 28-04	Wheel, Steering
2	532 41 81-68	Axle Asm., Front
4	532 40 30-87	Spindle Asm., LH
5	532 40 30-88	Spindle Asm., RH
6	532 12 49-31	Bearing, Race Thrust Harden
7	532 12 17-48	Washer 25/32 x 1-5/8 x 16 Ga.
8	812 00 00-29	Ring, Clip #T5304-75
9	532 12 12-32	Cap, Spindle
13	532 12 17-49	Washer 25/32 x 1-1/4 x 16 Ga.
14	810 04 06-00	Washer, Lock Hvy Hlcl Spr 3/8
15	873 54 06-00	Nut, Crown Lock 3/8-24 unf
16	532 19 47-46	Shaft Steering
19	532 19 47-29	Plate Steering
20	532 42 47-40	Boot Steering
21	532 18 67-37	Adapter, Wheel Steering
22	532 42 05-37	Steering Support Lower
26	532 44 77-59	Insert, Wheel Steering
28	817 00 06-12	Screw 3/8-16 x 3/4
35	532 19 47-32	Gear, Sector Plate
45	819 18 38-12	Washer 9/16 x 2-3/8 12 Ga.
51	873 94 08-00	Nut Hex Jam Toplock 1/2-20 unf
53	532 18 89-67	Washer Hardened .793 x 1.637 x .060
57	532 40 74-65	Bracket Upstop
58	532 19 47-47	Bolt Shoulder Sector Pivot CFM
59	532 19 47-48	Washer Thrust Sector Steering
60	873 97 10-00	Nut Flange Lock 5/8-11
61	532 19 47-40	Draglink LH
62	532 19 47-41	Draglink, RH
63	817 00 05-12	Screw 5/16-18 x 3/4
64	532 19 98-49	Retainer Clip Spring Steering
66	871 02 07-48	Bolt Hex Fghd 7/16-14 x 3 Serr
67	532 19 47-37	Bushing PM Front Axle
68	873 90 07-00	Nut Lock Flange 7/16-14 Gr. 5
69	532 19 91-62	Washer 1.5 x .505 x .118
70	532 19 61-97	Bracket Deck Susp. Front
74	532 12 49-37	Bearing
122	532 44 49-62	Cap Gear Sector

NOTE: All component dimensions given in U.S. inches
1 inch = 25.4 mm

TRACTOR -- MODEL NO. M185-117T (96041029701), PRODUCT NO. 960 41 02-97
 MOWER DECK **44**

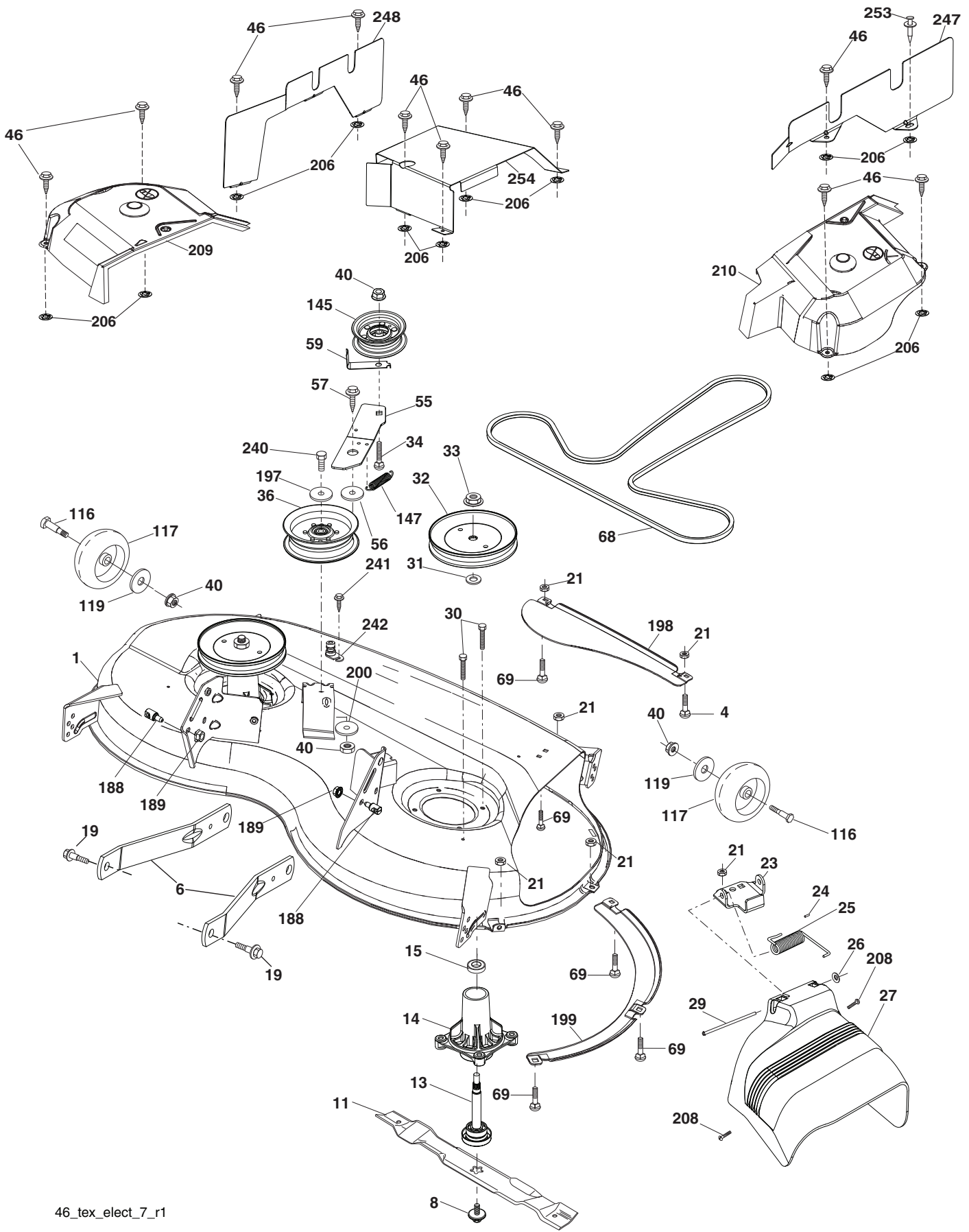

46_tex_elect_7_r1

**TRACTOR - - MODEL NO. M185-117T (96041029701), PRODUCT NO. 960 41 02-97
MOWER DECK 44**

KEY NO.	PART NO.	DESCRIPTION	KEY NO.	PART NO.	DESCRIPTION
1	532 44 16-16	Mower Housing	117	532 17 48-73	Wheel, Gauge
4	874 76 05-12	Bolt Hex HD 5/16-18	119	819 13 20-12	Washer 13/32 x 1-1/4 x 12 Ga.
6	532 19 51-86	Arm Suspension	145	532 19 73-79	Pulley Idler
8	532 19 30-03	Bolt/Washer Asm 7/16-20 unf	147	532 19 72-51	Spring Mower Drive Electric
11	532 40 53-80	Blade	188	532 19 51-61	Stud Fastener
13	532 19 28-72	Shaft Assembly, Mandrel	189	873 90 05-00	Nut Lock Hex Flange
14	532 18 72-81	Housing, Mandrel	197	819 13 13-12	Washer 13/32 x 13/16 x 12 Ga.
15	532 11 04-85	Bearing, Ball, Mandrel	198	532 40 31-49	Baffle Center Front
19	532 19 65-39	Bolt, Shoulder	199	532 40 31-50	Baffle Front RH
21	873 68 05-00	Nut, Crownlock 5/16-18 unc	200	532 41 35-24	Washer 13/32 x 1 x 1/2 x 11 Ga.
23	532 19 25-57	Bracket, Deflector	206	532 42 30-62	Palnut 1/4
24	532 10 53-04	Cap, Sleeve	208	817 67 06-08	Screw 3/8-16 x 1/2
25	532 19 70-26	Spring, Torsion, Deflector	209	532 43 23-95	Cover Mandrel LH
26	532 11 04-52	Nut, Push	210	532 43 23-96	Cover Mandrel RH
27	532 44 28-95	Shield, Deflector	240	874 52 06-36	Bolt Fin Hex 3/8-16 x 2-1/4 Gr. 5
29	532 13 14-91	Rod, Hinge	241	532 15 29-27	Screw #10-32.5 3/8 Flange
30	532 17 39-84	Screw Thdrol Rolling Wsh Hd	242	532 41 55-98	Port Washout
31	532 18 76-90	Washer, Spacer	247	532 43 02-63	Shield Deck RH
32	532 19 74-73	Pulley, Mandrel	248	532 43 02-62	Shield Deck LH
33	532 40 02-34	Nut, Toplock, Flanged	253	532 42 73-50	Rivet Tuflok .25 x .24
34	872 11 06-12	Bolt Carr Sh. 3/8-16 x 1-1/2 Gr. 5	254	532 43 02-64	Shield Deck Rear
36	532 19 31-97	Pulley, Idler, Primary	--	532 19 28-70	Mandrel Assembly (Includes Housing (key #14), Shaft Assembly(key #13), Bearing (key #15) and nut (key # 33)Only - Pulley/Nut/Washer And BladeBolt/Washers Not Included.)
40	873 90 06-00	Nut, Lock Flg. 3/8-16 unc	--	532 42 72-24	Replacement Mower, Complete
46	532 13 77-29	Screw Thdrol 1/4-20 x 5/8			
55	532 19 72-49	Arm, Idler			
56	532 19 90-92	Spacer, Retainer			
57	817 00 06-16	Screw 3/8-16 x 1			
59	532 14 10-43	Guard, Tuv Idler			
68	532 40 51-43	Belt, Drive			
69	872 14 05-05	Bolt			
116	532 19 34-06	Bolt, Shoulder			

NOTE: All component dimensions given in U.S. inches
1 inch = 25.4 mm

TRACTOR - - MODEL NO. M185-117T (96041029701), PRODUCT NO. 960 41 02-97
MOWER LIFT 45

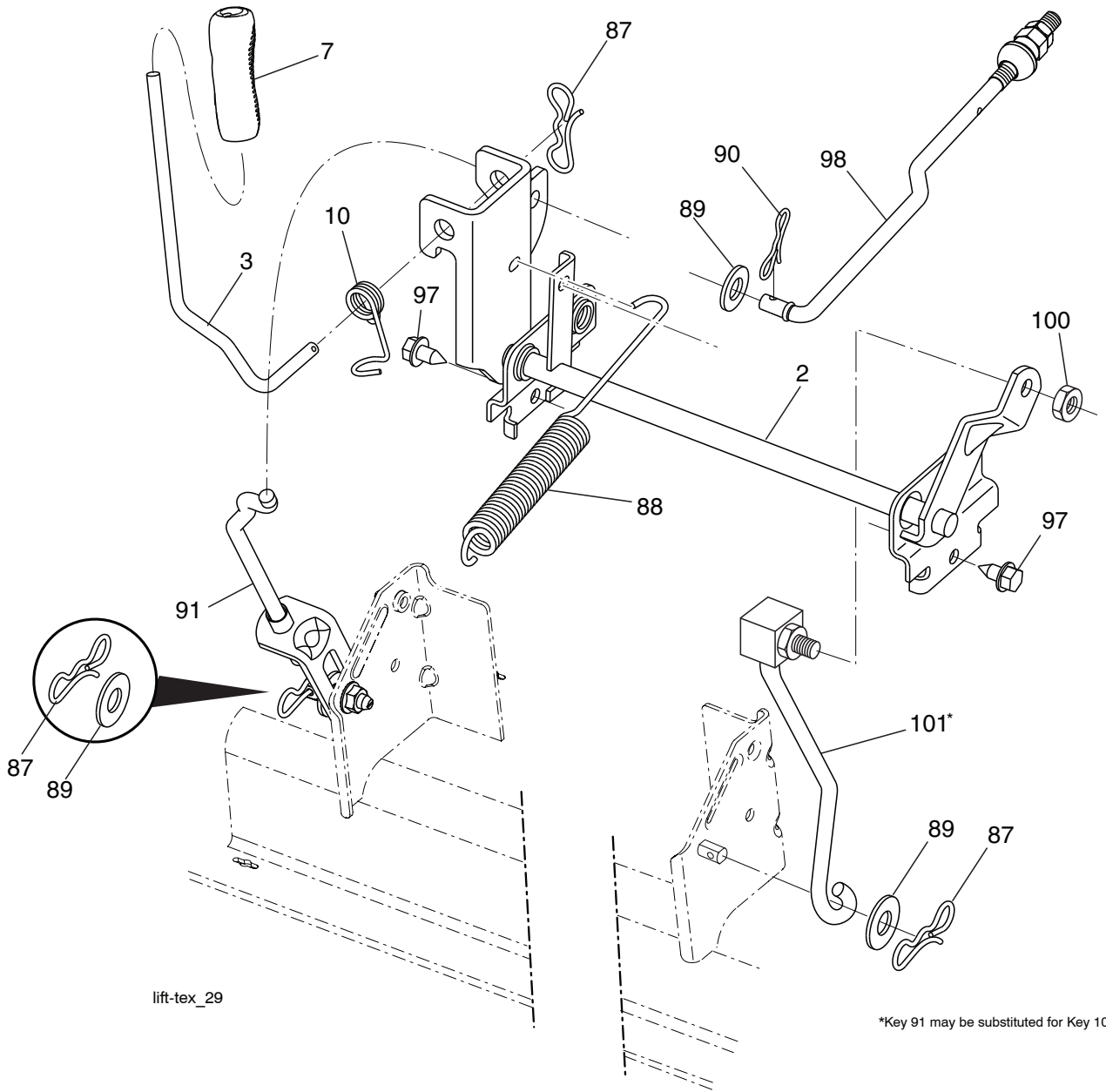

lift-tex_29

*Key 91 may be substituted for Key 101

KEY NO.	PART NO.	DESCRIPTION
2	532 42 20-27	Shaft Asm., Lift
3	532 19 52-31	Lever Asm., Lift RH
7	580 96 23-01	Grip, Lever
10	532 19 63-14	Spring Torsion
87	532 19 42-09	Pin Cotter 7/16 Bow Tie Lock
88	532 41 07-10	Spring Lift Assist
89	819 19 19-12	Washer 17/32 x 1-3/16 x 12 Ga.
90	532 19 42-08	Pin Cotter 5/16 Bow Tie Lock
91	532 19 51-81	Link Lift Susp Mower Rear

KEY NO.	PART NO.	DESCRIPTION
97	817 00 06-12	Screw 3/8-16 x .75
98	532 19 52-70	Link Lift Susp. Front Mower
100	873 93 06-00	Nut Centerlock 3/8-16 unc
101	532 40 70-03	Link Asm. Lift Fixed

NOTE: All component dimensions given in U.S. inches
 1 inch = 25.4 mm

**TRACTOR - - MODEL NO. M185-117T (96041029701), PRODUCT NO. 960 41 02-97
SEAT ASSEMBLY 42**

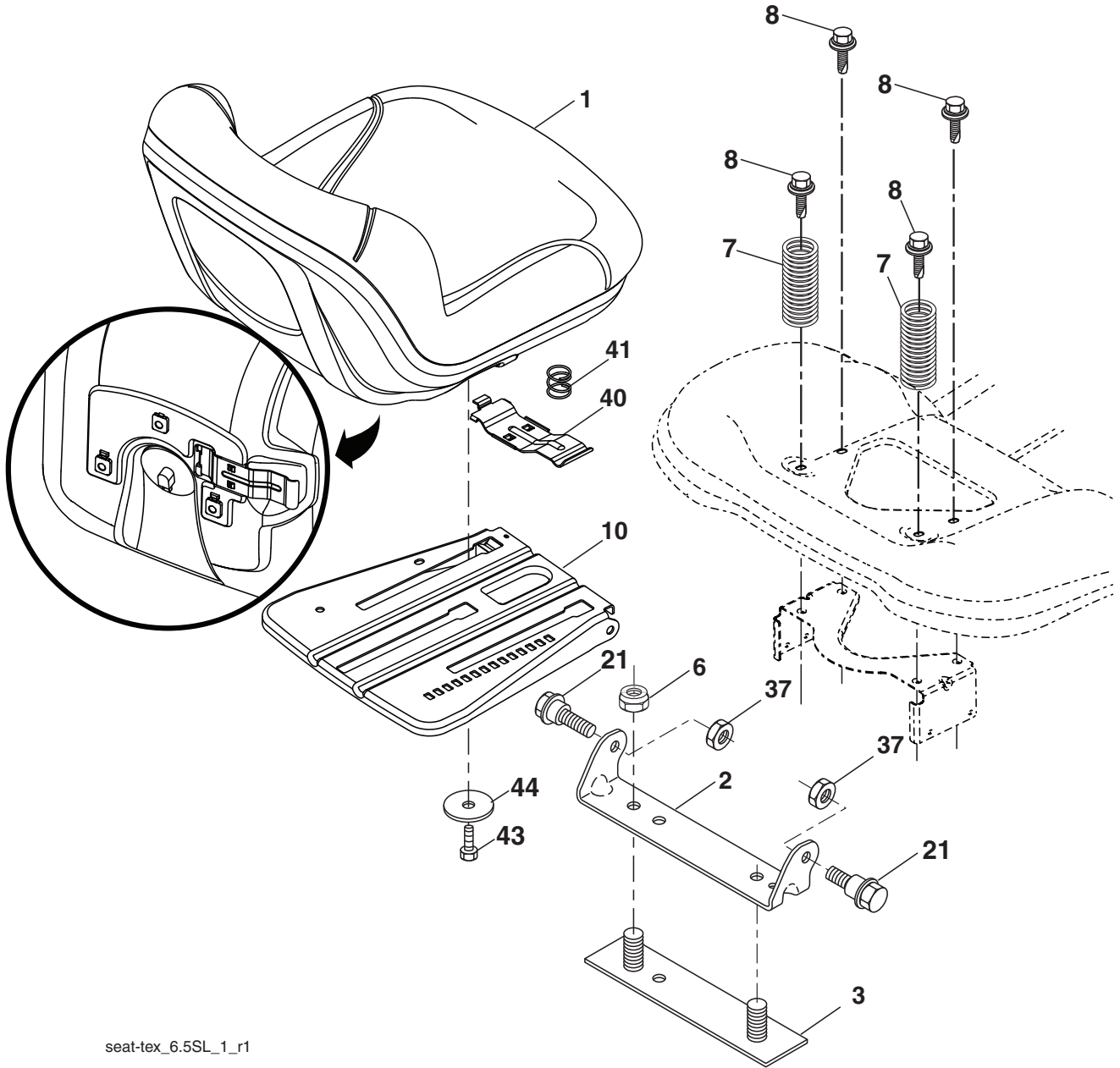

seat-tex_6.5SL_1_r1

KEY NO.	PART NO.	DESCRIPTION
1	581 46 22-01	Seat
2	532 18 01-66	Bracket Pivot Fender
3	532 14 06-75	Strap, Asm Fender
6	873 80 06-00	Nut, Lock w/Ins. 3/8-16 unc
7	532 12 41-81	Spring, Seat Cprsn
8	532 17 18-77	Bolt 5/16-18 unc x 3/4 w/Sems
10	532 19 69-77	Pan, Seat
21	532 17 18-52	Bolt, Shoulder 5/16-18

KEY NO.	PART NO.	DESCRIPTION
37	873 80 05-00	Nut, Lock 5/16-18 unc
40	532 19 76-61	Handle Slide Seat
41	532 19 82-00	Spring Latch Seat
43	874 76 06-12	Bolt 3/8-16 x 3/4
44	819 13 38-12	Washer 13/32 x 2-3/8 x 12 Ga.

NOTE: All component dimensions given in U.S. inches
1 inch = 25.4 mm

