

ILLUSTRATED PARTS LIST

MFG. ID NO. 96051005801

CUSTOMER CATALOG NO. M115-77TC

PRODUCT NO. 960 51 00-58

TRACTOR - MODEL NO. M115-77TC (96051005801), PRODUCT NO. 960 51 00-58
DECALS 27

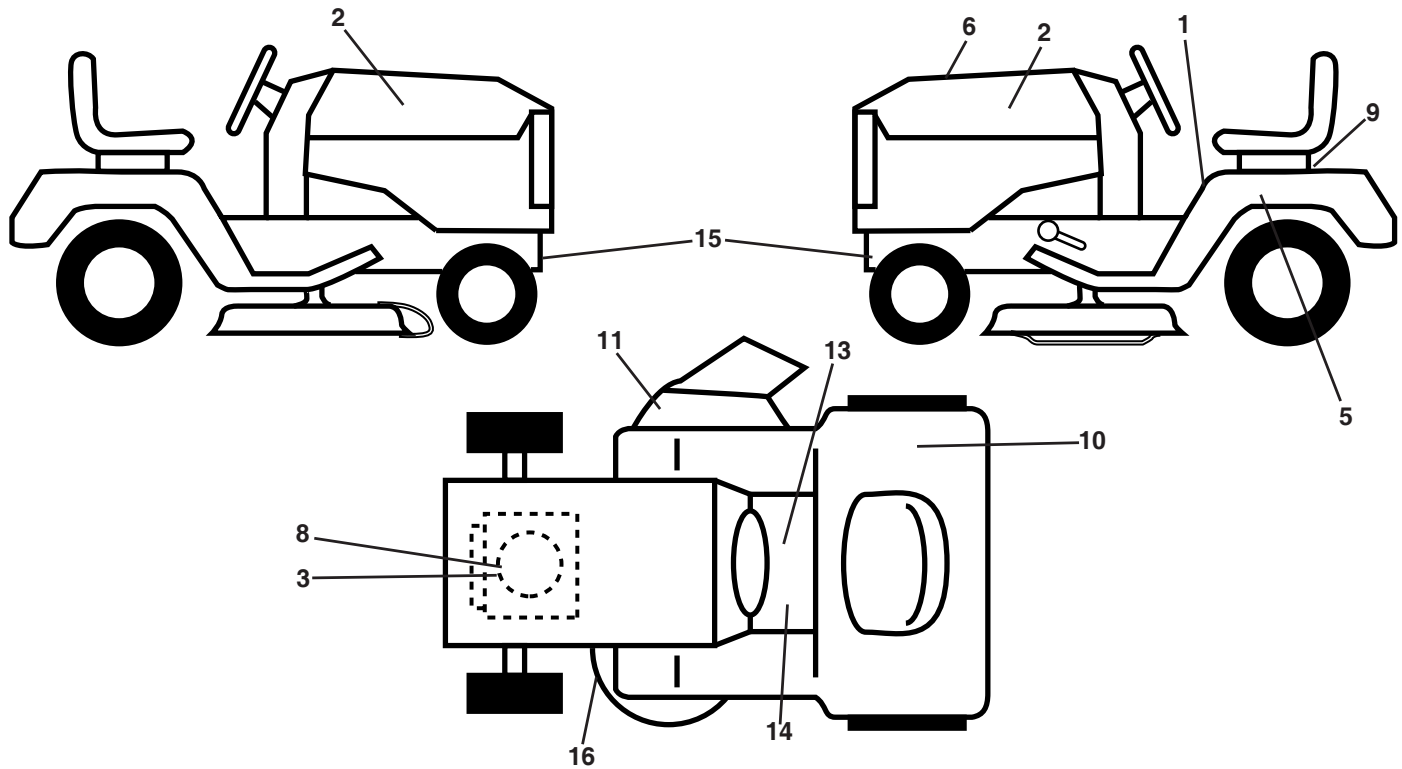

KEY NO.	PART NO.	DESCRIPTION
1	581 57 81-01	Decal, Warning Symbols
2	581 09 12-01	Decal, Hood
3	581 57 97-01	Decal, Engine Warning
5	581 60 79-02	Decal, Fender
6	532 44 32-41	Decal, Replacement
8	532 43 74-09	Decal, Engine HP
9	532 14 50-05	Decal, Battery Dnge/Poi
10	581 72 41-01	Decal, Fender DBA
11	581 57 94-01	Decal, Warning
13	581 57 80-01	Decal, Saddle Brake Parking

KEY NO.	PART NO.	DESCRIPTION
14	581 72 40-01	Decal, Brake/Clutch Symbol
15	581 57 96-01	Decal, Chassis Hot Muffler
16	581 58 00-04	Decal, V-Belt Schematic
--	532 42 59-76	Pad, Footrest, LH
--	532 42 59-28	Pad, Footrest, RH
--	581 41 90-40	Manual, Operator's (Euro)
--	581 41 91-50	Manual, Operator's (Scan)
--	581 41 93-20	Manual, Operator's (EBloc)
--	581 41 94-30	Manual, Operator's (Baltic)

WHEELS AND TIRES

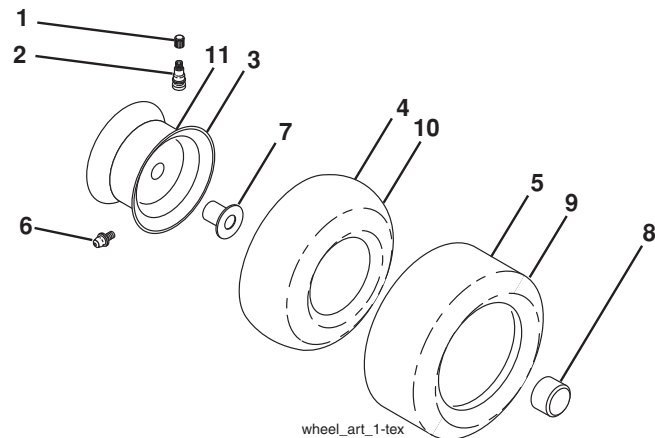

KEY NO.	PART NO.	DESCRIPTION
1	532 05 91-92	Cap Valve Tire
2	532 06 51-39	Stem Valve
3	532 42 53-61	Rim Asm 6" x 3.25 Front
4	532 42 16-52	Tube Front (Service Item Only)
5	532 12 34-10	Tire Front 13 x 5.0-6
6	532 12 49-57	Fitting Grease (Front Wheel Only)
7	532 12 49-59	Bearing Flange (Front Wheel Only)
8	532 19 32-68	Cap Axle
9	532 10 62-30	Tire Rear 16 x 6 - 5
10	532 00 71-54	Tube Rear (Service Item Only)
11	532 42 53-62	Rim Asm 8" x 5.375 Rear
--	532 14 43-34	Sealant, Tire (10 oz. Tube)

NOTE: All component dimensions given in U.S. inches
 1 inch = 25.4 mm

TRACTOR - MODEL NO. M115-77TC (96051005801), PRODUCT NO. 960 51 00-58 SCHEMATIC 38

SCH17

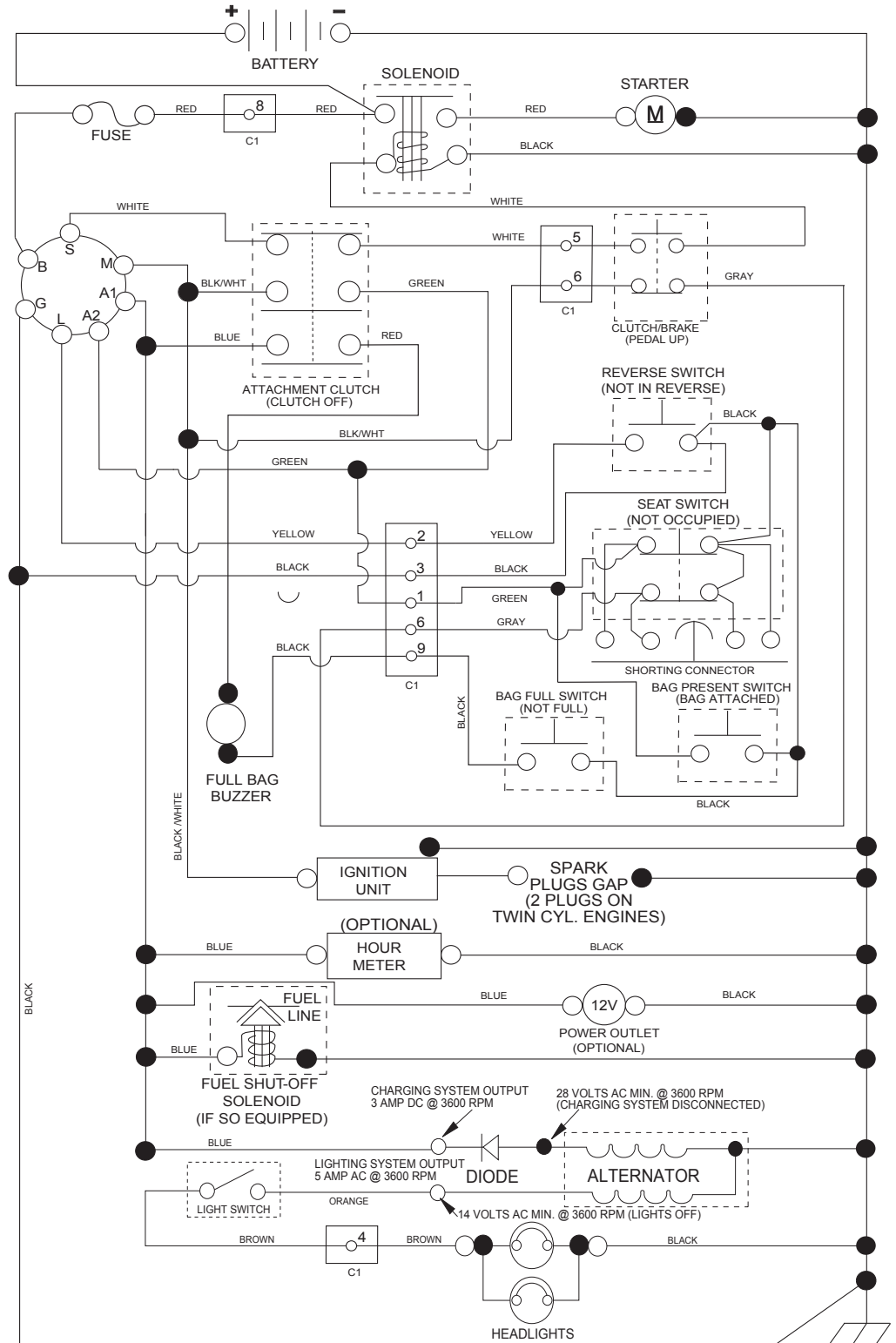

NOTE
YOUR TRACTOR IS EQUIPPED WITH A SPECIAL ALTERNATOR SYSTEM. THE LIGHTS ARE NOT CONNECTED TO THE BATTERY, BUT HAVE THEIR OWN ELECTRICAL SOURCE. BECAUSE OF THIS, THE BRIGHTNESS OF THE LIGHTS WILL CHANGE WITH ENGINE SPEED. AT IDLE THE LIGHTS WILL DIM. AS THE ENGINE SPEED IS INCREASED, THE LIGHTS WILL BECOME THEIR BRIGHTEST.

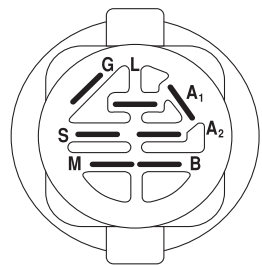

POSITION	CIRCUIT	"MAKE"
OFF	M+G+A1	
RUN/OVERRIDE	B+A1	
RUN	B+A1	L+A2
START	B + S + A1	

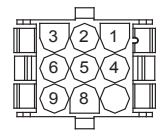
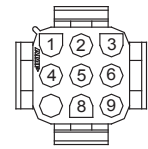

WIRING INSULATED CLIPS
NOTE: IF WIRING INSULATED CLIPS WERE REMOVED FOR SERVICING OF UNIT, THEY SHOULD BE RE-INSTALLED TO PROPERLY SECURE YOUR WIRING.

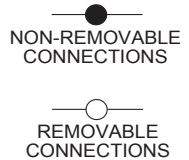

TRACTOR - MODEL NO. M115-77TC (96051005801), PRODUCT NO. 960 51 00-58
ELECTRICAL 32

S01S

Service Minder (If Equipped)

46

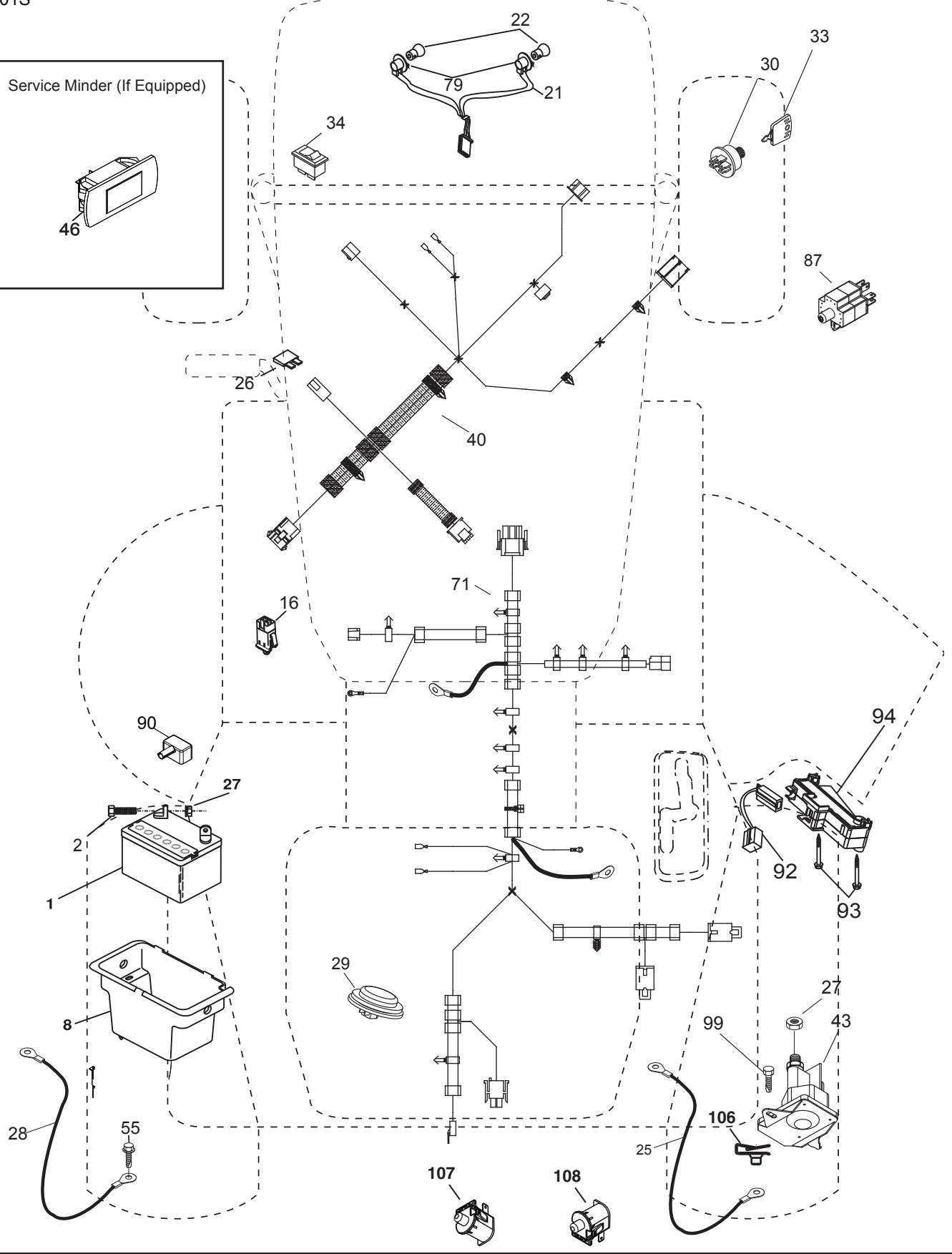

**TRACTOR - MODEL NO. M115-77TC (96051005801), PRODUCT NO. 960 51 00-58
ELECTRICAL 32**

KEY NO.	PART NO.	DESCRIPTION
1	532 14 49-24	Battery
2	874 76 04-12	Bolt Hex Head 1/4-20 x 3/4
8	532 41 97-91	Box Battery
16	532 17 61-38	Switch Interlock Push-In
21	532 40 02-52	Harness Socket Light w/4152J
22	532 00 41-52	Bulb Light
25	532 41 66-94	Cable Battery
26	532 17 51-58	Fuse
27	873 51 04-00	Nut Keps Hex 1/4-20 unc
28	532 42 16-86	Cable, Ground
29	532 40 15-45	Switch, Seat
30	532 19 33-50	Switch, Ign
33	532 41 19-35	Key/Chain
34	532 11 07-12	Switch Light/Reset
40	532 42 10-02	Harness Ign. Dash
43	532 19 25-07	Solenoid
55	817 06 05-12	Screw Thdrol 5/16-18 x 3/4
71	532 42 94-12	Harness Chassis
79	532 17 52-42	Socket Asm Bulb Twistlock
87	532 42 10-60	Switch Railmount
90	532 43 53-95	Cover, Terminal Battery
92	532 19 66-15	Harness Pigtail
93	532 19 25-40	Screw Plastite 10-14 x 2.0
94	532 19 18-34	Module Reverse
99	817 67 04-12	Screw 1/4-20 x 3/4
106	532 17 48-14	Palnut 1/4 Lugs
107	532 42 10-61	Switch Snap Mount No. #2
108	532 42 10-62	Switch Snap Mount NC

NOTE: All component dimensions given in U.S. inches
1 inch = 25.4 mm

TRACTOR - MODEL NO. M115-77TC (96051005801), PRODUCT NO. 960 51 00-58
CHASSIS AND ENCLOSURES **39**

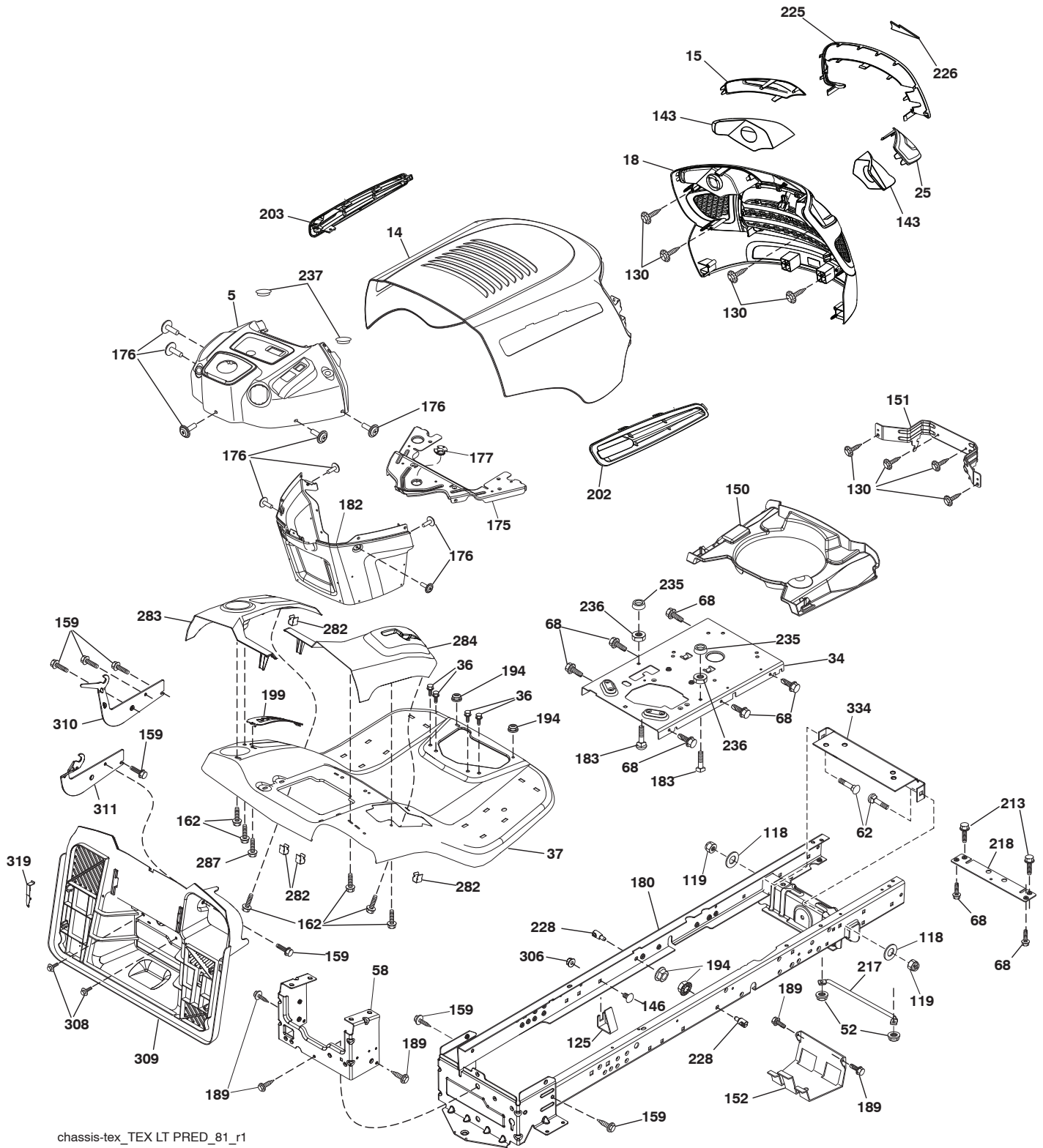

chassis-tex_TEX LT PRED_81_r1

**TRACTOR - MODEL NO. M115-77TC (96051005801), PRODUCT NO. 960 51 00-58
CHASSIS AND ENCLOSURES **39****

KEY NO.	PART NO.	DESCRIPTION
5	532 42 57-72	Dash
14	581 56 47-01	Hood
15	581 05 58-01	Lens LH
18	581 05 57-01	Grille
25	581 05 59-01	Lens RH
34	580 91 09-01	Plate Engine
36	817 06 05-12	Screw 5/16-18 x 3/4
37	532 43 96-24	Fender
52	873 68 05-00	Nut Crown Lock 5/16
58	532 41 22-80	Drawbar Upper
62	872 11 06-08	Bolt 3/8-16 x 1 Gr. 5
68	817 49 05-08	Screw Thdrol. 5/16-18 x 1/2
118	819 13 13-16	Washer 13/32 x 13/16 x 16 Ga.
119	873 68 06-00	Nut Crownlock 3/8-16 unc
125	581 68 48-01	Clip Fuel Line
130	532 41 63-58	Screw #10 x 0.750 BOS Thread
143	581 05 60-02	Insert Reflective LH/RH
146	581 85 79-01	Bolt
150	532 40 02-67	Air Duct
151	532 18 75-68	Bracket Pivot Hood
152	532 19 95-35	Shield Browning
159	817 00 06-12	Screw Hex Wsh Thdr 3/8-16 x 3/4
162	532 14 24-32	Screw Hex Wsh. Hi-Lo 1/4 x 1/2 unc
175	532 19 94-72	Crossmember
176	532 40 07-76	Screw 10-24 x 5/8
177	532 19 52-28	Bushing Steering
180	532 41 46-85	Chassis
182	532 40 71-76	Dash Lower
183	874 78 05-20	Bolt 5/16-18 unc x 1-1/4
189	817 00 05-12	Screw 5/16-18 x 3/4
194	873 90 05-00	Nut Lock Hex Flange 5/16-18
199	532 41 87-39	Plate Deck Lift
202	581 56 49-01	Vent Side RH
203	581 56 48-01	Vent Side LH
213	874 76 05-12	Bolt 5/16-18 x 3/4
217	532 40 91-67	Rod Pivot Hood
218	532 19 63-95	X-Piece Hood Stop
225	581 05 62-01	Trim Ring
226	578 89 71-01	Emblem
228	532 19 51-61	Stud Fastener
235	532 40 61-29	Spacer Fender
236	873 93 05-00	Nut Lock 5/16-18 unc
237	532 40 37-04	Plug Mount Cargo
282	532 41 41-10	Clip Retainer
283	532 44 03-61	Console Deck Lift
284	532 44 05-28	Console Shift
287	817 60 04-06	Screw Hex Washhead 1/4-20 x 3/8
306	873 90 06-00	Nut Lock
308	532 17 18-77	Bolt 5/16-18 unc x 3/4
309	532 43 02-46	Backplate Bagger SRD
310	532 44 66-36	Bracket Hangar Bag LH
311	532 44 66-37	Bracket Hangar Bag RH
319	532 17 46-62	Bracket Actuator
334	532 44 25-37	Bracket Engine

NOTE: All component dimensions given in U.S. inches
1 inch = 25.4 mm

TRACTOR - MODEL NO. M115-77TC (96051005801), PRODUCT NO. 960 51 00-58
DRIVE **40**

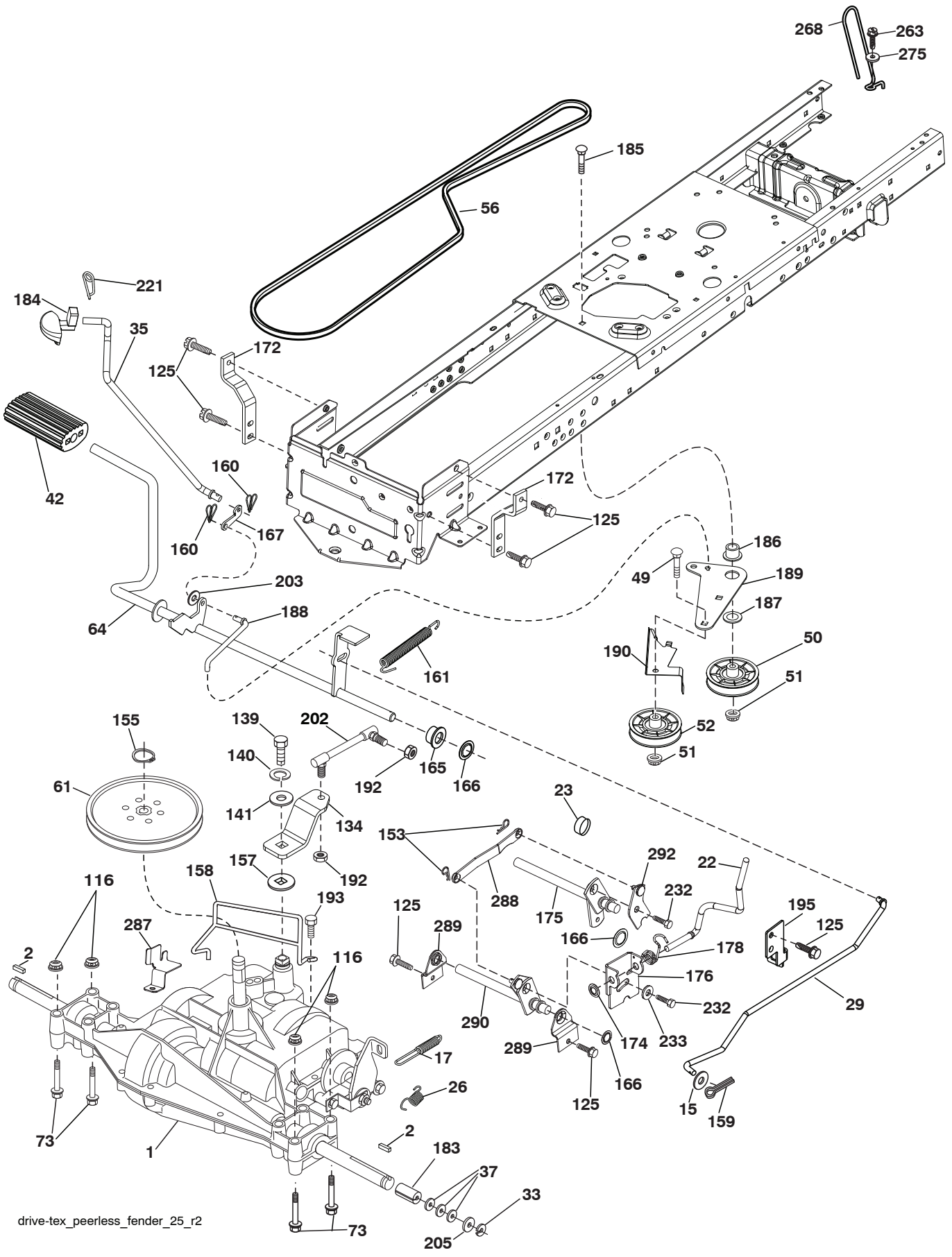

drive-tex_peerless_fender_25_r2

**TRACTOR - MODEL NO. M115-77TC (96051005801), PRODUCT NO. 960 51 00-58
DRIVE 40**

KEY NO.	PART NO.	DESCRIPTION	KEY NO.	PART NO.	DESCRIPTION
1	- - - - -	Transaxle, Peerless 206-565 (197941) (Order parts from trans-axle manufacturer.)	166	532 42 91-64	Nut Push .625
2	532 12 35-83	Key Square	167	532 40 52-57	Latch Brake Parking
15	819 13 13-16	Washer 13/32 x 13/16 x 16 Ga.	172	532 19 76-57	Strap Torque LH
17	532 19 72-97	Spring, Brake	174	532 19 72-89	Nut Push
22	532 41 66-14	Rod Shift	175	532 19 78-58	Shaft Asm. Shift
23	532 10 69-33	Knob	176	532 19 62-14	Arm Clevis Rod Shift
26	532 19 74-55	Spring Brake Return	178	532 19 63-14	Spring Shift
29	532 19 72-67	Rod, Brake	183	532 13 70-57	Spacer Axle
33	812 00 00-01	Ring E	184	532 44 14-07	Handle Parking Brake
35	532 40 10-31	Rod, Brake, Park	185	872 11 06-22	Bolt 3/8-16 unc x 2-3/4 Gr. 5
37	532 12 17-49	Washer 25/32 x 1-1/4 x 16 Ga.	186	532 19 43-21	Spacer Retainer
42	532 12 48-72	Cover, Foot Pedal	187	819 13 32-10	Washer
49	872 11 06-14	Bolt	188	532 19 43-23	Link Clutch Ground Drive
50	532 19 43-27	Pulley Idler Flat	189	532 19 43-17	Bellcrank Ground Drive
51	873 90 06-00	Lock Nut 3/8-16	190	532 19 43-18	Keeper Bellcrank Ground Drive
52	532 19 43-26	Idler V-Groove	192	532 15 03-60	Nut Lock Center 1/4-28 Fnthd
56	532 13 82-55	V-Belt, Drive	193	817 06 05-12	Screw 5/16-18 x 3/4
61	532 16 59-99	Pulley Transaxle	195	532 19 73-32	Bracket Brake Rod
64	532 19 62-00	Shaft Asm. Pedal Brake Control	202	532 19 78-59	Link Transaxle
73	874 49 05-40	Bolt Hex Flghd 5/16-18 x 2 1/2 G 5	203	819 11 11-16	Washer 11/32 x 11/16 x 16 Ga.
116	873 90 05-00	Nut Lock Hex Flange 5/16-18	205	532 12 17-48	Washer 25/32 x 1-5/8 16 Ga.
125	817 00 05-12	Screw 5/16-18 x 3/4	221	532 40 31-87	Retainer Spring Clip Handle
134	532 19 78-57	Asm Shift	232	874 78 07-16	Bolt Hex 7/16-14 x 1 Gr. 5
139	874 55 04-12	Bolt 1/4-28 unf Gr. 8 w/Patch	233	532 40 52-96	Washer Serrated
140	810 04 04-00	Washer Lock Hvy Helical 1/4	263	817 00 06-12	Screw Hexwsh THDR 3/8-16 x 3/4
141	819 09 12-10	Washer 9/32 x 3/4 x 10 Ga.	268	532 18 24-02	Guard Muffler
153	532 12 47-88	Retainer Spring 1"	275	819 13 16-14	Washer 13/32 x 1 x 14 Ga.
155	812 00 00-28	Ring Retainer	287	532 42 16-48	Keeper Pulley Transaxle
157	532 10 57-01	Washer Plate Shift	288	532 41 66-17	Link Shift Slave
158	532 19 43-52	Belt Keeper	289	532 41 75-20	Bracket Support Shift Outer
159	876 02 04-12	Pin Cotter 1/8 x 3/4	290	532 42 00-14	Shaft Asm Shift Rear
160	532 16 94-84	Retainer Clip	292	532 41 93-07	Plate Asm Shift
161	532 10 57-09	Spring, Return, Clutch			
165	532 19 62-12	Busing Shaft Brake Hand Control			

NOTE: All component dimensions given in U.S. inches
1 inch = 25.4 mm

TRACTOR - MODEL NO. M115-77TC (96051005801), PRODUCT NO. 960 51 00-58
ENGINE 24

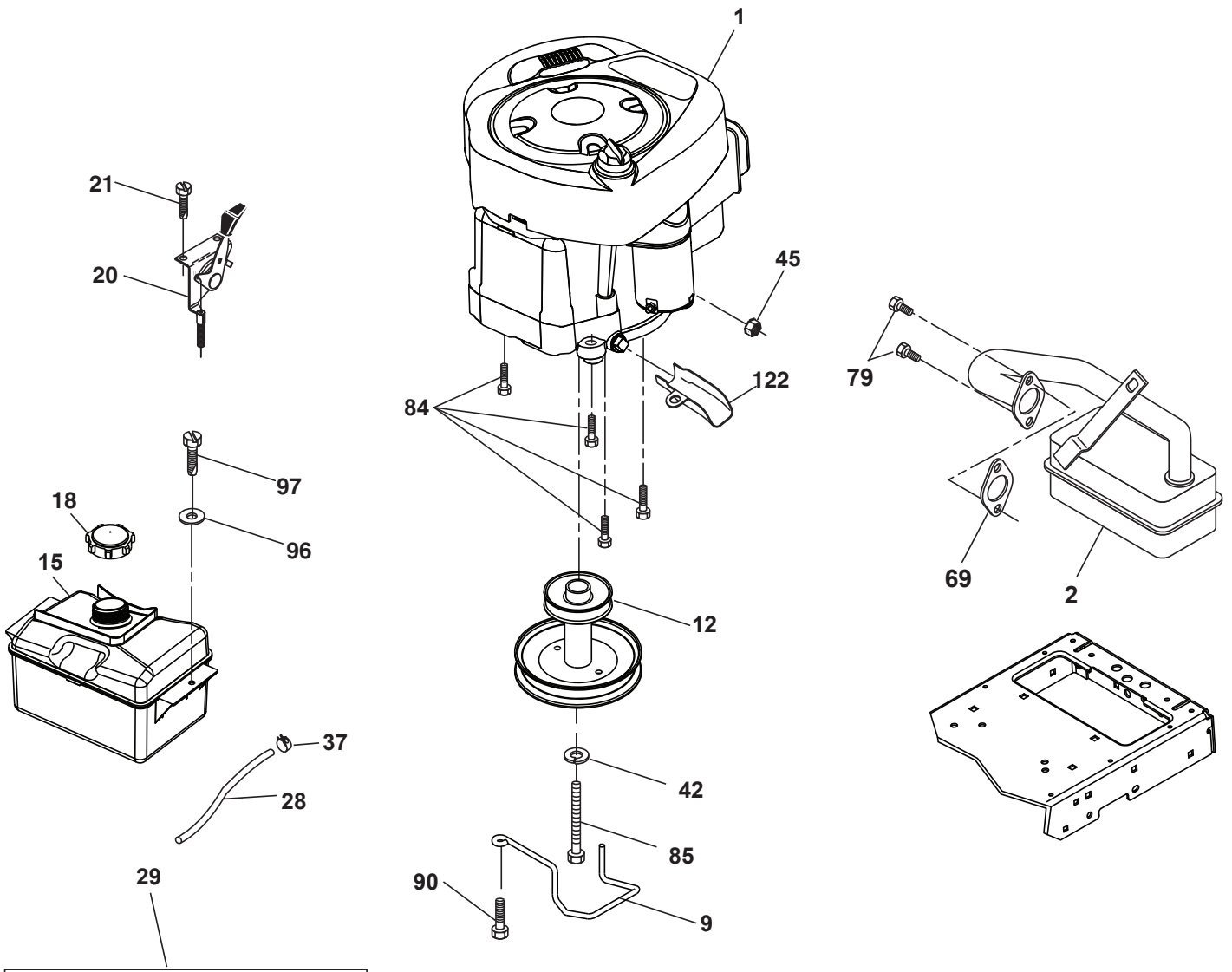

OPTIONAL EQUIPMENT
Spark Arrester

engine-tex_BS_24

**TRACTOR - MODEL NO. M115-77TC (96051005801), PRODUCT NO. 960 51 00-58
ENGINE 24**

KEY NO.	PART NO.	DESCRIPTION
1	- - - - -	Engine Briggs Model No. 21R607-0003-H1 (585579701) (Order parts from engine manufacturer.)
2	532 17 97-58	Muffler
9	584 91 16-01	Keeper Belt Engine
12	532 14 01-86	Pulley Engine
15	581 28 99-01	Tank Fuel
18	532 43 02-20	Cap
20	532 18 38-97	Control Throttle
21	532 41 63-58	Screw #10 x 0.750 BOS Thread
28	532 13 70-40	Fuel Line
29	532 13 71-80	Spark Arrester Kit
37	532 12 34-87	Clamp Hose
42	810 04 07-00	Washer Lock 7/16
45	873 51 04-00	Nut Keps Hex 1/4-20 unc
69	532 16 52-91	Gasket
79	532 19 23-34	Screw 5/16-18 x 3/4
84	817 06 06-20	Screw 3/8-16 x 1/4
85	532 17 39-37	Bolt Hex 7/16-20 x 4 Gr. 5 - 1.5
90	817 00 06-16	Screw 3/8-16 x 1
96	819 09 14-16	Washer 9/32 x 7/8 x 16 Ga.
97	817 67 04-12	Screw 1/4-20 x 3/4
122	532 42 19-22	Extension Drain Oil

NOTE: All component dimensions given in U.S. inches
1 inch = 25.4 mm

Engine Power Rating Information

The gross power rating for individual gas engine models is labeled in accordance with SAE (Society of Automotive Engineers) code J1940 (Small Engine Power & Torque Rating Procedure), and rating performance has been obtained and corrected in accordance with SAE J1995 (Revision 2002-05). Torque values are derived at 3060 RPM; horsepower values are derived at 3600 RPM. Actual gross engine power will be lower and is affected by, among other things, ambient operating conditions and engine-to-engine variability. Given both the wide array of products on which engines are placed and the variety of environmental issues applicable to operating the equipment, the gas engine will not develop the rated gross power when used in a given piece of power equipment (actual "on-site" or net power). This difference is due to a variety of factors including, but not limited to, accessories (air cleaner, exhaust, charging, cooling, carburetor, fuel pump, etc.), application limitations, ambient operating conditions (temperature, humidity, altitude), and engine-to-engine variability. Due to manufacturing and capacity limitations, Briggs & Stratton may substitute an engine of higher rated power for this Series engine.

TRACTOR - MODEL NO. M115-77TC (96051005801), PRODUCT NO. 960 51 00-58
STEERING ASSEMBLY **41**

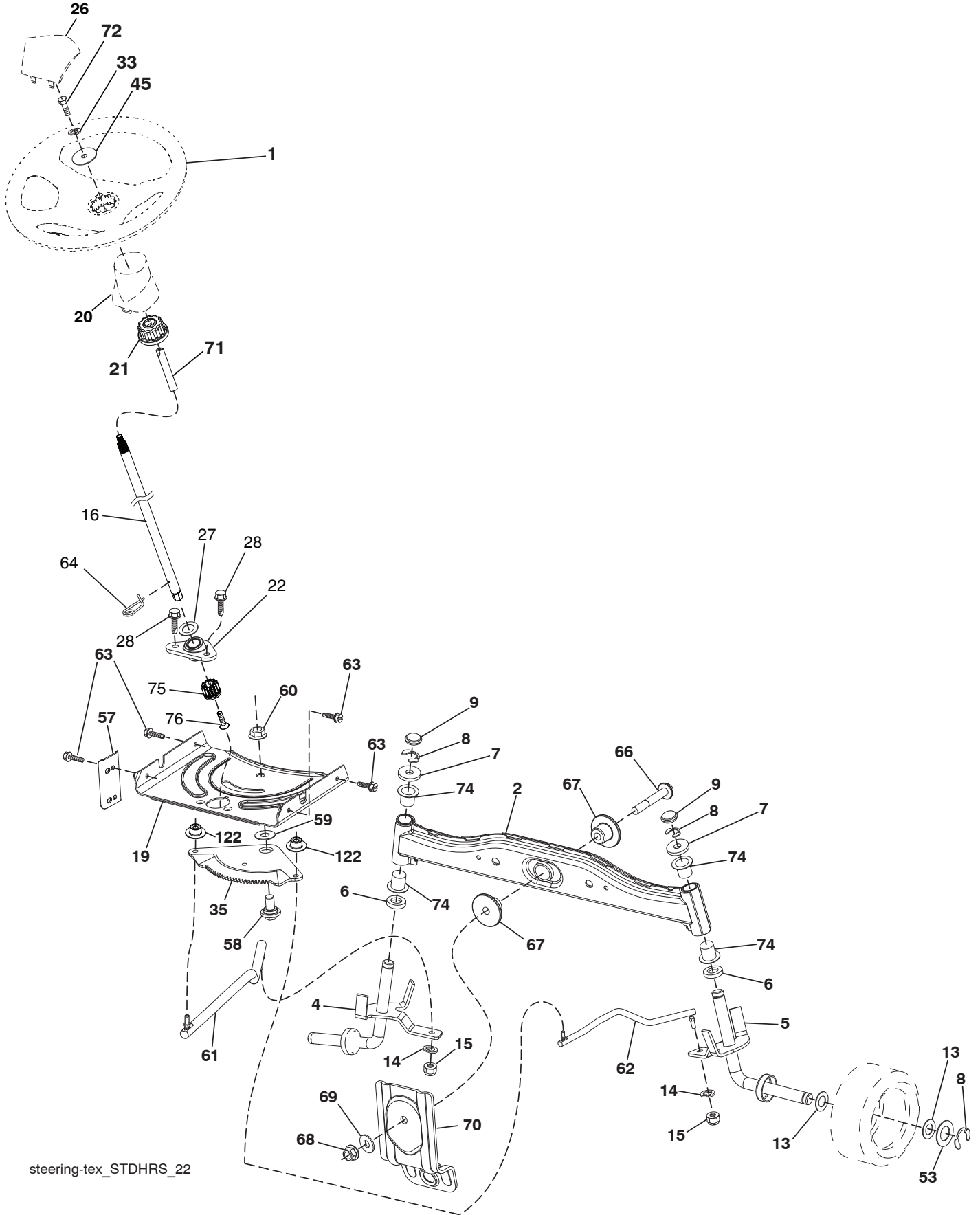

steering-tex_STDHRS_22

**TRACTOR - MODEL NO. M115-77TC (96051005801), PRODUCT NO. 960 51 00-58
STEERING ASSEMBLY **41****

KEY NO.	PART NO.	DESCRIPTION
1	581 78 01-01	Wheel, Steering
2	532 41 81-68	Axle Asm., Front
4	532 41 68-45	Spindle Asm., LH
5	532 41 68-46	Spindle Asm., RH
6	532 12 49-31	Washer Thrust
7	532 12 17-48	Washer 25/32 x 1-5/8 x 16 Ga.
8	812 00 00-29	Ring, Klip #T5304-75
9	532 12 12-32	Cap, Spindle
13	532 12 17-49	Washer 25/32 x 1-1/4 x 16 Ga.
14	810 04 06-00	Washer, Lock Hvy Hlcl Spr 3/8
15	873 54 06-00	Nut, Crown Lock 3/8-24 unf
16	585 86 92-02	Steering Shaft
19	532 19 47-29	Plate Steering
20	532 40 97-63	Boot, Steering
21	532 18 67-37	Adapter, Wheel Steering
22	585 02 98-02	Bearing
26	532 44 77-59	Insert, Wheel Steering
27	819 21 16-16	Washer
28	817 00 06-12	Screw 3/8-16 x 3/4
33	810 04 05-00	Washer Lock 5/16
35	532 19 47-32	Gear, Sector Plate
45	819 11 38-12	Washer 11/32 x 3/8 x 12 Ga.
53	532 18 89-67	Washer Hardened .793 x 1.637 x .060
57	532 40 74-65	Bracket Upstop
58	532 19 47-47	Bolt Shoulder Sector Pivot CFM
59	532 19 47-48	Washer Thrust Sector Steering
60	873 97 10-00	Nut Flange Lock 5/8-11
61	532 19 47-40	Draglink, LH
62	532 19 47-41	Draglink, RH
63	817 00 05-12	Screw 5/16-18 x 3/4
64	532 19 98-49	Retainer Clip Spring Steering
66	871 02 07-48	Bolt Hex Fghd 7/16-14 x 3 Serr
67	532 19 47-37	Bushing PM Front Axle
68	873 90 07-00	Nut Lock Flange 7/16-14 Gr. 5
69	532 19 91-62	Washer 1.5 x .505 x .118
70	532 41 70-65	Bracket Deck Susp. Front
71	532 19 07-52	Shaft Extension Steering
72	532 42 89-82	Bolt Fin Hx 5/16-18 x 4
74	532 12 49-37	Bearing
75	580 68 37-01	Pinion
76	580 68 36-01	Screw Head Sock
122	532 44 49-62	Cap Gear Sector

NOTE: All component dimensions given in U.S. inches
1 inch = 25.4 mm

TRACTOR - MODEL NO. M115-77TC (96051005801), PRODUCT NO. 960 51 00-58
MOWER DECK **44**

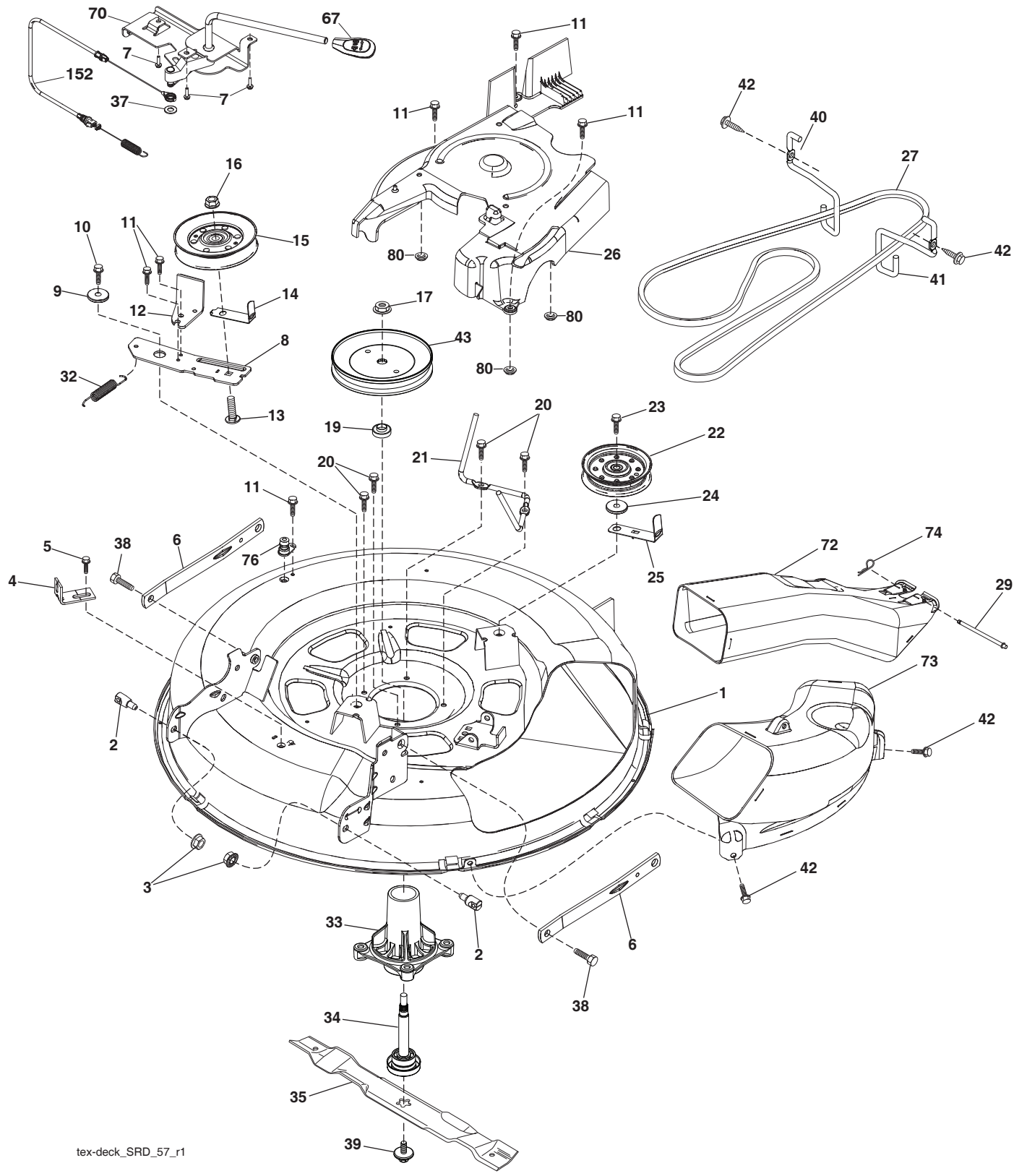

tex-deck_SRD_57_r1

**TRACTOR - MODEL NO. M115-77TC (96051005801), PRODUCT NO. 960 51 00-58
MOWER DECK 44**

KEY NO.	PART NO.	DESCRIPTION	KEY NO.	PART NO.	DESCRIPTION
1	532 41 92-72	Deck Weldment 30"Srd	34	587 25 65-01	Shaft Asm Mndrl N/Greaseable38
2	532 19 51-61	Stud Fastner W/'D'anti-Rotatio	35	532 41 92-74	Blade Mower Bagging Srd
3	873 90 05-00	Nut Lock Hex Flange 5/16 - 18	37	819 13 13-16	Washer 13/32 x 13/16 x 16 Ga.
4	532 41 76-45	Bracket Clutch Cable	38	532 19 65-39	Bolt Shoulder
5	817 00 05-10	Bolt 5/16-18	39	584 30 93-01	Screw 7/16-20 x 1 Hex
6	532 41 88-63	Arm Susp Mower Rear Srd	40	532 41 92-70	Keeper Belt Engine LH
7	532 41 63-58	Screw #10 x 0.750 BOS Thread	41	532 41 92-65	Keeper Belt Engine RH
8	532 42 02-52	Arm Idler 30"Srd	42	817 00 06-12	ScrewHexwshTHDR3/8-16x3/4BL
9	532 19 90-92	Spacer Retainer	43	532 41 68-77	Pulley Mandrel 6 5 Pd 30"
10	817 00 06-16	Screw 3/8 - 16 X 1 Smgml Tap/R Blk	67	532 40 30-12	Handle clutch cable
11	532 13 77-29	Screw Thd Roll 1/4 - 20 X 5/8	70	532 40 12-46	Clutch Asm. Manual
12	532 19 94-70	Arm Brake Mower 38" RH Tex	72	532 41 72-36	Chute Upper SRD 30R
13	872 11 06-12	Bolt Carr Sh 3/8 - 16 X 1 - 1/2 Gr5	73	532 42 52-74	Chute Lower SRD 30R
14	532 15 60-85	Keeper Belt Idler	74	532 12 46-70	Retainer Spring
15	532 14 67-63	Pulley Idler V-Groove Dim 4.25	76	532 41 55-98	Washout Port
16	873 90 06-00	Nut Lock FIG 3/8 - 16 unc	80	532 42 30-62	Palnut 1/4"
17	532 40 02-34	Nut Flange Lock Top	152	532 43 51-11	Manual Clutch Cable
19	585 32 39-01	Bearing Mandrel	--	587 25 33-01	Mandrel Assembly (Includes Hous- ing (key # 33), Shaft Assembly (key # 34), And Bearing (key #19) Only - Pulley/Nut/Washer And Blade Bolt/ Washers Not Included)
20	532 17 39-84	Screw Thd Roll Dod Pt Hex	--	532 43 15-50	Replacement Mower Complete
21	532 41 69-10	Keeper Belt Mandrel 30"			
22	532 17 58-20	Pulley Idler Flat			
23	817 49 06-28	Screw Thdrol 3/8 - 16 X 1-3/4			
24	819 13 20-12	Washer 13/32 X 1 - 1/4 X 12 Ga			
25	532 42 02-53	Keeper Belt 30"Srd			
26	532 42 02-55	Cover Mandrel Mwr 30"Black			
27	532 41 92-71	V-Belt Drive			
29	532 42 08-95	Hinge Pin			
32	532 40 18-72	Spring Return Deck 38/46"			
33	532 18 72-81	Housing Mandrel 4pt Service			

NOTE: All component dimensions given in U.S. inches
1 inch = 25.4 mm

TRACTOR - MODEL NO. M115-77TC (96051005801), PRODUCT NO. 960 51 00-58
MOWER LIFT 45

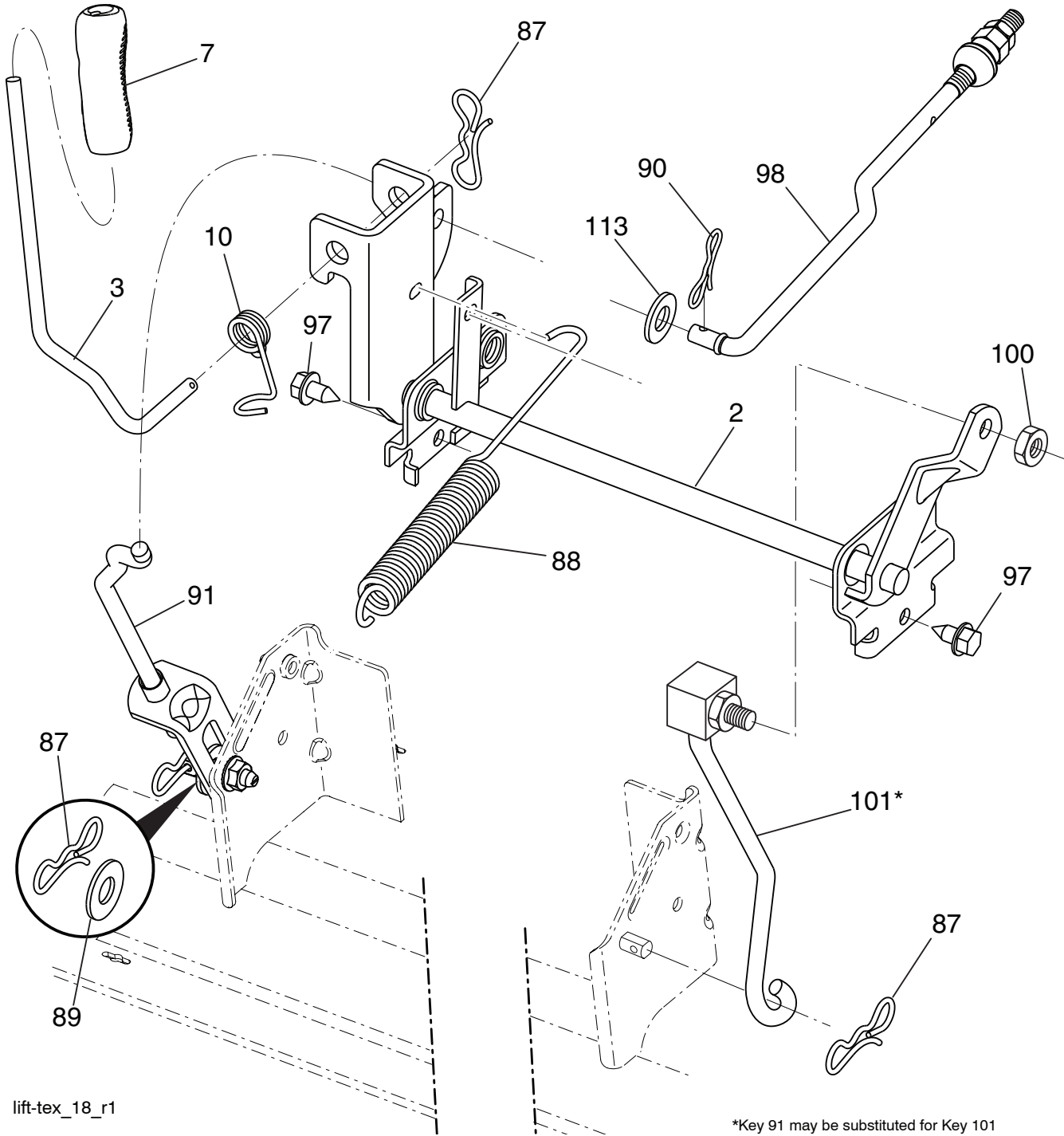

lift-tex_18_r1

*Key 91 may be substituted for Key 101

KEY NO.	PART NO.	DESCRIPTION
2	532 42 20-27	Shaft Asm. Cross, Lift
3	532 19 52-31	Lever Asm., Lift RH
7	580 96 23-01	Grip, Lever
10	532 19 63-14	Spring Torsion
87	532 19 42-09	Pin Cotter 7/16 Bow Tie Lock
88	532 41 07-10	Spring Lift Assist
89	819 19 19-12	Washer Clear
90	532 19 42-08	Pin Cotter 5/16 Bow Tie Lock
91	532 19 51-81	Link Asm Lift LH Rear

KEY NO.	PART NO.	DESCRIPTION
97	817 00 06-12	Screw Hex Wsh. THDR 3/8-16 x 3/4
98	532 19 52-64	Link Lift Susp. Front Mower
100	873 93 06-00	Nut Centerlock 3/8-16 unc
101	532 40 70-03	Link Asm. Lift Fixed
113	819 17 19-12	Washer Clear Zinc

NOTE: All component dimensions given in U.S. inches
 1 inch = 25.4 mm

**TRACTOR - MODEL NO. M115-77TC (96051005801), PRODUCT NO. 960 51 00-58
SEAT ASSEMBLY 42**

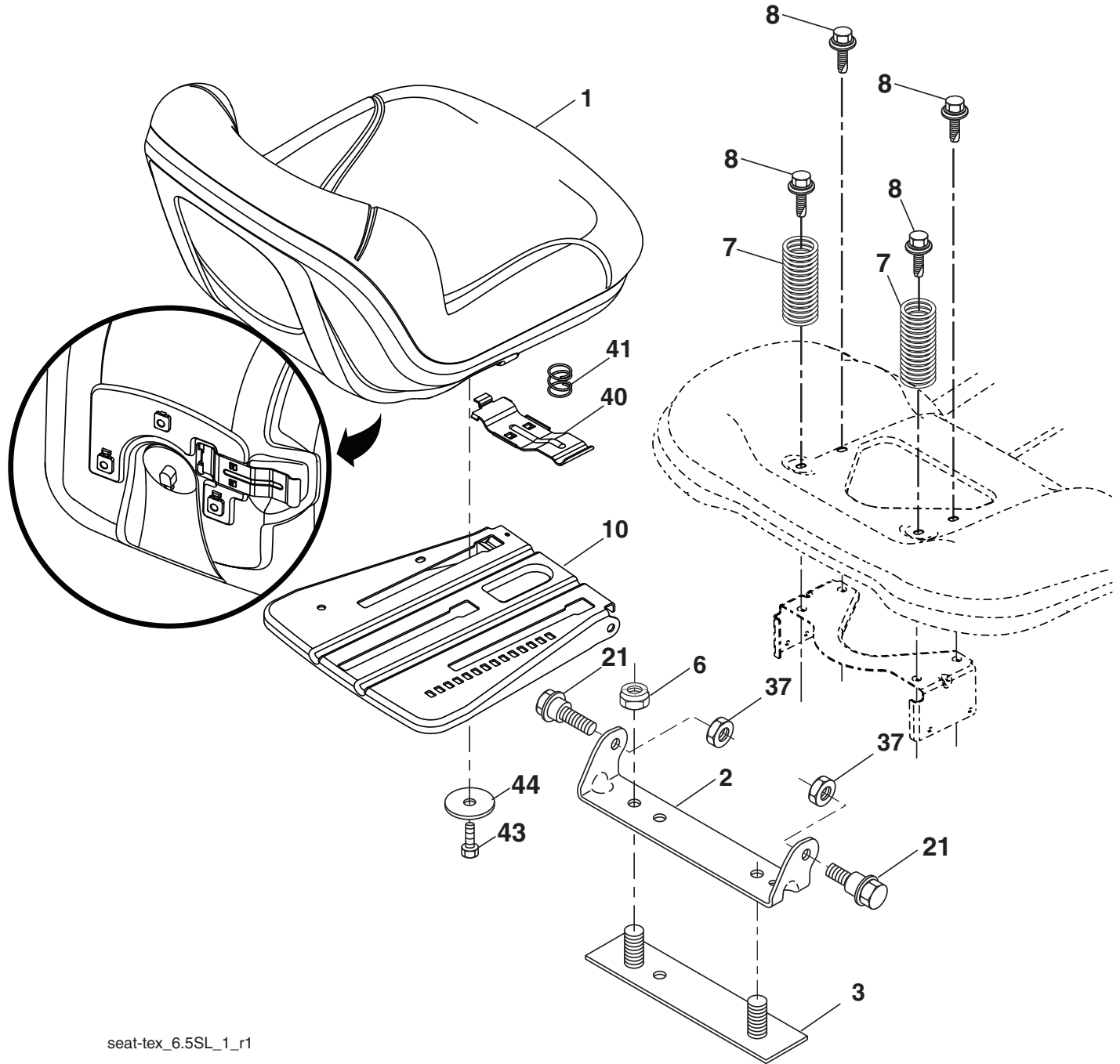

seat-tex_6.5SL_1_r1

KEY NO.	PART NO.	DESCRIPTION
1	581 46 20-01	Seat
2	532 18 01-66	Bracket Pivot Fender
3	532 14 06-75	Strap, Asm Fender
6	873 80 06-00	Nut, Lock w/Ins. 3/8-16 unc
7	532 12 41-81	Spring, Seat Cprsn
8	532 17 18-77	Bolt 5/16-18 unc x 3/4 w/Sems
10	532 19 69-77	Pan, Seat
21	532 17 18-52	Bolt, Shoulder 5/16-18

KEY NO.	PART NO.	DESCRIPTION
37	873 80 05-00	Nut, Lock 5/16-18 unc
40	532 19 76-61	Handle Slide Seat
41	532 19 82-00	Spring Latch Seat
43	874 76 06-12	Bolt Fin Hex 3/8-16 unc x 3/4
44	819 13 38-12	Washer 13/32 x 2-3/8 x 12 Ga.

NOTE: All component dimensions given in U.S. inches
1 inch = 25.4 mm

TRACTOR - MODEL NO. M115-77TC (96051005801), PRODUCT NO. 960 51 00-58
BAGGER **46**

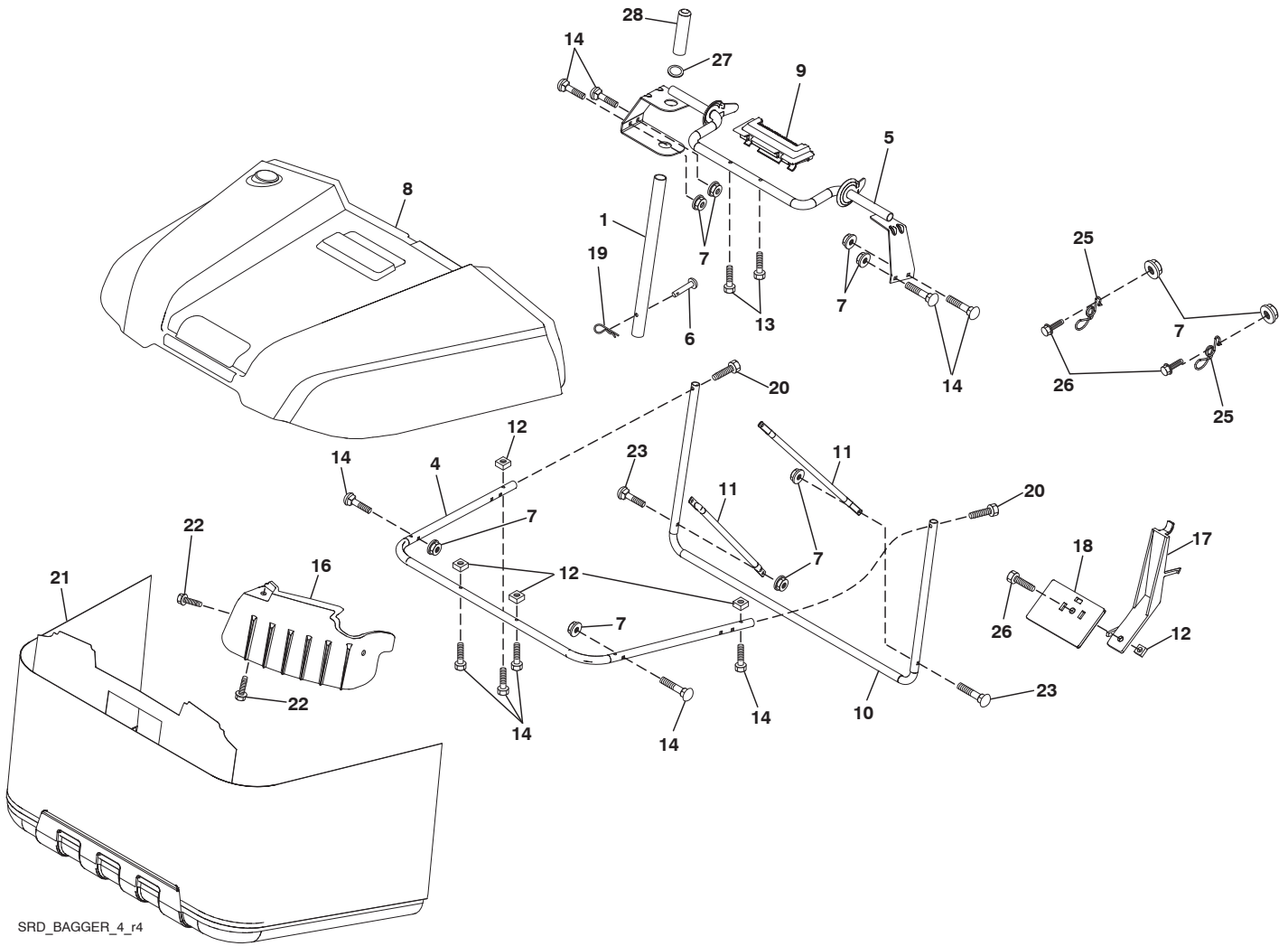

SRD_BAGGER_4_r4

**TRACTOR - MODEL NO. M115-77TC (96051005801), PRODUCT NO. 960 51 00-58
BAGGER 46**

KEY NO.	PART NO.	DESCRIPTION
1	532 42 86-10	Tube Handle Bagger SRD
4	532 43 96-12	Frame Asm Bagger Top
5	532 41 76-32	Frame Asm Top Bagger SRD
6	532 12 68-75	Drilled Rivit
7	873 90 04-00	Nut Hex Flange 1/4-20 unc
8	532 42 59-54	Cover Bagger SRD
9	532 41 76-29	Insert Handle Bagger
10	532 41 71-90	Frame Front
11	532 41 71-88	Tubing Brace Bagger
12	532 42 17-93	Nut Square 1/4
13	532 42 17-80	Screw 1/4 x 1.150 HXWSH
14	532 42 18-00	Bolt Shoulder HX WSH 1/4 x 1.150
16	532 42 15-66	Deflector Bagger
17	532 42 17-49	Lever Bagger Full
18	532 42 17-50	Paddle Bagger Full
19	532 19 42-08	Pin Cotter
20	585 36 88-01	Screw Hex Cap 1/4-20 x 1.375
21	581 33 69-01	Bag Asm SRD
22	532 14 24-32	Screw Hex WSH Hi-Lo 1/4 - 1/2 unc
23	872 04 04-10	Bolt Carr 1/4-20 unc x 1-1/4
25	532 42 16-14	Spring Latch Bagger
26	817 49 04-12	Screw Hex Thdrol 1/4-20 x 3/4
27	532 42 12-62	Grommet, Rubber SRD
28	532 16 57-87	Grip Handle Black

NOTE: All component dimensions given in U.S. inches
1 inch = 25.4 mm

