

# Repair Parts Manual Manual De Repuestos

M22-46T / 96042014600



English/Spanish



Please read the operator's manual carefully and make sure you understand the instructions before using the machine.

Por favor lea cuidadosamente y comprenda estas intrucciones antes de usar esta maquina.

# HOW TO USE THIS MANUAL

This manual is designed to provide the customer with a means to identify the parts on his/her tractor when ordering repair parts. The illustrations may or may not represent the actual assemblies; therefore, it is not recommended to use this manual as a guide to assemble or disassemble the tractor. Some hardware and parts are drawn larger in order to more readily identify them.

Each tractor has its own model number.

The model number for your tractor can be found on the fender under the seat.

When ordering parts, always give the following information:

- Product - "TRACTOR"
- MODEL NUMBER - "M22-46T" (96042014600)"
- Part Number
- Part Description

## TABLE OF CONTENTS

SCHEMATIC .....	3
ELECTRICAL.....	4-5
CHASSIS .....	6-7
DRIVE.....	8-9
ENGINE.....	10-11
STEERING .....	12-13
MOWER DECK.....	14-15
MOWER LIFT.....	16
SEAT .....	17
DECALS.....	18

## COMO UTILIZAR ESTE MANUAL

Este manual está diseñado para brindarle al comprador un medio para identificar las piezas del tractor para cuando necesite hacer el pedido de un repuesto. Las ilustraciones pueden o no representar los ensambles reales; por lo tanto, no se recomienda utilizar este manual como una guía para ensamblar o desarmar el tractor. Algunos accesorios y piezas están dibujados en tamaños más grandes para identificarlos con mayor facilidad.

Cada tractor tiene su propio número de modelo.

El número de modelo del tractor se encuentra en el guardabarros debajo del asiento.

Cuando haga el pedido de una pieza, siempre brinde la siguiente información:

- Producto: "TRACTOR"
- NÚMERO DE MODELO: "M22-46T" (96042014600)"
- Número de pieza
- Descripción de la pieza

## ÍNDICE

DIAGRAMA.....	19
DIAGRAMA ELÉCTRICO .....	20-21
CHASIS.....	22-23
TRANSMISIÓN .....	24-25
MOTOR .....	26-27
DIRECCIÓN .....	28-29
PLATAFORMA DE LA CORTADORA DE CÉSPED.....	30-31
ELEVACIÓN DE LA CORTADORA DE CÉSPED.....	32
ASIENTO.....	33
CALCOMANÍAS.....	34

# TRACTOR - - MODEL NO. M22-46T (96042014600), PRODUCT NO. 960 42 01-46 SCHEMATIC

SCH11

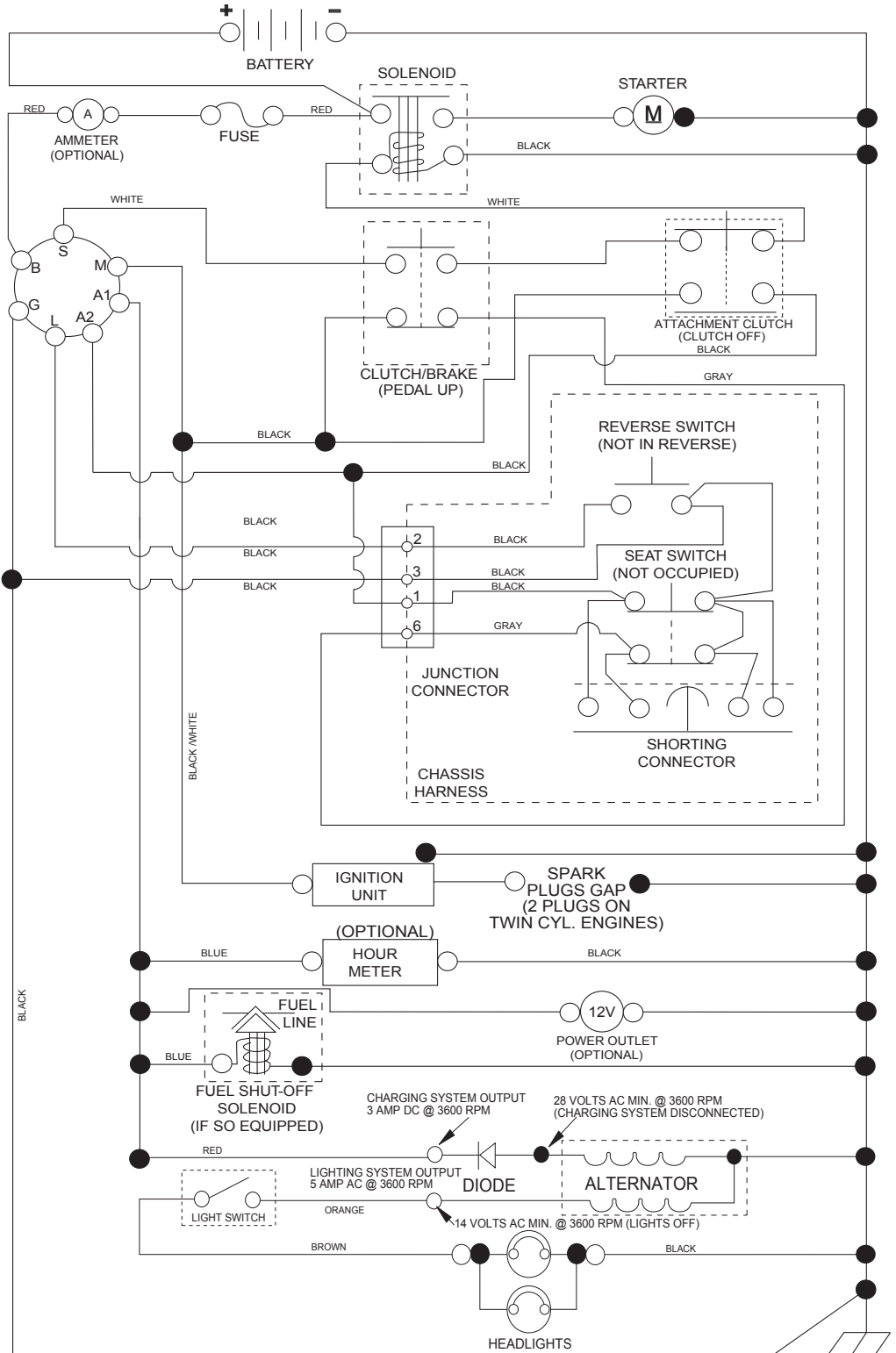

**NOTE**  
YOUR TRACTOR IS EQUIPPED WITH A SPECIAL ALTERNATOR SYSTEM. THE LIGHTS ARE NOT CONNECTED TO THE BATTERY, BUT HAVE THEIR OWN ELECTRICAL SOURCE. BECAUSE OF THIS, THE BRIGHTNESS OF THE LIGHTS WILL CHANGE WITH ENGINE SPEED. AT IDLE THE LIGHTS WILL DIM. AS THE ENGINE IS SPEEDED UP, THE LIGHTS WILL BECOME THEIR BRIGHTEST.

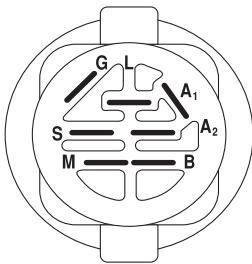

IGNITION SWITCH

POSITION	CIRCUIT	"MAKE"
OFF	M+G+A1	
RUN/OVERRIDE	B+A1	
RUN	B+A1	L+A2
START	B + S + A1	

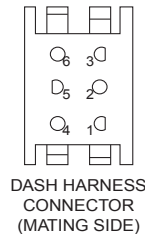
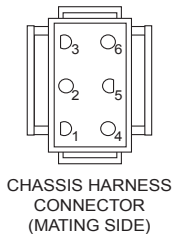

WIRING INSULATED CLIPS  
NOTE: IF WIRING INSULATED CLIPS WERE REMOVED FOR SERVICING OF UNIT, THEY SHOULD BE RE-INSTALLED TO PROPERLY SECURE YOUR WIRING.

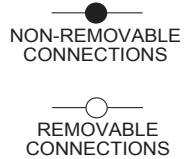

**TRACTOR - - MODEL NO. M22-46T (96042014600), PRODUCT NO. 960 42 01-46  
ELECTRICAL**

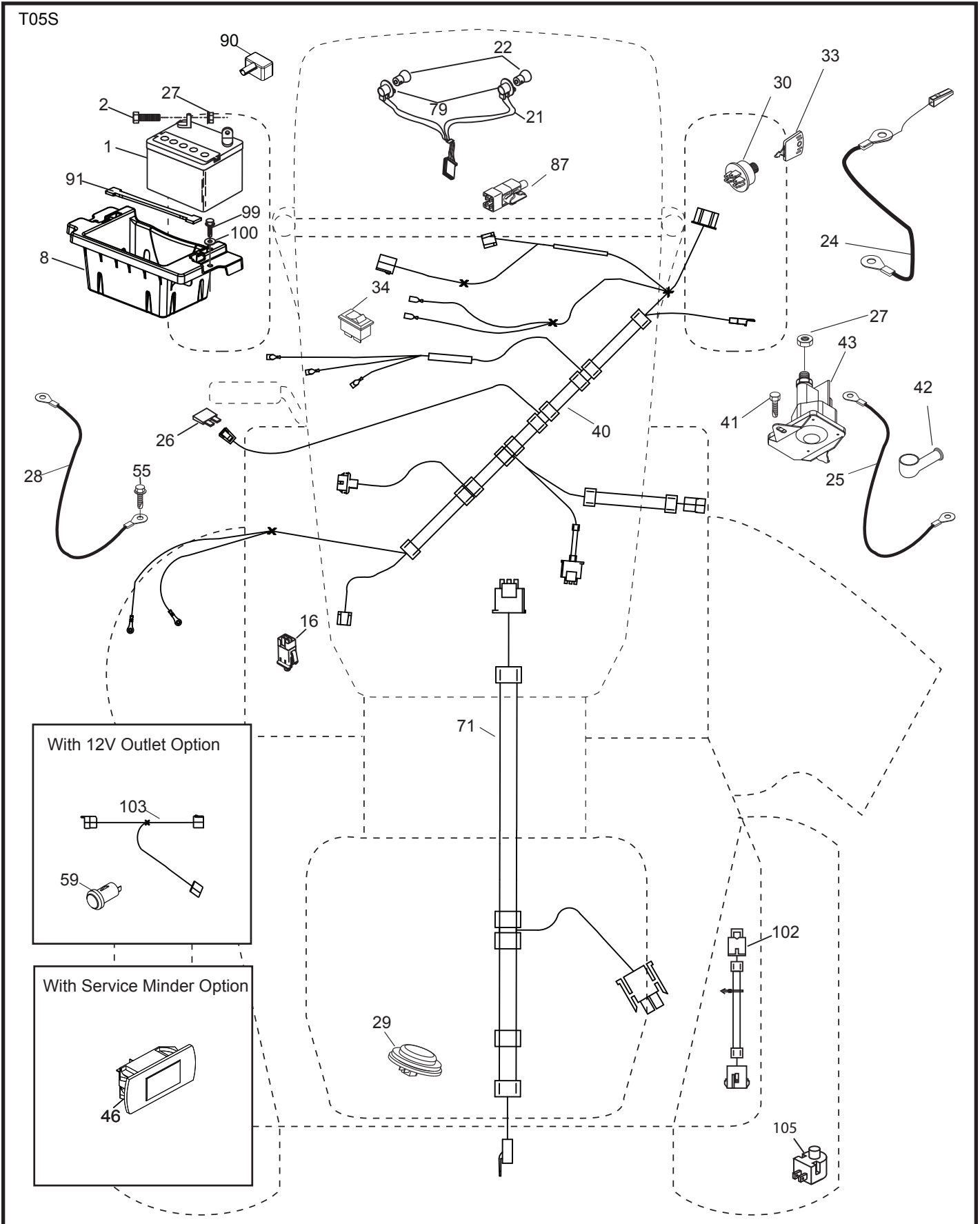

**TRACTOR - - MODEL NO. M22-46T (96042014600), PRODUCT NO. 960 42 01-46  
ELECTRICAL**

<b>KEY NO.</b>	<b>PART NO.</b>	<b>DESCRIPTION</b>
1	532 16 34-65	Battery
2	874 76 04-12	Bolt Hex Hd. 1/4-20 unc x 3/4
8	532 18 64-91	Box Battery
16	532 17 61-38	Switch Interlock Push-In
21	532 40 02-52	Harness Socket Light w/4152J
22	532 00 41-52	Bulb Light
24	532 40 02-53	Cable Battery
25	532 41 28-95	Cable Starter
26	532 17 51-58	Fuse
27	873 51 04-00	Nut Keps Hex 1/4-20 unc
28	532 14 54-91	Cable, Ground
29	532 40 15-45	Switch, Seat
30	532 19 33-50	Switch, Ign.
33	532 41 19-33	Key/Chain
34	532 11 07-12	Switch Light/Reset
40	532 40 10-98	Harness Ign. Dash
41	817 72 04-08	Screw Thd. Cut 1/4-20 x 1/2
42	532 13 15-63	Cover, Terminal
43	532 19 25-07	Solenoid
46	532 40 17-63	Gauge Hourmeter
55	817 06 05-12	Screw Thdrol. 5/16-18 x 3/4 TYTT
71	532 19 42-76	Harness Ign. Chassis
79	532 17 52-42	Bulbholder Asm. Incandescent
87	532 19 78-02	Switch Interlock Clutch
90	532 43 53-95	Cover Terminal Battery
91	532 19 02-70	Strap Battery
99	817 67 04-12	Screw 1/4-20 x 3/4
100	819 09 14-16	Washer 9/32 x 7/8 x 16 Ga.
102	581 02 34-01	Harness Pigtail
105	532 40 75-68	Switch Reverse

**NOTE:** All component dimensions given in U.S. inches  
1 inch = 25.4 mm

**TRACTOR - - MODEL NO. M22-46T (96042014600), PRODUCT NO. 960 42 01-46  
CHASSIS AND ENCLOSURES**

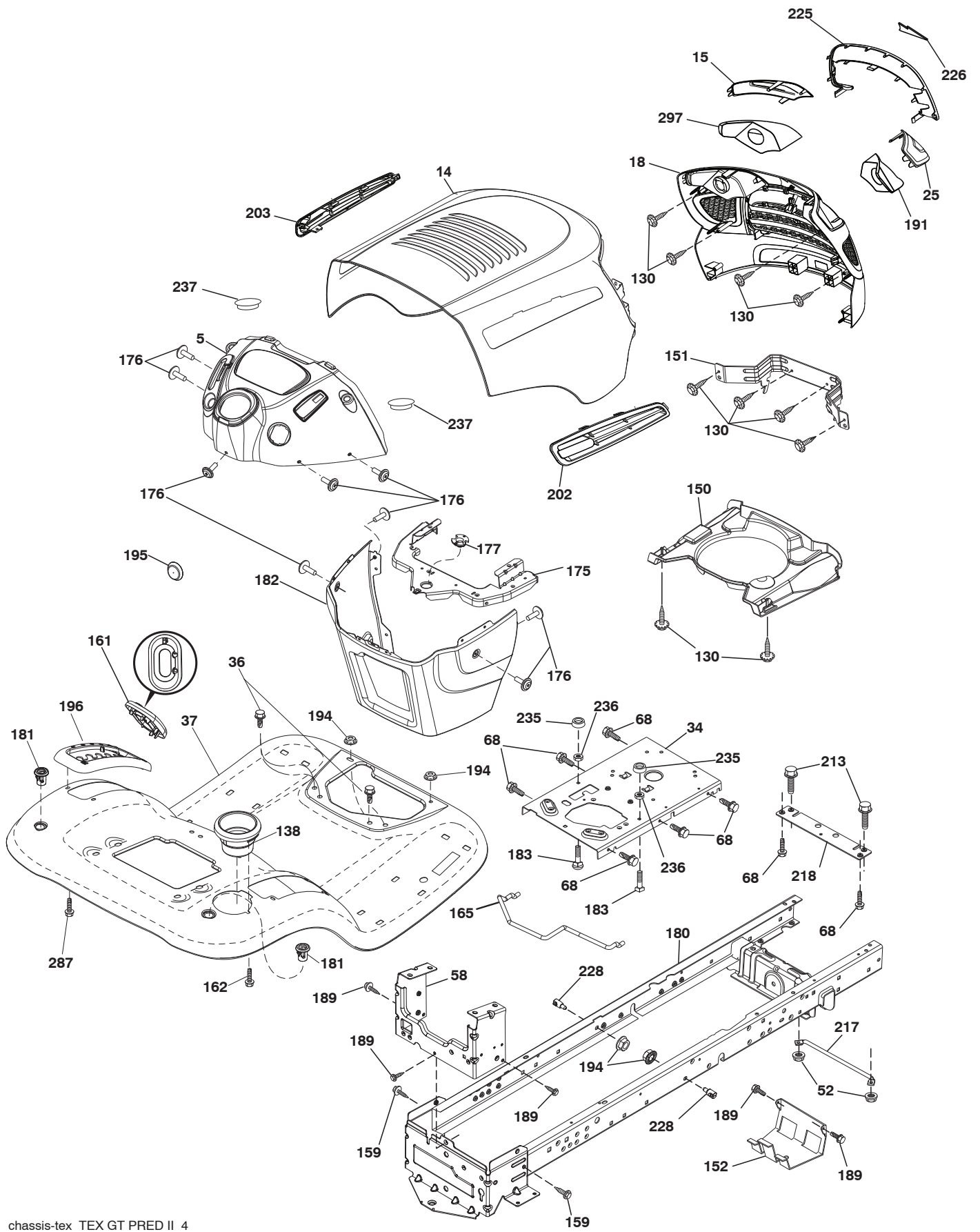

**TRACTOR - - MODEL NO. M22-46T (96042014600), PRODUCT NO. 960 42 01-46  
CHASSIS AND ENCLOSURES**

<b>KEY NO.</b>	<b>PART NO.</b>	<b>DESCRIPTION</b>
5	532 44 18-82	Dash
14	532 44 80-42	Hood
15	581 10 31-01	Lens LH
18	581 10 29-01	Grille
25	581 10 30-01	Lens RH
34	580 91 08-01	Plate Engine
36	817 06 05-12	Screw 5/16-18 x 3/4
37	583 93 97-01	Fender
52	873 68 05-00	Nut lock 5/16-18
58	532 41 22-80	Drawbar, Upper 2 Pc.
68	817 49 05-08	Screw Thdrol. 5/16-18 x 1/2
130	532 41 63-58	Screw #10 x 0.750
138	532 40 97-30	Cupholder
150	532 19 94-11	Duct Heat Hood
151	532 44 54-94	Bracket Pivot
152	532 19 95-35	Shield Browning
159	817 00 06-12	Screw Hex Wsh. Thdrol. 3/8-16 x 3/4
161	532 41 20-72	Window Fuel
162	532 14 24-32	Screw Hex Wsh. Hi-Lo 1/4 x 1/2
165	532 19 68-26	Support Tank
175	532 19 63-04	Crossmember
176	532 40 07-76	Screw 10-24 x 5/8 Wshd. Qdrx.
177	532 19 52-27	Bushing Steering
180	532 41 50-63	Chassis
181	532 40 47-96	Bushing Mtg. Fender Crgo.
182	532 40 68-59	Dash Lower
183	874 52 05-20	Bolt 5/16-18 x 1-1/4
189	817 00 05-12	Screw 5/16-18 x 3/4
191	581 22 35-01	Reflector RH
194	873 90 05-00	Nut Lock Hex Flange 5/16-18
195	532 40 41-37	Plug Hole Dash
196	532 41 45-79	Console Asm. Deck Lift
202	581 85 91-01	Vent Hood RH
203	581 85 92-01	Vent Hood LH
213	874 76 05-12	Bolt Hex Hd. 5/16-18 unc x 3/4
217	532 40 91-67	Rod Pivot Chassis
218	532 19 63-95	X-Piece Hood Stop
225	581 10 32-01	Trim Ring
226	578 89 71-01	Emblem Mount
228	532 19 51-61	Stud Fastener
235	532 40 61-29	Spacer Fender
236	873 93 05-00	Nut center Lock 5/16-18
237	532 40 37-04	Plug Mount Cargo
287	817 60 04-06	Screw 1/4-20 x 3/8
297	581 22 36-01	Reflector LH

**NOTE:** All component dimensions given in U.S. inches  
1 inch = 25.4 mm

TRACTOR - - MODEL NO. M22-46T (96042014600), PRODUCT NO. 960 42 01-46  
DRIVE

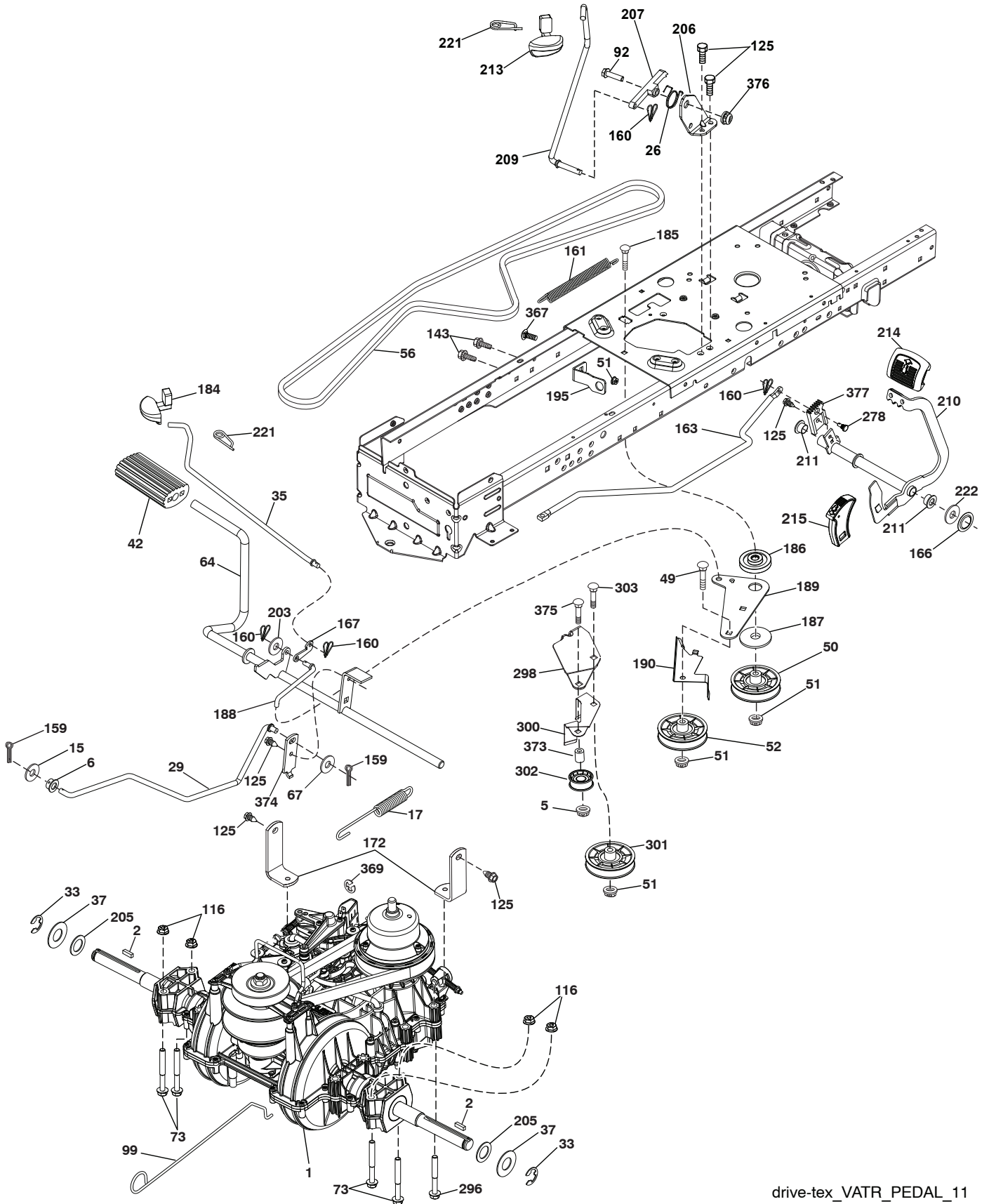

drive-tex\_VATR\_PEDAL\_11



# TRACTOR - - MODEL NO. M22-46T (96042014600), PRODUCT NO. 960 42 01-46 DRIVE

KEY PART NO.	NO.	DESCRIPTION	KEY PART NO.	NO.	DESCRIPTION
1	---	Transmission, Variator SD Pdeal (580486201) (Order parts from transaxle manufacturer.)	188	532 19 43-23	Link Clutch Ground Drive
2	532 12 35-83	Key Square	189	532 19 43-17	Bellcrank Grounddrive Nstg/Nstl
5	873 68 06-00	Nut Crownlock 3/8-16 unc	190	532 19 43-18	Keeper Bellcrank Drive Ground
6	532 12 40-28	Bushing Snap	195	581 50 46-01	Brake Bracket
15	819 13 13-16	Washer 13/32 x 13/16 x 16 Ga.	203	819 11 11-16	Washer 11/32 x 11/16 x 16 Ga.
17	532 41 36-78	Spring Brake	205	532 12 17-48	Washer 25/32 x 1-5/8 x 16 Ga.
26	532 44 82-66	Spring Return Cruise	206	532 44 85-96	Bracket Mount Latch Cruise
29	581 47 93-01	Rod Brake	207	532 44 82-64	Latch Control Cruise
33	812 00 00-01	E-Ring	209	532 19 95-92	Rod Control Cruise
35	532 43 54-86	Rod Brake Parking	210	532 44 82-70	Weldment Pedal
37	532 18 89-67	Washer Harden .793 x 1.637 x 060	211	532 12 01-83	Bearing Nylon
42	532 12 48-72	Cover Pedal Blk Round	213	532 40 31-19	Knob Control Cruise
49	872 11 06-14	Bolt Rdhd 3/8-16unc x1-3/4 Gr.5	214	532 42 12-63	Pedal Forward Pad
50	532 19 43-27	Idler.Flat	215	532 44 82-54	Cap Pedal Reverse
51	873 90 06-00	Nut Hex Flangelock 3/8-16	221	532 40 31-87	Retainer Spring Clip Handle
52	532 19 43-26	Idler V-Groove Offset	222	879 21 20-10	Washer 21/32 x 1-1/4 10 Ga.
56	532 19 72-53	Belt Drive	278	580 36 91-01	Bolt Cruise Variator
64	532 44 83-53	Shaft Asm. Pedal Brake	296	532 42 04-71	Screw Thdrol 5/16-18 x 3
67	819 13 13-12	Washer 13/32 x 13/16 x 12 Ga.	298	532 41 56-83	Bracket Mount Idler
73	874 49 05-44	Bolt Hex Flghd 5/16-18 Gr. 5	300	532 41 56-81	Keeper Idler Rear
92	874 76 05-20	Bolt	301	532 41 56-80	Pulley Idler V-Groove
99	532 43 59-35	Rod Bypass	302	581 42 05-01	Pulley Idler Flat 2.0 Od
116	873 90 05-00	Nut Lock Hex Flange 5/16-18 unc	303	872 11 06-18	Bolt Rdhd Sgnk 3/8-16 x 2-1/4
125	817 00 05-12	Screw 5/16-18 x 3/4 Smgml Tap/Bl	367	872 11 06-08	Bolt Rdhd Sgnk 3/8-16 x 1 Gr. 5
143	817 49 05-08	Screw Thdrol 5/16-18 x 1/2 Tytt	369	581 57 74-01	Clip E Variator
159	876 02 04-12	Pin Cotter 1/8 x 3/4	373	581 46 18-01	Spacer Idler
160	532 16 94-84	Retainer Clip(M) Dia. 290	374	581 47 52-01	Bracket Brake Arm
161	532 10 57-09	Spring Return Clutch 6.75	375	874 76 06-36	Bolt Hex HS 3/8-16 unc
163	532 44 82-68	Rod Control Pedal	376	532 42 68-59	Nut Flange
166	532 42 91-64	Nut Push .625	377	532 44 82-65	Gear Sector
167	532 40 52-57	Latch Brake Parking			
172	532 41 56-64	Strap Torque LH/RH			
184	532 44 14-55	Handle Parking Brake			
185	872 11 06-22	Bolt Rdhd 3/8-16 unc x 2-3/4 Gr.5			
186	532 19 43-21	Spacer Retainer			
187	819 13 32-10	Washer 13/32 x 2 x 10 Ga.			

**NOTE:** All component dimensions given in U.S. inches  
1 inch = 25.4 mm

TRACTOR - - MODEL NO. M22-46T (96042014600), PRODUCT NO. 960 42 01-46  
ENGINE

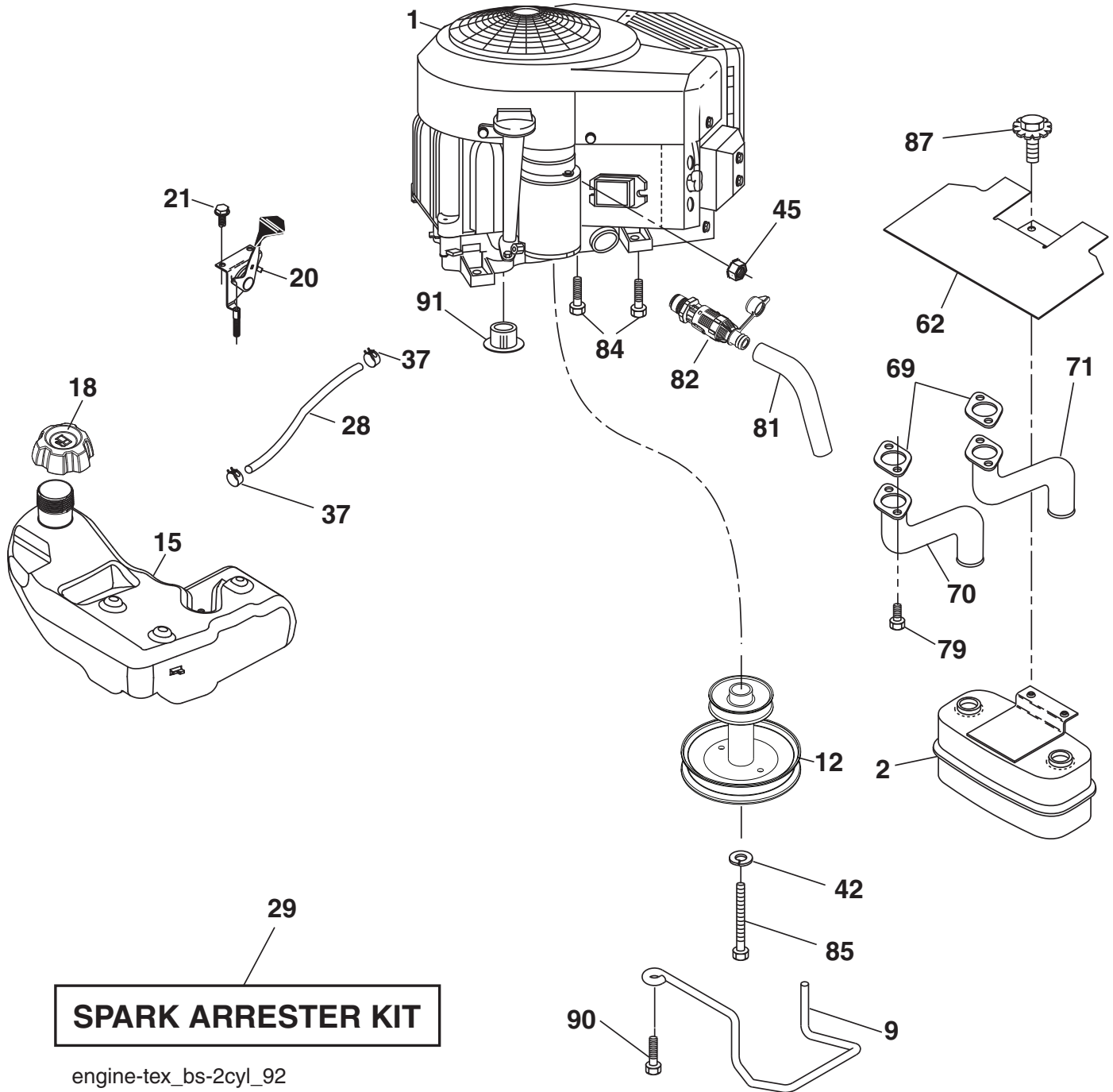

# TRACTOR - - MODEL NO. M22-46T (96042014600), PRODUCT NO. 960 42 01-46 ENGINE

KEY PART NO.	PART NO.	DESCRIPTION
1	---	Engine B&S Model No. 407777-3195-G5 (581081901)(Order parts from engine manufacturer.)
2	532 14 97-23	Muffler
9	532 19 43-19	Keeper Belt Engine
12	532 40 51-40	Pulley Engine
15	532 43 80-80	Tank Fuel
18	532 43 02-14	Cap Fuel
20	532 42 35-02	Control Throttle/Choke
21	532 41 63-58	Screw #10 x 0.750
28	532 13 70-40	Fuel Line
29	532 13 71-80	Spark Arrester Kit
37	532 12 34-87	Clamp Hose
42	810 04 07-00	Washer Lock 7/16
45	873 51 04-00	Nut Keps Hex 1/4-20 unc
62	532 43 40-17	Shield Heat Muffler
69	532 16 53-91	Gasket
70	532 15 99-55	Exhaust Tube LH
71	532 16 05-89	Exhaust Tube RH
79	532 18 39-06	Screw Socket Hd 5/16-18 x 1
81	532 14 84-56	Tube Drain Oil
82	532 42 82-87	Valve Oil Drain
84	817 06 06-20	Screw 3/8-16 x 1-1/4
85	532 17 39-37	Bolt Hex 7/16-20 x 4 x Gr. 5-1.5
87	532 17 18-77	Bolt 5/16-18 unc x 3/4 w/Sems
90	817 00 06-16	Screw 3/8-16 x 1
91	532 18 74-95	Bushing

**NOTE:** All component dimensions given in U.S. inches  
1 inch = 25.4 mm

For engine service and replacement parts, call the toll free number for your engine manufacturer listed below:

Briggs & Stratton      1-800-233-3723

## Engine Power Rating Information

The gross power rating for individual gas engine models is labeled in accordance with SAE (Society of Automotive Engineers) code J1940 (Small Engine Power & Torque Rating Procedure), and rating performance has been obtained and corrected in accordance with SAE J1995 (Revision 2002-05). Torque values are derived at 3060 RPM; horsepower values are derived at 3600 RPM. Actual gross engine power will be lower and is affected by, among other things, ambient operating conditions and engine-to-engine variability. Given both the wide array of products on which engines are placed and the variety of environmental issues applicable to operating the equipment, the gas engine will not develop the rated gross power when used in a given piece of power equipment (actual "on-site" or net power). This difference is due to a variety of factors including, but not limited to, accessories (air cleaner, exhaust, charging, cooling, carburetor, fuel pump, etc.), application limitations, ambient operating conditions (temperature, humidity, altitude), and engine-to-engine variability. Due to manufacturing and capacity limitations, Briggs & Stratton may substitute an engine of higher rated power for this Series engine.

**TRACTOR - - MODEL NO. M22-46T (96042014600), PRODUCT NO. 960 42 01-46**  
**STEERING ASSEMBLY**

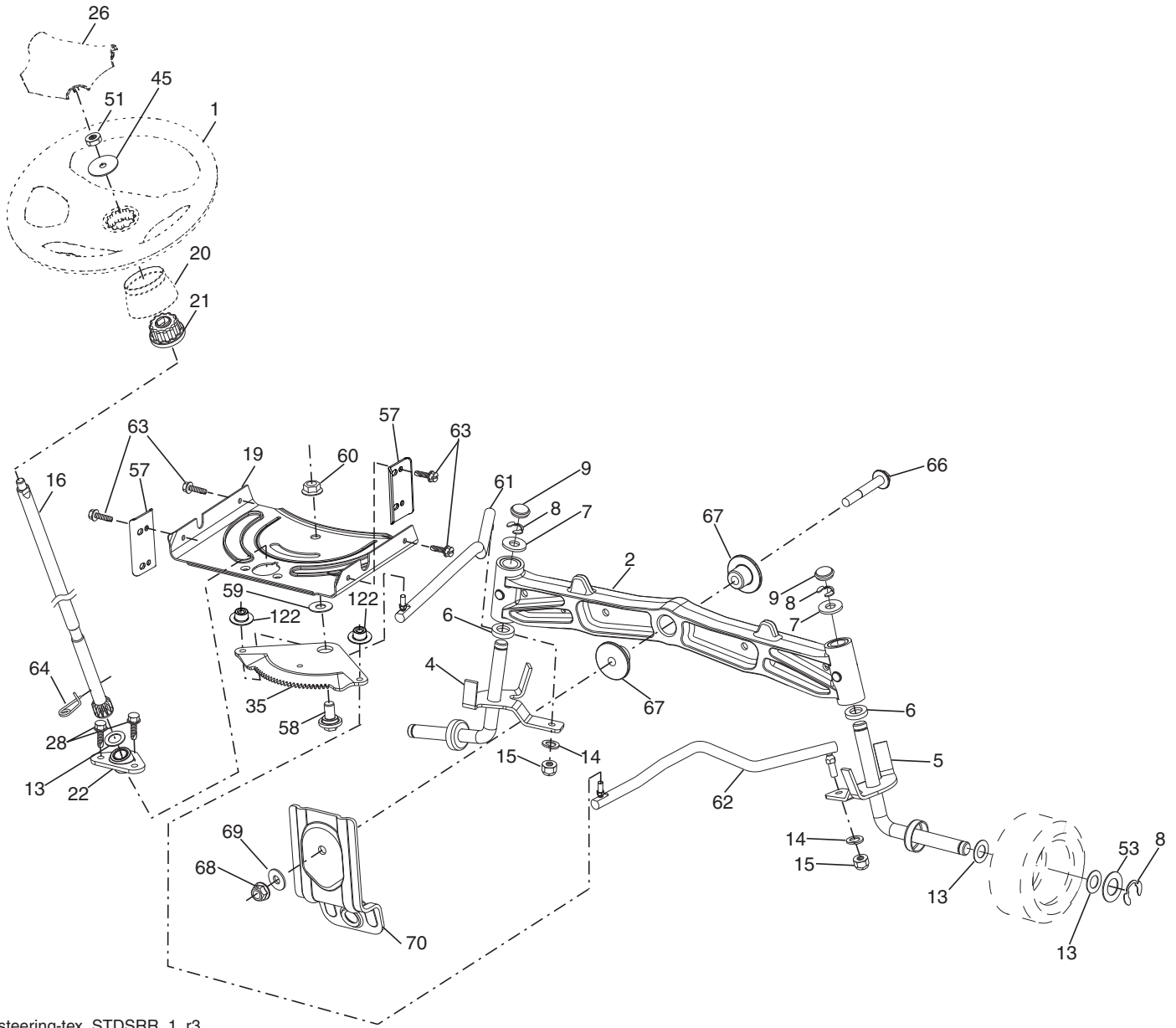

steering-tex\_STDSRR\_1\_r3

**TRACTOR - - MODEL NO. M22-46T (96042014600), PRODUCT NO. 960 42 01-46  
STEERING ASSEMBLY**

<b>KEY NO.</b>	<b>PART NO.</b>	<b>DESCRIPTION</b>
1	532 44 28-04	Wheel, Steering
2	532 19 59-68	Axle Asm., Front
4	532 40 30-87	Spindle Asm., LH
5	532 40 30-88	Spindle Asm., RH
6	532 12 49-31	Bearing, Race Thrust Harden
7	532 12 17-48	Washer 25/32 x 1-5/8 x 16 Ga.
8	812 00 00-29	Ring, Clip #T5304-75
9	532 12 12-32	Cap, Spindle
13	532 12 17-49	Washer 25/32 x 1-1/4 x 16 Ga.
14	810 04 06-00	Washer, Lock Hvy. Hlcl. Spr. 3/8
15	873 54 06-00	Nut, Crown Lock 3/8-24 unf
16	532 40 82-19	Shaft Steering
19	532 19 47-29	Plate Steering
20	532 42 47-40	Boot, Steering
21	532 18 67-37	Adapter, Wheel Steering
22	532 42 05-37	Steering Support Lower
26	532 44 77-59	Insert, Wheel Steering
28	817 00 06-12	Screw 3/8-16 x 3/4
35	532 19 47-32	Gear, Sector Plate
45	819 18 38-12	Washer 9/16 x 2-3/8 x 12 Ga.
51	873 94 08-00	Nut Hex Jam Toplock 1/2-20 unf
53	532 18 89-67	Washer Hardened .793 x 1.637 x .060
57	532 40 74-65	Bracket Upstop
58	532 19 47-47	Bolt Shoulder Sector Pivot CFM
59	532 19 47-48	Washer Thrust Sector Steering
60	873 97 10-00	Nut Flange Lock 5/8-11
61	532 19 47-40	Draglink LH
62	532 19 47-41	Draglink, RH
63	817 00 05-12	Screw 5/16-18 x 3/4
64	532 19 98-49	Retainer Clip Spring Steering
66	871 02 07-48	Bolt Hex Fghd. 7/16-14 x 3 Serr.
67	532 19 47-37	Bushing PM Front Axle
68	873 90 07-00	Nut Lock Flange 7/16-14 Gr. 5
69	532 19 91-62	Washer 1.5 x .505 x .118
70	532 19 61-97	Bracket Deck Susp. Front
122	532 44 49-62	Cap Gear Sector

**NOTE:** All component dimensions given in U.S. inches  
1 inch = 25.4 mm

**TRACTOR - - MODEL NO. M22-46T (96042014600), PRODUCT NO. 960 42 01-46**  
**MOWER DECK**

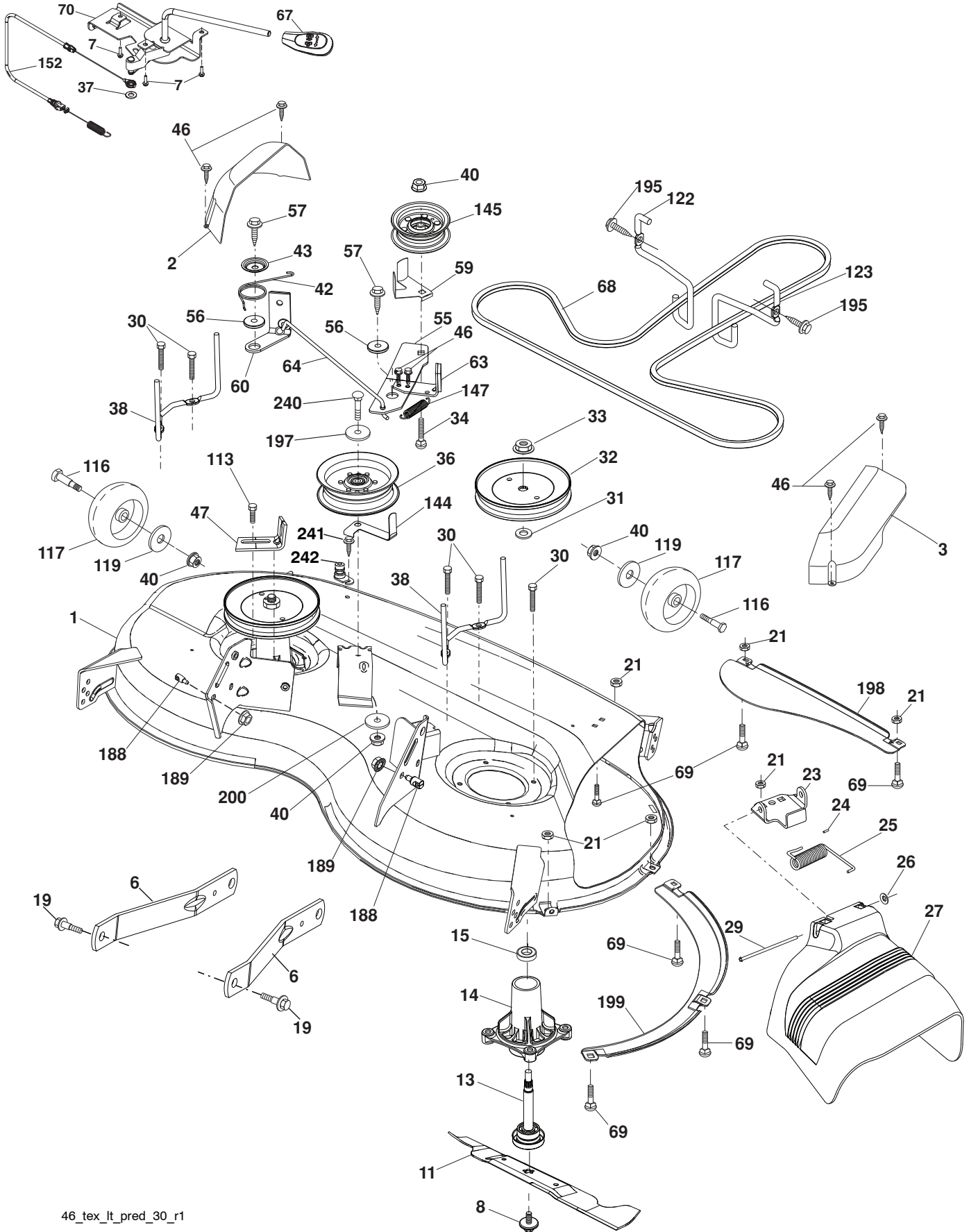

46\_tex\_lt\_pred\_30\_r1

**TRACTOR - - MODEL NO. M22-46T (96042014600), PRODUCT NO. 960 42 01-46  
MOWER DECK**

<b>KEY NO.</b>	<b>PART NO.</b>	<b>DESCRIPTION</b>	<b>KEY NO.</b>	<b>PART NO.</b>	<b>DESCRIPTION</b>
1	532 44 16-11	Mower Housing	67	532 40 30-12	Handle Clutch Cable
2	532 40 55-07	Cover Mandrel LH	68	532 40 51-43	Belt, Drive
3	532 40 55-06	Cover Mandrel RH	69	872 14 05-05	Bolt
6	532 19 51-86	Arm Suspension	70	532 19 99-72	Clutch Asm. Manual
7	532 41 63-58	Screw #10 x 0.750	113	817 00 05-10	Bolt 5/16-18
8	532 19 30-03	Bolt/Washer Asm 7/16-20 unf	116	532 12 48-42	Bolt, Shoulder
11	532 40 53-80	Blade	117	532 18 86-06	Wheel, Gauge
13	532 19 28-72	Shaft Assembly, Mandrel	119	819 12 14-14	Washer 3/8 x 7/8 x 14 Ga.
14	532 18 72-81	Housing, Mandrel	122	532 19 72-58	Keeper Belt Engine LH
15	532 11 04-85	Bearing, Ball, Mandrel	123	532 19 72-59	Keeper Belt Engine RH
19	532 19 65-39	Bolt, Shoulder	144	532 19 92-04	Keeper Belt Mower
21	873 68 05-00	Nut, Crownlock 5/16-18 unc	145	532 19 73-79	Pulley Idler
23	532 19 25-57	Bracket, Deflector	147	532 40 18-72	Spring Mower Deck
24	532 10 53-04	Cap, Sleeve	152	532 43 51-11	Cable Clutch Manual
25	532 19 70-26	Spring, Torsion, Deflector	188	532 19 51-61	Stud Fastener
26	532 11 04-52	Nut, Push	189	873 90 05-00	Nut Lock Hex Flange
27	532 40 53-57	Shield, Deflector	195	817 00 06-12	Screw 3/8-16 x 3/4
29	532 13 14-91	Rod, Hinge	197	819 13 13-12	Washer 13/32 x 13/16 x 12 Ga.
30	532 17 39-84	Screw Thdrol Rolling Wsh Hd	198	532 40 31-49	Baffle Center Front
31	532 18 76-90	Washer, Spacer	199	532 40 31-50	Baffle Front RH
32	532 19 74-73	Pulley, Mandrel	200	532 41 35-24	Washer 13/32 x 1 x 1/2 x 11 Ga.
33	532 40 02-34	Nut, Toplock, Flanged	240	874 52 06-36	Bolt Fin Hex 3/8-16 x 2-1/4 Gr. 5
34	872 11 06-12	Bolt Carr Sh. 3/8-16 x 1-1/2 Gr. 5	241	532 15 29-27	Screw #10-32.5 3/8 Flange
36	532 19 31-97	Pulley, Idler, Primary	242	532 41 55-98	Port Washout
37	819 13 13-16	Washer 13/32 x 13/16 x 16 Ga.	--	532 41 64-05	Coupling
38	532 43 25-20	Keeper Belt Mower	--	532 19 28-70	Mandrel Assembly (Includes housing (key# 14), shaft assembly (key# 13), bearing (key# 15) and nut (key# 33) only-pulley/washer and blade bolt/washer not included.)
40	873 90 06-00	Nut, Lock Flg. 3/8-16 unc			
42	532 19 84-10	Spring Torsion Brake			
43	532 19 72-56	Spring Torsion Retainer			
46	532 13 77-29	Screw 1/4-20 x 5/8			
47	532 19 72-50	Clutch Cable			
55	532 19 72-49	Arm, Idler	--	532 41 80-63	Replacement Mower, Complete
56	532 19 90-92	Spacer, Retainer			
57	817 00 06-16	Screw 3/8-16 x 1			
59	532 14 10-43	Guard, Tuv Idler			
60	532 19 94-71	Arm Brake Mower			
63	532 19 94-77	Arm Brake Mower			
64	532 40 51-38	Linkage Asm. Brake			

**NOTE:** All component dimensions given in U.S. inches  
1 inch = 25.4 mm

**TRACTOR - - MODEL NO. M22-46T (96042014600), PRODUCT NO. 960 42 01-46  
MOWER LIFT**

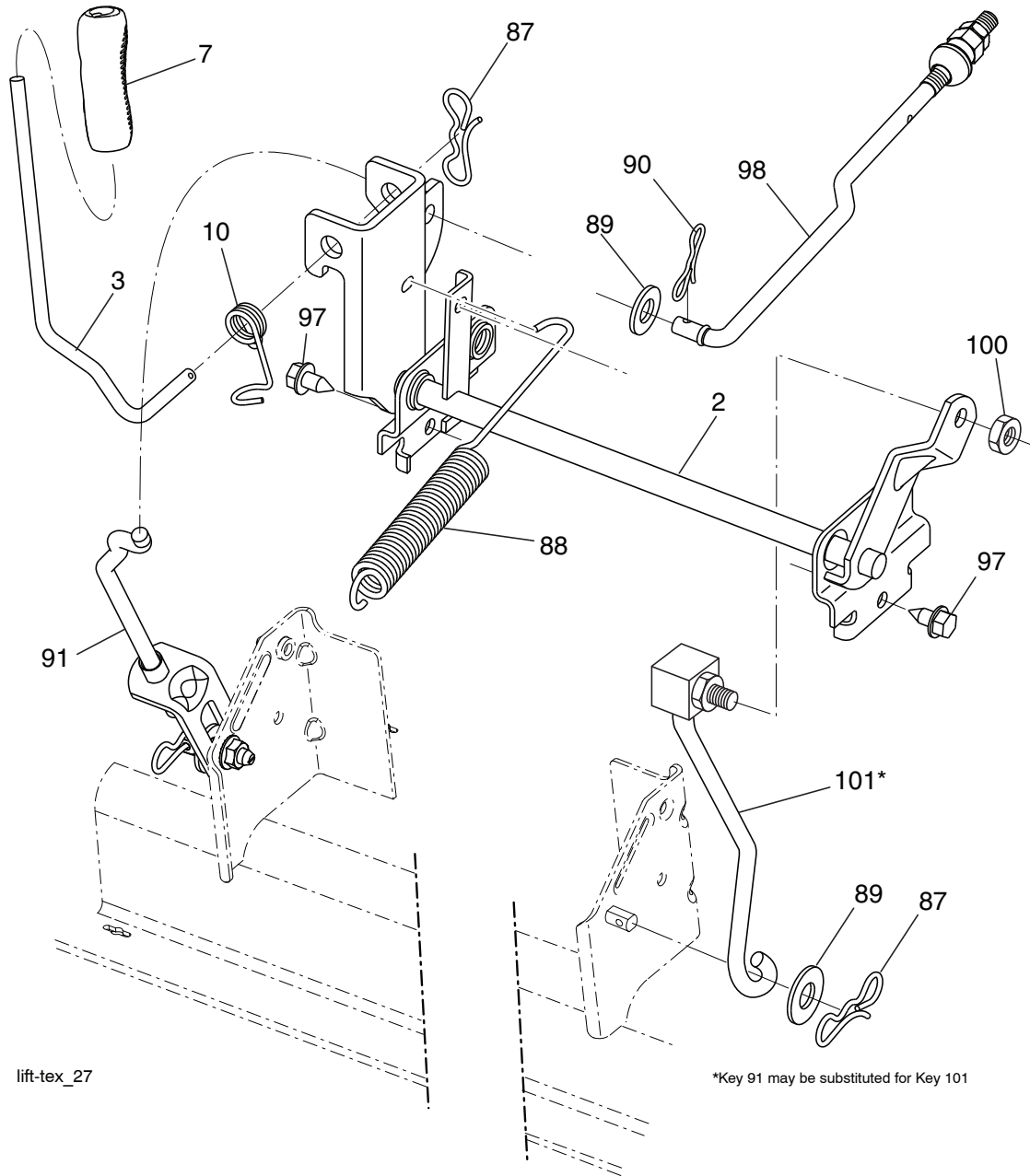

lift-tex\_27

\*Key 91 may be substituted for Key 101

KEY NO.	PART NO.	DESCRIPTION
2	532 42 20-27	Shaft Asm., Cross Lift
3	532 19 52-31	Lever Asm., Lift RH
7	580 96 23-01	Grip, Lever
10	532 19 63-14	Spring Torsion
87	532 19 42-09	Pin Cotter 7/16 Bow Tie Lock
88	532 41 07-10	Spring Lift Assist
89	819 19 19-12	Washer Clear Zinc
90	532 19 42-08	Pin Cotter 5/16 Bow Tie Lock

KEY NO.	PART NO.	DESCRIPTION
91	581 89 70-01	Link Lift Susp. Mower Rear
97	817 00 06-12	Screw 3/8-16 x 3/4
98	581 50 69-01	Link Lift Susp. Front Mower
100	873 93 06-00	Nut Centerlock 3/8-16 unc
101	532 89 71-01	Link Asm Lift Fixed

**NOTE:** All component dimensions given in U.S. inches  
1 inch = 25.4 mm



**TRACTOR - - MODEL NO. M22-46T (96042014600), PRODUCT NO. 960 42 01-46  
SEAT ASSEMBLY**

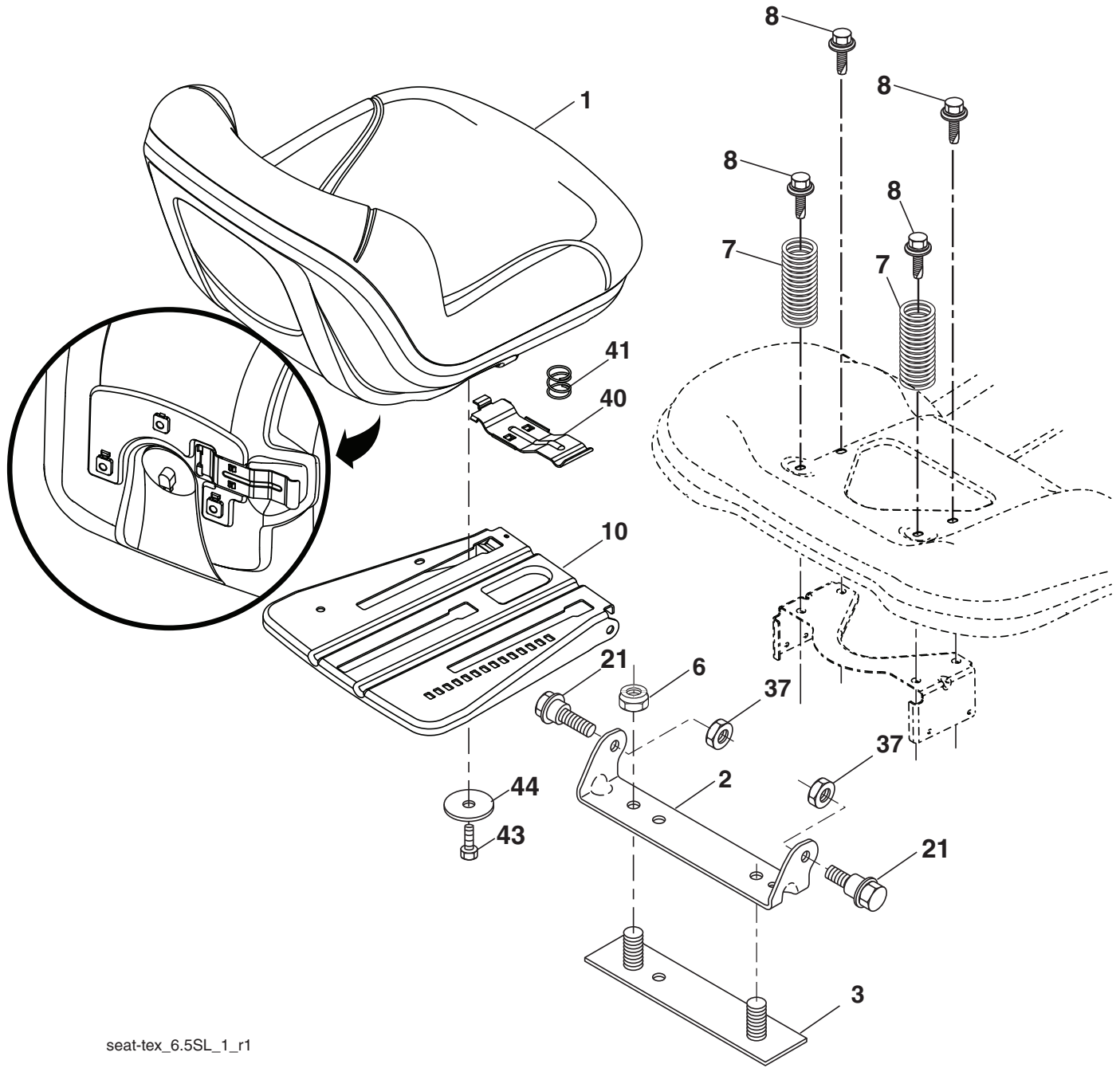

seat-tex\_6.5SL\_1\_r1

KEY NO.	PART NO.	DESCRIPTION
1	581 46 22-01	Seat
2	532 18 01-66	Bracket Pivot Fender
3	532 14 06-75	Strap, Asm Fender
6	873 80 06-00	Nut, Lock w/Ins. 3/8-16 unc
7	532 12 41-81	Spring, Seat Cprsn
8	532 17 18-77	Bolt 5/16-18 unc x 3/4 w/Sems
10	532 19 69-77	Pan, Seat
21	532 17 18-52	Bolt, Shoulder 5/16-18

KEY NO.	PART NO.	DESCRIPTION
37	873 80 05-00	Nut, Lock 5/16-18 unc
40	532 19 76-61	Handle Slide Seat
41	532 19 82-00	Spring Latch Seat
43	874 76 06-12	Bolt 3/8-16 x 3/4
44	819 13 38-12	Washer 13/32 x 2-3/8 x 12 Ga.

**NOTE:** All component dimensions given in U.S. inches  
1 inch = 25.4 mm

**TRACTOR - - MODEL NO. M22-46T (96042014600), PRODUCT NO. 960 42 01-46  
DECALS**

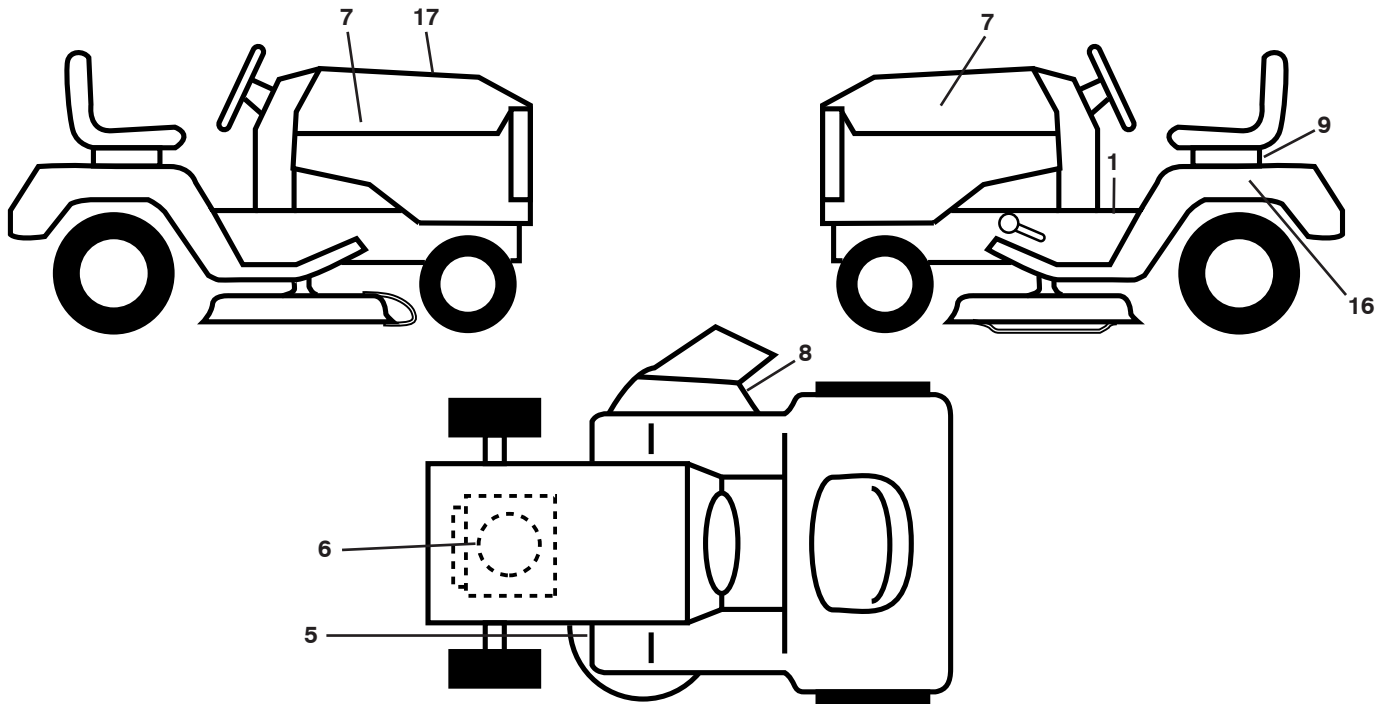

KEY NO.	PART NO.	DESCRIPTION
1	581 57 89-01	Decal, Read Manual
5	581 58 00-01	Decal, V-Belt Sch.
6	581 25 85-01	Decal, Eng. HP
7	581 09 12-01	Decal, Hood LH/RH
8	581 57 95-01	Decal, Cutfinger
9	532 14 50-05	Decal, Battery Dnge/Poi
16	581 98 08-01	Decal, Fender

KEY NO.	PART NO.	DESCRIPTION
17	581 59 33-01	Decal, Replacement
--	581 72 48-01	Decal, Bypass
--	532 40 95-05	Pad, Footrest, LH
--	532 40 95-07	Pad, Footpedal
--	115 56 35-27	Manual, Operator's Eng/Span
--	583 87 21-27	Manual, Parts Eng/Span

**WHEELS & TIRES**

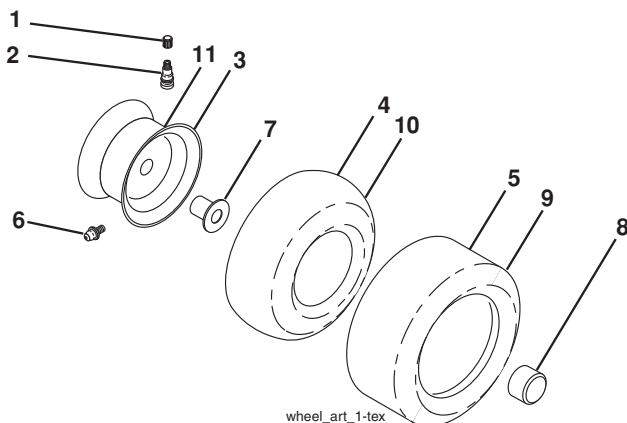

KEY NO.	PART NO.	DESCRIPTION
1	532 05 91-92	Cap, Valve, Tire
2	532 06 51-39	Stem, Valve
3	532 12 51-21	Rim Assembly, Front
4	532 05 99-04	Tube, Front
5	532 10 62-22	Tire, Front
6	532 12 49-57	Fitting, Grease
7	532 12 49-59	Bearing, Flange
8	532 19 32-68	Cap, Axle
9	532 13 84-68	Tire, Rear
10	532 12 49-26	Tube, Rear
11	532 12 51-22	Rim Assembly, Rear
--	532 14 43-34	Sealant, Tire (10 oz. Tube)

**NOTE:** All component dimensions given in U.S. inches  
1 inch = 25.4 mm

# TRACTOR MODELO NO. M22-46T (96042014600), PRODUCTO NO. 960 42 01-46 DIAGRAMA

SCH11-s

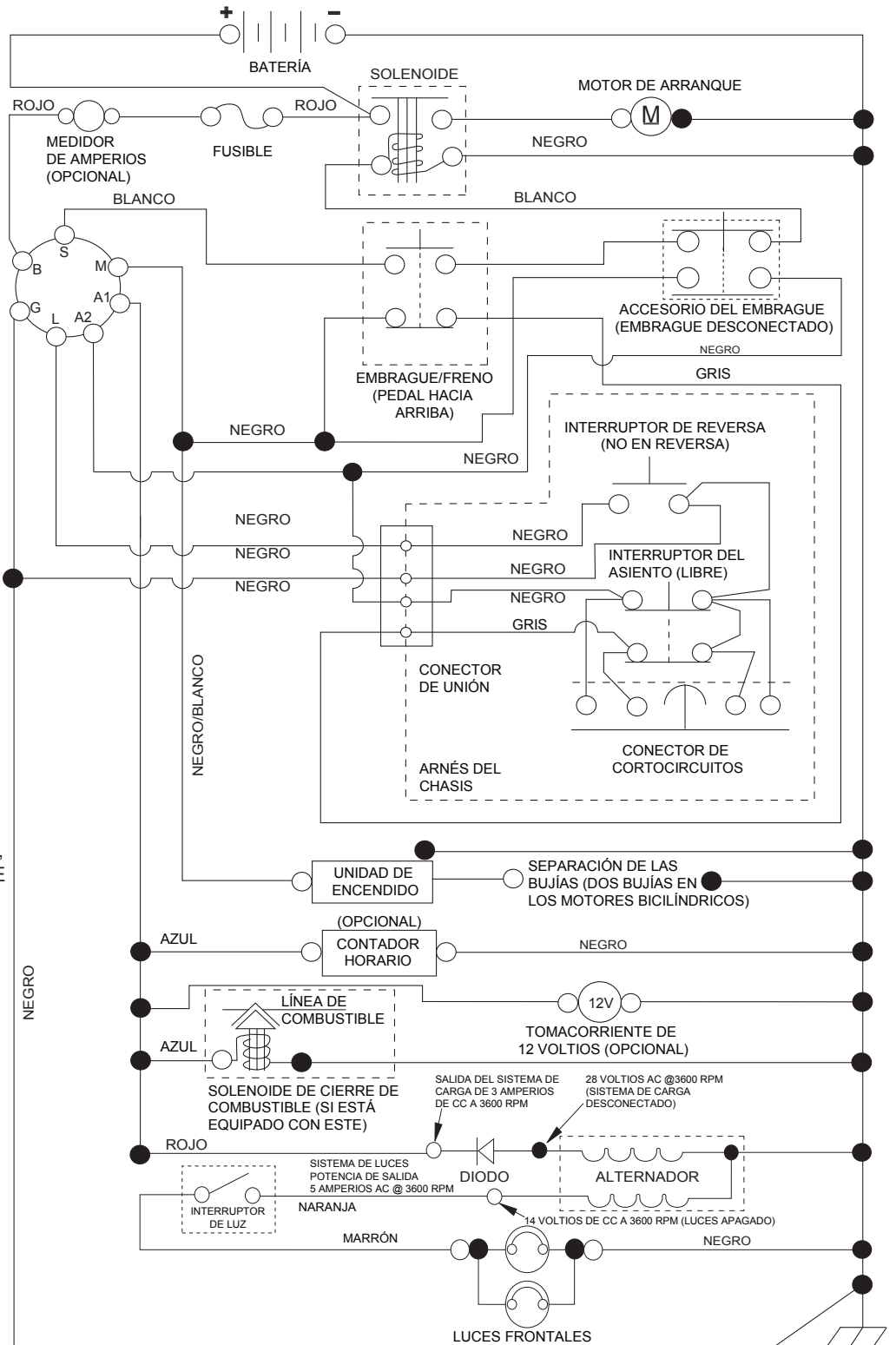

**NOTAS:**  
 QUE SU TRACTOR ES EQUIPADO CON UN SISTEMA ESPECIAL DE ALTERNADOR. LAS LUCES NO SON CONECTADAS A LA BATERIA, PERO TIENEN SU PROPIA FUENTE ELECTRICA. A CAUSA DE ESTO, EL BRILLO DE LAS LUCES CAMBIARA CON LA VELOCIDAD DE MOTOR. EN LENTO, LAS LUCES NO SON COMO BRILLANTES. CUANDO EL MOTOR ES ACELERADO, LA LUZ CONSEGUIRÁ MÁS BRILLANTE.

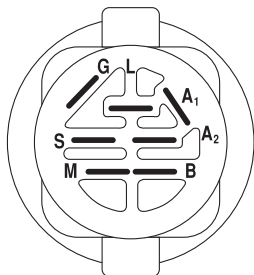

INTERRUPTOR DE ENCENDIDO

POSICIÓN	CIRCUITO «MARCA»
APAGADO	M+G+A1
PONER EN FUNCIONAMIENTO/ANULAR	B+A1
PONER EN FUNCIONAMIENTO	B+A1 L+A2
ARRANCAR	B + S + A1

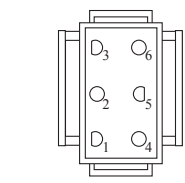

CONEXIÓN DEL ARNÉS DEL CHASIS (LATERAL QUE COINCIDA)

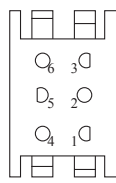

CONEXIÓN PARA EL ARNÉS DEL TABLERO (LATERAL QUE COINCIDA)

NOTA SOBRE LAS ABRAZADERAS DE AISLAMIENTO DEL CABLEADO: SI SE QUITAN LAS ABRAZADERAS DE AISLAMIENTO DEL CABLEADO PARA HACER EL MANTENIMIENTO DE LA UNIDAD, SE LAS DEBERÁ INSTALAR NUEVAMENTE PARA PROTEGER EL CABLEADO ADECUADAMENTE.

● CONEXIONES NO DESMONTABLES

○ CONEXIONES DESMONTABLES

**TRACTOR MODELO NO. M22-46T (96042014600), PRODUCTO NO. 960 42 01-46**  
**DIAGRAMA ELÉCTRICO**

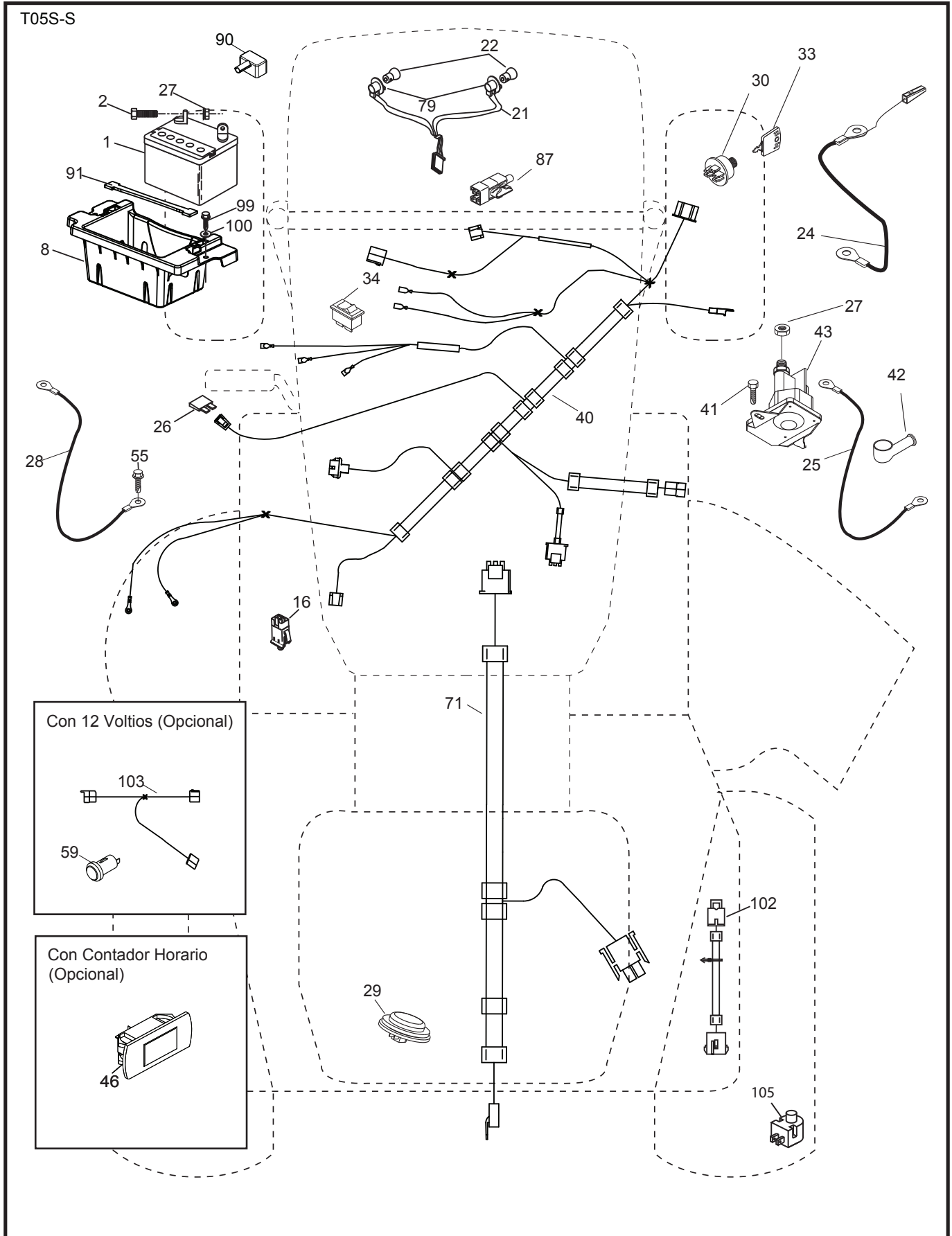

**TRACTOR MODELO NO. M22-46T (96042014600), PRODUCTO NO. 960 42 01-46  
DIAGRAMA ELÉCTRICO**

<b>CÓDIGO NO.</b>	<b>PIEZA NO.</b>	<b>DESCRIPCIÓN</b>
1	532 16 34-65	Batería
2	874 76 04-12	Perno de cabeza hexagonal de 1/4-20 x 3/4
8	532 18 64-91	Caja de la batería
16	532 17 61-38	Interruptor corta corriente a presión
21	532 40 02-52	Cableado del enchufe para la luz c/4152J
22	532 00 41-52	Bombilla de luz
24	532 40 02-53	Cable
25	532 41 28-95	Cable
26	532 17 51-58	Fusible
27	873 51 04-00	Tuerca hexagonal Keps de 1/4-20 unc
28	532 14 54-91	Cable a tierra
29	532 40 15-45	Interruptor del asiento
30	532 19 33-50	Interruptor de encendido
33	532 41 19-33	Llave/cadena
34	532 11 07-12	Interruptor de luz/de restauración
40	532 40 10-98	Cableado del tablero de encendido
41	817 72 04-08	Tornillo 1/4-20 x 1/2
42	532 13 15-63	Cubierta de la terminal
43	532 19 25-07	Solenoide
46	532 40 17-63	Indicador SRVCMNDR HRMTR
55	817 06 05-12	Tornillo 5/16-18 x 3/4
71	532 19 42-76	Cableado de encendido
79	532 17 52-42	Enchufe de cierre por torsión del ensamble de la bombilla
87	532 19 78-02	Interruptor corta corriente de embrague
90	532 43 53-95	Tapa de los bornes de la batería
91	532 19 02-70	Correa de la batería
99	817 67 04-12	Tornillo 1/4-20 x 3/4
100	819 09 14-16	Arandela de 9/32 x 7/8 x calibre 16
102	581 02 34-01	Cableado
105	532 40 75-68	Interruptor para retroceder

**NOTA:** Las dimensiones de todos los componentes están expresadas en pulgadas americanas. 1 pulgada = 25,4 mm

TRACTOR MODELO NO. M22-46T (96042014600), PRODUCTO NO. 960 42 01-46  
CHASIS

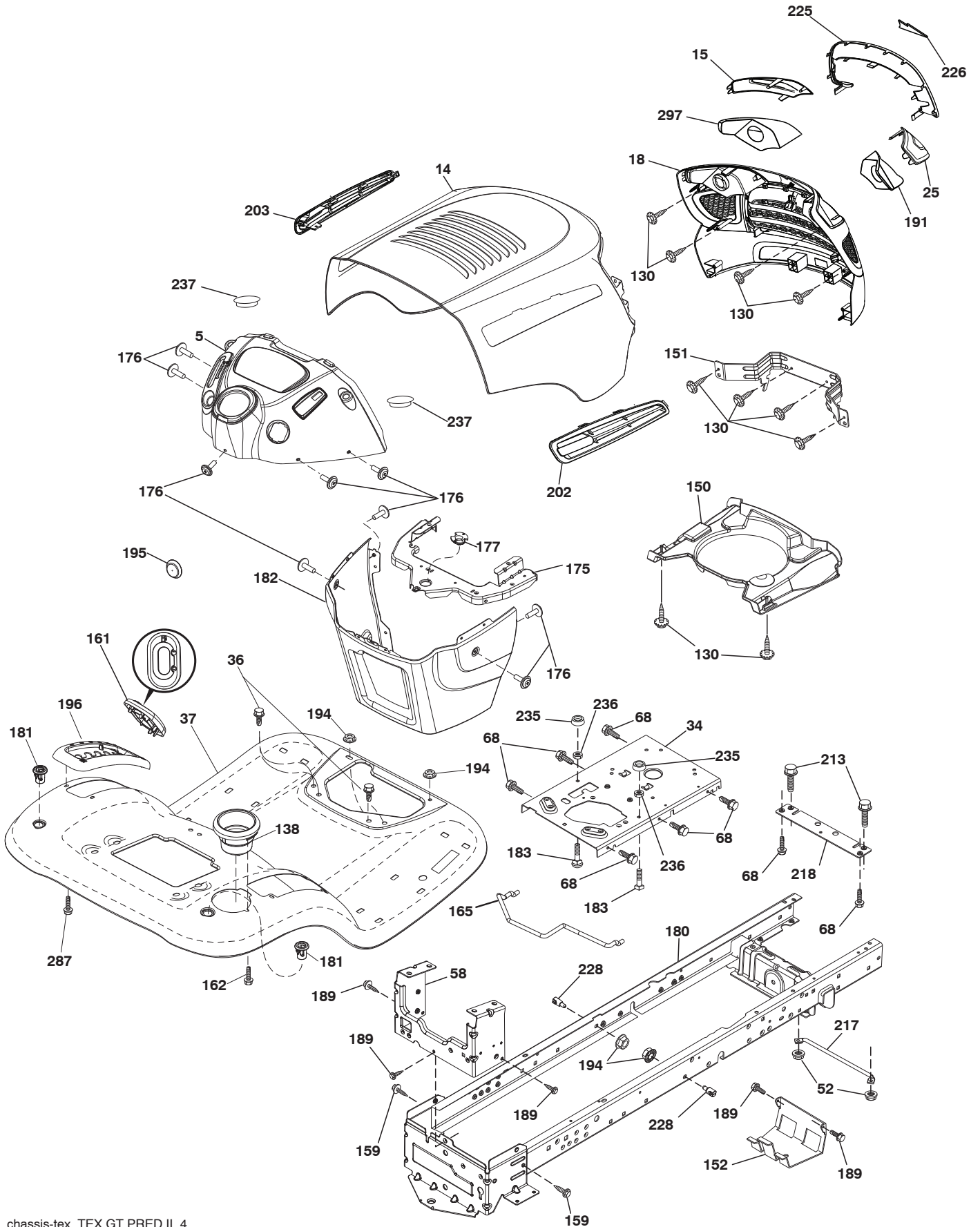

**TRACTOR MODELO NO. M22-46T (96042014600), PRODUCTO NO. 960 42 01-46  
CHASIS**

<b>CÓDIGO NO.</b>	<b>PIEZA NO.</b>	<b>DESCRIPCIÓN</b>
5	532 44 18-82	Tablero
14	532 44 80-42	Capota
15	581 10 31-01	Lente izquierdo de la parrilla
18	581 10 29-01	Parrilla
25	581 10 30-01	Lente derecho de la parrilla
34	580 91 08-01	Chapa Motor
36	817 06 05-12	Tornillo de 5/16-18 x 3/4
37	583 93 97-01	Guardabarros
52	873 68 05-00	Tuerca de presión 5/16-18
58	532 41 22-80	Barra de tracción, superior 2 pieza
68	817 49 05-08	Tornillo de 5/16-18 x 1/2
130	532 41 63-58	Tornillo de No.10 x 0.750
138	532 40 97-30	Portavasos
150	532 19 94-11	Cubierta térmica del conducto
151	532 44 54-94	Soporte
152	532 19 95-35	Protector contra oscurecimiento
159	817 00 06-12	Tornillo de 3/8-16 x 3/4
161	532 41 20-72	Abastecza de combustible ventana
162	532 14 24-32	Tornillo de 1/4 x 1/2
165	532 19 68-26	Soporte
175	532 19 63-04	Travesaño
176	532 40 07-76	Tornillo de 10-24 x 5/8
177	532 19 52-27	Buje de dirección
180	532 41 50-63	Chasis
181	532 40 47-96	Buje de soporte del guardabarros de carga
182	532 40 68-59	Tablero inferior
183	874 52 05-20	Perno 5/16-18 x 1-1/4
189	817 00 05-12	Tornillo de 5/16-18 x 3/4
191	581 22 35-01	Reflector (LD)
194	873 90 05-00	Tuerca de presión de 5/16-18
195	532 40 41-37	Tapón
196	532 41 45-79	Ensamble de la consola de la plataforma de elevación
202	581 85 91-01	Salida de Ventilación (LD)
203	581 85 92-01	Salida de Ventilación (LI)
213	874 76 05-12	Perno 5/16-18 unc x 3/4
217	532 40 91-67	Varilla giratoria Chasis
218	532 19 63-95	Tope
225	581 10 32-01	Guarnición
226	578 89 71-01	Símbolo de montaje
228	532 19 51-61	Sujetador del travesaño
235	532 40 61-29	Separador del guardabarros
236	873 93 05-00	Tuerca de presión 5/16-18
237	532 40 37-04	Tapón
287	817 60 04-06	Tornillo de 1/4-20 x 3/8
297	581 22 36-01	Reflector (LI)

**NOTA:** Las dimensiones de todos los componentes están expresadas en pulgadas americanas. 1 pulgada = 25,4 mm

TRACTOR MODELO NO. M22-46T (96042014600), PRODUCTO NO. 960 42 01-46  
TRANSMISIÓN

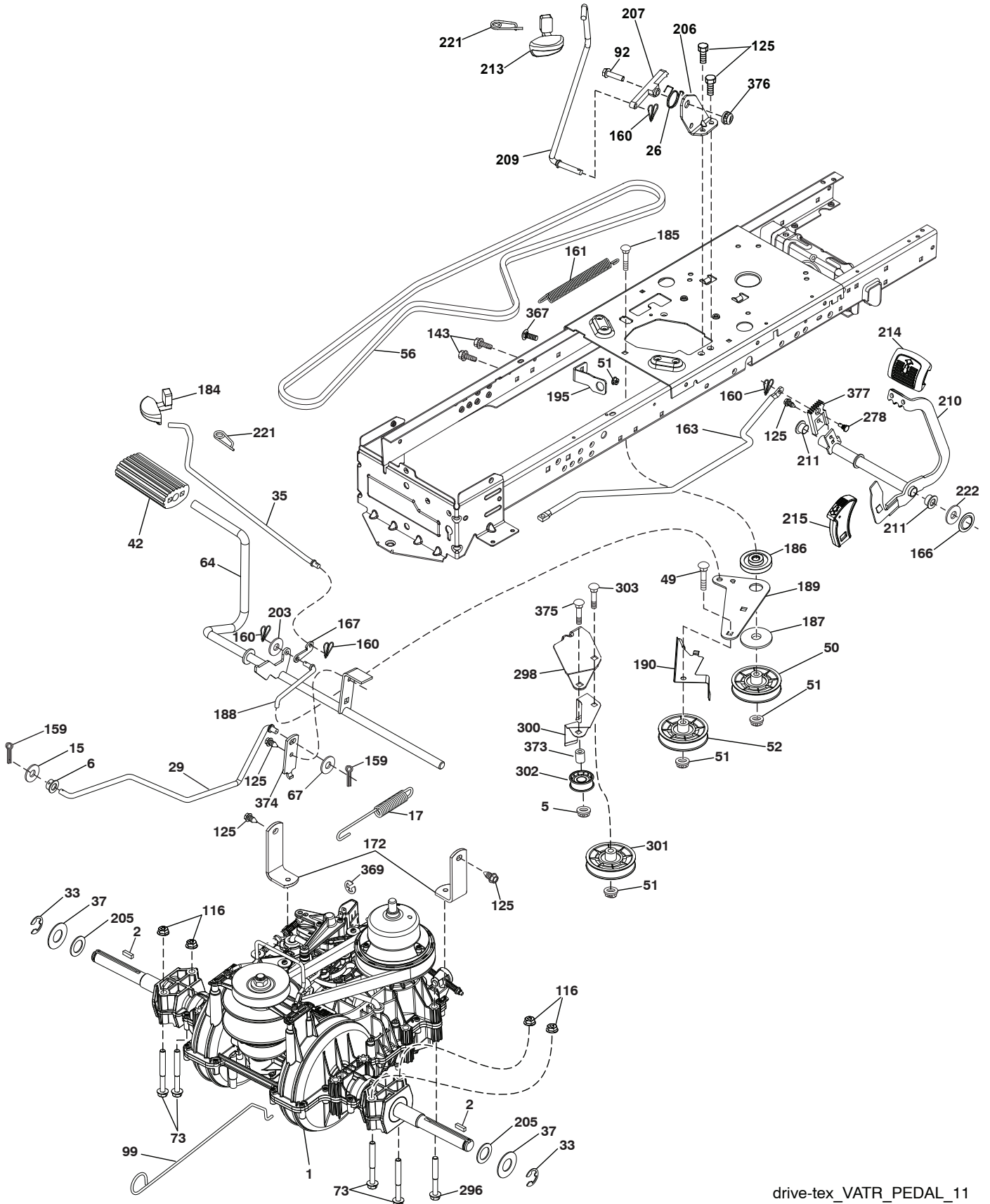

drive-tex\_VATR\_PEDAL\_11



**TRACTOR MODELO NO. M22-46T (96042014600), PRODUCTO NO. 960 42 01-46  
TRANSMISIÓN**

<b>CÓDIGO NO.</b>	<b>PIEZA NO.</b>	<b>DESCRIPCIÓN</b>	<b>CÓDIGO NO.</b>	<b>PIEZA NO.</b>	<b>DESCRIPCIÓN</b>
1	---	Transeje, Varitor SD Pedal (580486201) (Haga el pedido de las piezas al fabricante del transeje.)	189	532 19 43-17	Palanca acodada del mecanismo de desplazamiento
2	532 12 35-83	Cuña	190	532 19 43-18	Sujetador de la palanca acodada del mecanismo de desplazamiento
5	873 68 06-00	Tuerca 3/8-16 unc	195	581 50 46-01	Soporte del freno
6	532 12 40-28	Buje	203	819 11 11-16	Arandela de 11/32x11/16x calibre 16
15	819 13 13-16	Arandela de 13/32x13/16x calibre 16	205	532 12 17-48	Arandela de 25/32x1-5/8x calibre 16
17	532 41 36-78	Resorte de freno	206	532 44 85-96	Soporte de montaje del bloqueo del crucero
26	532 44 82-66	Crucero con retorno de muelle	207	532 44 82-64	Bloqueo del control del crucero
29	581 47 93-01	Varilla del freno	209	532 19 95-92	Varilla de control del crucero
33	812 00 00-01	Aro E	210	532 44 82-70	Ensamble del pedal
35	532 43 54-86	Varilla del freno de mano	211	532 12 01-83	Rodamiento de nylon
37	532 18 89-67	Arandela de .793 x 1.637 x 060	213	532 40 31-19	Perilla de control del crucero
42	532 12 48-72	Cubierta del pedal	214	532 42 12-63	Forro del pedal para avanzar
49	872 11 06-14	Perno de 3/8-16unc x1-3/4 grado 5	215	532 44 82-54	Forro del pedal para retroceder
50	532 19 43-27	Polea loca plana	221	532 40 31-87	Abrazadera de retención del resorte de la manija
51	873 90 06-00	Tuerca 3/8-16	222	879 21 20-10	Arandela de 21/32 x 1-1/4 calibre 10
52	532 19 43-26	Polea loca con ranura en V con un desplazamiento	278	580 36 91-01	Perno
56	532 19 72-53	Correa de la transmisión	296	532 42 04-71	Tornillo de 5/16-18 x 3
64	532 44 83-53	Ensamble del eje Control del pedal de freno	298	532 41 56-83	Soporte
67	819 13 13-12	Arandela de 13/32 x 13/16 x calibre 12	300	532 41 56-81	Polea loca Sujetador
73	874 49 05-44	Perno de 5/16-18 Gr. 5	301	532 41 56-80	Polea loca plana
92	874 76 05-20	Perno	302	581 42 05-01	Polea loca plana 2.0 Od
99	532 43 59-35	Varilla del con resorte de desviación	303	872 11 06-18	Perno
116	873 90 05-00	Tuerca 5/16-18 unc	367	872 11 06-08	Perno de 3/8-16 x 1 grado 5
125	817 00 05-12	Tornillo de 5/16-18 x 3/4	369	581 57 74-01	Cierre
143	817 49 05-08	Tornillo de 5/16-18 x 1/2 Tytt	373	581 46 18-01	Separador
159	876 02 04-12	Pasador de chaveta de 1/8 x 3/4	374	581 47 52-01	Soporte
160	532 16 94-84	Abrazadera de retención	375	874 76 06-36	Perno de HS 3/8-16 unc
161	532 10 57-09	Resorte de retorno del embrague 6.75	376	532 42 68-59	Tuerca
163	532 44 82-68	Varilla de control del pedal	377	532 44 82-65	Crucero con Engranaje del sector
166	532 42 91-64	Tuerca de presión .625			
167	532 40 52-57	Pestillo del freno de mano			
172	532 41 56-64	Correa de torsión (LI)/(LD)			
184	532 44 14-55	Manija del freno de mano			
185	872 11 06-22	Perno de 3/8-16 unc x 2-3/4 grado 5			
186	532 19 43-21	Espaciador de retención			
187	819 13 32-10	Arandela de 13/32 x 2 x calibre 10			
188	532 19 43-23	Mecanismo de desplazamiento de la varilla de mando del embrague			

**NOTA:** Las dimensiones de todos los componentes están expresadas en pulgadas americanas.  
1 pulgada = 25,4 mm

TRACTOR MODELO NO. M22-46T (96042014600), PRODUCTO NO. 960 42 01-46  
MOTOR

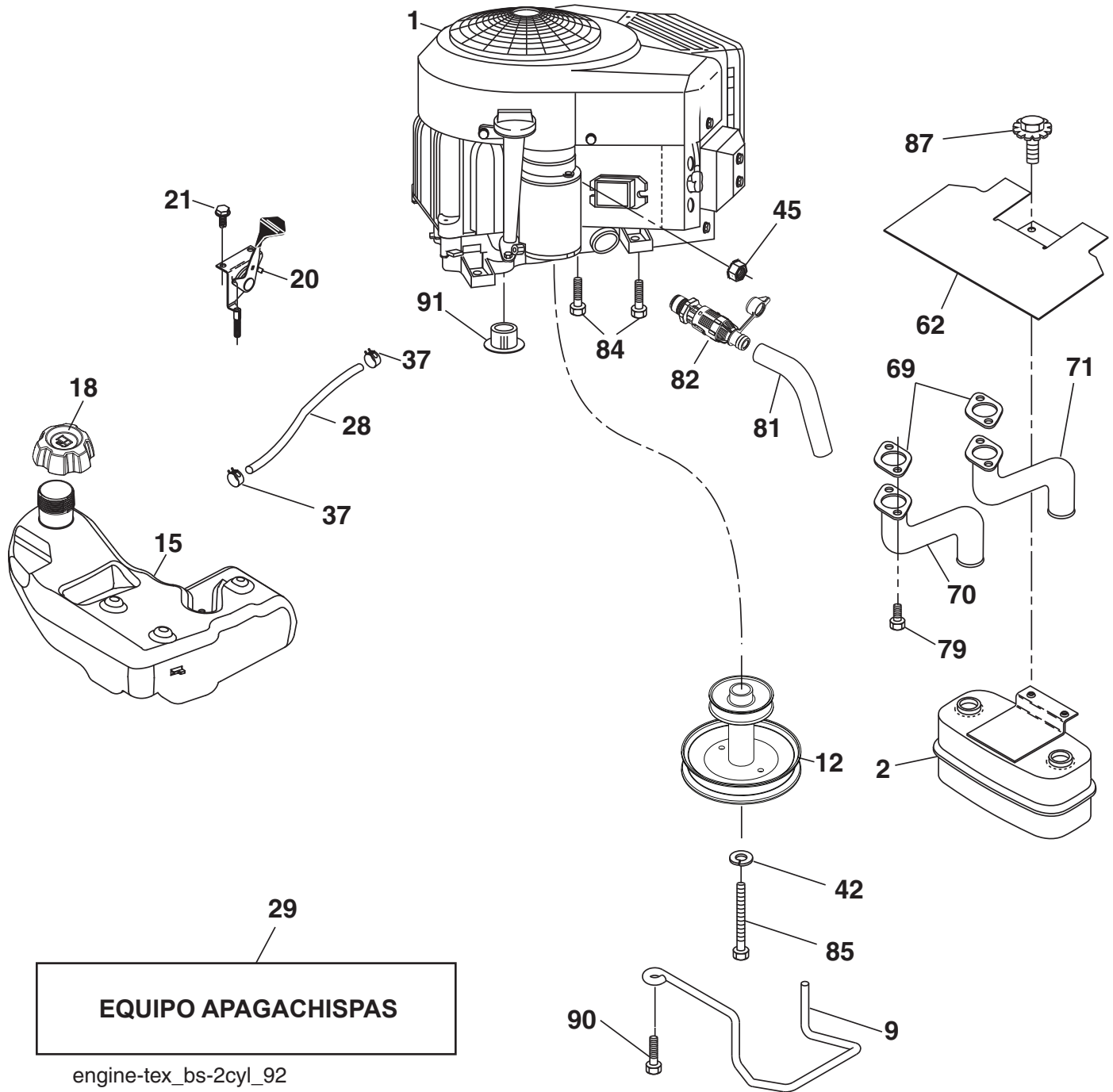

# TRACTOR MODELO NO. M22-46T (96042014600), PRODUCTO NO. 960 42 01-46 MOTOR

CÓDIGO NO.	PIEZA NO.	DESCRIPCIÓN
1	---	Engine b&s model no. 407777-3195-G5 (581081901)(Haga el pedido de las piezas al fabricante del motor.)
2	532 14 97-23	Silenciador
9	532 19 43-19	Ensamble del sujetador de la correa del motor
12	532 40 51-40	Polea del motor
15	532 43 80-80	Tanque de gasolina
18	532 43 02-14	Tapa
20	532 42 35-02	Control de aceleración/estrangulación
21	532 41 63-58	Tornillo de No.10 x 0.750
28	532 13 70-40	Línea de combustible
29	532 13 71-80	Equipo apagachispas
37	532 12 34-87	Abrazadera de la manguera
42	810 04 07-00	Arandela de presión de 7/16
45	873 51 04-00	Nut keps hex 1/4-20 unc
62	532 43 40-17	Silenciador con pantalla térmica
69	532 16 53-91	Junta
70	532 15 99-55	Tubo de escape izquierdo
71	532 16 05-89	Tubo de escape derecho
79	532 18 39-06	Tornillo de 5/16-18 x 1
81	532 14 84-56	Tube drain oil
82	532 42 82-87	Valve oil drain
84	817 06 06-20	Tornillo de 3/8-16 x 1-1/4
85	532 17 39-37	Perno de 7/16-20 x 4 x gr. 5-1.5
87	532 17 18-77	Perno de 5/16-18 unc x 3/4
90	817 00 06-16	Tornillo de 3/8-16 x 1
91	532 18 74-95	Buje

**NOTA:** Las dimensiones de todos los componentes están expresadas en pulgadas americanas.  
1 pulgada = 25,4 mm

Para las piezas del servicio y de recambio del motor, llame el número gratis para su fabricante del motor enumerado abajo:

Briggs & Stratton 1-800-233-3723

## Información de Clasificación de Potencia del Motor

La clasificación de potencia para un modelo de motor a gas en particular se designa de acuerdo al código J1940 de SAE (Sociedad de Ingenieros Automotrices) (Procedimiento de Clasificación de Potencia & Torque del Motor Pequeño), y la clasificación de desempeño ha sido obtenida y corregida de acuerdo con el código J1995 de SAE (Revisión 2002-05). Los valores de torque se obtienen a 3060 RPM; los valores de potencia se obtienen a 3600 RPM. La potencia bruta actual del motor será inferior y está afectada, entre otras cosas, por las condiciones ambientales operativas y la variabilidad de motor a motor. Dado ambos un amplio conjunto de productos en los cuales son puestos nuestros motores, y la variedad de emisiones ambientales aplicables al operar el equipo, el motor a gas no desarrollará la potencia nominal cuando sea usado en una parte del equipo acoplado (potencia real "en el-sitio" o potencia neta). Esta diferencia se debe a una variedad de factores que incluyen, pero que no están limitados a, accesorios (filtro de aire, sistema de escape, sistema de carga, sistema de enfriamiento, carburador, bomba de combustible, etc.) limitaciones de la aplicación, condiciones ambientales de operación (temperatura, humedad, altitud), y la variabilidad de motor a motor. Debido a las limitaciones, Briggs & Stratton puede sustituir este motor con clasificación de potencia más alta por esta serie de motor.

**TRACTOR MODELO NO. M22-46T (96042014600), PRODUCTO NO. 960 42 01-46**  
**ENSAMBLE DE LA DIRECCIÓN**

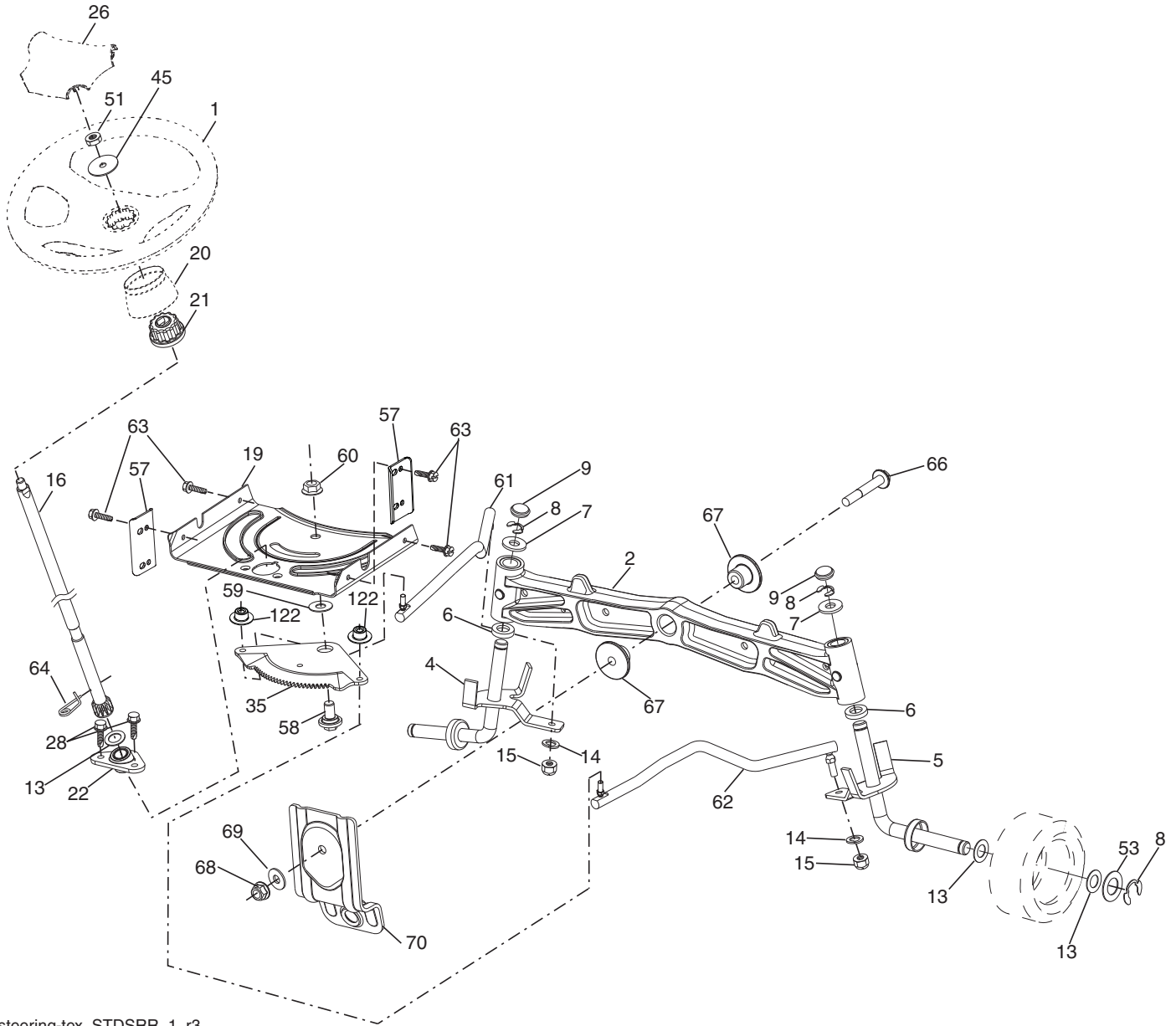

steering-tex\_STDSRR\_1\_r3

**TRACTOR MODELO NO. M22-46T (96042014600), PRODUCTO NO. 960 42 01-46  
ENSAMBLE DE LA DIRECCIÓN**

<b>CÓDIGO NO.</b>	<b>PIEZA NO.</b>	<b>DESCRIPCIÓN</b>
1	532 44 28-04	Volante de dirección
2	532 19 59-68	Ensamble del eje delantero
4	532 40 30-87	Ensamble del husillo izquierdo
5	532 40 30-88	Ensamble del husillo derecho
6	532 12 49-31	Pista del rodamiento para reforzar el impulso
7	532 12 17-48	Arandela de 25/32 x 1-5/8 calibre 16
8	812 00 00-29	Abrazadera del aro no. T5304-75
9	532 12 12-32	Tapa del husillo
13	532 12 17-49	Arandela de 25/32 x 1-1/4 x calibre 16
14	810 04 06-00	Arandela de presión de 3/8
15	873 54 06-00	Tuerca de 3/8-24 unf
16	532 40 82-19	Eje de dirección
19	532 19 47-29	Placa de dirección
20	532 42 47-40	Cubierta de la dirección
21	532 18 67-37	Adaptador del volante de dirección
22	532 42 05-37	Dirección apoyo inferior
26	532 44 77-59	Inserto del volante de dirección
28	817 00 06-12	Tornillo de 3/8-16 x 3/4
35	532 19 47-32	Engranaje del sector de la placa
45	819 18 38-12	Arandela de 9/16 x 2-3/8 x 12 ga.
51	873 94 08-00	Contratuerca hexagonal de seguridad de 1/2-20 unf
53	532 18 89-67	Arandela de .793 X 1.637 X .060
57	532 40 74-65	Tope superior del soporte
58	532 19 47-47	Perno de tope del sector del pivote cfm
59	532 19 47-48	Arandela de empuje del sector de dirección
60	873 97 10-00	Tuerca de presión con brida de 5/8-11
61	532 19 47-40	Barra de acoplamiento izquierda
62	532 19 47-41	Barra de acoplamiento derecha
63	817 00 05-12	Tornillo de 5/16-18 x 3/4
64	532 19 98-49	Abrazadera de retención del resorte de la dirección
66	871 02 07-48	Perno de cabeza hexagonal con brida acanalada de 7/16-14 x 3
67	532 19 47-37	Buje pm del eje delantero
68	873 90 07-00	Tuerca de presión con brida de 7/16-14 grado 5
69	532 19 91-62	Arandela de 1.5 X .505 X .118
70	532 19 61-97	Soporte de la plataforma delantera
122	532 44 49-62	Engranaje del sector de la tapas

**NOTA:** Las dimensiones de todos los componentes están expresadas en pulgadas americanas. 1 pulgada = 25,4 mm



**TRACTOR MODELO NO. M22-46T (96042014600), PRODUCTO NO. 960 42 01-46  
PLATAFORMA DE LA CORTADORA DE CÉSPED**

CÓDIGO NO.	PIEZA NO.	DESCRIPCIÓN	CÓDIGO NO.	PIEZA NO.	DESCRIPCIÓN
1	532 44 16-11	Carcasa de la cortadora de césped	69	872 14 05-05	Perno
2	532 40 55-07	Cubierta izquierda del mandril	70	532 19 99-72	Ensamble del embrague Manual
3	532 40 55-06	Cubierta derecha del mandril	113	817 00 05-10	Perno de 5/16-18
6	532 19 51-86	Brazo de la suspensión	116	532 12 48-42	Perno de tope
7	532 41 63-58	Tornillo No.10 x 0.750	117	532 18 86-06	Calibrador de la rueda
8	532 19 30-03	Perno/arandela del ensamble de 7/16-20 unf	119	819 12 14-14	Arandela de 3/8 x 7/8 x calibre 14
11	532 40 53-80	Cuchilla	122	532 19 72-58	Sujetador izquierdo de la correa del motor
13	532 19 28-72	Ensamble del eje del mandril	123	532 19 72-59	Sujetador derecho de la correa del motor
14	532 18 72-81	Carcasa del mandril	144	532 19 92-04	Sujetador de la correa
15	532 11 04-85	Rodamiento de bolas del mandril	145	532 19 73-79	Polea loca
19	532 19 65-39	Perno de tope	147	532 40 18-72	Retorno del resorte
21	873 68 05-00	Tuerca corona de presión de 5/16-18 unc	152	532 43 51-11	Cable de embrague manual con resorte
23	532 19 25-57	Soporte del deflector	188	532 19 51-61	Sujetador del travesaño
24	532 10 53-04	Tapa de la manga	189	873 90 05-00	Tuerca de presión hexagonal con brida
25	532 19 70-26	Resorte de torsión del deflector	195	817 00 06-12	Tornillo de 3/8-16 x 3/4
26	532 11 04-52	Tuerca de presión	197	819 13 13-12	Arandela de 13/32 x 13/16 x calibre 12
27	532 40 53-57	Protector del deflector	198	532 40 31-49	Deflector delantero central
29	532 13 14-91	Varilla de la bisagra	199	532 40 31-50	Deflector delantero derecho
30	532 17 39-84	Tornillo con cabeza de arandela	200	532 41 35-24	Arandela de 13/32 x 1 x 1/2 x calibre 11
31	532 18 76-90	Arandela del separador	240	874 52 06-36	Perno de cabeza hexagonal con aleta de 3/8-16 x 2-1/4 grado 5
32	532 19 74-73	Polea del mandril	241	532 15 29-27	Tornillo de No.10-32.5 3/8
33	532 40 02-34	Tuerca de seguridad con brida	242	532 41 55-98	Puerto De Lavado De La Cubierta
34	872 11 06-12	Perno de cabeza de hongoy cuello cuadrado de 3/8-16 x 1-1/2 grado 5	--	532 41 64-05	Accesorio del conexión
36	532 19 31-97	Polea loca	--	532 19 28-70	Ensamble del Mandril (solo incluye la carcasa (key No. 14), el ensamble del eje (key No. 13) el rodamiento (key No. 15), y tuerca (key No. 33); no incluye la polea/arandela ni los pernos/arandelas de la cuchilla)
37	819 13 13-16	Arandela de 13/32 x 13/16 x calibre 16	--	532 41 80-63	Reemplazo de la cortadora de césped, completa
38	532 43 25-20	Sujetador de la correa			
40	873 90 06-00	Tuerca de presión con brida de 3/8-16 unc			
42	532 19 84-10	Resorte de torsión del freno			
43	532 19 72-56	Resorte de torsión de retención			
46	532 13 77-29	Tornillo de 1/4-20 x 5/8			
47	532 19 72-50	Cable de embrague			
55	532 19 72-49	Brazo de la polea			
56	532 19 90-92	Espaciador de retención			
57	817 00 06-16	Tornillo de 3/8-16 x 1			
59	532 14 10-43	Dispositivo de protección de la polea			
60	532 19 94-71	Brazo del freno de la cortadora de césped			
63	532 19 94-77	Brazo del freno de la cortadora de césped			
64	532 40 51-38	Ensamble del varillaje del freno			
67	532 40 30-12	Manija del cable de embrague			
68	532 40 51-43	Correa			

**NOTA:** Las dimensiones de todos los componentes están expresadas en pulgadas americanas.  
1 pulgada = 25,4 mm

**TRACTOR MODELO NO. M22-46T (96042014600), PRODUCTO NO. 960 42 01-46  
ELEVACIÓN DE LA CORTADORA DE CÉSPED**

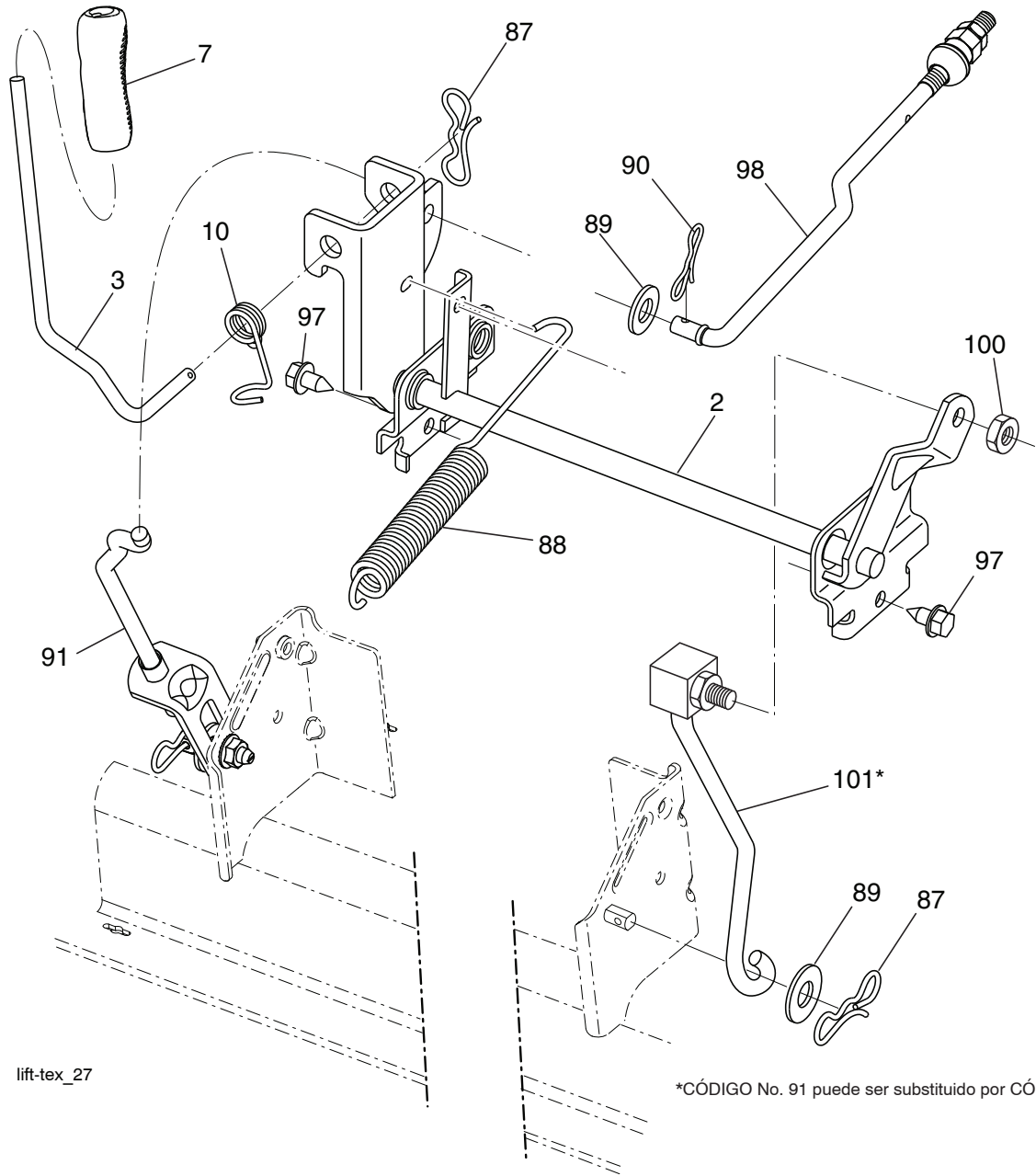

lift-tex\_27

\*CÓDIGO No. 91 puede ser substituido por CÓDIGO No. 101

CÓDIGO NO.	PIEZA NO.	DESCRIPCIÓN
2	532 42 20-27	Ensamble del eje de la elevación
3	532 19 52-31	Ensamble de la palanca de elevación derecha
7	580 96 23-01	Mango de la palanca
10	532 19 63-14	Resorte de torsión
87	532 19 42-09	Pasador de chaveta de 7/16 con bloqueo en forma de mariposa
88	532 41 07-10	Resorte de ayuda de la elevación
89	819 19 19-12	Arandela de zinc transparente
90	532 19 42-08	Pasador de chaveta de 5/16 con bloqueo en forma de mariposa
91	581 89 70-01	Acoplamiento trasera de la elevación de la cortadora de césped

CÓDIGO NO.	PIEZA NO.	DESCRIPCIÓN
97	817 00 06-12	Tornillo de 3/8-16 x 3/4
98	581 50 69-01	Acoplamiento frontal de la elevación de la cortadora de césped
100	873 93 06-00	Tuerca de presión central de 3/8-16 unc
101	581 89 71-01	Ensamble del acoplamiento Elevación

**NOTA:** Las dimensiones de todos los componentes están expresadas en pulgadas americanas.  
1 pulgada = 25,4 mm



**TRACTOR MODELO NO. M22-46T (96042014600), PRODUCTO NO. 960 42 01-46  
ENSAMBLE DEL ASIENTO**

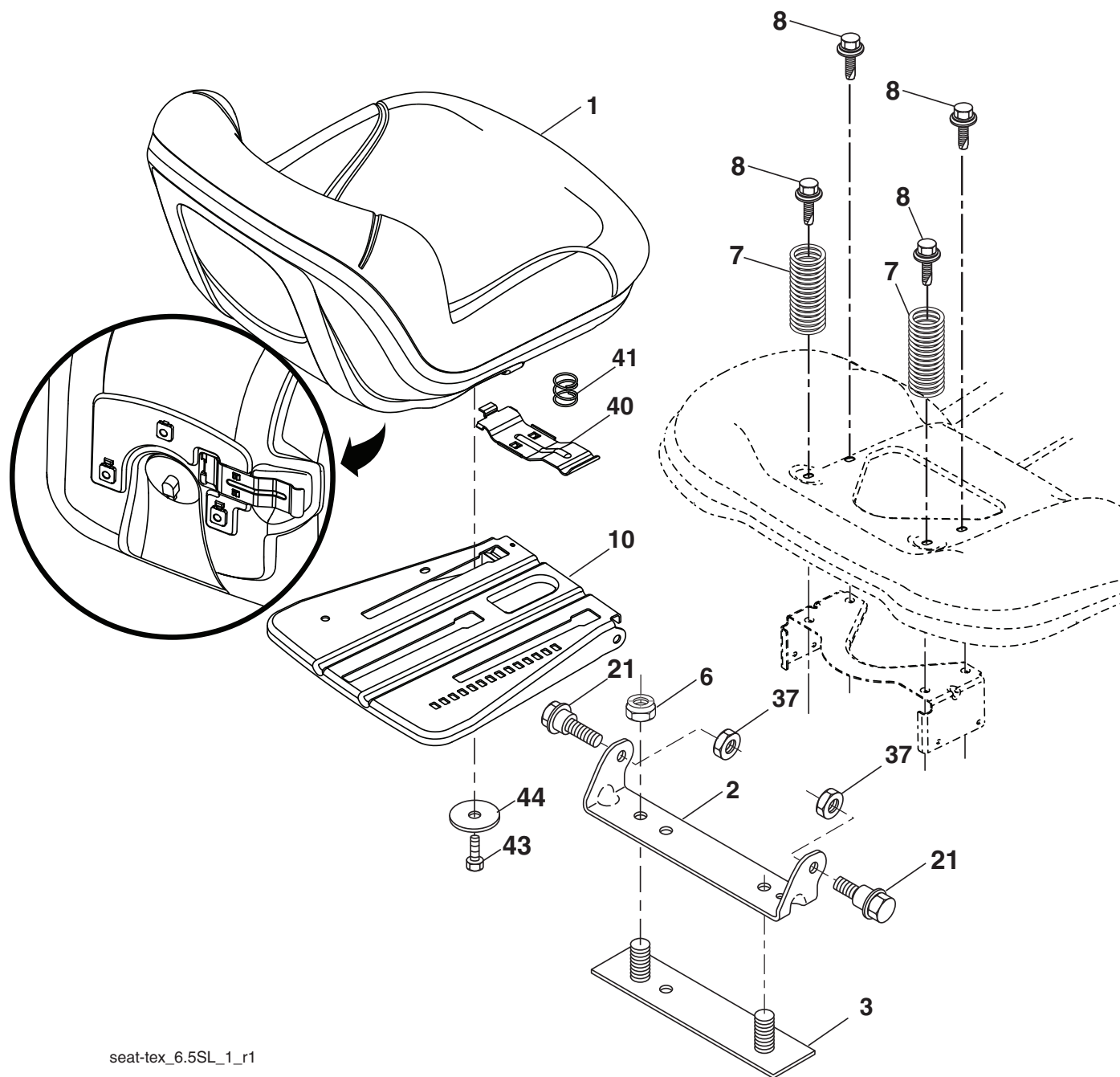

seat-tex\_6.5SL\_1\_r1

CÓDIGO NO.	PIEZA NO.	DESCRIPCIÓN
1	581 46 22-01	Asiento
2	532 18 01-66	Soporte pivotante del guardabarros
3	532 14 06-75	Conector del ensamble del guarda barros
6	873 80 06-00	Tuerca de presión c/aislamiento de 3/8-16 unc
7	532 12 41-81	Resorte del asiento
8	532 17 18-77	Perno de 5/16" unc x 3/4"
10	532 19 69-77	Bandeja del asiento
21	532 17 18-52	Perno de tope de 5/16-18
37	873 80 05-00	Tuerca de presión de 5/16-18 unc

CÓDIGO NO.	PIEZA NO.	DESCRIPCIÓN
40	532 19 76-61	Manija para deslizar el asiento
41	532 19 82-00	Resorte para trabar el asiento
43	874 76 06-12	Perno de 3/8-16 unc x 3/4
44	819 13 38-12	Arandela de 13/32 x 2-3/8 calibre 12

**NOTA:** Las dimensiones de todos los componentes están expresadas en pulgadas americanas.  
1 pulgada = 25,4 mm

**TRACTOR - - MODELO NO. M22-46T (96042014600), PRODUCTO NO. 960 42 01-46  
CALCOMANÍAS**

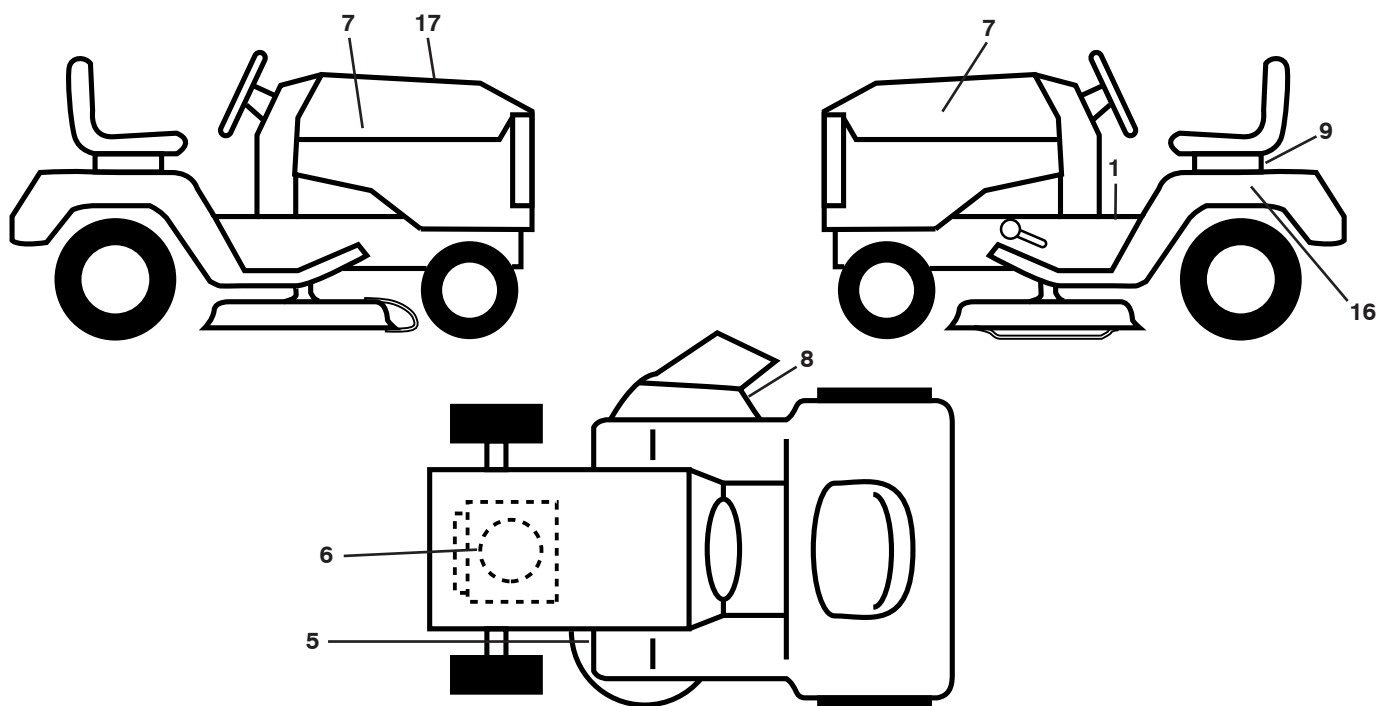

CÓDIGO NO.	PIEZA NO.	DESCRIPCIÓN
1	581 57 89-01	Calcomanía, Leer el manual
5	581 58 00-01	Calcomanía del Diagrama de correa
6	581 25 85-01	Calcomanía, caballo de fuerza del Motor
7	581 09 12-01	Calcomanía para la capota (LI)/(LD)
8	581 57 95-01	Calcomanía, advertencia
9	532 14 50-05	Calcomanía de Peligro/Punto de interconexión

CÓDIGO NO.	PIEZA NO.	DESCRIPCIÓN
16	581 98 08-01	Calcomanía para el guardabarros
17	581 59 33-01	Calcomanía de reemplazo
--	581 72 48-01	Calcomanía para la desviación
--	532 40 95-05	Forro del apoyo para los pies (LI)
--	532 40 95-07	Forro del apoyo para los pies
--	115 56 35-27	Manual del operario (INGLÉS/ESPAÑOL)
--	583 87 21-27	Manual de repuestos (INGLÉS/ESPAÑOL)

**RUEDAS Y NEUMÁTICOS**

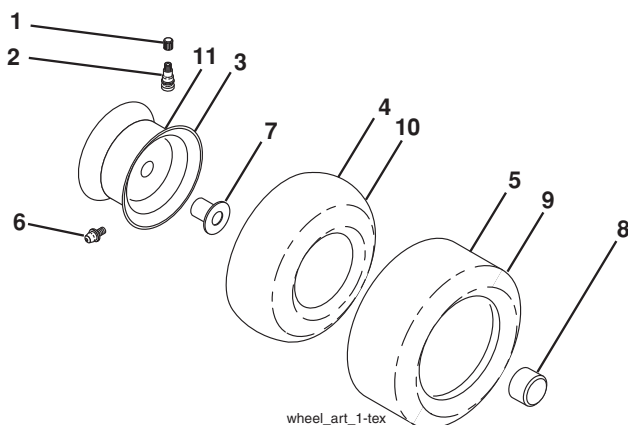

CÓDIGO NO.	PIEZA NO.	DESCRIPCIÓN
1	532 05 91-92	Tapa de la válvula del neumático
2	532 06 51-39	Vástago de la válvula
3	532 12 51-21	Ensamble de las llantas delanteras
4	532 05 99-04	Cámara delantera
5	532 10 62-22	Neumático delantero
6	532 12 49-57	Accesorio para engrasar
7	532 12 49-59	Rodamiento de la brida
8	532 19 32-68	Tapa del eje
9	532 13 84-68	Neumático trasero
10	532 12 49-26	Cámara trasera
11	532 12 51-22	Ensamble trasero de la llanta
--	532 14 43-34	Sellador para neumáticos (tubo de 10 onzas [283 gr])

**NOTA:** Las dimensiones de todos los componentes están expresadas en pulgadas americanas.  
1 pulgada = 25,4 mm

---

# NOTES/AVISO

---

