

# **ILLUSTRATED PARTS LIST**

**MODEL NO. 96041029700**

**CUSTOMER CATALOG NO. M185-117T**

**PRODUCT NO. 960 41 02-97**

**TRACTOR -- MODEL NO. M185-117T (96041029700), PRODUCT NO. 960 41 02-97  
DECALS 27**

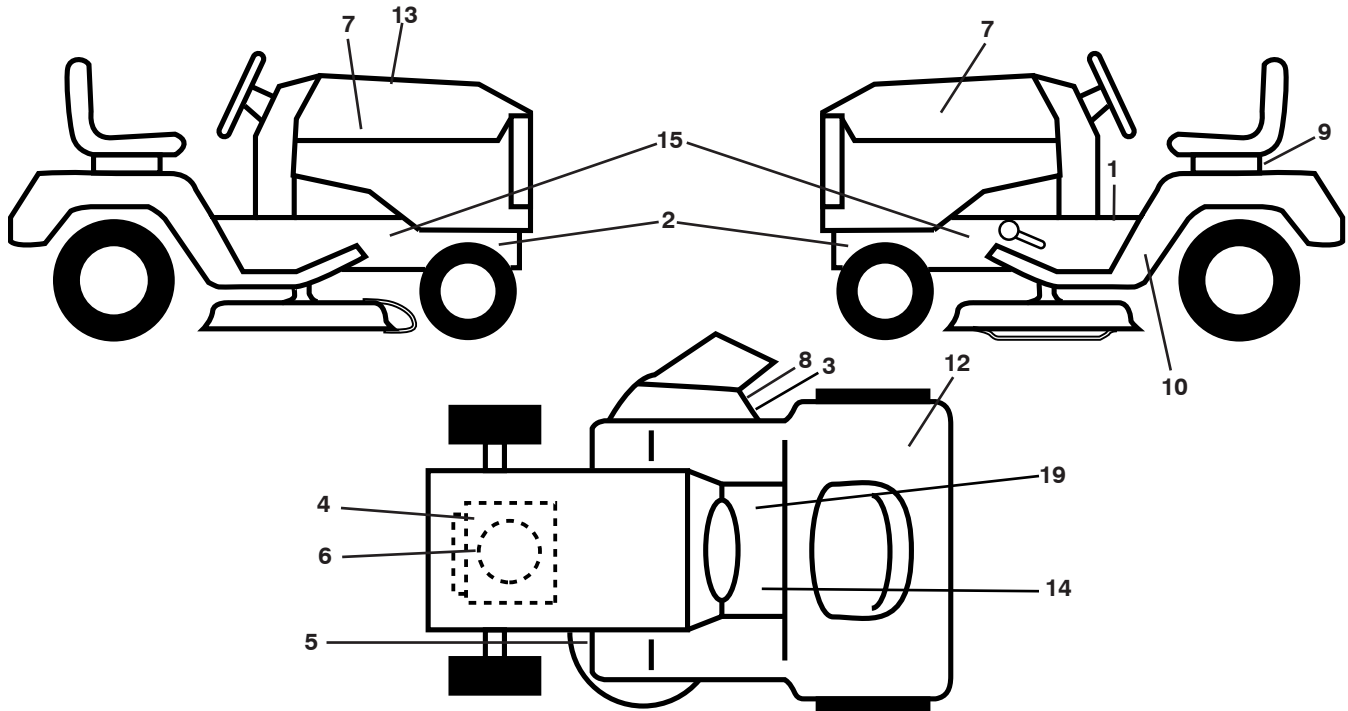

KEY NO.	PART NO.	DESCRIPTION
1	581 57 81-01	Decal, Warning Sym.
2	581 57 98-01	Decal, Warning Service/Fire
3	581 57 92-01	Decal, Warning
4	581 57 97-01	Decal, Warning Engine
5	581 58 00-01	Decal, V-Belt Sch.
6	532 43 74-20	Decal, Eng. HP
7	581 09 12-01	Decal, Hood LH/RH
8	581 57 91-01	Decal, Cutfinger
9	532 14 50-05	Decal, Battery Dnge/Poi
10	581 53 32-01	Decal, Fender Side

KEY NO.	PART NO.	DESCRIPTION
12	581 72 41-01	Decal, Fender DB/CE
13	581 59 20-01	Decal, Replacement
14	581 72 40-01	Decal, FNDR
15	581 57 96-01	Decal, Hot Muffler
19	581 57 80-01	Decal, Saddle Brake Parking
--	581 72 48-01	Decal, Bypass
--	581 72 46-01	Decal, Load Limit
--	532 40 95-05	Pad, Footrest, LH
--	532 40 95-07	Pad, Footrest, RH
--	115 55 90-20	Manual, Oper Euro

**WHEELS AND TIRES**

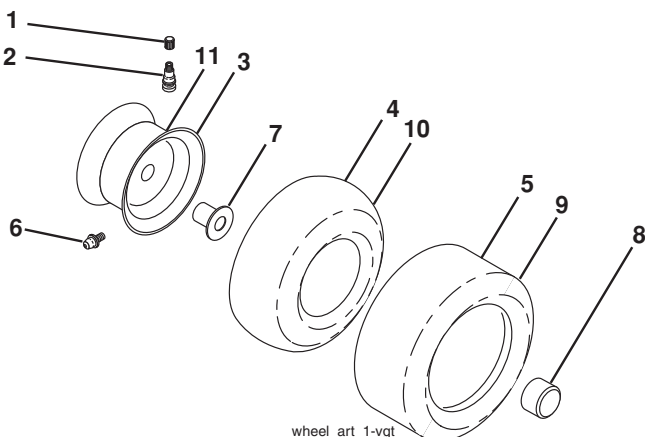

wheel\_art\_1-vgt

KEY NO.	PART NO.	DESCRIPTION
1	532 05 91-92	Cap, Valve, Tire
2	532 06 51-39	Stem, Valve
3	532 12 51-21	Rim Assembly, Front
4	532 05 99-04	Tube, Front (Service Item Only)
5	532 10 62-22	Tire, Front
6	532 12 49-57	Fitting, Grease (Front Wheel Only)
7	532 12 49-59	Bearing, Flange (Front Wheel Only)
8	532 19 32-68	Cap, Axle
9	532 13 84-68	Tire, Rear
10	532 12 49-26	Tube, Rear (Service Item Only)
11	532 12 51-22	Rim Assembly, Rear
--	532 14 43-34	Sealant, Tire (10 oz. Tube)

**NOTE:** All component dimensions given in U.S. inches  
1 inch = 25.4 mm

# TRACTOR - - MODEL NO. M185-117T (96041029700), PRODUCT NO. 960 41 02-97

## SCHEMATIC **38**

SCH13

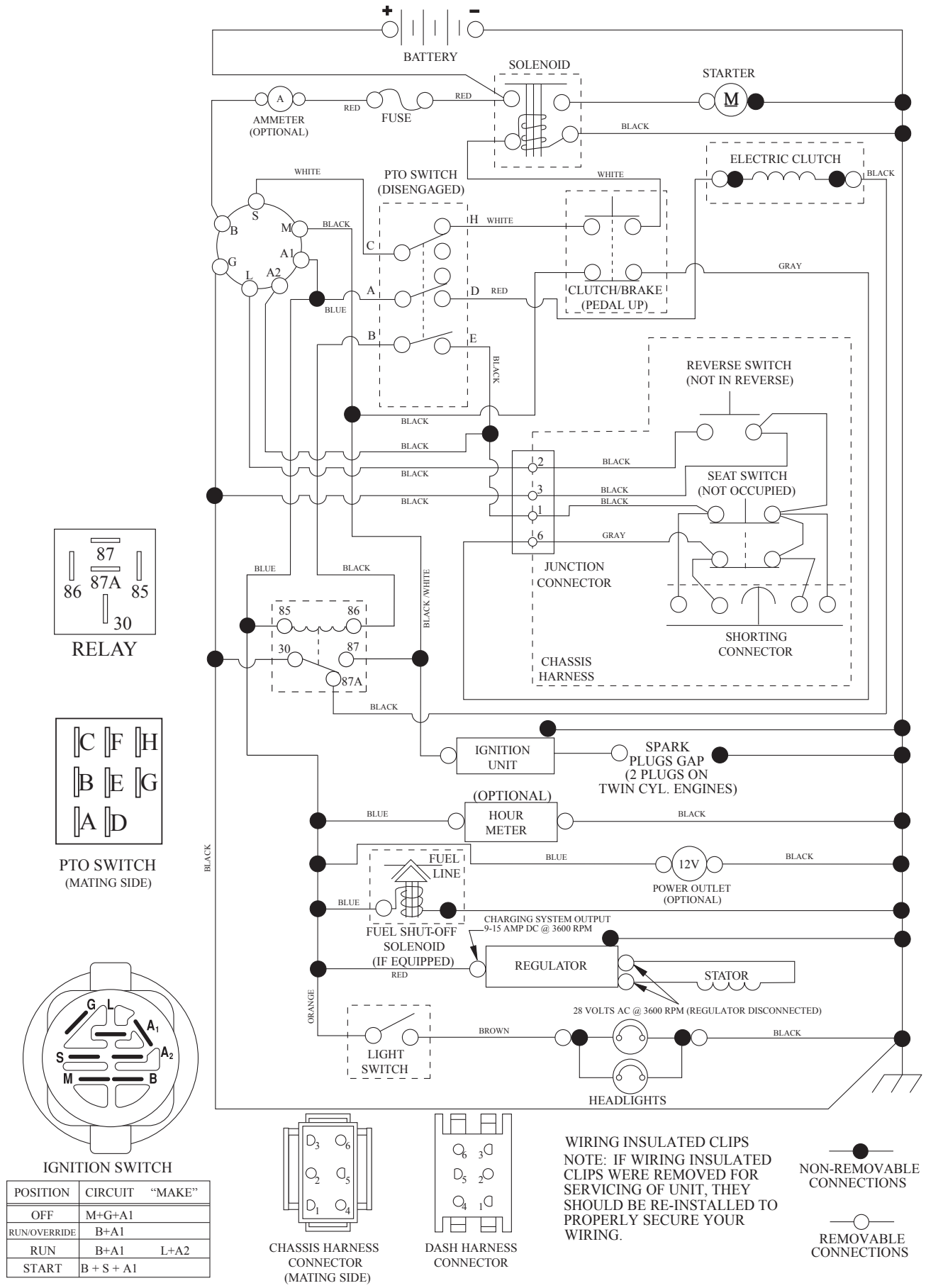

**TRACTOR - - MODEL NO. M185-117T (96041029700), PRODUCT NO. 960 41 02-97**  
**ELECTRICAL 32**

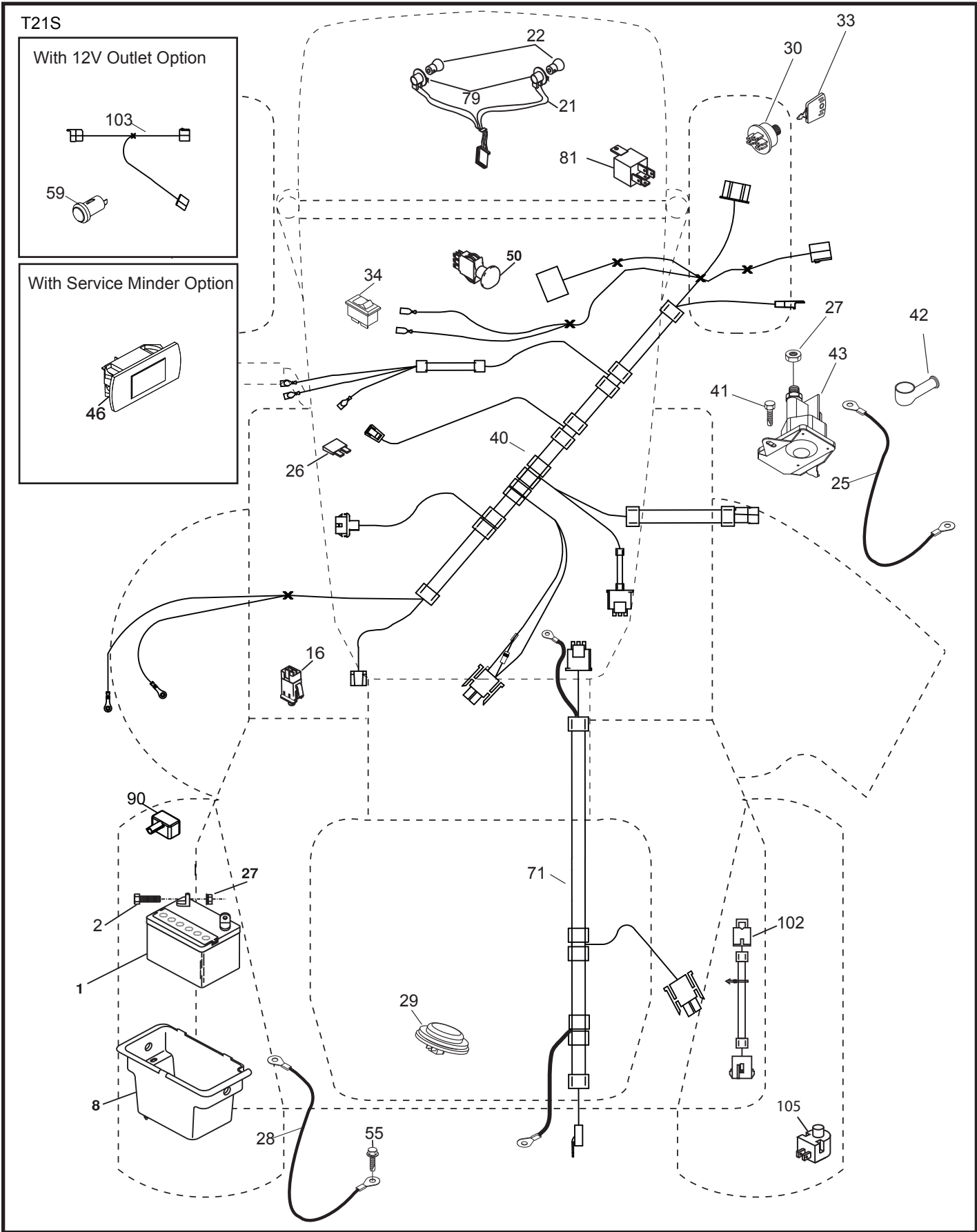

**TRACTOR - - MODEL NO. M185-117T (96041029700), PRODUCT NO. 960 41 02-97  
ELECTRICAL 32**

<b>KEY NO.</b>	<b>PART NO.</b>	<b>DESCRIPTION</b>
1	532 16 34-65	Battery
2	874 76 04-12	Bolt Hex Hd 1/4-20 unc x 3/4
8	532 19 32-28	Battery Box
16	532 17 61-38	Switch Interlock
21	532 40 02-52	Harness Socket Light
22	532 00 41-52	Bulb, Light # 1156
25	585 55 55-01	Cable Starter
26	532 17 51-58	Fuse
27	873 51 04-00	Nut Keps Hex 1/4-20 unc
28	532 19 88-85	Cable Ground
29	532 40 15-45	Switch Seat
30	532 19 33-50	Switch Ign
33	532 41 19-35	Key/Chain
34	532 11 07-12	Switch Light/Reset
40	532 40 96-14	Harness Ign. Dash/Lift
41	817 72 04-08	Screw Thd Cut 1/4-20 x 1/2
42	532 13 15-63	Cover Terminal Red
43	532 19 25-07	Solenoid
50	532 17 46-51	Switch PTO
55	817 06 05-12	Screw Thdrol 5/16-18 x 3/4
71	532 44 15-44	Harness Ign. Chassis/Lift
79	532 17 52-42	Socket Asm. Bulb
81	532 40 96-15	Relay Harness
90	532 43 53-95	Cover Terminal Battery
102	581 02 34-01	Harness Pigtail
105	532 40 75-68	Switch Reverse

**NOTE:** All component dimensions given in U.S. inches  
1 inch = 25.4 mm

**TRACTOR - - MODEL NO. M185-117T (96041029700), PRODUCT NO. 960 41 02-97**  
**CHASSIS AND ENCLOSURES 39**

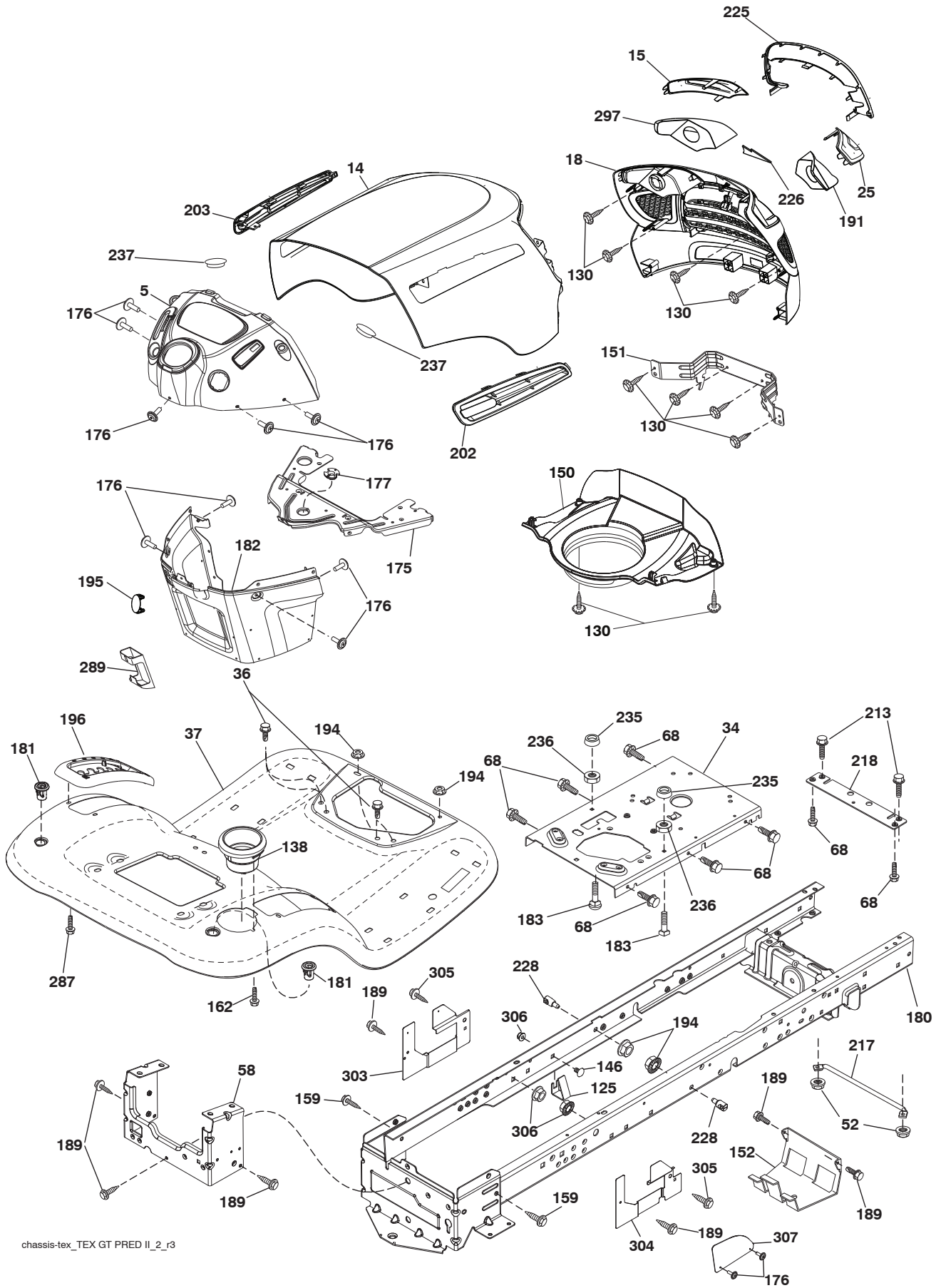

chassis-tex\_TEX GT PRED II\_2\_r3

**TRACTOR - - MODEL NO. M185-117T (96041029700), PRODUCT NO. 960 41 02-97  
CHASSIS AND ENCLOSURES 39**

KEY NO.	PART NO.	DESCRIPTION
5	532 42 47-38	Dash
14	532 44 80-42	Hood
15	581 10 31-01	Lens LH
18	581 10 29-01	Grille
25	581 10 30-01	Lens RH
34	580 91 08-01	Plate Engine
36	817 06 05-12	Screw 5/16-18 x 3/4
37	532 42 07-96	Fender
52	873 68 05-00	Nut Crown Lock 5/16
58	532 41 22-80	Drawbar
68	817 49 05-08	Screw THDROL 5/16-18 x 1/2
125	581 68 48-01	Clip Fuel Line
130	532 41 63-58	Screw
138	532 40 97-30	Cupholder
146	581 85 79-01	Bolt
150	584 86 29-03	Air Duct
151	532 44 54-94	Bracket Pivot
152	532 19 95-35	Shield Browning
159	817 00 06-12	Screw 3/8-16 x 3/4
162	532 14 24-32	Screw 1/4 x 1/2
175	532 19 63-04	Crossmember
176	532 40 07-76	Screw 10-24 x 5/8
177	532 19 52-27	Bushing Steering
180	532 41 50-63	Chassis
181	532 40 47-96	Bushing Mtg. Fender Crgo
182	532 40 68-59	Dash Lower
183	874 52 05-20	Bolt 5/16-18 x 1-1/4
189	817 00 05-12	Screw 5/16-18 x 3/4
191	581 22 35-01	Reflector RH

KEY NO.	PART NO.	DESCRIPTION
194	873 90 05-00	Nut Lock Hex Flange 5/16-18
195	532 40 41-37	Plug Hole Dash Lower
196	532 41 45-81	Console Asm. Deck Lift
202	581 85 91-01	Side Vent RH
203	581 85 92-01	Side Vent LH
213	874 76 05-12	Bolt 5/16-18 x 3/4
217	532 40 91-67	Rod Pivot Hood
218	532 19 63-95	X-Piece Hood Stop
225	581 10 32-01	Trim Ring
226	578 89 71-01	Emblem
228	532 19 51-61	Stud Fastener
235	532 40 61-29	Spacer Fender
236	873 93 05-00	Nut Lock 5/16-18 unc
237	532 40 37-04	Plug Mount Cargo
287	817 60 04-06	Screw Hex Washhead 1/4-20 x 3/8
289	532 40 35-71	Plug Cruise/Phone
297	581 22 36-01	Reflector LH
303	532 42 09-59	Shield Chassis French LH
304	532 42 15-09	Shield Chassis French RH
305	872 11 06-06	Bolt RDHD SHT SQNK 3/8-16 x 3/4
306	873 90 06-00	Nut Lock Flg. 3/8-16 unc
307	532 42 45-70	Shield Upper Pedal
--	532 44 11-26	Plug Dash SRVMNDR.
--	532 40 09-44	Bumper Kit

**NOTE:** All component dimensions given in U.S. inches  
1 inch = 25.4 mm

TRACTOR -- MODEL NO. M185-117T (96041029700), PRODUCT NO. 960 41 02-97  
DRIVE **40**

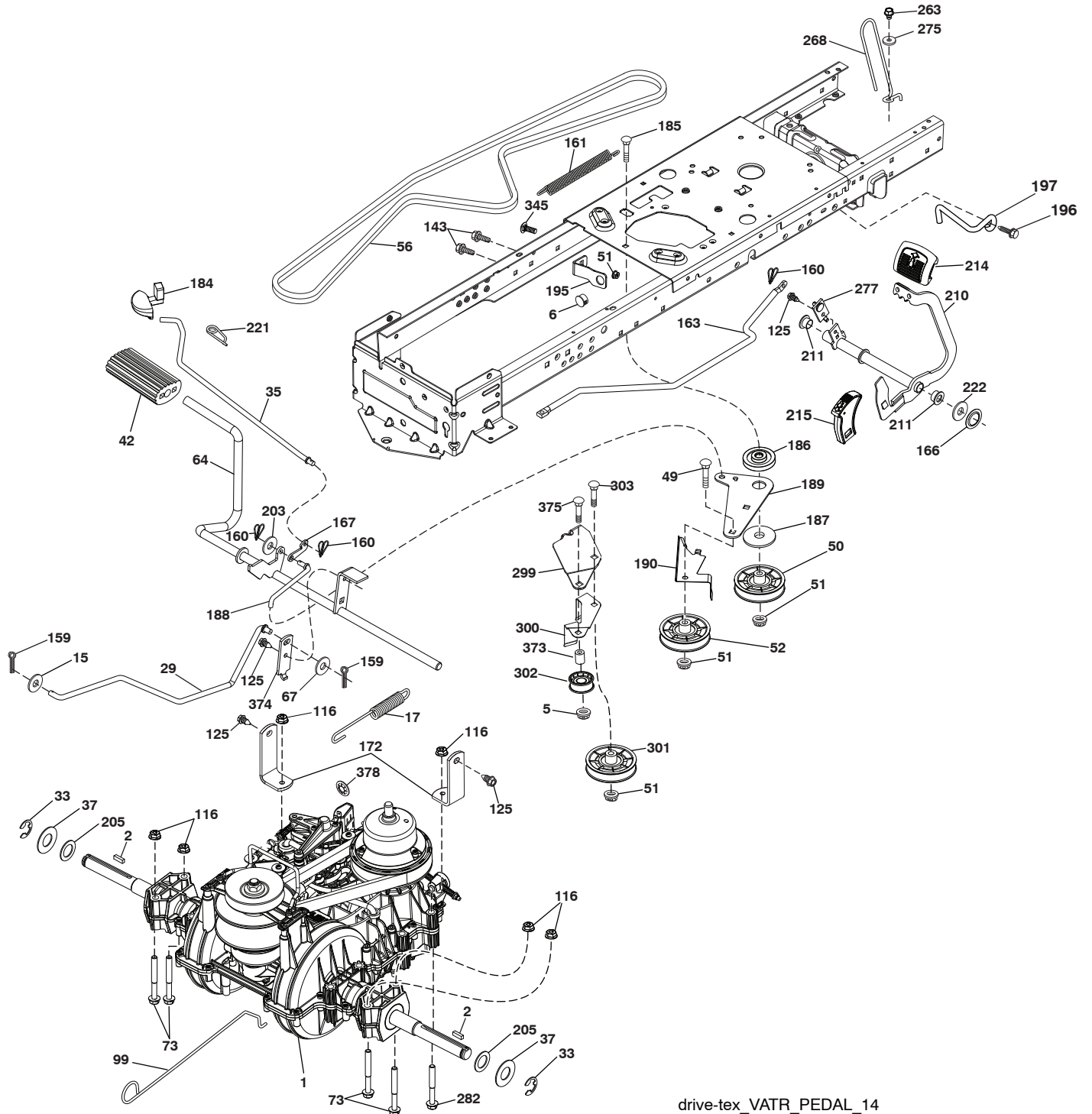

drive-tex\_VATR\_PEDAL\_14



**TRACTOR - - MODEL NO. M185-117T (96041029700), PRODUCT NO. 960 41 02-97  
DRIVE 40**

KEY NO.	PART NO.	DESCRIPTION	KEY NO.	PART NO.	DESCRIPTION
1	---	Transaxle, Variator SD Pedal (580486201) (Order parts from transaxle manufacturer.)	187	819 13 32-10	Washer 13/32 x 2 x 10 ga
2	532 12 35-83	Key Square	188	532 19 43-23	Link Clutch Ground Drive
5	873 68 06-00	Nut Crownlock 3/8-16 unc	189	532 19 43-17	Bellcrank Ground Drive
6	532 12 40-28	Bushing Snap	190	532 19 43-18	Keeper. Bellcrank
15	819 13 13-16	Washer 13/32 x 13/16 x 16 Ga.	195	581 50 46-01	Bracket Brake
17	532 41 36-78	Spring, Brake	196	817 00 06-16	Screw 3/8-16 x 1
29	581 47 93-01	Rod, Brake	197	585 65 86-01	Link Clutch Anti-Rotation 1" CRK
33	812 00 00-01	Ring E	203	819 11 11-16	Washer 11/32 x 11/16 x 16
35	583 86 45-01	Rod, Brake, Park	205	532 12 17-48	Washer 25/32 x 1-5/8 16 Ga.
37	532 18 89-67	Washer .793 x 1.637 x 060	210	532 44 82-70	Rocker Asm. Pedal
42	532 12 48-72	Cover, Foot Pedal	214	532 42 12-63	Pedal Forward
49	872 11 06-14	Bolt 3/8-16 unc	215	532 44 82-54	Pad Pedal Reverse
50	532 19 43-27	Idler Flat	211	532 12 01-83	Bearing Nylon
51	873 90 06-00	Nut Lock	221	532 40 31-87	Retainer Spring
52	532 19 43-26	Idler V-Groove	222	879 21 20-10	Washer Flat
56	581 60 38-01	V-Belt, Drive	263	817 00 06-12	Screw
64	532 44 83-53	Subasm. Shaft Pedal Brake	268	532 18 24-02	Guard.Muffler
67	819 13 13-12	Washer 13/32 x 13/16 x 12 Ga.	275	819 13 16-14	Washer 13/32 x 1 x 14
73	874 49 05-44	Bolt Hex 5/16-18 x 3.75	277	532 44 85-00	Subasm. Link Rocker Pedal
99	532 43 59-35	Rod Bypass	282	874 49 05-48	Bolt Hex 5/16-18x
116	873 90 05-00	Nut Lock Hex Flange 5/16-18	299	532 41 56-83	Bracket Mount
125	817 00 05-12	Screw 5/16-18 x 3/4	300	532 41 56-81	Keeper Idler
143	817 49 05-08	Screw Thdrol 5/16-18 x 1/2 TYTT	301	532 41 56-80	Pulley Idler Groove
159	876 02 04-12	Pin Cotter 1/8 x 3/4	302	581 42 05-01	Puller Idler Flat
160	532 16 94-84	Retainer Clip	303	872 11 06-18	Bolt
161	532 10 57-09	Spring, Return, Clutch	345	872 11 06-06	Bolt RDHD
163	532 44 82-68	Rod Control	373	581 46 18-01	Spacer Idler
166	532 42 91-64	Nut Push .625	374	581 47 52-01	Arm Control Brake
167	532 40 52-57	Latch Brake Parking	375	874 76 06-36	Bolt Hex HS 3/8-16 unc x 2-1/4
172	583 97 42-01	Strap Torque Variator	378	584 28 77-01	Nut Push 8MM
184	532 44 14-55	Handle Park Brk.			
185	872 11 06-22	Bolt 3/8-16 unc x 2-3/4			
186	532 19 43-21	Spacer Retainer			

**NOTE:** All component dimensions given in U.S. inches  
1 inch = 25.4 mm

TRACTOR - - MODEL NO. M185-117T (96041029700), PRODUCT NO. 960 41 02-97  
 ENGINE **24**

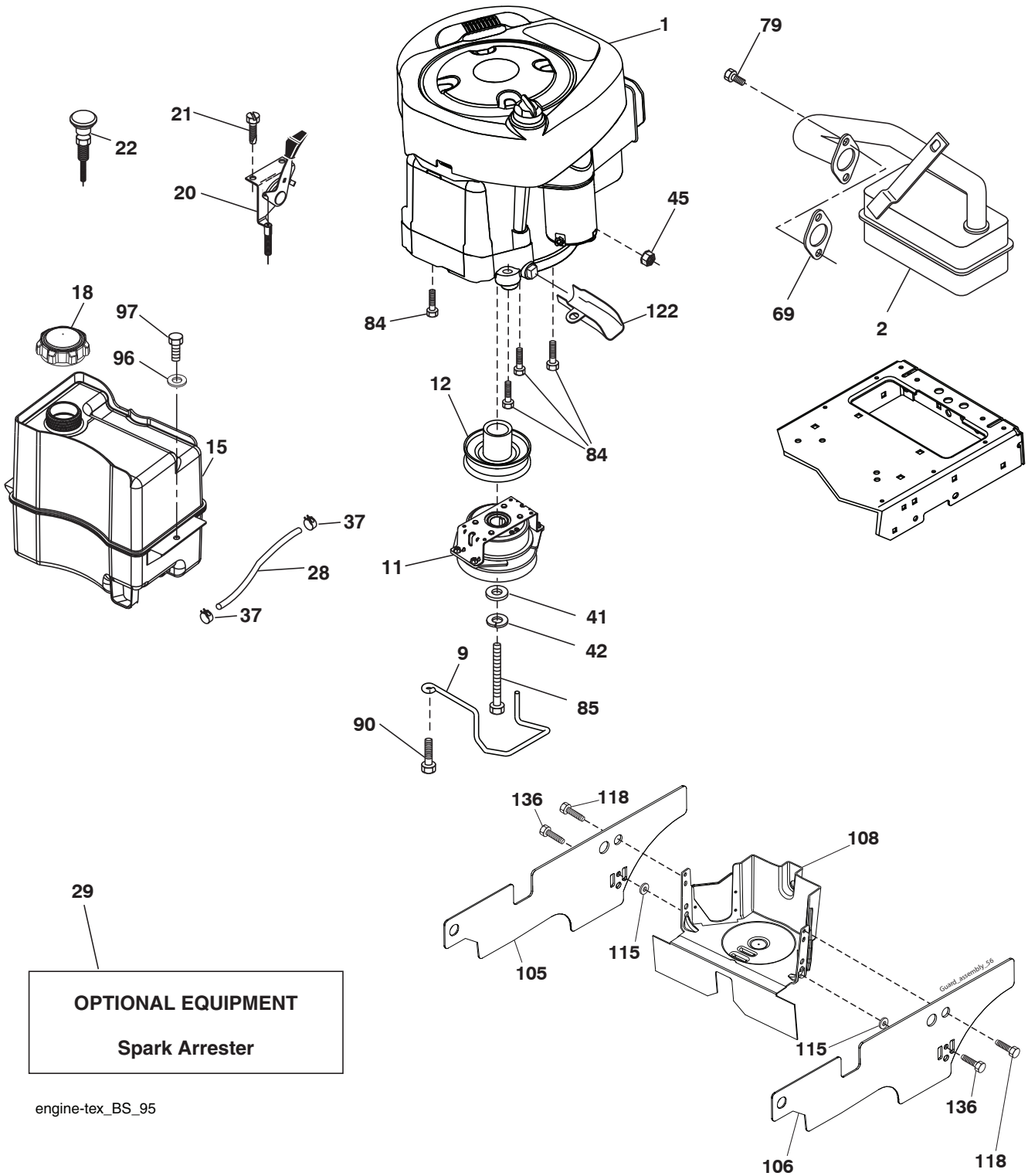

**OPTIONAL EQUIPMENT**  
**Spark Arrester**

engine-tex\_BS\_95

**TRACTOR - - MODEL NO. M185-117T (96041029700), PRODUCT NO. 960 41 02-97  
ENGINE 24**

KEY NO.	PART NO.	DESCRIPTION
1	- - - - -	Engine Briggs Model No. 31N707-2437-B1 (438593) (Order parts from engine manufacturer.)
2	532 13 73-52	Muffler
9	532 19 43-20	Keeper Belt Engine
11	587 24 16-01	Clutch Electric
12	532 40 50-97	Pulley Engine
15	532 40 75-51	Tank Fuel
18	532 43 02-20	Cap Asm
20	532 40 15-08	Control Throttle
21	532 41 63-58	Screw #10 x 0.750 BOS Thread
22	532 19 49-81	Control Choke
28	532 13 70-40	Fuel Line
29	532 13 71-80	Spark Arrester Kit
37	532 12 34-87	Clamp Hose
41	532 12 61-97	Washer 1-1/2 OD x 15/32 ID x .250
42	810 04 07-00	Washer Lock 7/16
45	873 51 04-00	Nut Keps Hex 1/4-20 unc
69	532 16 52-91	Gasket
79	532 19 23-34	Screw 5/16-18 x .75
84	817 06 06-20	Screw 3/8-16 x 1-1/4
85	532 17 99-53	Bolt 7/16-20 x 3.75 Gr.
90	817 00 06-16	Screw 3/8-16 x 1
96	819 09 14-16	Washer 9/32 x 7/8 x 16 Ga.
97	817 67 04-12	Screw 1/4 - 20 x 3/4
105	532 41 56-06	Shield Side LH
106	532 41 56-11	Shield Side RH
108	532 42 68-03	Cover Asm. Pulley
115	532 42 30-62	Palnut 1/4
118	817 67 05-08	Screw Thdrol 5/16-18 x 1/2
122	532 42 19-22	Extension Drain Oil
136	532 13 77-29	Screw Thdrol 1/4-20 x 5/8

**NOTE:** All component dimensions given in U.S. inches  
1 inch = 25.4 mm

**Engine Power Rating Information**

The gross power rating for individual gas engine models is labeled in accordance with SAE (Society of Automotive Engineers) code J1940 (Small Engine Power & Torque Rating Procedure), and rating performance has been obtained and corrected in accordance with SAE J1995 (Revision 2002-05). Torque values are derived at 3060 RPM; horsepower values are derived at 3600 RPM. Actual gross engine power will be lower and is affected by, among other things, ambient operating conditions and engine-to-engine variability. Given both the wide array of products on which engines are placed and the variety of environmental issues applicable to operating the equipment, the gas engine will not develop the rated gross power when used in a given piece of power equipment (actual "on-site" or net power). This difference is due to a variety of factors including, but not limited to, accessories (air cleaner, exhaust, charging, cooling, carburetor, fuel pump, etc.), application limitations, ambient operating conditions (temperature, humidity, altitude), and engine-to-engine variability. Due to manufacturing and capacity limitations, Briggs & Stratton may substitute an engine of higher rated power for this Series engine.

**TRACTOR -- MODEL NO. M185-117T (96041029700), PRODUCT NO. 960 41 02-97**  
**STEERING ASSEMBLY [41]**

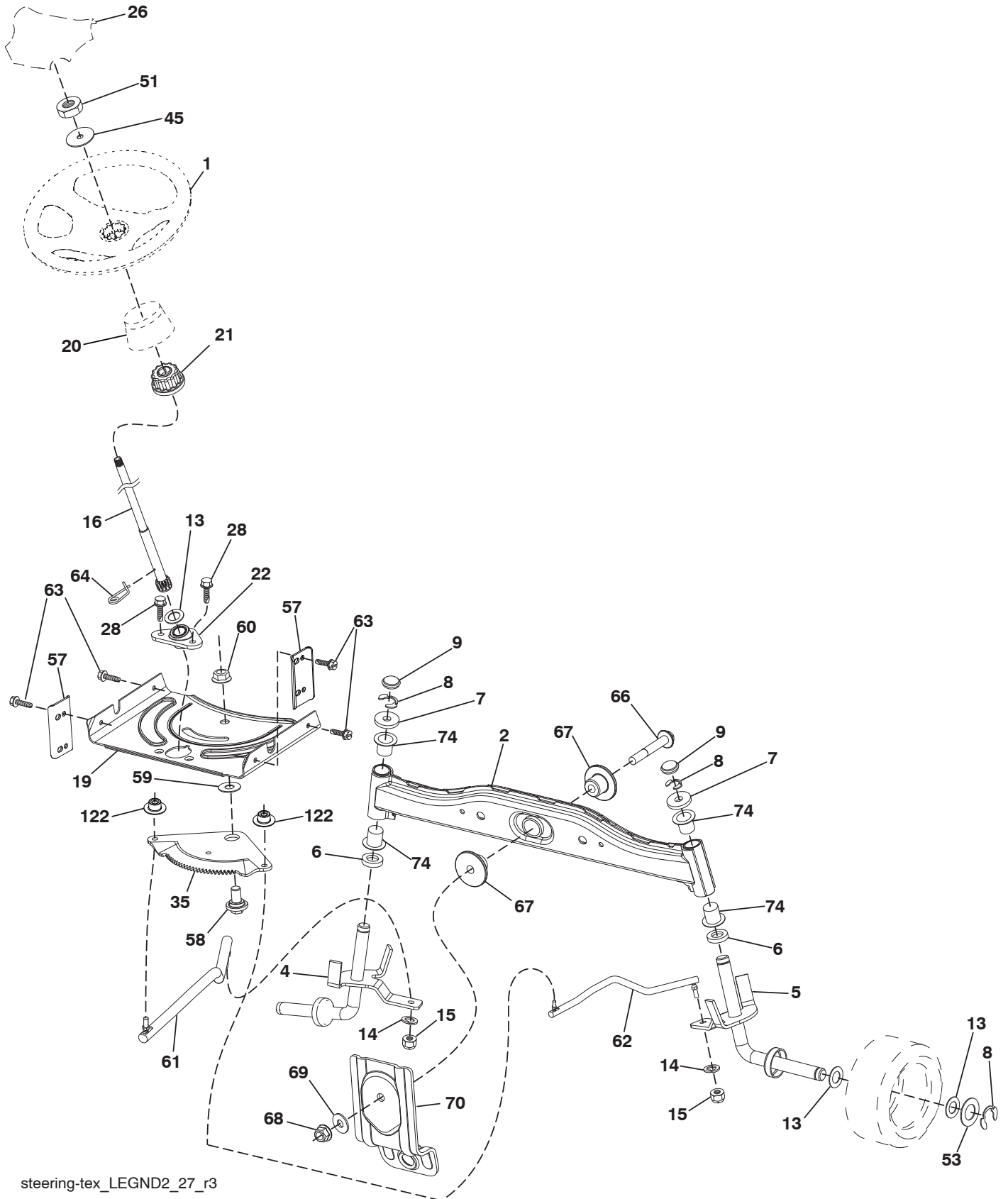

steering-tex\_LEGND2\_27\_r3

**TRACTOR - - MODEL NO. M185-117T (96041029700), PRODUCT NO. 960 41 02-97  
STEERING ASSEMBLY 41**

<b>KEY NO.</b>	<b>PART NO.</b>	<b>DESCRIPTION</b>
1	532 44 28-04	Wheel, Steering
2	532 41 81-68	Axle Asm., Front
4	532 40 30-87	Spindle Asm., LH
5	532 40 30-88	Spindle Asm., RH
6	532 12 49-31	Bearing, Race Thrust Harden
7	532 12 17-48	Washer 25/32 x 1-5/8 x 16 Ga.
8	812 00 00-29	Ring, Clip #T5304-75
9	532 12 12-32	Cap, Spindle
13	532 12 17-49	Washer 25/32 x 1-1/4 x 16 Ga.
14	810 04 06-00	Washer, Lock Hvy Hlcl Spr 3/8
15	873 54 06-00	Nut, Crown Lock 3/8-24 unf
16	532 19 47-46	Shaft Steering
19	532 19 47-29	Plate Steering
20	532 42 47-40	Boot Steering
21	532 18 67-37	Adapter, Wheel Steering
22	532 42 05-37	Steering Support Lower
26	532 44 77-59	Insert, Wheel Steering
28	817 00 06-12	Screw 3/8-16 x 3/4
35	532 19 47-32	Gear, Sector Plate
45	819 18 38-12	Washer 9/16 x 2-3/8 12 Ga.
51	873 94 08-00	Nut Hex Jam Toplock 1/2-20 unf
53	532 18 89-67	Washer Hardened .793 x 1.637 x .060
57	532 40 74-65	Bracket Upstop
58	532 19 47-47	Bolt Shoulder Sector Pivot CFM
59	532 19 47-48	Washer Thrust Sector Steering
60	873 97 10-00	Nut Flange Lock 5/8-11
61	532 19 47-40	Draglink LH
62	532 19 47-41	Draglink, RH
63	817 00 05-12	Screw 5/16-18 x 3/4
64	532 19 98-49	Retainer Clip Spring Steering
66	871 02 07-48	Bolt Hex Fghd 7/16-14 x 3 Serr
67	532 19 47-37	Bushing PM Front Axle
68	873 90 07-00	Nut Lock Flange 7/16-14 Gr. 5
69	532 19 91-62	Washer 1.5 x .505 x .118
70	532 19 61-97	Bracket Deck Susp. Front
74	532 12 49-37	Bearing
122	532 44 49-62	Cap Gear Sector

**NOTE:** All component dimensions given in U.S. inches  
1 inch = 25.4 mm

TRACTOR - - MODEL NO. M185-117T (96041029700), PRODUCT NO. 960 41 02-97  
 MOWER DECK 44

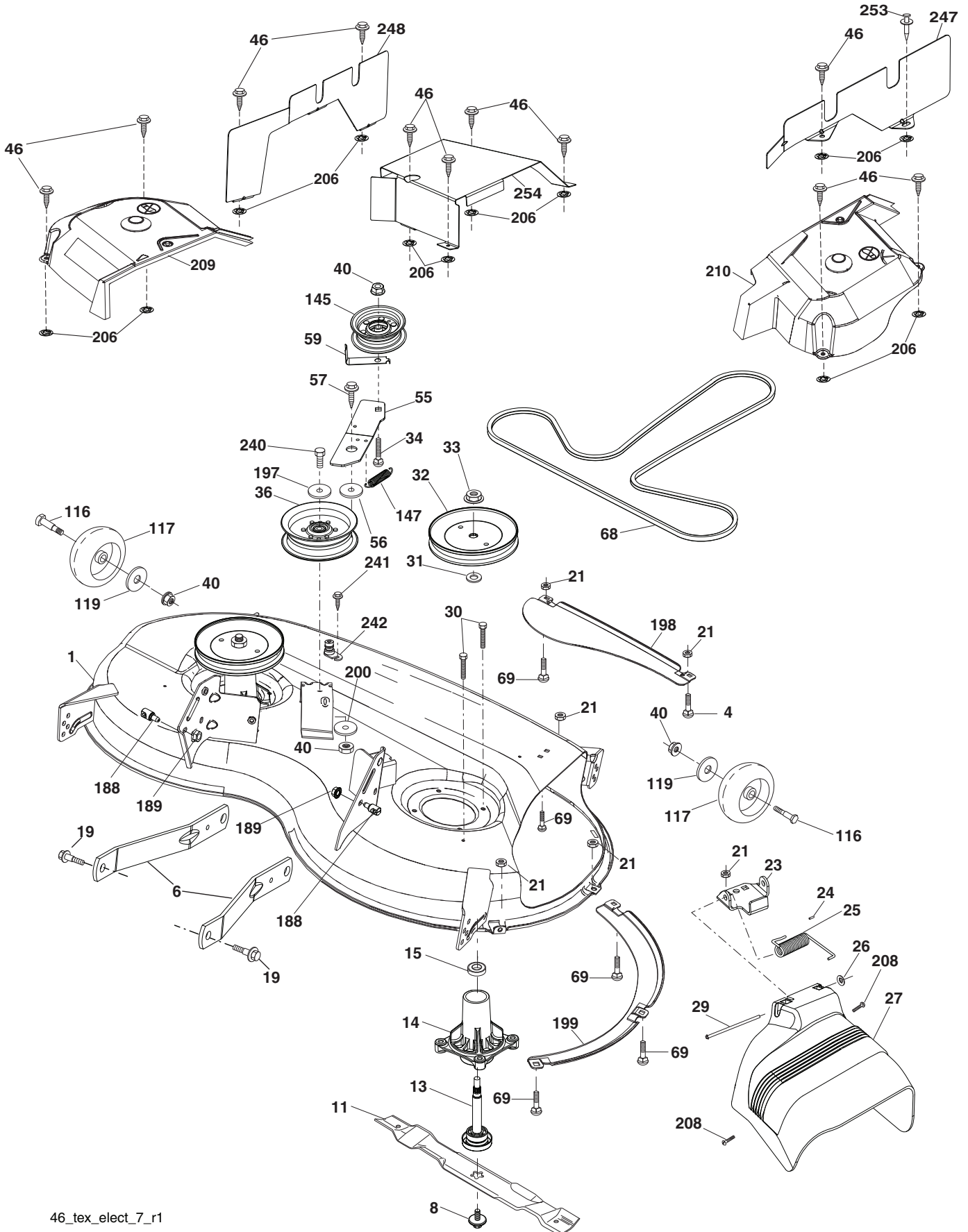

46\_tex\_elect\_7\_r1

**TRACTOR - - MODEL NO. M185-117T (96041029700), PRODUCT NO. 960 41 02-97  
MOWER DECK 44**

KEY NO.	PART NO.	DESCRIPTION	KEY NO.	PART NO.	DESCRIPTION
1	532 44 16-16	Mower Housing	119	819 13 20-12	Washer 13/32 x 1-1/4 x 12 Ga.
4	874 76 05-12	Bolt Hex HD 5/16-18	145	532 19 73-79	Pulley Idler
6	532 19 51-86	Arm Suspension	147	532 19 72-51	Spring Mower Drive Electric
8	532 19 30-03	Bolt/Washer Asm 7/16-20 unf	188	532 19 51-61	Stud Fastener
11	532 40 53-80	Blade	189	873 90 05-00	Nut Lock Hex Flange
13	532 19 28-72	Shaft Assembly, Mandrel	197	819 13 13-12	Washer 13/32 x 13/16 x 12 Ga.
14	532 18 72-81	Housing, Mandrel	198	532 40 31-49	Baffle Center Front
15	532 11 04-85	Bearing, Ball, Mandrel	199	532 40 31-50	Baffle Front RH
19	532 19 65-39	Bolt, Shoulder	200	532 41 35-24	Washer 13/32 x 1 x 1/2 x 11 Ga.
21	873 68 05-00	Nut, Crownlock 5/16-18 unc	206	532 42 30-62	Palnut 1/4
23	532 19 25-57	Bracket, Deflector	208	817 67 06-08	Screw 3/8-16 x 1/2
24	532 10 53-04	Cap, Sleeve	209	532 42 49-86	Cover Mandrel LH
25	532 19 70-26	Spring, Torsion, Deflector	210	532 43 10-87	Cover Mandrel RH
26	532 11 04-52	Nut, Push	240	874 52 06-36	Bolt Fin Hex 3/8-16 x 2-1/4 Gr. 5
27	532 44 28-95	Shield, Deflector	241	532 15 29-27	Screw #10-32.5 3/8 Flange
29	532 13 14-91	Rod, Hinge	242	532 41 55-98	Port Washout
30	532 17 39-84	Screw Thdrol Rolling Wsh Hd	247	532 43 02-63	Shield Deck RH
31	532 18 76-90	Washer, Spacer	248	532 43 02-62	Shield Deck LH
32	532 19 74-73	Pulley, Mandrel	253	532 42 73-50	Rivet Tuflok .25 x .24
33	532 40 02-34	Nut, Toplock, Flanged	254	532 43 02-64	Shield Deck Rear
34	872 11 06-12	Bolt Carr Sh. 3/8-16 x 1-1/2 Gr. 5	--	532 19 28-70	Mandrel Assembly (Includes Housing (key #14), Shaft Assembly(key #13), and Bearing (key #15)Only - Pulley/ Nut/Washer And Blade Bolt/Washers Not Included)
36	532 19 31-97	Pulley, Idler, Primary	--	532 42 72-24	Replacement Mower, Complete
40	873 90 06-00	Nut, Lock Flg. 3/8-16 unc			
46	532 13 77-29	Screw Thdrol 1/4-20 x 5/8			
55	532 19 72-49	Arm, Idler			
56	532 19 90-92	Spacer, Retainer			
57	817 00 06-16	Screw 3/8-16 x 1			
59	532 14 10-43	Guard, Tuv Idler			
68	532 40 51-43	Belt, Drive			
69	872 14 05-05	Bolt			
116	532 19 34-06	Bolt, Shoulder			
117	532 17 48-73	Wheel, Gauge			

**NOTE:** All component dimensions given in U.S. inches  
1 inch = 25.4 mm



**TRACTOR -- MODEL NO. M185-117T (96041029700), PRODUCT NO. 960 41 02-97**  
**MOWER LIFT 45**

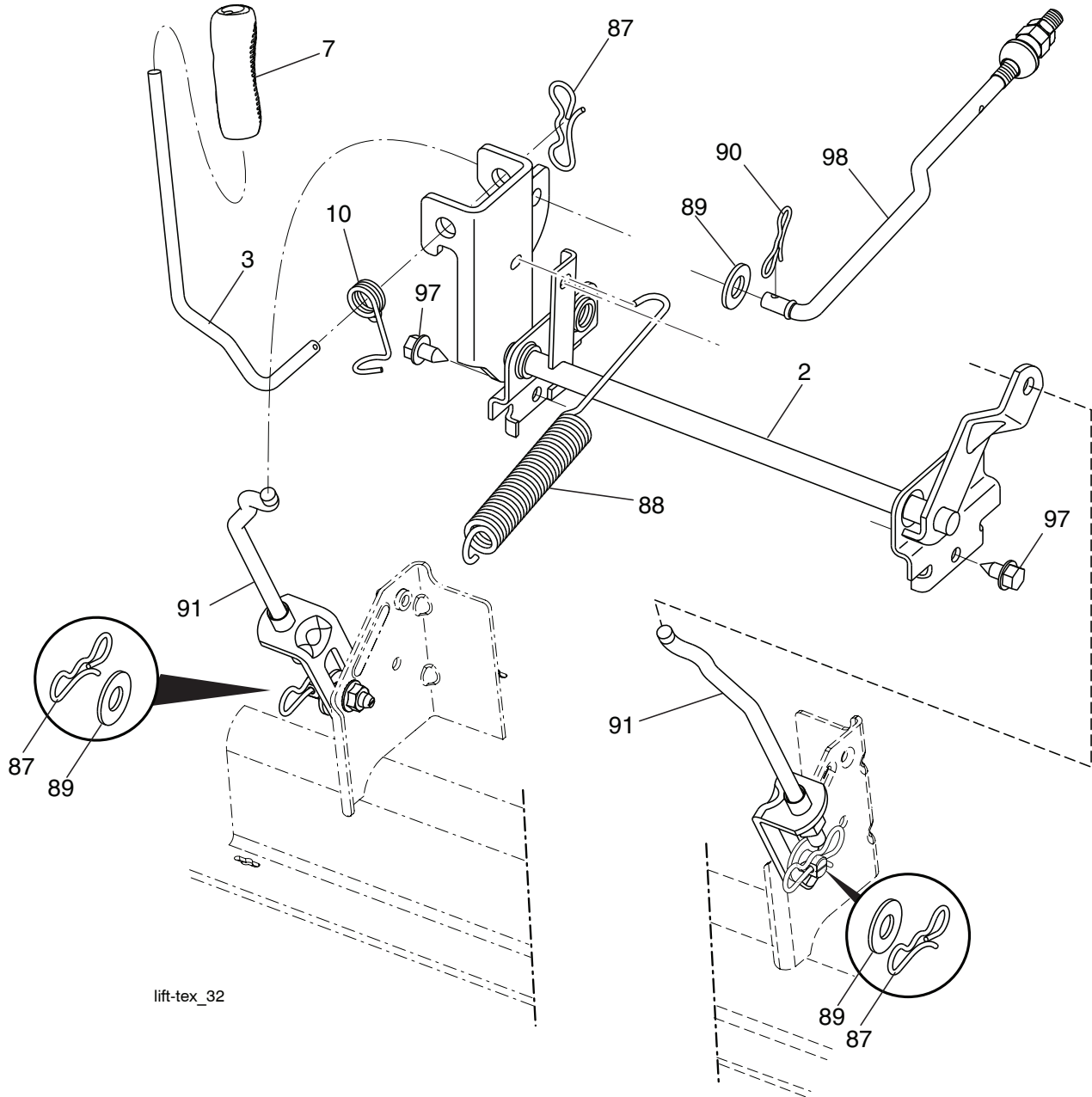

lift-tex\_32

KEY NO.	PART NO.	DESCRIPTION
2	532 42 20-27	Shaft Asm., Lift
3	532 19 52-31	Lever Asm., Lift RH
7	580 96 23-01	Grip, Lever
10	532 19 63-14	Spring Torsion
87	532 19 42-09	Pin Cotter 7/16 Bow Tie Lock
88	532 41 07-10	Spring Lift Assist
89	819 19 19-12	Washer 17/32 x 1-3/16 x 12 Ga.
90	532 19 42-08	Pin Cotter 5/16 Bow Tie Lock

KEY NO.	PART NO.	DESCRIPTION
91	532 19 79-84	Link Lift Susp Mower Rear
97	817 00 06-12	Screw 3/8-16 x .75
98	532 42 05-25	Link Lift Susp. Front Mower

**NOTE:** All component dimensions given in U.S. inches  
 1 inch = 25.4 mm



**TRACTOR - - MODEL NO. M185-117T (96041029700), PRODUCT NO. 960 41 02-97  
SEAT ASSEMBLY 42**

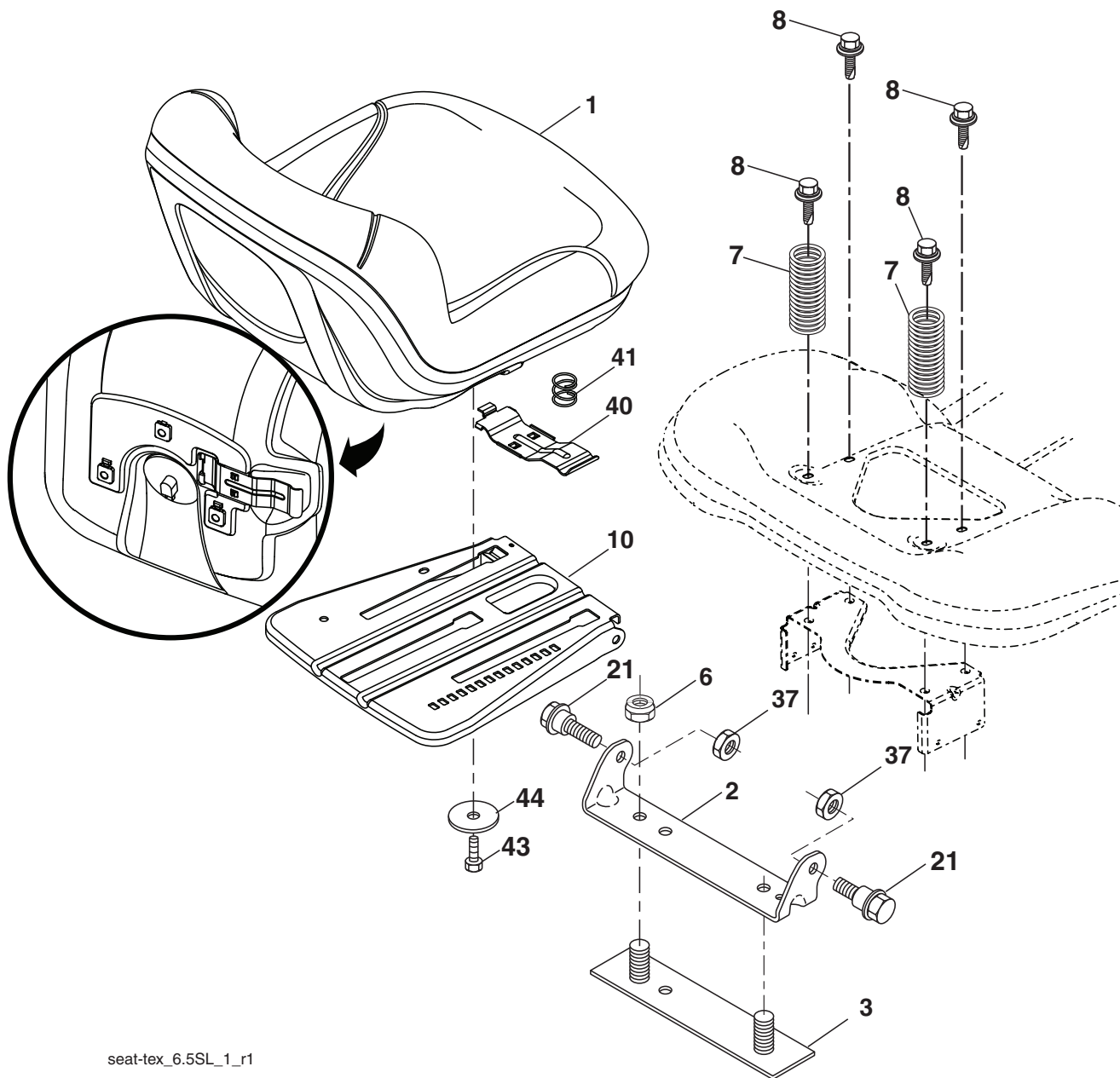

seat-tex\_6.5SL\_1\_r1

KEY NO.	PART NO.	DESCRIPTION
1	581 46 22-01	Seat
2	532 18 01-66	Bracket Pivot Fender
3	532 14 06-75	Strap, Asm Fender
6	873 80 06-00	Nut, Lock w/Ins. 3/8-16 unc
7	532 12 41-81	Spring, Seat Cprsn
8	532 17 18-77	Bolt 5/16-18 unc x 3/4 w/Sems
10	532 19 69-77	Pan, Seat
21	532 17 18-52	Bolt, Shoulder 5/16-18

KEY NO.	PART NO.	DESCRIPTION
37	873 80 05-00	Nut, Lock 5/16-18 unc
40	532 19 76-61	Handle Slide Seat
41	532 19 82-00	Spring Latch Seat
43	874 76 06-12	Bolt 3/8-16 x 3/4
44	819 13 38-12	Washer 13/32 x 2-3/8 x 12 Ga.

**NOTE:** All component dimensions given in U.S. inches  
1 inch = 25.4 mm

