

ILLUSTRATED PARTS LIST

MFG. ID NO. 96051006800

CUSTOMER CATALOG NO. M200-107TC

PRODUCT NO. 960 51 00-68

**TRACTOR - MODEL NO. M200-107TC (96051006800), PROD. NO. 960 51 00-68
DECALS 27**

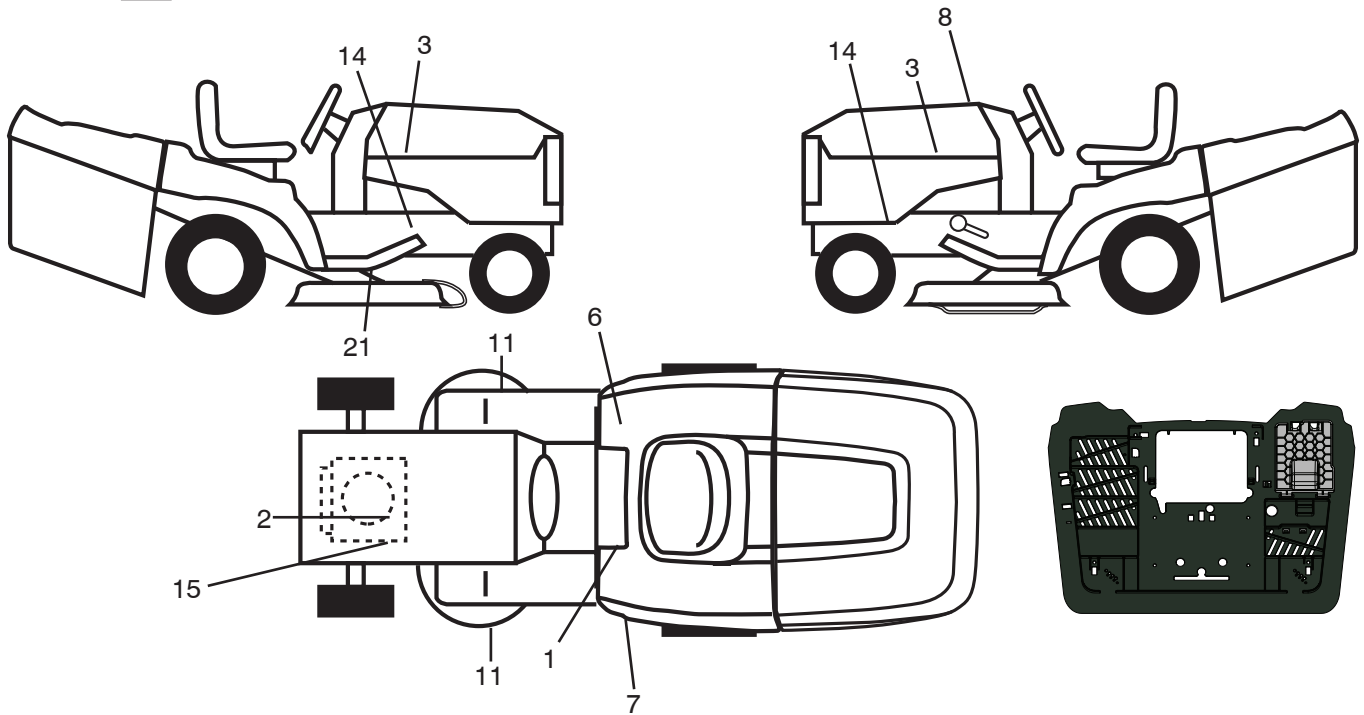

KEY NO.	PART NO.	DESCRIPTION
1	581 57 83-01	Decal, Warning
2	581 57 97-01	Decal, Warning Eng. Sym.
3	581 09 12-01	Decal, Hood RH/LH
6	581 72 41-01	Decal, 100 DB/CE
7	581 96 50-01	Decal, SDFNDR
8	581 59 24-01	Decal, Replacement
11	581 57 91-01	Decal, Cut Finger
14	581 57 96-01	Decal, Chassis Hot Muffler
15	581 25 90-01	Decal, Engine HP
21	532 44 11-89	Decal, Belt Sch CRD

KEY NO.	PART NO.	DESCRIPTION
--	583 90 19-01	Decal, Bypass
--	532 44 54-93	Decal, Warning Combined
--	532 44 51-02	Decal, Battery Door
--	532 42 59-86	Pad Footrest RH
--	532 42 59-76	Pad Footrest LH
--	581 96 10-40	Manual Operator's (Euro)
--	581 96 10-50	Manual Operator's (Scan)
--	581 96 10-20	Manual Operator's (E-Bloc)
--	581 96 10-30	Manual Operator's (Baltic)

WHEELS & TIRES

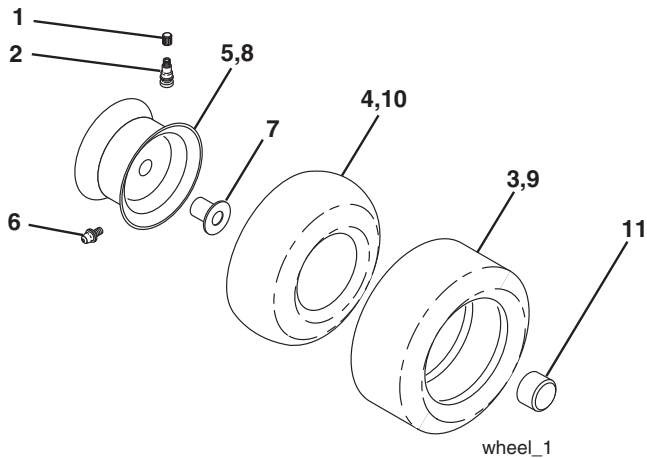

KEY NO.	PART NO.	DESCRIPTION
1	532 05 91-92	Cap Valve Tire
2	532 06 51-39	Stem Valve
3	532 10 62-22	Tire F Ts 15 x 6 0 - 6 Service
4	532 05 99-04	Tube Inner Front #35060
5	532 12 51-21	Rim Asm 6" Front Silver Service
6	532 12 49-57	Fitting Grease
7	532 12 49-59	Bearing Flange
8	532 12 51-22	Rim Asm 8" Rear Silver Service
9	532 42 05-31	Tire R.Ts-LT 18 x 9.5-8 C Ser.
10	532 12 49-26	Tube Rear 9 5 x 8 Service
11	532 19 32-68	Cap Axle
--	532 14 43-34	Sealant, Tire (10 oz. Tube)

NOTE: All component dimensions given in U.S. inches
1 inch = 25.4 mm

TRACTOR - MODEL NO. M200-107TC (96051006800), PROD. NO. 960 51 00-68

SCHEMATIC **38**

SCH17

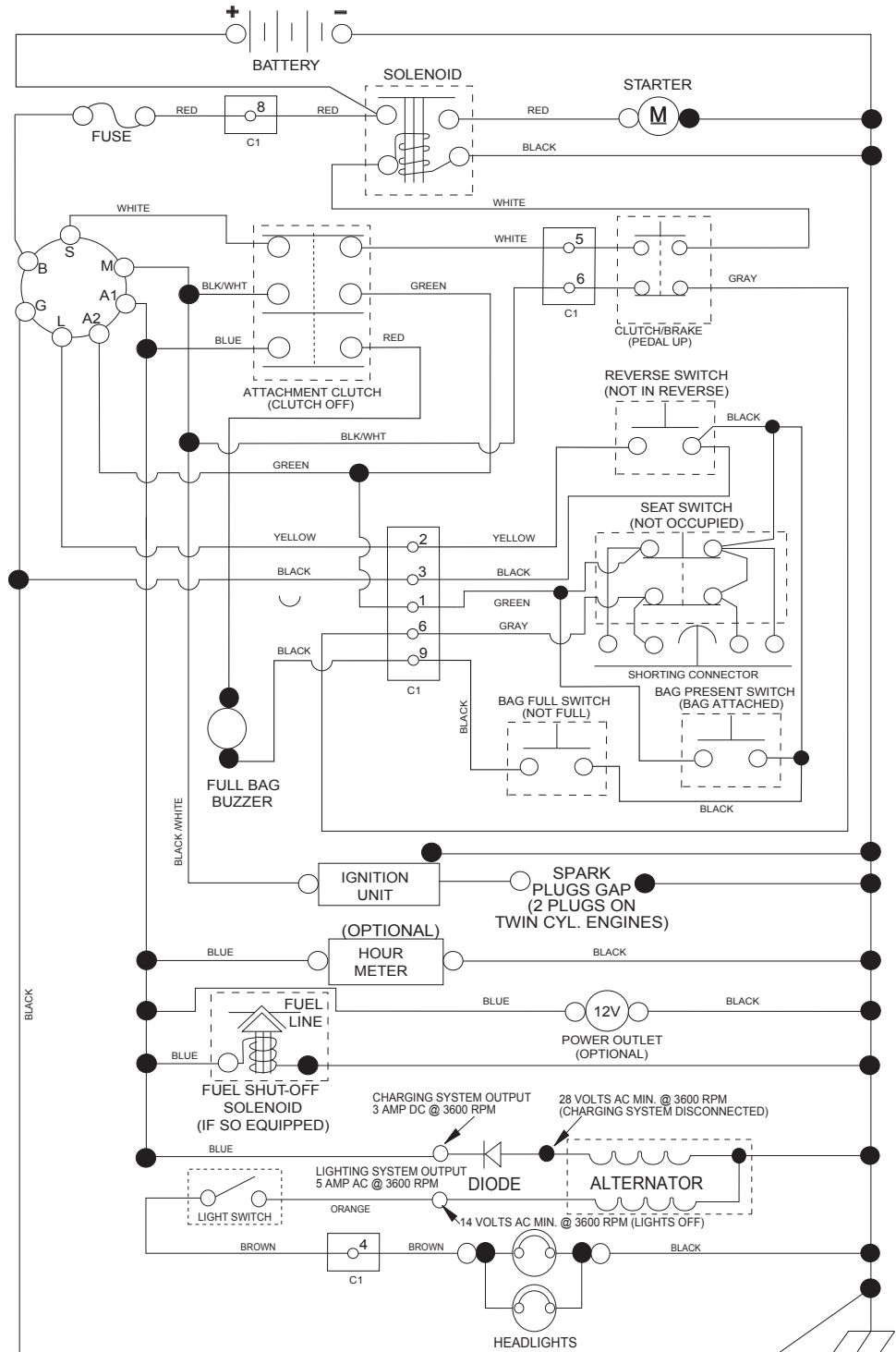

NOTE
YOUR TRACTOR IS EQUIPPED WITH A SPECIAL ALTERNATOR SYSTEM. THE LIGHTS ARE NOT CONNECTED TO THE BATTERY, BUT HAVE THEIR OWN ELECTRICAL SOURCE. BECAUSE OF THIS, THE BRIGHTNESS OF THE LIGHTS WILL CHANGE WITH ENGINE SPEED. AT IDLE THE LIGHTS WILL DIM. AS THE ENGINE SPEED IS INCREASED, THE LIGHTS WILL BECOME THEIR BRIGHTEST.



IGNITION SWITCH

POSITION	CIRCUIT	"MAKE"
OFF	M+G+A1	
RUN/OVERRIDE	B+A1	
RUN	B+A1	L+A2
START	B + S + A1	



CHASSIS HARNESS CONNECTOR (C1) (MATING SIDE)



DASH HARNESS CONNECTOR (C1) (MATING SIDE)

WIRING INSULATED CLIPS
NOTE: IF WIRING INSULATED CLIPS WERE REMOVED FOR SERVICING OF UNIT, THEY SHOULD BE RE-INSTALLED TO PROPERLY SECURE YOUR WIRING.

NON-REMOVABLE CONNECTIONS
REMOVABLE CONNECTIONS

TRACTOR - MODEL NO. M200-107TC (96051006800), PROD. NO. 960 51 00-68
ELECTRICAL 32

KEY NO.	PART NO.	DESCRIPTION
1	532 43 71-57	Battery
2	532 44 09-23	Screw Hex Hd Cap M6 x 1.12mm
16	532 17 61-38	Switch Interlock
21	532 40 02-52	Harness Asm Light w/4152J
22	532 00 41-52	Bulb Light #1156
25	532 44 13-82	Cable Battery Red
26	532 17 51-58	Fuse
27	873 51 04-00	Nut Keps Hex 1/4-20 unc
28	532 44 13-83	Cable Ground Black
29	532 40 15-45	Switch Seat
30	532 19 33-50	Switch Ignition
33	532 41 19-35	Key/Chain
34	532 11 07-12	Switch Light
40	532 42 10-02	Harness Ignition Dash
43	532 19 25-07	Solenoid
55	817 06 05-12	Screw 5/16-18 x 3/4
71	581 02 33-01	Harness Chassis
79	532 17 52-42	Socket Asm.
83	532 43 67-74	Nut Square M6 x 1 x 8.5 x 11mm
87	532 42 10-60	Switch Railmount
99	817 72 04-08	Screw 1/4-20 x 1/2
102	581 02 35-01	Harness Pigtail
105	532 40 75-68	Switch Reverse
107	532 18 03-79	Switch Full Bagger Indicator
108	532 42 10-62	Switch Snapmount

NOTE: All component dimensions given in U.S. inches
1 inch = 25.4 mm

TRACTOR - MODEL NO. M200-107TC (96051006800), PROD. NO. 960 51 00-68
CHASSIS AND ENCLOSURES **39**

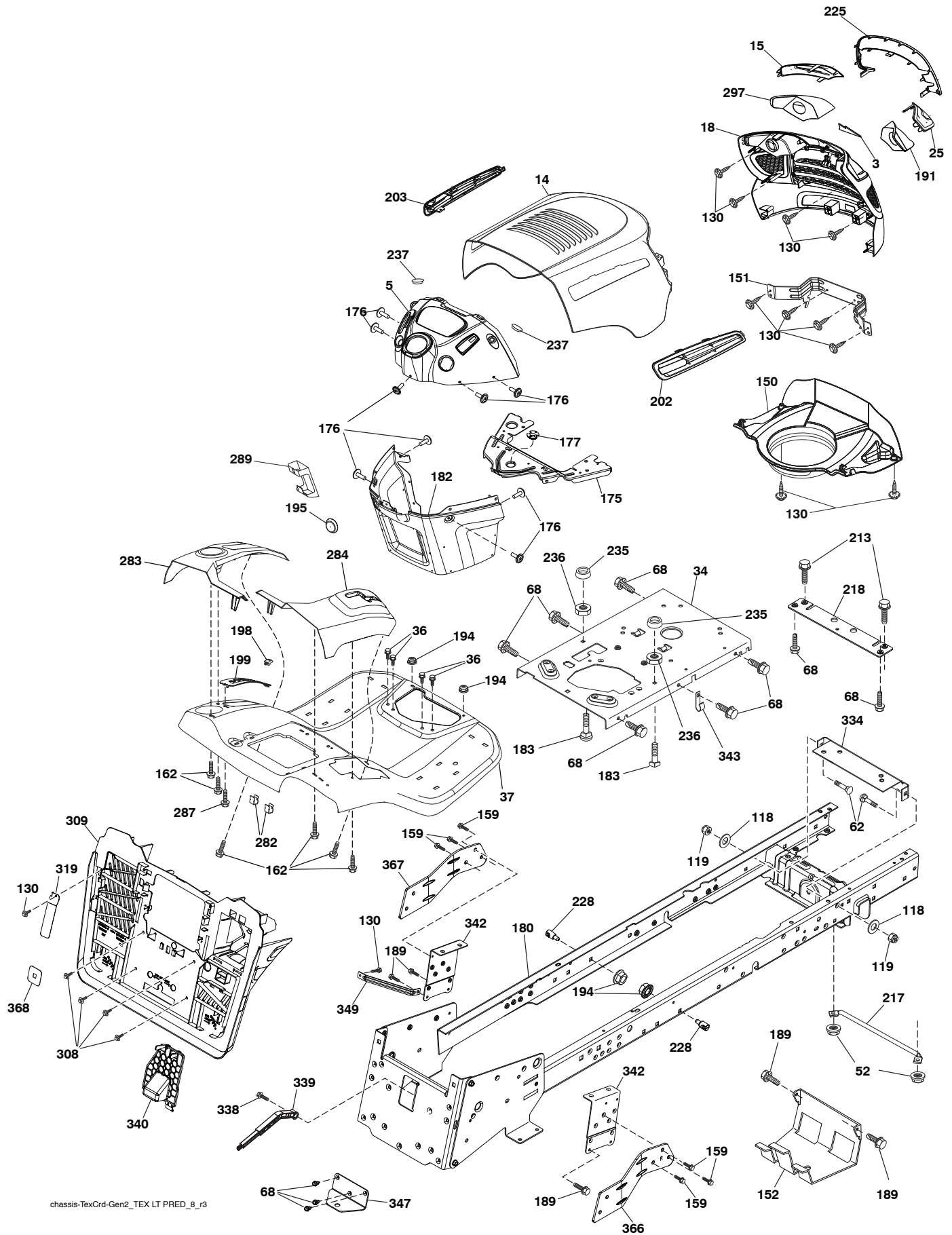

chassis-TexCrd-Gen2_TEX LT PRED_8_r3

**TRACTOR - MODEL NO. M200-107TC (96051006800), PROD. NO. 960 51 00-68
CHASSIS AND ENCLOSURES 39**

KEY NO.	PART NO.	DESCRIPTION	KEY NO.	PART NO.	DESCRIPTION
3	578 89 71-01	Emblem Mount	217	532 40 91-67	Rod Pivot Hood
5	532 44 18-82	Dash	218	532 19 63-95	X-Piece Hood Stop
14	532 44 80-42	Hood	225	581 10 32-01	Trim Ring
15	581 10 31-01	Lens LH	228	532 19 51-61	Stud Fastener
18	581 10 29-01	Grille	235	532 40 61-29	Spacer Fender
25	581 10 30-01	Lens RH	236	873 93 05-00	Nut Lock 5/16-18 unc
34	580 91 09-01	Plate Engine	237	532 40 37-04	Plug Mount Cargo
36	817 06 05-12	Screw 5/16-18 x 3/4	282	532 41 41-10	Clip Retainer
37	532 43 96-24	Fender	283	532 44 76-71	Console Deck Lift
52	873 68 05-00	Nut Crown Lock 5/16	284	532 44 76-72	Console Shift RH
62	872 11 06-08	Bolt 3/8-16 x 1 Gr. 5	287	817 60 04-06	Screw Hex Washhead 1/4-20 x 3/8
68	817 49 05-08	Screw Thdrol. 5/16-18 x 1/2	289	532 40 35-71	Plug Cruise/Phone
118	819 13 13-16	Washer 13/32 x 13/16 x 16 Ga.	297	581 22 36-01	Insert Reflective LH
119	873 68 06-00	Nut 3/8-16 unc	308	532 17 18-77	Bolt 5/16-18 unc x 3/4
130	532 41 63-58	Screw #10 x 0.750 BOS Thread	309	581 32 89-07	Backplate Bagger
150	584 86 29-01	Duct, Air	319	581 31 39-06	Lever Bagger
151	532 44 54-94	Bracket Pivot Hood	334	532 44 25-37	Engine Plate
152	532 19 95-35	Shield Browning	338	532 43 66-40	Bolt Shoulder
159	817 00 06-12	Screw Hexwsh Thdr 3/8-16 x 3/4	339	532 43 66-41	Lever Bagger Full
162	532 14 24-32	Screw Hex Wsh. Hi-Lo 1/4 x 1/2 unc	340	581 32 90-01	Door Battery
175	532 19 63-04	Crossmember	342	532 43 59-38	Support Fender
176	532 40 07-76	Screw 10-24 x 5/8	343	532 44 07-49	Clip
177	532 19 52-27	Bushing Steering	347	532 44 58-32	Hitch
180	532 44 28-92	Chassis	349	532 43 66-06	Bracket, Support
182	532 40 68-59	Dash Lower	366	581 31 46-02	Bracket RH Front Bagger
183	874 52 05-20	Bolt 5/16-18 x 1-1/4	367	581 31 45-02	Bracket LH Front Bagger
189	817 00 05-12	Screw 5/16-18 x 3/4	368	581 42 48-01	Full Lever Bagger
191	581 22 35-01	Insert Reflective RH	--	532 44 11-26	Plug Dash
194	873 90 05-00	Nut Lock Hex Flange 5/16-18	--	532 40 09-44	Bumper
195	532 40 15-56	Plug 12V Adapter			
198	532 44 80-48	Indicator Deck Lift			
199	532 41 87-39	Plate Deck Lift			
202	581 85 91-01	Vent Hood RH			
203	581 85 92-01	Vent Hood LH			
213	874 76 05-12	Bolt 5/16-18 x 3/4			

NOTE: All component dimensions given in U.S. inches
1 inch = 25.4 mm

TRACTOR - MODEL NO. M200-107TC (96051006800), PROD. NO. 960 51 00-68
DRIVE **40**

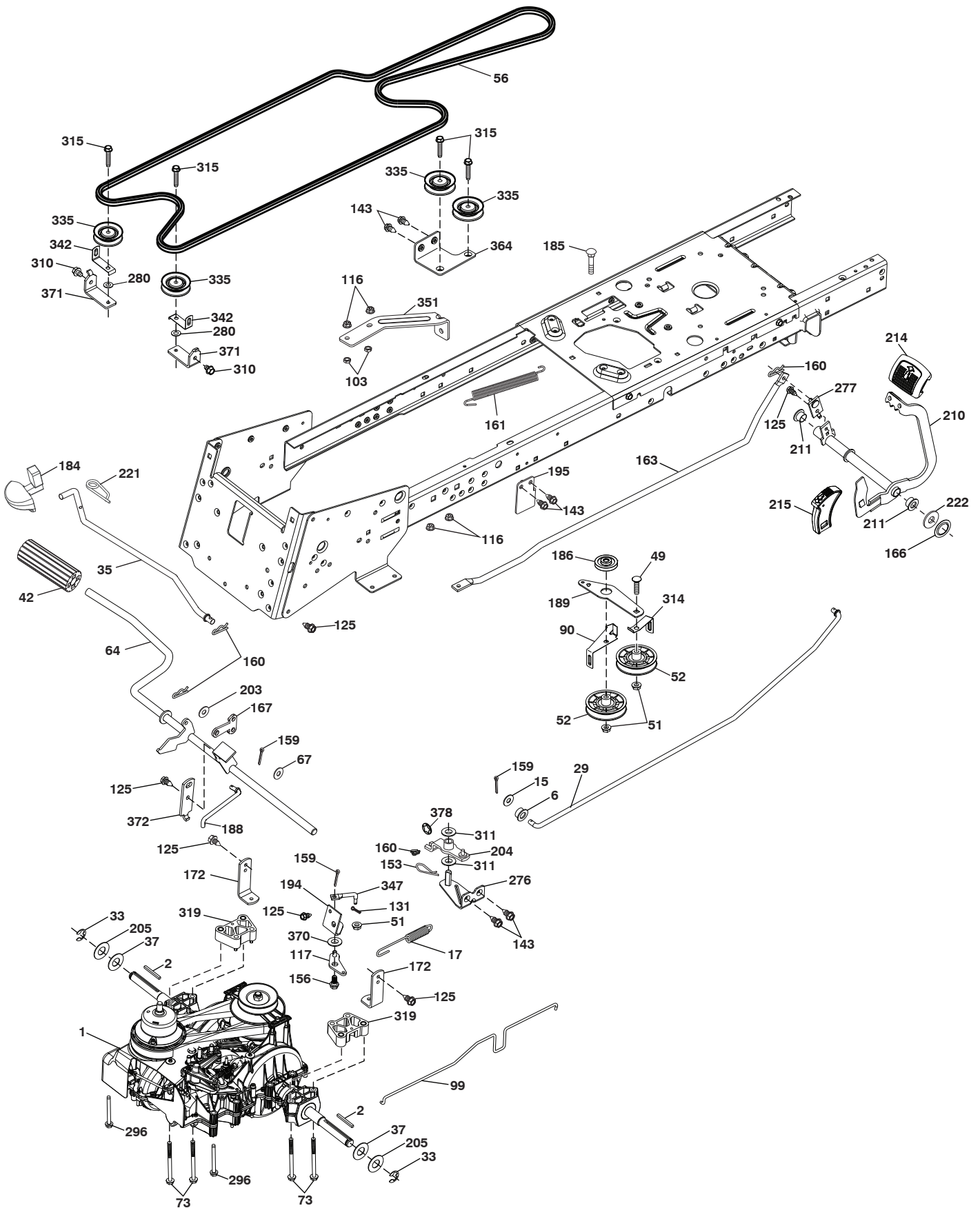

**TRACTOR - MODEL NO. M200-107TC (96051006800), PROD. NO. 960 51 00-68
DRIVE 40**

KEY NO.	PART NO.	DESCRIPTION	KEY NO.	PART NO.	DESCRIPTION
1	-----	Transmission, Gentrans VATR. (580486401) (Order parts from transaxle manufacturer.)	188	532 19 43-23	Link Clutch Ground Drive
2	532 12 35-83	Key Square .2.0 x .1845/.1865	189	532 43 36-11	Bellcrank Groundrive
6	532 12 40-28	Bushing Snap	194	580 32 49-01	Bellcrank Brake
15	819 13 13-16	Washer 13/32 x 13/16 x 16 Ga.	195	580 45 69-01	Brake Bracket
17	580 32 52-01	Spring Brake	203	819 11 11-16	Washer 11/32 x 11/16 x 16 Ga.
29	581 50 35-01	Rod Brake	204	584 99 70-01	Link Pivot Pedal
33	812 00 00-01	E-Ring. #5133-75	205	532 12 17-48	Washer 25/32 x 1-5/8 x 16 Ga.
35	583 86 45-01	Rod Brake Parking. Lt.Tex	210	532 44 82-70	Weldment Pedal
37	532 18 89-67	Washer Harden .793 x 1.637 x 060	211	532 12 01-83	Bearing Nylon
42	532 12 48-72	Cover Pedal Blk Round	214	532 42 12-63	Pedal Forward Pad
49	872 11 06-14	Bolt Rdhd 3/8-16 Unc x 1-3/4.Gr 5	215	532 44 82-54	Cap Pedal Reverse
51	873 90 06-00	Nut, Hex, Flangelock 3/8-16	221	532 40 31-87	Retainer Spring Clip Handle
52	532 19 43-26	Idler V-Groove Offset	222	879 21 20-10	Washer 21/32 x 1-1/4 10 Ga.
56	532 44 69-91	Belt Drive	276	584 99 67-01	Bracket Control Pedal
64	532 44 83-53	Shaft Asm. Pedal Brake	277	532 44 85-00	Subasm. Link Rocker Pedal
67	819 13 13-12	Washer 13/32 x 13/16 x 12 Ga.	280	819 11 10-12	Washer 11/32 x 5/8 x 12 Ga.
73	580 83 04-01	Bolt Shoulder Transaxle	296	532 42 04-71	Screw Thdrol 5/16-18 x 3
90	532 44 36-05	Keeper Belt	310	817 49 06-08	Screw Thdrol 3/8-16 x 1/2
99	580 35 40-01	Rod Bypass	311	584 07 20-01	Washer Nylon
103	873 35 05-00	Nut Hex Jam 5/16-18 UNC	314	532 44 47-13	Keeper Belt
116	873 90 05-00	Nut, Lock Hex Flange 5/16-18 unc	315	817 58 05-20	Screw Thdrol 5/16-18 x 1.25
117	580 38 29-01	Subasm Bellcrank Brake	319	580 45 74-01	Spacer Transaxle
125	817 00 05-12	Screw 5/16-18 x 3/4 Smgml Tap/Bl	335	532 19 95-34	Pulley V-Idler
131	876 02 03-08	Pin Cotter 3/32 x 1/2	342	580 96 10-02	Keeper Belt Idler
143	817 49 05-08	Screw Thdrol 5/16-18 x 1/2 Tytt	347	580 32 51-01	Rod Connecting Brake
153	532 12 49-61	Retainer Clip	351	532 43 69-98	Bracket Swaybar
156	580 36 90-01	Bolt Shoulder Brake	364	532 44 30-32	Bracket Idler
159	876 02 04-12	Pin Cotter 1/8 x 3/4	370	878 12 16-32	Washer Thrust 3/8 x 1 x .032
160	532 16 94-84	Retainer Clip(M).Dia.290	371	580 96 07-02	Bracket Idler
161	532 10 57-09	Spring Return Clutch 6.75	372	581 47 52-01	Arm Control Brake
163	585 06 17-01	Rod Control Pedal	378	584 28 77-01	Nut Push
166	532 42 91-64	Nut Push .625			
167	532 40 52-57	Latch Brake Parking			
172	532 44 82-76	Strap Torque LH/RH			
184	532 44 14-55	Handle Parking Brake			
185	872 11 06-22	Bolt Rdhd.3/8-16 Unc x 2-3/4 Gr.5			
186	532 19 43-21	Spacer Retainer			

NOTE: All component dimensions given in U.S. inches
1 inch = 25.4 mm

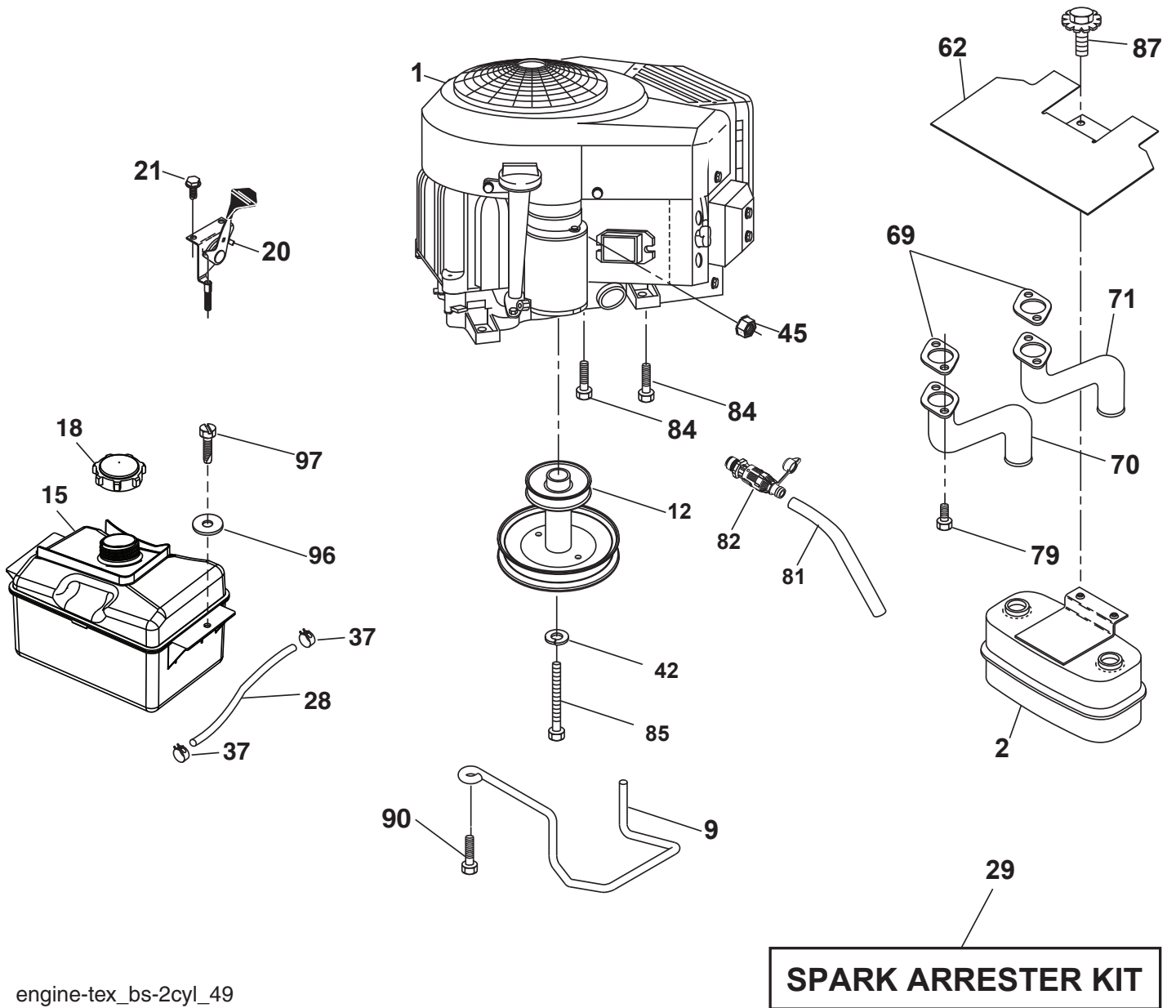

engine-tex_bs-2cyl_49

**TRACTOR - MODEL NO. M200-107TC (96051006800), PROD. NO. 960 51 00-68
ENGINE 24**

KEY NO.	PART NO.	DESCRIPTION
1	-----	Engine Briggs Model 406777-5271-B1 (581081701) (Order parts from engine manufacturer)
2	532 14 97-23	Muffler
9	581 47 82-01	Keeper Belt Engine
12	532 40 54-71	Pulley Engine
15	532 43 08-25	Tank Fuel
18	532 43 02-20	Cap Fuel
20	532 42 35-02	Control Throttle/Choke
21	532 41 63-58	Screw #10 x 0.750
28	532 13 70-40	Line Fuel
29	532 13 71-80	Kit Spark Arrester (Flat Scrn)
37	532 12 34-87	Clamp Hose Blk
42	810 04 07-00	Washer Lock 7/16
45	873 51-04-00	Nut Keps Hex 1/4-20 unc
62	532 43 40-17	Shield Heat Muffler
69	532 16 52-91	Gasket Muffler
70	581 88 11-01	Exhaust Tube LH
71	581 88 10-01	Exhaust Tube RH
79	532 18 39-06	Screw
81	532 14 84-56	Tube Drain
82	532 42 82-87	Valve Oil Drain
84	817 06 06-20	Screw 3/8-16 x 1-1/4
85	532 17 39-37	Bolt 7/16-20 x 4 x Gr. 5-1.5 THR
87	532 17 18-77	Bolt 5/16-18 unc x 3/4
90	817 00 06-16	Screw 3/8-16 x 1
96	819 09 14-16	Washer 9/32 x 7/8 x 16 Ga.
97	817 67 04-12	Screw Hexwsh Thdrol 1/4-20 x 3/4

NOTE: All component dimensions given in U.S. inches
1 inch = 25.4 mm

Engine Power Rating Information

The gross power rating for individual gas engine models is labeled in accordance with SAE (Society of Automotive Engineers) code J1940 (Small Engine Power & Torque Rating Procedure), and rating performance has been obtained and corrected in accordance with SAE J1995 (Revision 2002-05). Torque values are derived at 3060 RPM; horsepower values are derived at 3600 RPM. Actual gross engine power will be lower and is affected by, among other things, ambient operating conditions and engine-to-engine variability. Given both the wide array of products on which engines are placed and the variety of environmental issues applicable to operating the equipment, the gas engine will not develop the rated gross power when used in a given piece of power equipment (actual "on-site" or net power). This difference is due to a variety of factors including, but not limited to, accessories (air cleaner, exhaust, charging, cooling, carburetor, fuel pump, etc.), application limitations, ambient operating conditions (temperature, humidity, altitude), and engine-to-engine variability. Due to manufacturing and capacity limitations, Briggs & Stratton may substitute an engine of higher rated power for this Series engine.

TRACTOR - MODEL NO. M200-107TC (96051006800), PROD. NO. 960 51 00-68
STEERING ASSEMBLY [41]

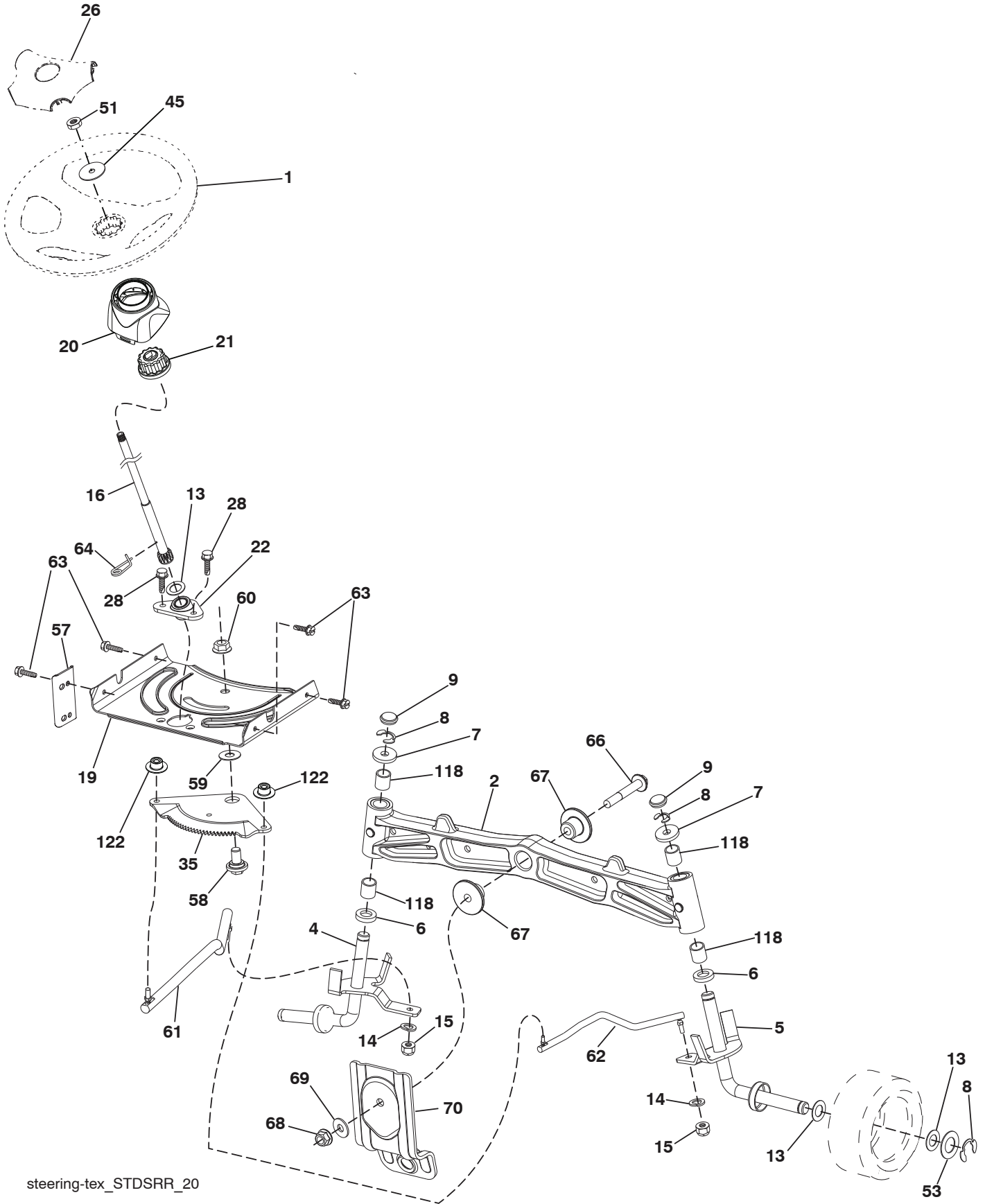

steering-tex_STDSRR_20

**TRACTOR - MODEL NO. M200-107TC (96051006800), PROD. NO. 960 51 00-68
STEERING ASSEMBLY **41****

KEY NO.	PART NO.	DESCRIPTION
1	532 44 28-04	Wheel, Steering
2	532 41 35-91	Axle Asm., Front
4	532 40 30-87	Spindle Asm., LH
5	532 40 30-88	Spindle Asm., RH
6	532 12 49-31	Bearing, Race Thrust Harden
7	532 12 17-48	Washer 25/32 x 1-5/8 x 16 Ga.
8	812 00 00-29	Ring, Klip #T5304-75
9	532 12 12-32	Cap, Spindle
13	532 12 17-49	Washer 25/32 x 1-1/4 x 16 Ga.
14	810 04 06-00	Washer, Lock Hvy Hlcl Spr 3/8
15	873 54 06-00	Nut, Crown Lock 3/8-24 unf
16	532 19 47-46	Shaft Steering
19	532 19 47-29	Plate Steering
20	532 42 47-40	Boot, Steering
21	532 18 67-37	Adapter, Wheel Steering
22	532 42 05-37	Strg. Supt. Lower
26	532 44 77-59	Insert, Wheel Steering
28	817 00 06-12	Screw 3/8-16 x 3/4
35	532 19 47-32	Gear, Sector Plate
45	819 18 38-12	Washer 9/16ID x 2-3/8OD.12
51	873 94 08-00	Nut Hex Jam
53	532 18 89-67	Washer Hardened .793 x 1.637 x .060
57	532 40 74-65	Bracket Upstop
58	532 19 47-47	Bolt Shoulder Sector Pivot CFM
59	532 19 47-48	Washer Thrust Sector Steering
60	873 97 10-00	Nut Flange Lock 5/8-11
61	532 19 47-40	Draglink, LH
62	532 19 47-41	Draglink, RH
63	817 00 05-12	Screw 5/16-18 x 3/4
64	532 19 98-49	Retainer Clip Spring Steering
66	871 02 07-48	Bolt Hex Fghd 7/16-14 x 3 Serr
67	532 19 47-37	Bushing PM Front Axle
68	873 90 07-00	Nut Lock Flange 7/16-14 Gr. 5
69	532 19 91-62	Washer 1.5 x .505 x .118
70	532 19 61-97	Bracket Deck Susp. Front
118	532 40 60-13	Bushing
122	532 44 49-62	Cap Gear Sector

NOTE: All component dimensions given in U.S. inches
1 inch = 25.4 mm

TRACTOR - MODEL NO. M200-107TC (96051006800), PROD. NO. 960 51 00-68
MOWER DECK 44

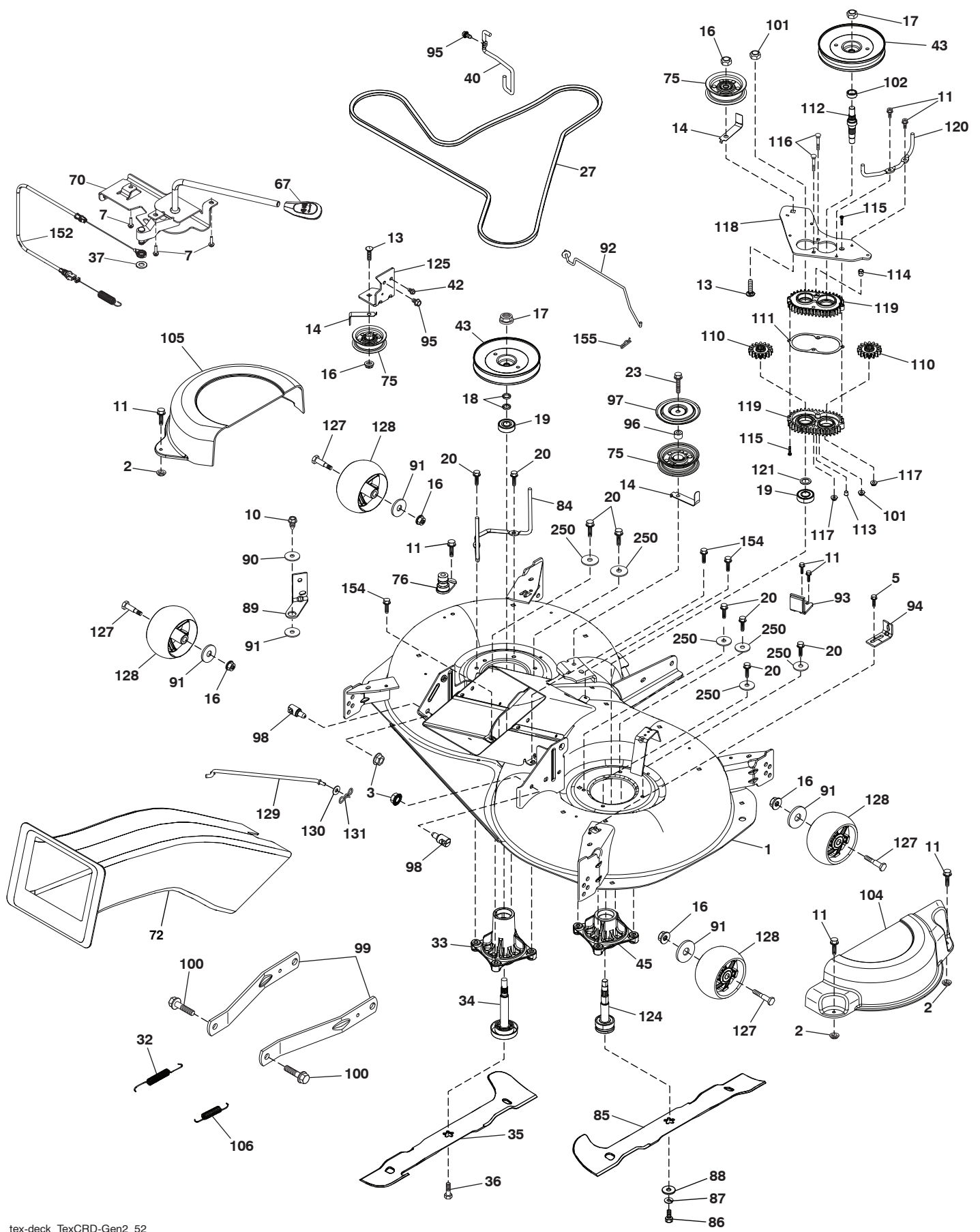

TRACTOR - MODEL NO. M200-107TC (96051006800), PROD. NO. 960 51 00-68
MOWER DECK 44

KEY NO.	PART NO.	DESCRIPTION	KEY NO.	PART NO.	DESCRIPTION
1	532 44 77-36	Deck Weldment	98	532 19 51-61	Stud Fastener
2	532 42 30-62	Pal Nut	99	532 19 51-86	Arm Suspension Mower Rear
3	873 90 05-00	Nut Lock Hex Flange 5/16 - 18	100	532 19 65-39	Bolt Shoulder
5	817 00 05-10	Bolt 5/16-18	101	873 68 09-00	Nut Crownlock 9/16 - 18 unc
7	532 41 63-58	Screw #10 x 0.750 BOS Thread	102	532 40 25-11	Spacer Bearing Swing Plate
10	817 00 06-16	Screw 3/8-16x1 smgml tap	104	581 71 40-01	Mandrel Cover RH
11	532 13 77-29	Screw Thd Roll 1/4 - 20 X 5/8	105	532 44 47-55	Mandrel Cover LH
13	872 11 06-12	Bolt Carr Sh 3/8 - 16 X 1-1/2 Gr. 5	106	532 19 32-16	Spring Brake Return
14	532 15 60-85	Keeper Belt Idler	110	532 41 53-56	Gear Output
16	873 90 06-00	Nut Lock FIG 3/8 - 16 unc	111	532 43 69-79	Gasket Gearcase
17	532 40 02-34	Nut Flange Lock Top	112	532 44 38-52	Shaft Gearcase Adapter
18	532 18 76-90	Washer Spacer Mandrel	113	532 43 85-33	Plug Oil
19	532 11 04-85	Bearing Ball Mandrel	114	532 43 85-34	Valve Relief
20	532 17 39-84	Screw Thread Roll	115	818 03 10-16	Screw Torx #10-24 x 1
23	817 49 06-28	Screw Thdrol 3/8 - 16 X 1-3/4	116	872 11 04-14	Bolt 1/4-20 x 1.75 Gr. 5
27	532 44 58-80	V-Belt Drive	117	873 90 04-00	Nut Hex Flange 1/4-20 unc
32	532 40 18-72	Spring Return Deck	118	532 44 32-32	Arm Clutching
33	580 79 61-01	Housing Mandrel 4pt Service	119	532 43 81-66	Gearcase Subasm
34	580 85 47-01	Shaft Asm Mndrl N/Greaseable38	120	532 44 32-36	Keeper Belt RH
35	581 51 79-01	Blade Mower LH	121	532 43 69-85	Washer
36	532 19 30-03	Bolt/Washer Asm 7/16 - 20 unf	124	581 65 07-01	Non Greasable Mandrel Shaft
37	819 13 13-16	Washer 13/32 x 13/16 x 16 Ga.	125	532 44 04-20	Bracket Idler Chassis
40	532 19 72-58	Keeper Belt Engine LH	127	532 19 34-06	Bolt Shoulder 3/8-16 x 3-5/8 Gr. 5
42	817 00 05-12	Screw 5/16-18 x 3/4	128	532 17 48-73	Wheel Gauge
43	532 44 32-39	Pulley Mandrel	129	532 44 32-37	Rod Anti-Sway
45	581 65 08-01	Housing Mandrel	130	819 13 13-12	Washer 13/32 x 13/16 x 12 Ga.
67	532 40 30-12	Handle Clutch Cable	131	532 19 42-08	Pin Cotter 5/16 Bow Tie Lock
70	532 19 99-72	Clutch Asm Manual LT Pred	152	532 44 76-66	Cable Clutch Manual w/Spring
72	581 45 41-01	Chute Upper	154	532 19 98-55	Screw Thd Roll 1/4-20 x 1/2
75	532 13 14-94	Pulley Idler Flat	155	532 12 47-88	Retainer Spring 1"
76	532 41 55-98	Washout Port	250	819 11 12-12	Washer 11/32 x 3/4 x 12 Ga.
84	532 44 32-35	Keeper Belt LH Mandrel	--	580 85 60-01	Mandrel Asm. Tall (Includes Housing (key#33), Shaft Assembly (key#34) and Bearing Only (key#19) - Pulley/Nut/Washer And Blade Bolt/Washers Not Included)
85	581 51 80-01	Blade Mower RH	--	581 65 05-01	Mandrel Asm. Short (Includes Housing (key#45), Shaft Assembly (key#124) and Bearing Only (key#19) - Pulley/Nut/Washer And Blade Bolt/Washers Not Included)
86	532 18 17-13	Bolt 3/8-24 x 1.50 Gr. 8	--	583 90 34-01	Replacement Mower Complete
87	810 03 06-00	Washer Lock Hvy. 3/8			
88	532 14 02-96	Washer Hard			
89	532 19 72-61	Arm Brake 97 LH			
90	532 19 90-92	Spacer Retainer			
91	819 13 20-12	Washer 13/32 x 1-1/4 x 12 Ga.			
92	532 44 32-33	Rod Brake Assembly			
93	532 43 81-25	Arm Brake RH			
94	532 19 72-50	Bracket Clutch Cable			
95	817 00 06-12	Screw 3/8-16 x 3/4			
96	532 40 02-71	Spacer			
97	532 18 20-61	Shield Idler Mower			

NOTE: All component dimensions given in U.S. inches
1 inch = 25.4 mm

TRACTOR - MODEL NO. M200-107TC (96051006800), PROD. NO. 960 51 00-68
MOWER LIFT 45

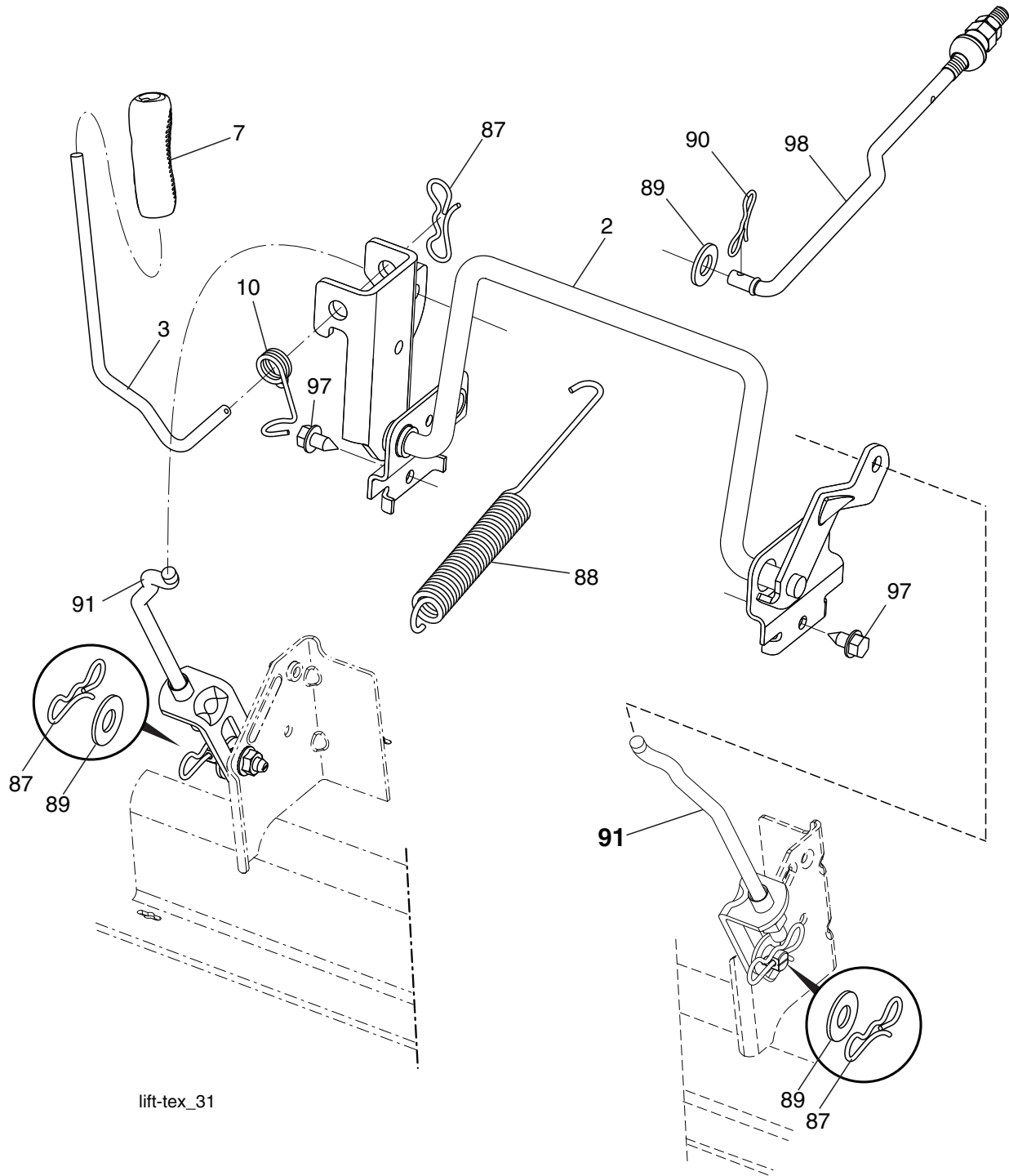

KEY NO.	PART NO.	DESCRIPTION
2	532 43 69-96	Deck Lift
3	532 19 52-31	Lever Asm., Lift RH
7	580 96 23-01	Grip, Lever
10	532 19 63-14	Spring Torsion
87	532 19 42-09	Pin Cotter 7/16 Bow Tie Lock
88	532 44 54-96	Spring Lift Assist
89	819 19 19-12	Washer 17/32 x 1-3/16 x 12 Ga.
90	532 19 42-08	Pin Cotter 5/16 Bow Tie Lock

KEY NO.	PART NO.	DESCRIPTION
91	532 19 51-81	Link Lift Susp Mower Rear
97	817 49 06-08	Screw 3/8-16 x 1/2
98	532 42 05-25	Link Lift Susp. Front Mower

NOTE: All component dimensions given in U.S. inches
 1 inch = 25.4 mm

TRACTOR - MODEL NO. M200-107TC (96051006800), PROD. NO. 960 51 00-68
SEAT ASSEMBLY 42

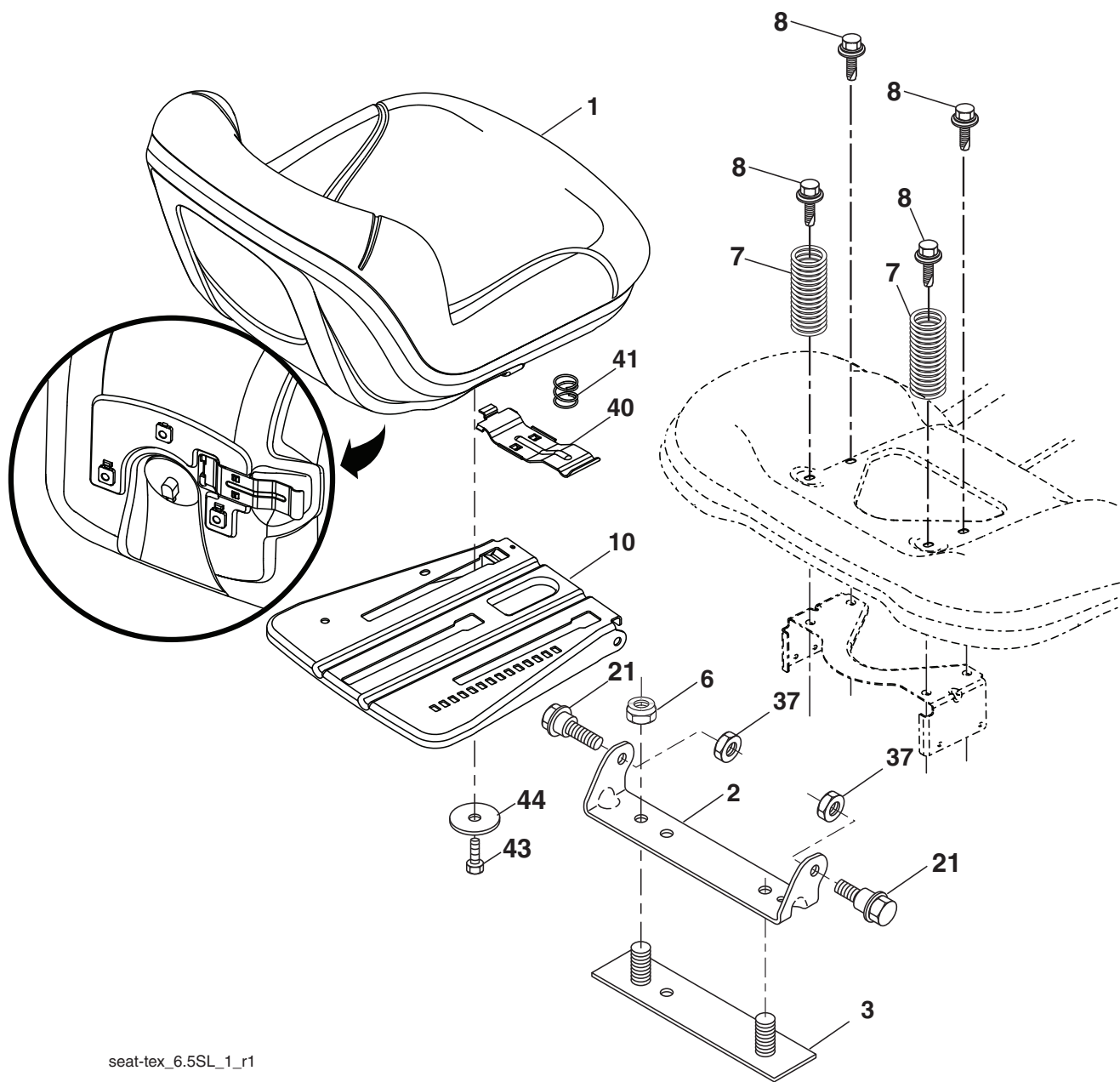

seat-tex_6.5SL_1_r1

KEY NO.	PART NO.	DESCRIPTION
1	581 46 21-01	Seat
2	532 18 01-66	Bracket Pnt Pivot Fender
3	532 14 06-75	Strap
6	873 80 06-00	Nut Lock Hex w/Ins 3/8-16
7	532 12 41-81	Spring Seat Cprsn 2 250 Blk Zi
8	532 17 18-77	Bolt 5/16-18 unc x 3/4
10	532 19 69-77	Pan Pnt Seat
21	532 17 18-52	Bolt Shoulder 5/16-18 unc-2A

KEY NO.	PART NO.	DESCRIPTION
37	873 80 05-00	Nut Hex Lock w/Ins 5/16-18
40	532 19 76-61	Handle Slide
41	532 19 82-00	Spring Latch
43	874 76 06-12	Bolt 3/8-16 unc x 3/4
44	819 13 38-12	Washer 13/32 x 2-3/8 x 12 Ga.

NOTE: All component dimensions given in U.S. inches
 1 inch = 25.4 mm

TRACTOR - MODEL NO. M200-107TC (96051006800), PROD. NO. 960 51 00-68
BAGGER **46**

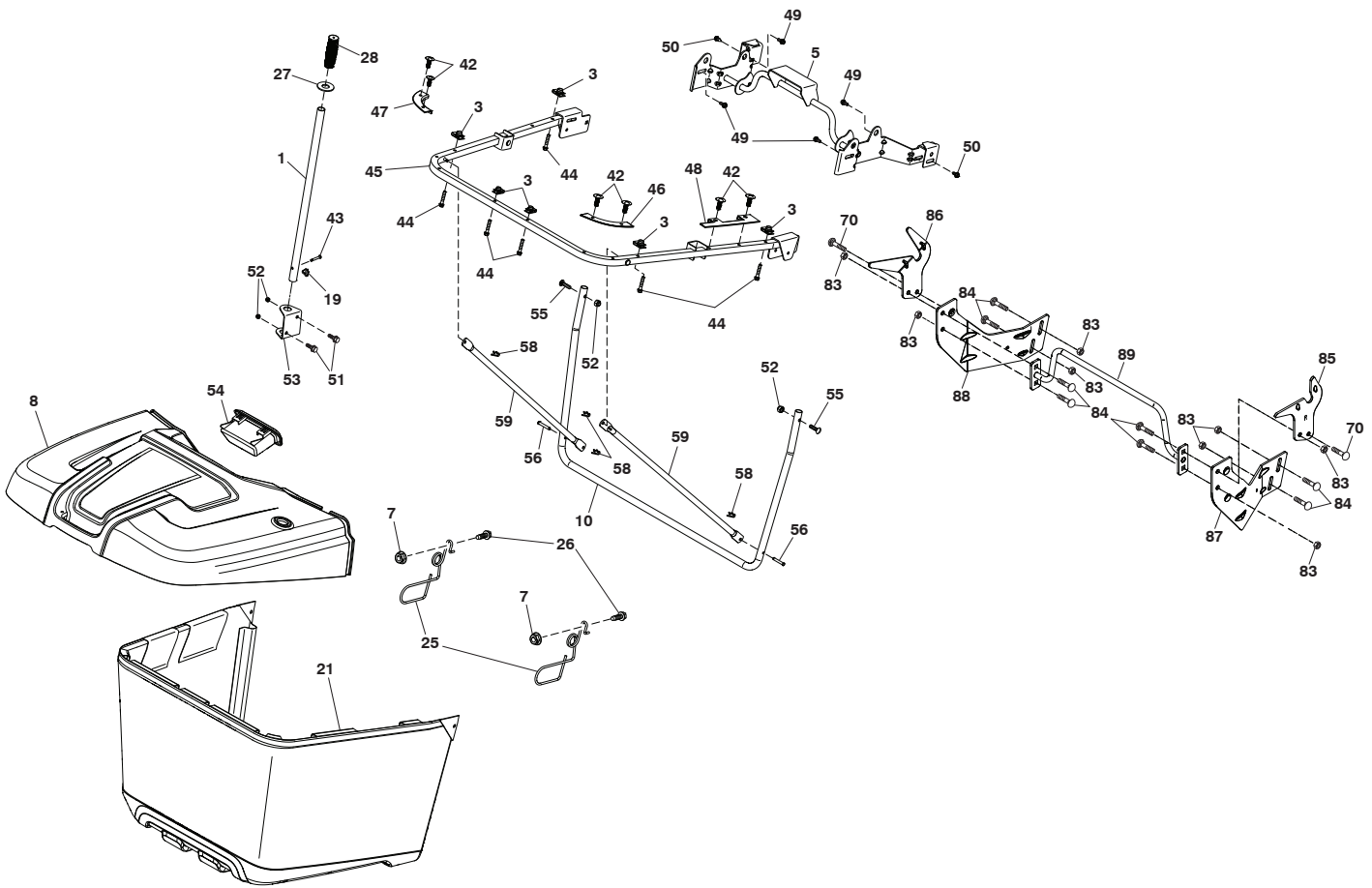

Bagger_TexCRD-Gen2_5_r2

**TRACTOR - MODEL NO. M200-107TC (96051006800), PROD. NO. 960 51 00-68
BAGGER 46**

KEY NO.	PART NO.	DESCRIPTION
1	532 42 86-10	Tube Handle Bagger
3	532 17 48-14	Nut Push
5	532 44 37-62	Frame Asm Top Bagger
7	873 90 04-00	Nut Hex Flange 1/4-20 unc
8	532 44 78-28	Cover Bagger
10	532 44 37-55	Frame Front
19	532 19 42-08	Cotter Pin 5/16 Bow Tie
21	581 33 71-01	Bag Asm
25	532 44 55-28	Latch Bagger
26	817 49 04-12	Screw Hexwsh Thdrol 1 1/4~20 x 3/4
27	532 44 55-29	Grommet Rubber
28	532 16 57-87	Grip Handle Black
42	532 44 04-28	Christmas Tree Clip
43	532 12 68-75	Clevis Pin
44	532 19 96-87	Bolt 1/4-20 1.50
45	532 44 37-54	Upper U Frame Weldment
46	532 44 55-41	Bagger Corner Close-Out RH
47	532 44 40-79	Bagger Corner Close-Out LH
48	532 44 40-80	Top Bagger Side Close-Out
49	532 17 18-73	Bolt Shoulder 5/16~ 18 TT
50	532 17 18-77	Bolt 5/16-18 unc x 3/4 W/SEMS
51	872 11 05-06	Bolt RDHDSQNK 5/16-18 unc x 3/4
52	873 80 05-00	Nut Lock HX W/INS 5/16-18 UNC
53	532 44 41-95	Bracket Dump Handle
54	532 44 75-43	Bagger TOP Front Handle
55	872 14 05-12	Bolt Rdhd Sq 5/16-18UNCX1 1/2
56	532 42 03-06	Pin Clevis .1830DX1.26 long
58	532 08 51-79	Clip Retainer PM
59	532 44 47-63	Bagger Spread Tube
70	817 00 06-12	Bolt 3/8-16X3/4
83	873 80 06-00	Nut Lock Hex w/Ins 3/8-16
84	872 11 06-08	Bolt RDHD SQNK 3/8-16 x 1 Gr. 5
85	581 31 44-02	Bracket RH Pivot
86	581 31 43-02	Bracket LH Pivot
87	581 31 48-02	Bracket RH
88	581 31 47-02	Bracket LH
89	581 31 51-02	Weldment Offset

NOTE: All component dimensions given in U.S. inches
1 inch = 25.4 mm

