

# **ILLUSTRATED PARTS LIST**

**MODEL NO. 96041029400**

**CUSTOMER CATALOG NO. M165-107T**

**PRODUCT NO. 960 41 02-94**

**TRACTOR -- MODEL NO. M165-107T (96041029400), PRODUCT NO. 960 41 02-94  
DECALS 27**

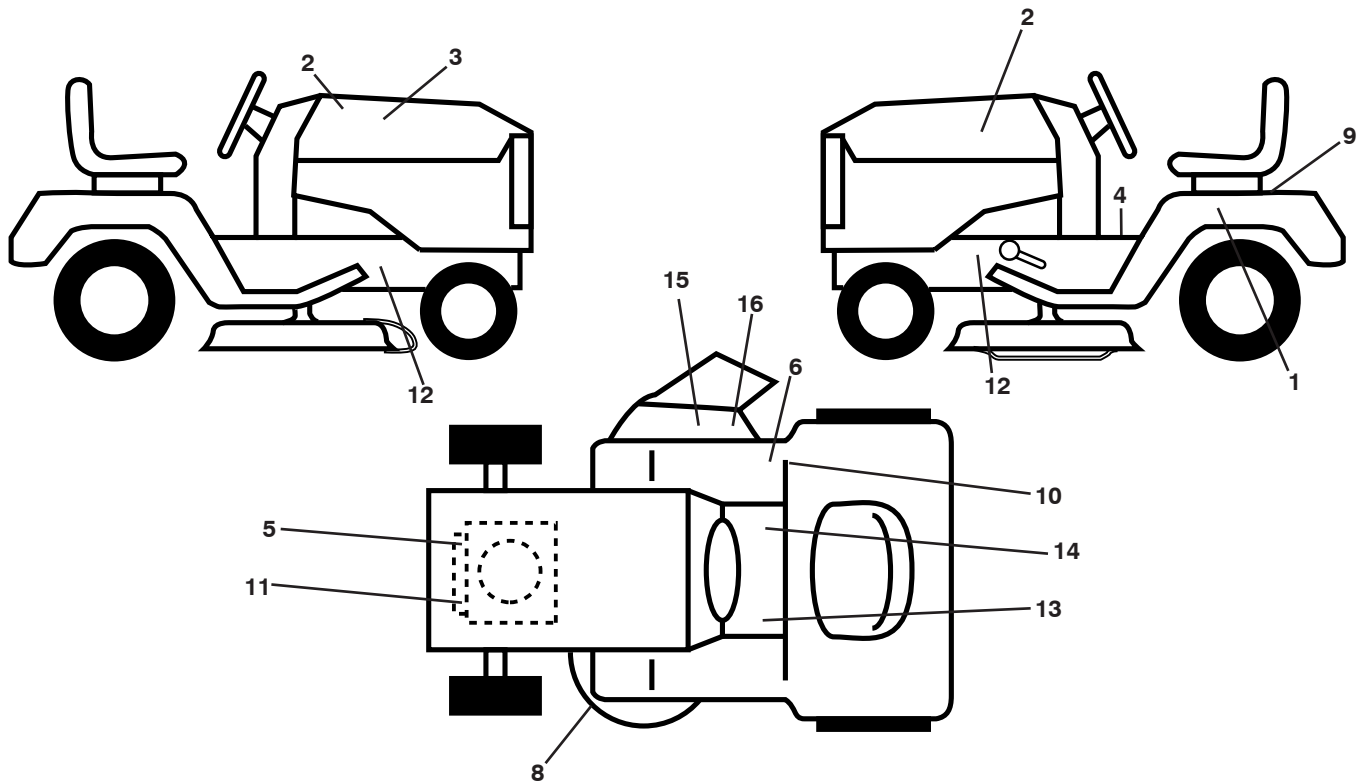

**KEY PART**

NO.	NO.	DESCRIPTION
1	581 95 31-01	Decal, Fender SD
2	581 09 12-01	Decal, Hood RH/LH
3	581 59 18-01	Decal, Replacement
4	581 57 81-01	Decal, Oper/Wrng.
5	532 43 74-15	Decal, Engine HP
6	581 57 86-01	Decal, Pedals
8	581 58 00-01	Decal, V-Belt Schematic
9	532 14 50-05	Decal, Battery Dan./Poi.
10	581 72 41-01	Decal, Fender 100 DB/CE
11	581 57 97-01	Decal, Warning Eng. Syms.
12	581 57 96-01	Decal, Chassis Hot Muffler
13	581 72 40-01	Decal, Brake/Clutch Sym.

**KEY PART**

NO.	NO.	DESCRIPTION
14	581 57 80-01	Decal, Saddle Brake Parking
15	581 57 91-01	Decal, Cutfinger CE
16	581 57 92-01	Decal, Deflect Wrn. Cutfinger Sym.
--	581 72 46-01	Decal, Drawbar Load Limit
--	581 72 48-01	Decal, Bypass
--	532 40 95-05	Pad, Footrest, LH
--	532 40 95-07	Pad, Footrest, RH
--	581 95 04-40	Manual, Operator's (Euro)
--	581 95 04-50	Manual, Operator's (Scan)
--	581 95 04-20	Manual, Operator's (Ebloc)
--	581 95 04-30	Manual, Operator's (Baltic)

**WHEELS AND TIRES**

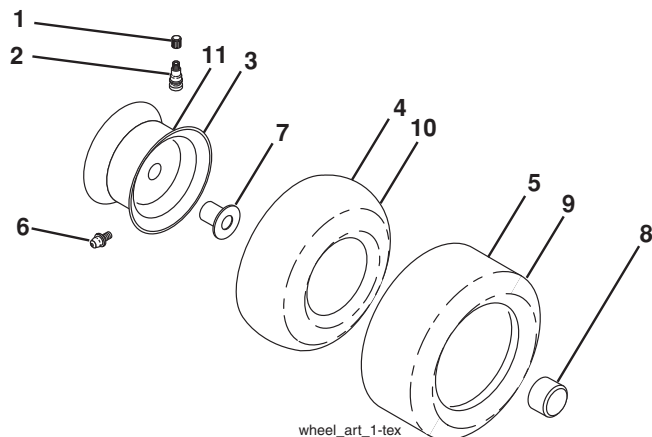

**KEY PART**

NO.	NO.	DESCRIPTION
1	532 05 91-92	Cap, Valve, Tire
2	532 06 51-39	Stem, Valve
3	532 12 51-21	Rim Assembly, Front
4	532 05 99-04	Tube, Front
5	532 10 62-22	Tire, Front
6	532 12 49-57	Fitting, Grease
7	532 12 49-59	Bearing, Flange
8	532 19 32-68	Cap, Axle
9	532 13 84-68	Tire, Rear
10	532 12 49-26	Tube, Rear
11	532 12 51-22	Rim Assembly, Rear
--	532 14 43-34	Sealant, Tire (10 Oz. Tube)

**NOTE:** All component dimensions given in U.S. inches  
1 inch = 25.4 mm

# TRACTOR - - MODEL NO. M165-107T (96041029400), PRODUCT NO. 960 41 02-94

## SCHEMATIC **38**

SCH11

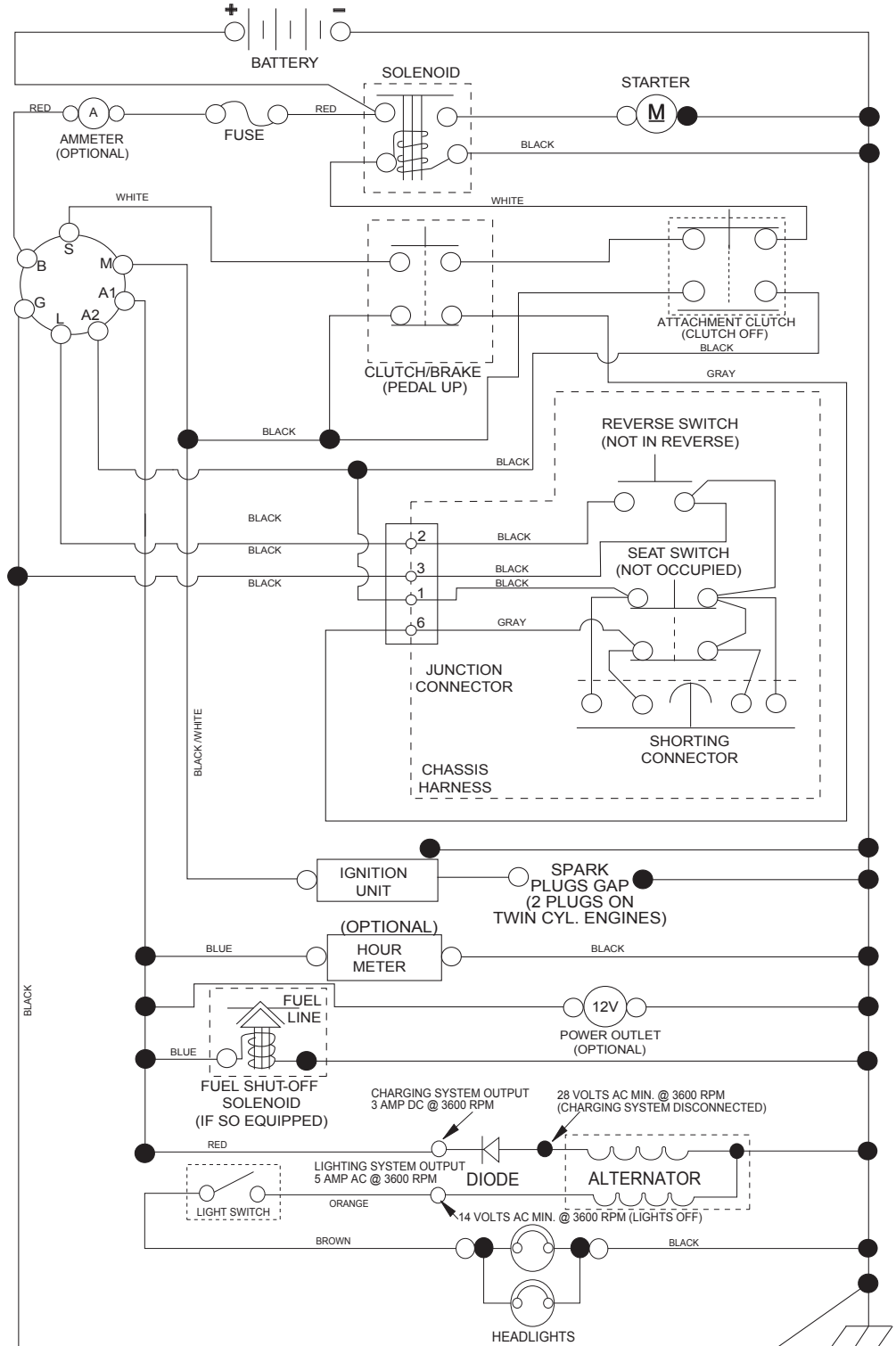

**NOTE**  
 YOUR TRACTOR IS EQUIPPED WITH A SPECIAL ALTERNATOR SYSTEM. THE LIGHTS ARE NOT CONNECTED TO THE BATTERY, BUT HAVE THEIR OWN ELECTRICAL SOURCE. BECAUSE OF THIS, THE BRIGHTNESS OF THE LIGHTS WILL CHANGE WITH ENGINE SPEED. AT IDLE THE LIGHTS WILL DIM. AS THE ENGINE IS SPEEDED UP, THE LIGHTS WILL BECOME THEIR BRIGHTEST.

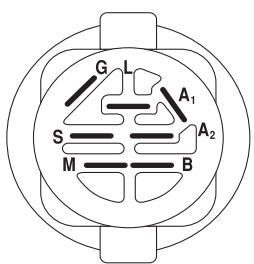

IGNITION SWITCH

POSITION	CIRCUIT "MAKE"
OFF	M+G+A1
RUN/OVERRIDE	B+A1
RUN	B+A1 L+A2
START	B + S + A1

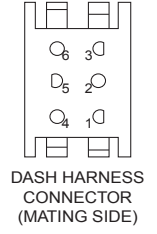
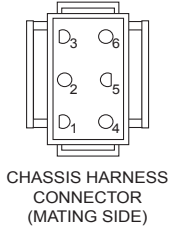

WIRING INSULATED CLIPS  
 NOTE: IF WIRING INSULATED CLIPS WERE REMOVED FOR SERVICING OF UNIT, THEY SHOULD BE RE-INSTALLED TO PROPERLY SECURE YOUR WIRING.

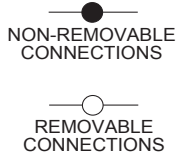

**TRACTOR -- MODEL NO. M165-107T (96041029400), PRODUCT NO. 960 41 02-94**  
**ELECTRICAL 32**

TR02K

With Service Minder Option

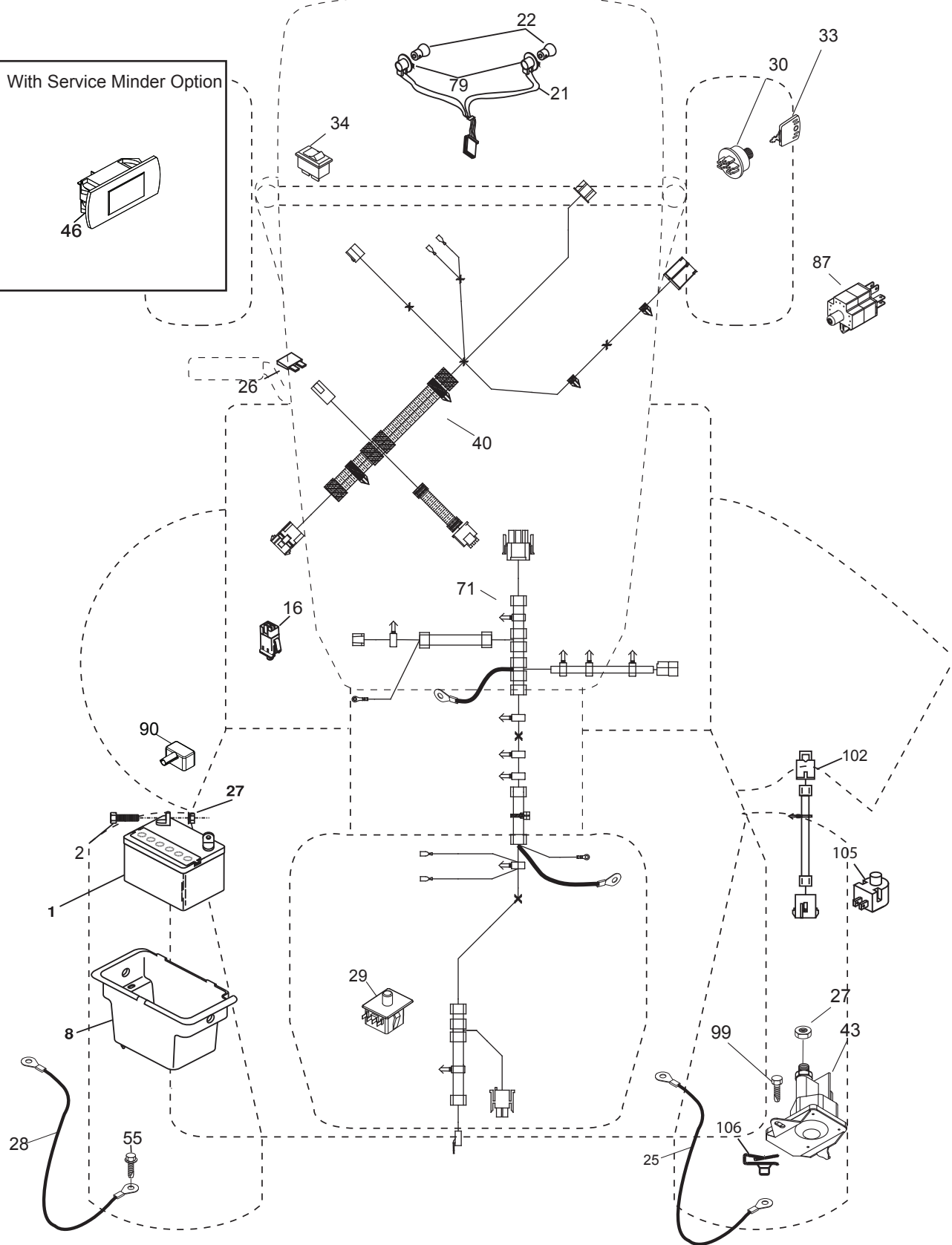
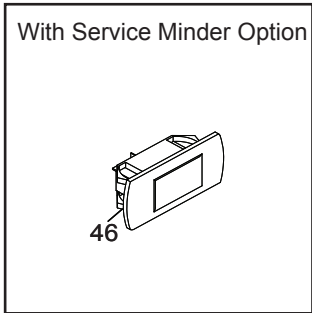

**TRACTOR - - MODEL NO. M165-107T (96041029400), PRODUCT NO. 960 41 02-94  
ELECTRICAL 32**

<b>KEY NO.</b>	<b>PART NO.</b>	<b>DESCRIPTION</b>
1	532 16 34-65	Battery
2	874 76 04-12	Bolt Hex Hd. 1/4-20 unc x 3/4
8	532 19 32-28	Box Battery
16	532 17 61-38	Switch Interlock Push-In
21	532 40 02-52	Harness Socket Light w/4152J
22	532 00 41-52	Bulb Light
25	581 49 80-01	Cable Starter
26	532 17 51-58	Fuse
27	873 51 04-00	Nut Keps Hex 1/4-20 unc
28	532 42 16-86	Cable, Ground
29	532 40 15-45	Switch, Seat
30	532 19 33-50	Switch, Ign.
33	532 41 19-35	Key/Chain
34	532 11 07-12	Switch Light/Reset
40	581 02 31-01	Harness Ign. Dash
43	532 19 25-07	Solenoid
55	817 06 05-12	Screw Thdrol. 5/16-18 x 3/4 TYTT
71	581 02 30-01	Harness Ign. Chassis
79	532 17 52-42	Bulbholder Asm. Incandescent
87	532 19 78-02	Switch Interlock Clutch
90	532 43 53-95	Cover Terminal Battery
99	817 67 04-12	Screw Hexwsh
102	581 02 34-01	Harness Pigtail
105	532 40 75-68	Switch Reverse
106	532 17 48-14	Palnut

**NOTE:** All component dimensions given in U.S. inches  
1 inch = 25.4 mm

TRACTOR - - MODEL NO. M165-107T (96041029400), PRODUCT NO. 960 41 02-94  
CHASSIS AND ENCLOSURES **39**

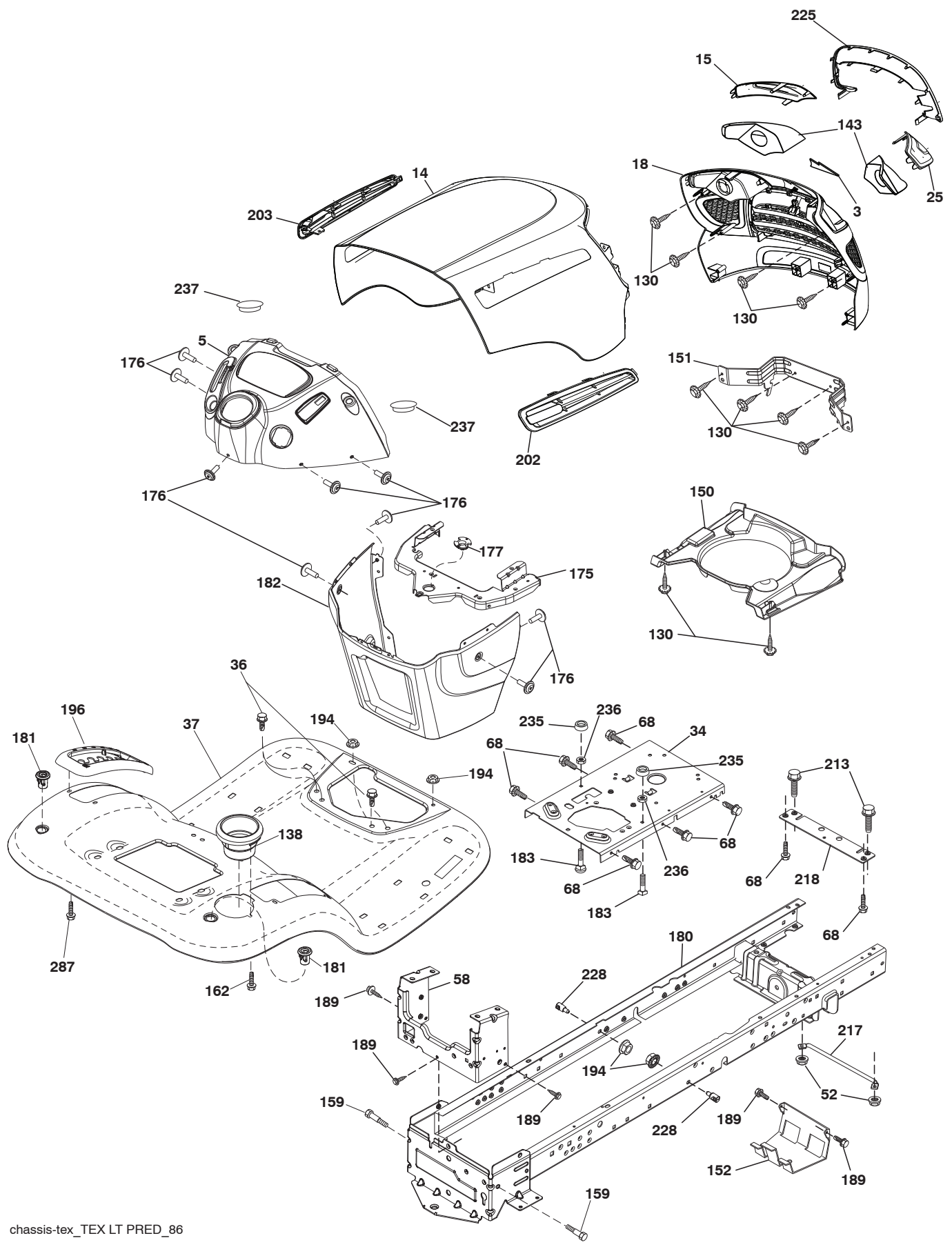

chassis-tex\_TEX LT PRED\_86

**TRACTOR - - MODEL NO. M165-107T (96041029400), PRODUCT NO. 960 41 02-94  
CHASSIS AND ENCLOSURES **39****

<b>KEY NO.</b>	<b>PART NO.</b>	<b>DESCRIPTION</b>
3	578 89 71-01	Emblem Mount
5	532 40 95-97	Dash
14	581 56 47-01	Hood
15	581 05 58-01	Lens LH
18	581 05 57-01	Grille
25	581 05 59-01	Lens RH
34	580 91 08-01	Plate Engine
36	817 06 05-12	Screw 5/16-18 x 3/4
37	532 42 07-96	Fender
52	873 68 05-00	Nut lock 5/16-18
58	532 41 22-80	Drawbar, Upper 2 Pc.
68	817 49 05-08	Screw Thdrol. 5/16-18 x 1/2
130	532 41 63-58	Screw #10 x 0.750
138	532 40 97-30	Cupholder
143	581 05 60-01	Relective RH/LH
150	532 40 02-67	Duct Heat Hood
151	532 18 75-68	Bracket Pivot
152	532 19 95-35	Shield Browning
159	817 00 06-12	Screw Hex Wsh. Thdrol. 3/8-16 x 3/4
162	532 14 24-32	Screw Hex Wsh. Hi-Lo 1/4 x 1/2
175	532 19 94-72	Crossmember
176	532 40 07-76	Screw 10-24 x 5/8 Wshd. Qdrx.
177	532 19 52-28	Bushing Steering
180	532 41 50-63	Chassis
181	532 40 47-96	Bushing Mtg. Fender Crgo.
182	532 40 71-76	Dash Lower
183	874 52 05-20	Bolt 5/16-18 x 1-1/4
189	817 00 05-12	Screw 5/16-18 x 3/4
194	873 90 05-00	Nut Lock Hex Flange 5/16-18
196	532 41 45-81	Console Asm. Deck Lift
202	581 56 49-01	Vent Hood RH
203	581 56 48-01	Vent Hood LH
213	874 76 05-12	Bolt Hex Hd. 5/16-18 unc x 3/4
217	532 40 91-67	Rod Pivot Chassis
218	532 19 63-95	X-Piece Hood Stop
225	581 05 62-01	Trim Ring
228	532 19 51-61	Stud Fastener
235	532 40 61-29	Spacer Fender
236	873 93 05-00	Nut center Lock 5/16-18
237	532 40 37-04	Plug Mount Cargo
287	817 60 04-06	Screw 1/4-20 x 3/8

**NOTE:** All component dimensions given in U.S. inches  
1 inch = 25.4 mm

TRACTOR - - MODEL NO. M165-107T (96041029400), PRODUCT NO. 960 41 02-94  
DRIVE **40**

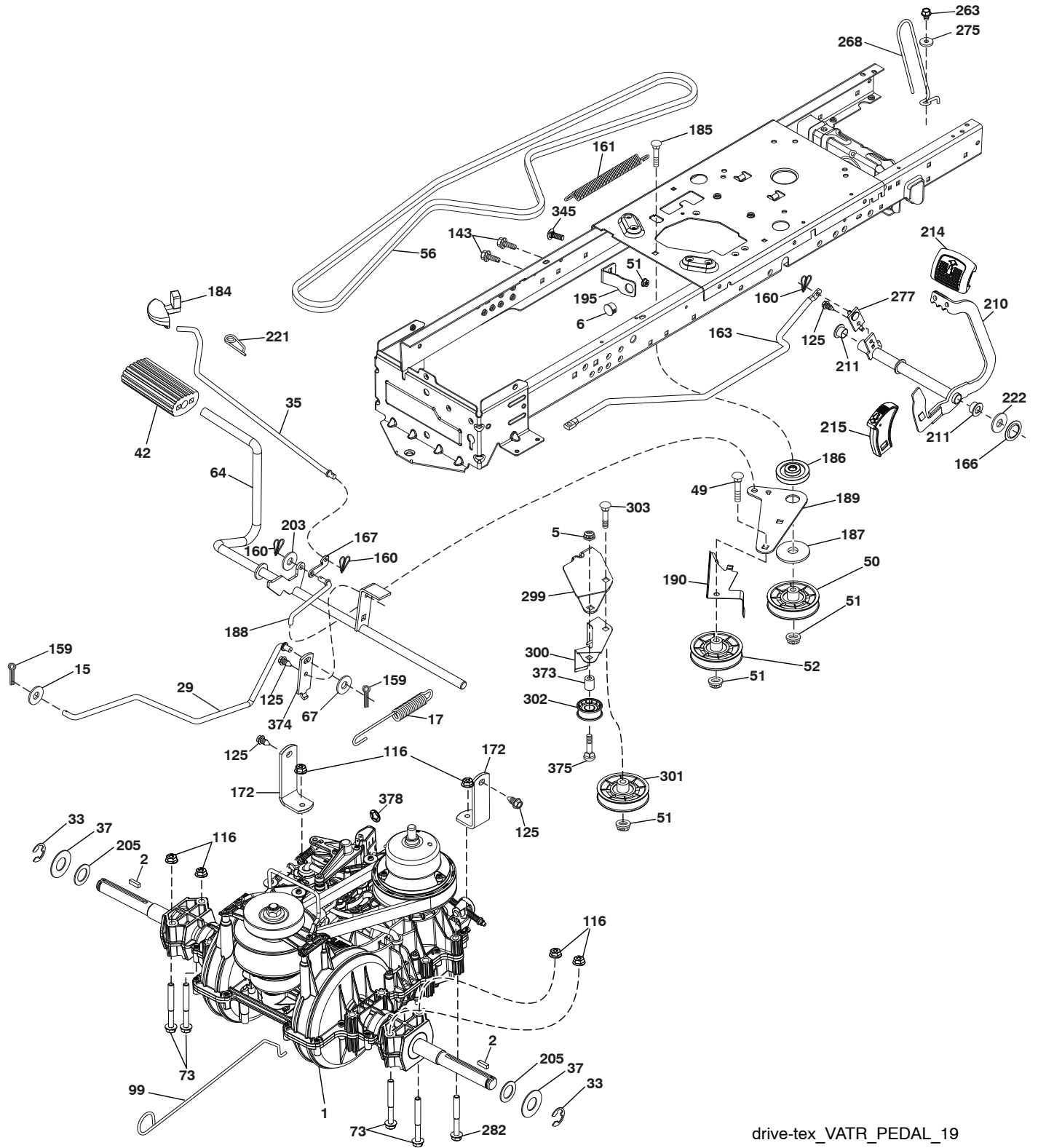

drive-tex\_VATR\_PEDAL\_19



**TRACTOR - - MODEL NO. M165-107T (96041029400), PRODUCT NO. 960 41 02-94  
DRIVE 40**

KEY NO.	PART NO.	DESCRIPTION	KEY NO.	PART NO.	DESCRIPTION
1	-----	Transmission, Gentrans VATR. (580486201) (Order parts from transaxle manufacturer.)	186	532 19 43-21	Spacer.Retainer
2	532 12 35-83	Key.Square .2.0 x .1845/.1865	187	819 13 32-10	Washer.13/32 x 2 x 10 Ga.
5	873 68 06-00	Nut Crownlock	188	532 19 43-23	Link.Clutch.Ground Drive
6	532 12 40-28	Bushing Snap	189	532 19 43-17	Bellcrank.Groundrive.Nstg/Nstl
15	819 13 13-16	Washer 13/32 x 13/16 x 16 Ga.	190	532 19 43-18	Keeper.Bellcrank.Drive.Ground
17	532 41 36-78	Spring Brake	195	581 50 46-01	Brake Bracket
29	581 47 93-01	Rod Brake	203	819 11 11-16	Washer 11/32 x 11/16 x 16
33	812 00 00-01	E-Ring. #5133-75	205	532 12 17-48	Washer.25/32 x 1-5/8 x 16 Ga.
35	532 40 10-31	Rod.Brake.Parking. Lt.Tex	210	532 44 82-70	Weldment Pedal
37	532 18 89-67	Washer Harden .793 x 1.637 x 060	211	532 12 01-83	Bearing Nylon
42	532 12 48-72	Cover.Pedal.Blk.Round	214	532 42 12-63	Pedal Forward Pad
49	872 11 06-14	Bolt.Rdhd.3/8-16Uncx1-3/4.Gr 5	215	532 44 82-54	Cap Pedal Reverse
50	532 19 43-27	Idler.Flat	221	532 40 31-87	Retainer.Spring.Clip.Handle
51	873 90 06-00	Nut, Hex, Flangelock 3/8-16	222	879 21 20-10	Washer 21/32 x 1-1/4 10 Ga.
52	532 19 43-26	Idler.V-Groove.Offset	263	817 00 06-12	Screw Hexwsh Thdr 3/8-16 x 3/4
56	581 60 38-01	Belt Drive	268	532 18 24-02	Guard Muffler
64	532 44 83-53	Shaft Asm. Pedal Brake	275	819 13 16-14	Washer 13/32 x 1 x 14 Ga.
67	819 13 13-12	Washer 13/32 x 13/16 x 12 Ga.	277	532 44 85-00	Subasm. Link Rocker Pedal
73	874 49 05-44	Bolt.Hex.Flghd.5/16-18.Gr.5	282	874 49 05-48	Screw Thdrol 5/16-18 x 3
99	532 43 59-35	Rod Bypass	299	532 41 56-83	Bracket Mount Idler
116	873 90 05-00	Nut, Lock Hex Flange 5/16-18 unc	300	532 41 56-81	Keeper Idler Rear
125	817 00 05-12	Screw.5/16-18 x 3/4.Smgml.Tap/Bl	301	532 41 56-80	Pulley Idler V-Groove
143	817 49 05-08	Screw.Thdrol.5/16-18 x 1/2 Tytt	302	581 42 05-01	Pulley Idler Flat 2.0 Od
159	876 02 04-12	Pin Cotter 1/8 x 3/4	303	872 11 06-18	Bolt Rdhd Sgnk 3/8-16 x 2-1/4
160	532 16 94-84	Retainer.Clip(M).Dia.290	345	872 11 06-06	Bolt Rdhd Sgnk 3/8-16 x 1 Gr. 5
161	532 10 57-09	Spring.Return.Clutch.6.75	373	581 46 18-01	Spacer Idler
163	532 44 82-68	Rod Control Pedal	374	581 47 52-01	Bracket Brake Arm
166	532 42 91-64	Nut Push .625	375	874 76 06-36	Bolt Hex
167	532 40 52-57	Latch.Brake.Parking	378	584 28 77-01	Nut Push 8 mm
172	583 97 42-01	Strap Torque LH/RH			
184	532 44 14-07	Handle.Parking Brake			
185	872 11 06-22	Bolt.Rdhd.3/8-16Unc x 2-3/4 Gr.5			

**NOTE:** All component dimensions given in U.S. inches  
1 inch = 25.4 mm

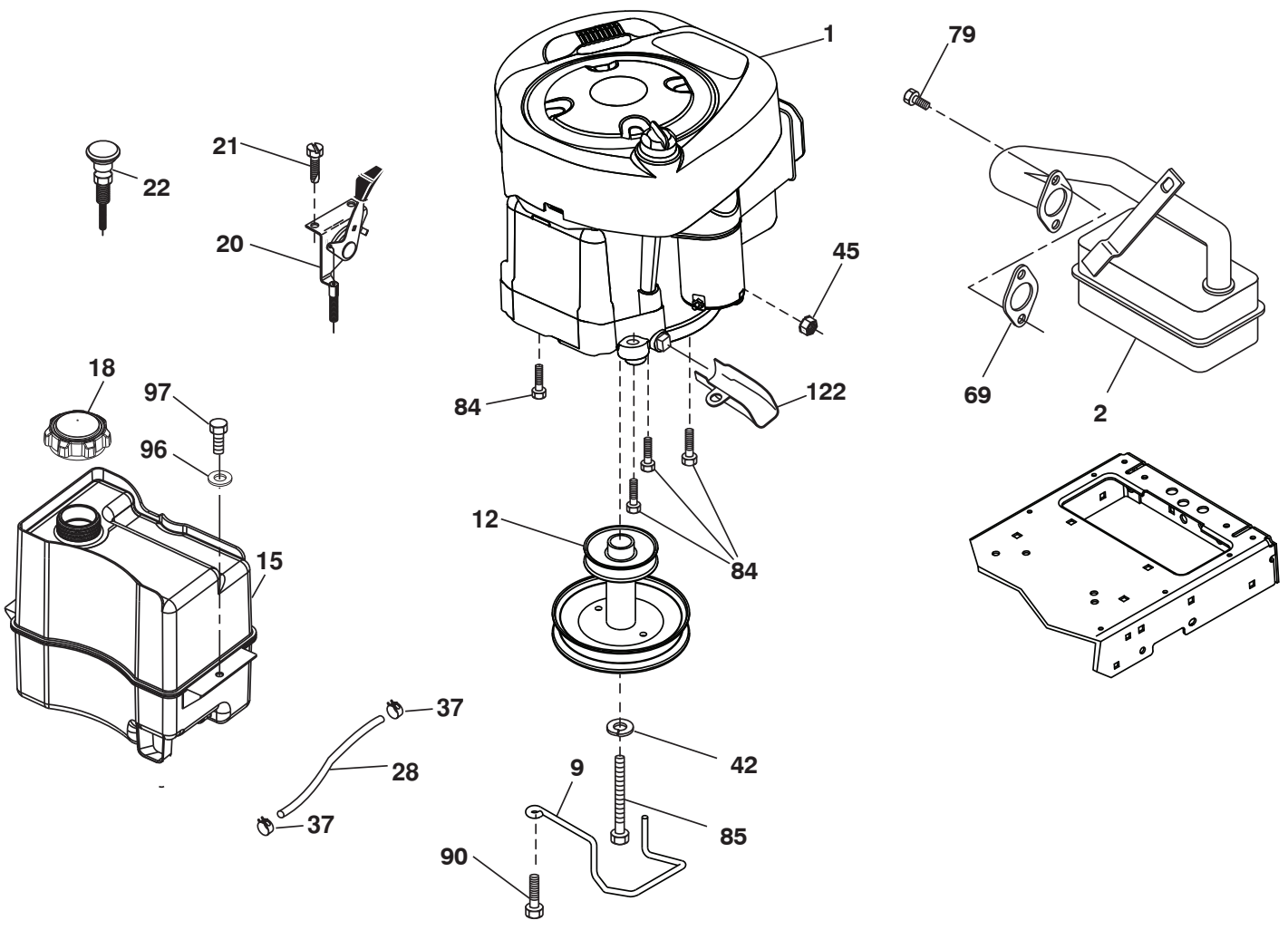

29

**OPTIONAL EQUIPMENT**

**Spark Arrester**

engine-tex\_BS\_78

**TRACTOR - - MODEL NO. M165-107T (96041029400), PRODUCT NO. 960 41 02-94  
ENGINE 24**

KEY NO.	PART NO.	DESCRIPTION
1	- - - - -	Engine B&S Model No. 31A707-2454-B1 (438652)(Order parts from engine manufacturer.)
2	532 13 73-52	Muffler
9	532 19 43-20	Keeper Belt Engine
12	532 40 54-71	Pulley Engine
15	581 28 99-01	Tank Fuel
18	532 43 02-20	Cap Fuel
20	532 18 38-97	Control Throttle
21	532 41 63-58	Screw 10 x 0.750
22	532 19 49-81	Control Choke
28	532 13 70-40	Fuel Line
29	532 13 71-80	Spark Arrester Kit
37	532 12 34-87	Clamp Hose
42	810 04 07-00	Washer Lock 7/16
45	873 51 04-00	Nut Keps Hex 1/4-20 unc
69	532 16 52-91	Gasket
79	532 19 23-34	Screw Socket Hd. 5/16-18 x .75
84	817 06 06-20	Screw 3/8-16 x 1-1/4
85	532 17 39-37	Bolt Hex 7/16-20 x 4 x Gr. 5-1.5
90	817 00 06-16	Screw 3/8-16 x 1.0
96	819 09 14-16	Washer 9/32 x 7/8 x 16
97	817 67 04-12	Screw Hex Wsh. Thdrol. 1/4-20 x 3/4
122	532 42 19-22	Extension Drain Oil

**NOTE:** All component dimensions given in U.S. inches  
1 inch = 25.4 mm

**Engine Power Rating Information**

The gross power rating for individual gas engine models is labeled in accordance with SAE (Society of Automotive Engineers) code J1940 (Small Engine Power & Torque Rating Procedure), and rating performance has been obtained and corrected in accordance with SAE J1995 (Revision 2002-05). Torque values are derived at 3060 RPM; horsepower values are derived at 3600 RPM. Actual gross engine power will be lower and is affected by, among other things, ambient operating conditions and engine-to-engine variability. Given both the wide array of products on which engines are placed and the variety of environmental issues applicable to operating the equipment, the gas engine will not develop the rated gross power when used in a given piece of power equipment (actual "on-site" or net power). This difference is due to a variety of factors including, but not limited to, accessories (air cleaner, exhaust, charging, cooling, carburetor, fuel pump, etc.), application limitations, ambient operating conditions (temperature, humidity, altitude), and engine-to-engine variability. Due to manufacturing and capacity limitations, Briggs & Stratton may substitute an engine of higher rated power for this Series engine.

TRACTOR -- MODEL NO. M165-107T (96041029400), PRODUCT NO. 960 41 02-94  
STEERING ASSEMBLY **41**

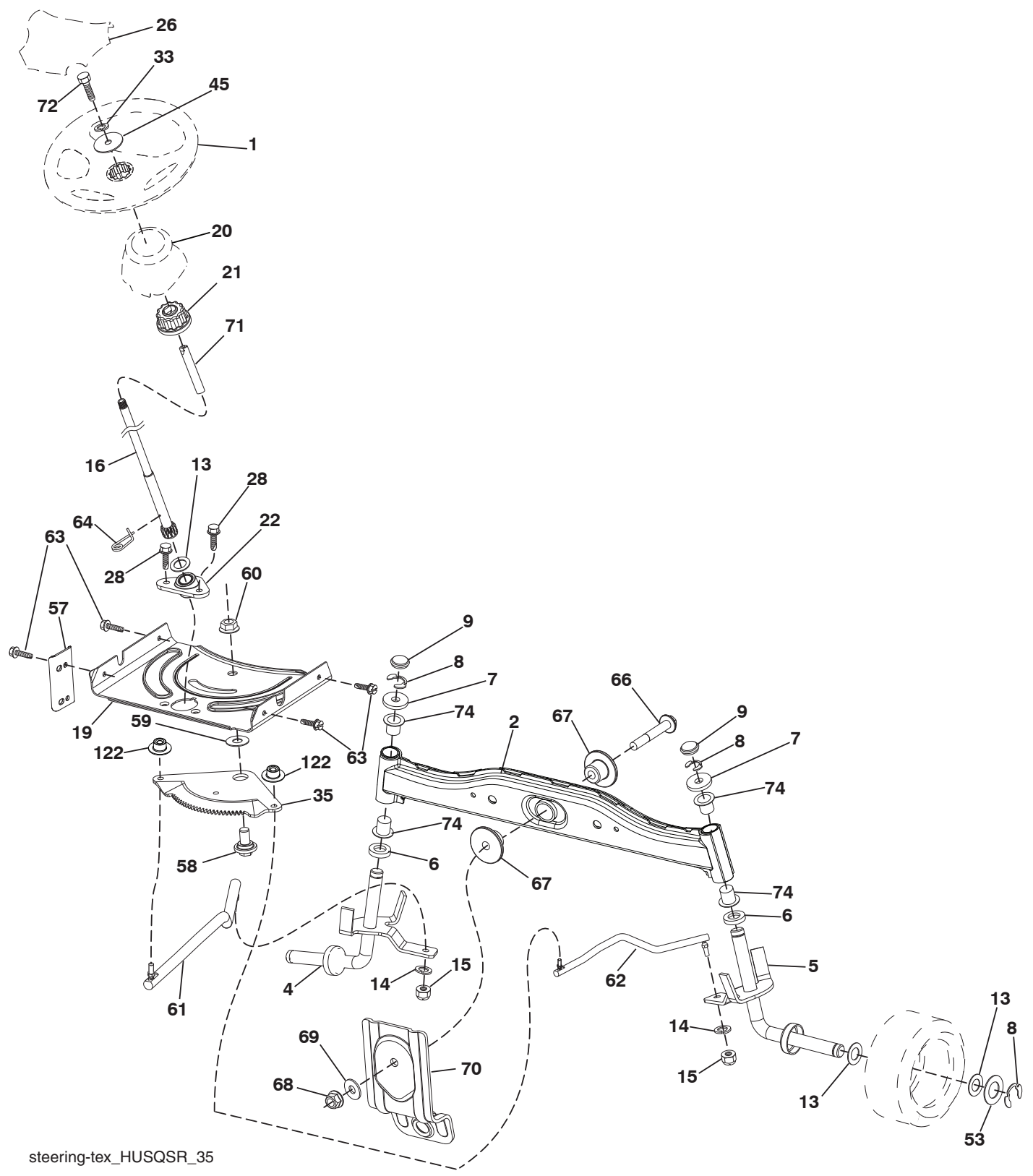

steering-tex\_HUSQSR\_35

**TRACTOR - - MODEL NO. M165-107T (96041029400), PRODUCT NO. 960 41 02-94  
STEERING ASSEMBLY 41**

<b>KEY NO.</b>	<b>PART NO.</b>	<b>DESCRIPTION</b>
1	532 44 28-04	Wheel, Steering
2	532 41 81-68	Axle Asm., Front
4	532 40 30-87	Spindle Asm., LH
5	532 40 30-88	Spindle Asm., RH
6	532 12 49-31	Bearing, Race Thrust Harden
7	532 12 17-48	Washer 25/32 x 1-5/8 x 16 Ga.
8	812 00 00-29	Ring, Clip #T5304-75
9	532 12 12-32	Cap, Spindle
13	532 12 17-49	Washer 25/32 x 1-1/4 x 16 Ga.
14	810 04 06-00	Washer, Lock Hvy. Hlcl. Spr. 3/8
15	873 54 06-00	Nut, Crown Lock 3/8-24 unf
16	532 42 93-73	Shaft Steering
19	532 19 47-29	Plate Steering
20	532 40 97-63	Boot, Steering
21	532 18 67-37	Adapter, Wheel Steering
22	532 42 05-37	Steering Support Lower
26	532 44 77-59	Insert, Wheel Steering
28	817 00 06-12	Screw 3/8-16 x 3/4
33	810 04 05-00	Washer Lock 5/16
35	532 19 47-32	Gear, Sector Plate
45	819 11 38-12	Washer 11/32 x 2-3/8 x 12 Ga.
53	532 18 89-67	Washer Hardened .793 x 1.637 x .060
57	532 40 74-65	Bracket Upstop
58	532 19 47-47	Bolt Shoulder Sector Pivot CFM
59	532 19 47-48	Washer Thrust Sector Steering
60	873 97 10-00	Nut Flange Lock 5/8-11
61	532 19 47-40	Draglink LH
62	532 19 47-41	Draglink, RH
63	817 00 05-12	Screw 5/16-18 x 3/4
64	532 19 98-49	Retainer Clip Spring Steering
66	871 02 07-48	Bolt Hex Fghd. 7/16-14 x 3 Serr.
67	532 19 47-37	Bushing PM Front Axle
68	873 90 07-00	Nut Lock Flange 7/16-14 Gr. 5
69	532 19 91-62	Washer 1.5 x .505 x .118
70	532 19 61-97	Bracket Deck Susp. Front
71	532 19 07-52	Shaft Ext. Steering
72	532 42 89-82	Bolt 5/16-18 x 4 w/Patch
74	532 12 49-37	Bearing
122	532 44 49-62	Cap Gear Sector

**NOTE:** All component dimensions given in U.S. inches  
1 inch = 25.4 mm

TRACTOR -- MODEL NO. M165-107T (96041029400), PRODUCT NO. 960 41 02-94  
MOWER DECK **44**

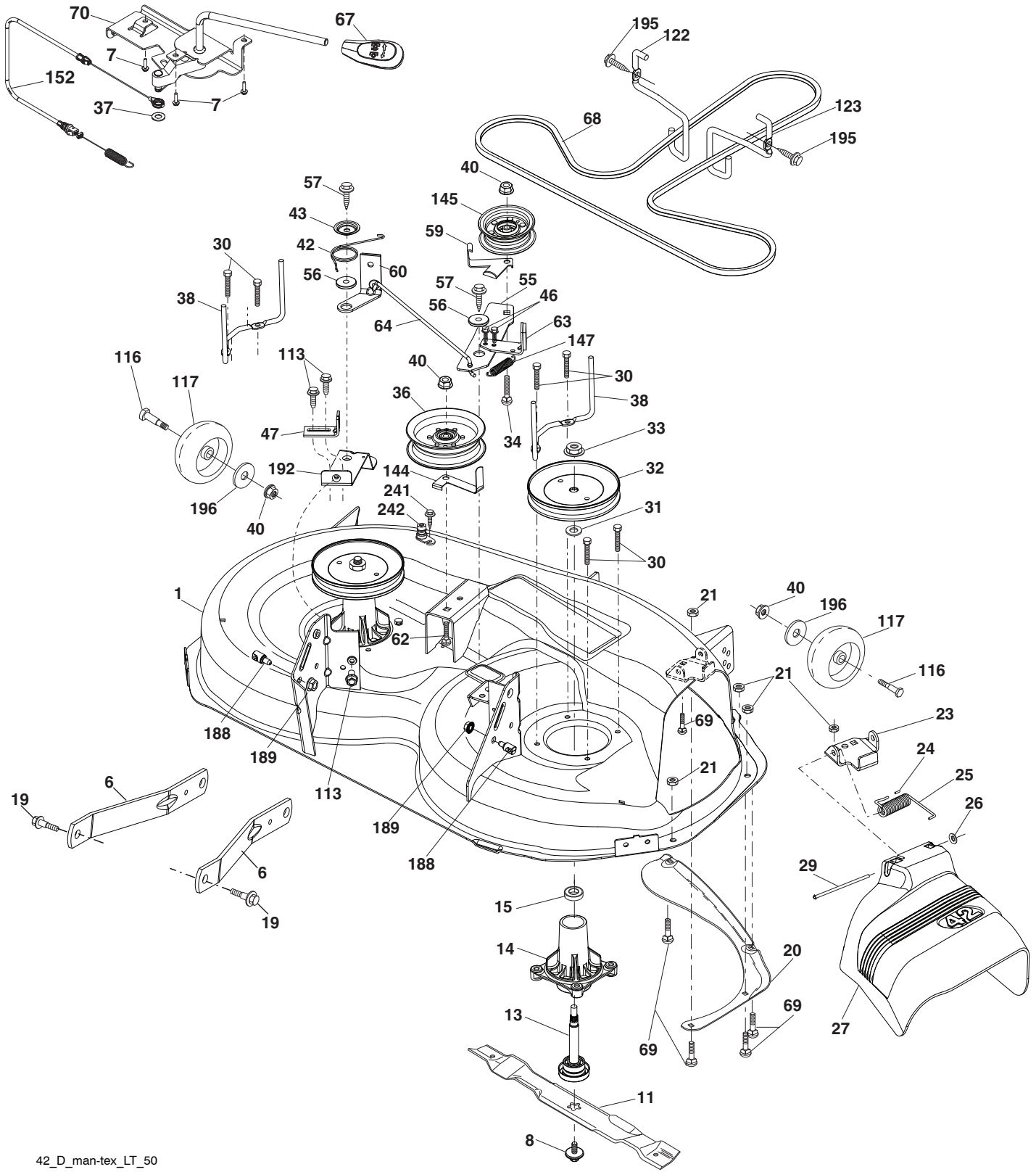

42\_D\_man-tex\_LT\_50

**TRACTOR - - MODEL NO. M165-107T (96041029400), PRODUCT NO. 960 41 02-94  
MOWER DECK 44**

KEY NO.	PART NO.	DESCRIPTION	KEY NO.	PART NO.	DESCRIPTION
1	532 19 64-95	Mower Housing	60	532 19 72-61	Arm Brake Mower
6	532 19 51-86	Arm Suspension	62	872 11 06-16	Bolt Rdhd. Sqnk. 3/8-16 unc x 2
7	532 41 63-58	Screw #10 x 0.750	63	532 19 94-77	Arm Brake Mower
8	532 19 30-03	Bolt/Washer Asm. 7/16-20 unf	64	532 19 97-90	Linkage Brake
11	532 13 89-71	Blade, 42" Hi-Lift (For bagging or discharge)	67	532 40 30-12	Handle, Clutch Cable
13	532 19 28-72	Shaft Assembly, Mandrel	68	532 42 96-36	V-Belt
14	532 18 72-81	Housing, Mandrel	69	872 14 05-05	Bolt Rdhd. Sqnk. 5/16-18 x 5/8
15	532 11 04-85	Bearing, Ball, Mandrel	70	532 40 12-46	Clutch Asm. Manual
19	532 19 65-39	Bolt, Shoulder	113	817 00 05-10	Screw 5/16-18
20	532 15 97-70	Baffle, Vortex	116	532 12 48-42	Bolt, Shoulder
21	873 68 05-00	Nut Crown Lock 5/16-18	117	532 18 86-06	Wheel, Gauge
23	532 19 25-57	Bracket, Deflector	122	532 19 72-58	Keeper Belt Eng. LH
24	532 10 53-04	Cap, Sleeve	123	532 19 72-59	Keeper Belt Eng. RH
25	532 19 70-26	Spring, Torsion, Deflector	144	532 19 92-04	Keeper Belt
26	532 11 04-52	Nut, Push	145	532 19 31-97	Pulley, Idler, Flat
27	532 40 30-04	Shield, Deflector	147	532 40 19-71	Spring Return
29	532 13 14-91	Rod, Hinge	152	532 43 51-11	Cable Clutch Manual w/Spr.
30	532 17 39-84	Screw Thdrol. Rolling Wsh. Hd.	188	532 19 51-61	Stud Fastener
31	532 18 76-90	Washer, Spacer	189	873 90 05-00	Nut Lock Hex Flange
32	532 19 74-73	Pulley, Mandrel	192	532 19 72-60	Bracket Brake Stand LH
33	532 40 02-34	Nut, Toplock, Flanged	195	817 00 06-12	ScrewHexWsh.Thdrol.3/8-16x3/4
34	872 11 06-12	Bolt Carr. Sh. 3/8-16 x 1-1/2 Gr. 5	196	819 12 14-14	Washer 13/32 x 7/8 x 14 Ga.
36	532 19 73-79	Pulley Idler	241	532 15 29-27	Screw
37	819 13 13-16	Washer 13/32 x 13/16 x 16 Ga.	242	532 41 55-98	Port Washout
38	532 43 25-20	Keeper Belt Mandrel	--	532 19 28-70	Mandrel Assembly (Includes Housing (key #14), Shaft Assembly(key #13), and Bearing (key #15)Only - Pulley/Nut/Washer And Blade Bolt/Washers Not Included)
40	873 90 06-00	Nut, Lock Flg. 3/8-16 unc	--	532 43 77-30	Replacement Mower, Complete
42	532 19 84-10	Spring Trosion Brake			
43	532 19 72-56	Spring Torsion Retainer			
46	532 13 77-29	Screw Thdrol. 1/4-20 x 5/8			
47	532 19 72-50	Bracket Clutch Cable			
55	532 43 71-10	Arm, Idler			
56	532 19 90-92	Spacer, Retainer			
57	817 00 06-16	Screw Hex Wsh. Thd. 3/8-16 x 1			
59	532 14 10-43	Guard, Tuv. Idler (94)			

**NOTE:** All component dimensions given in U.S. inches  
1 inch = 25.4 mm

**TRACTOR - - MODEL NO. M165-107T (96041029400), PRODUCT NO. 960 41 02-94**  
**MOWER LIFT 45**

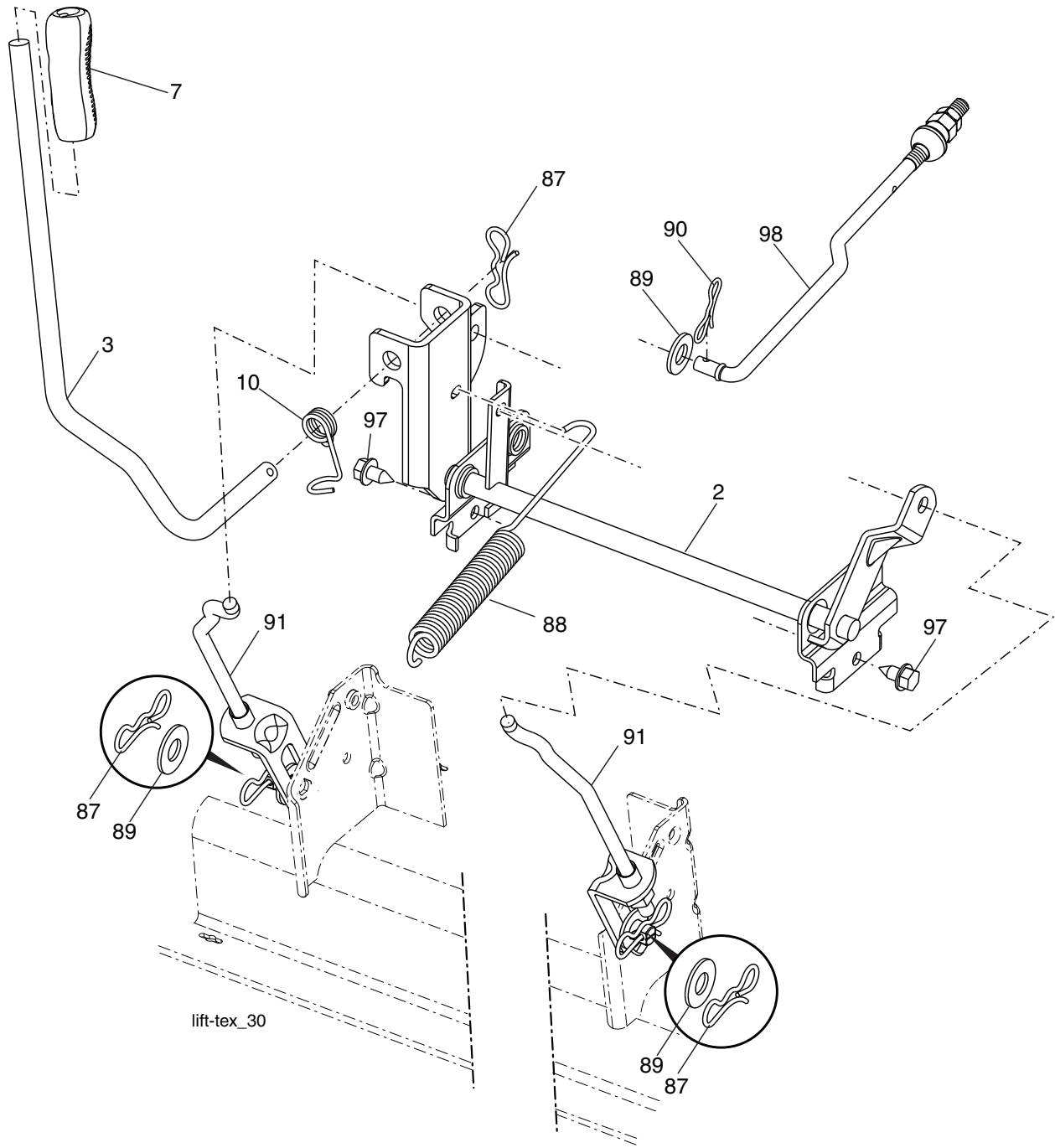

KEY NO.	PART NO.	DESCRIPTION
2	532 42 20-27	Shaft Asm., Cross Lift
3	532 19 52-31	Lever Asm., Lift RH
7	580 96 23-01	Grip, Lever
10	532 19 63-14	Spring Torsion
87	532 19 42-09	Pin Cotter 7/16 Bow Tie Lock
88	532 41 07-10	Spring Lift Assist
89	819 19 19-12	Washer Clear Zinc
90	532 19 42-08	Pin Cotter 5/16 Bow Tie Lock

KEY NO.	PART NO.	DESCRIPTION
91	532 19 79-84	Link Lift Susp. Mower Rear
97	817 00 06-12	Screw 3/8-16 x 3/4
98	532 42 05-25	Link Lift Susp. Front Mower

**NOTE:** All component dimensions given in U.S. inches  
 1 inch = 25.4 mm



**TRACTOR - - MODEL NO. M165-107T (96041029400), PRODUCT NO. 960 41 02-94  
SEAT ASSEMBLY 42**

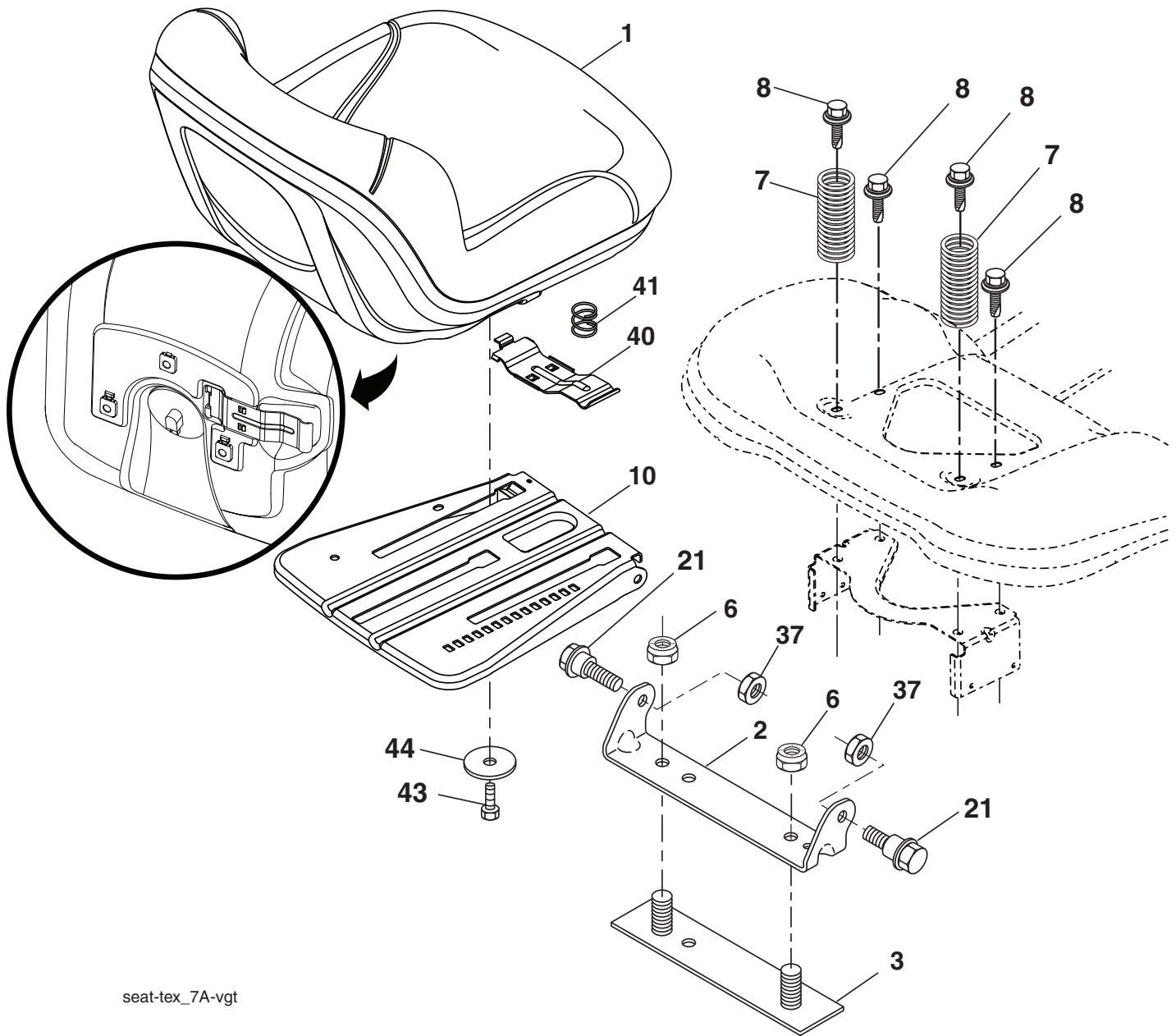

seat-tex\_7A-vgt

KEY NO.	PART NO.	DESCRIPTION
1	581 46 21-01	Seat
2	532 18 01-66	Bracket Pivot Fender
3	532 14 06-75	Strap, Asm. Fender
6	873 80 06-00	Nut, Lock w/Ins. 3/8-16 unc
7	532 12 41-81	Spring, Seat Cprsn.
8	532 17 18-77	Bolt 5/16-18 unc x 3/4 w/Sems.
10	532 19 69-77	Pan, Seat
21	532 17 18-52	Bolt, Shoulder 5/16-18
37	873 80 05-00	Nut, Lock 5/16-18 unc

KEY NO.	PART NO.	DESCRIPTION
40	532 19 76-61	Handle Slide Seat
41	532 19 82-00	Spring Latch Seat
43	874 76 06-12	Bolt 3/8-16 unc x 3/4
44	819 13 38-12	Washer 13/32 x 2-3/8 x 12 Ga.

**NOTE:** All component dimensions given in U.S. inches  
1 inch = 25.4 mm

