

ILLUSTRATED PARTS LIST

MODEL NO. 96041029600

CUSTOMER CATALOG NO. M185-117T

PRODUCT NO. 960 41 02-96

**TRACTOR -- MODEL NO. M185-117T (96041029600), PRODUCT NO. 960 41 02-96
DECALS 27**

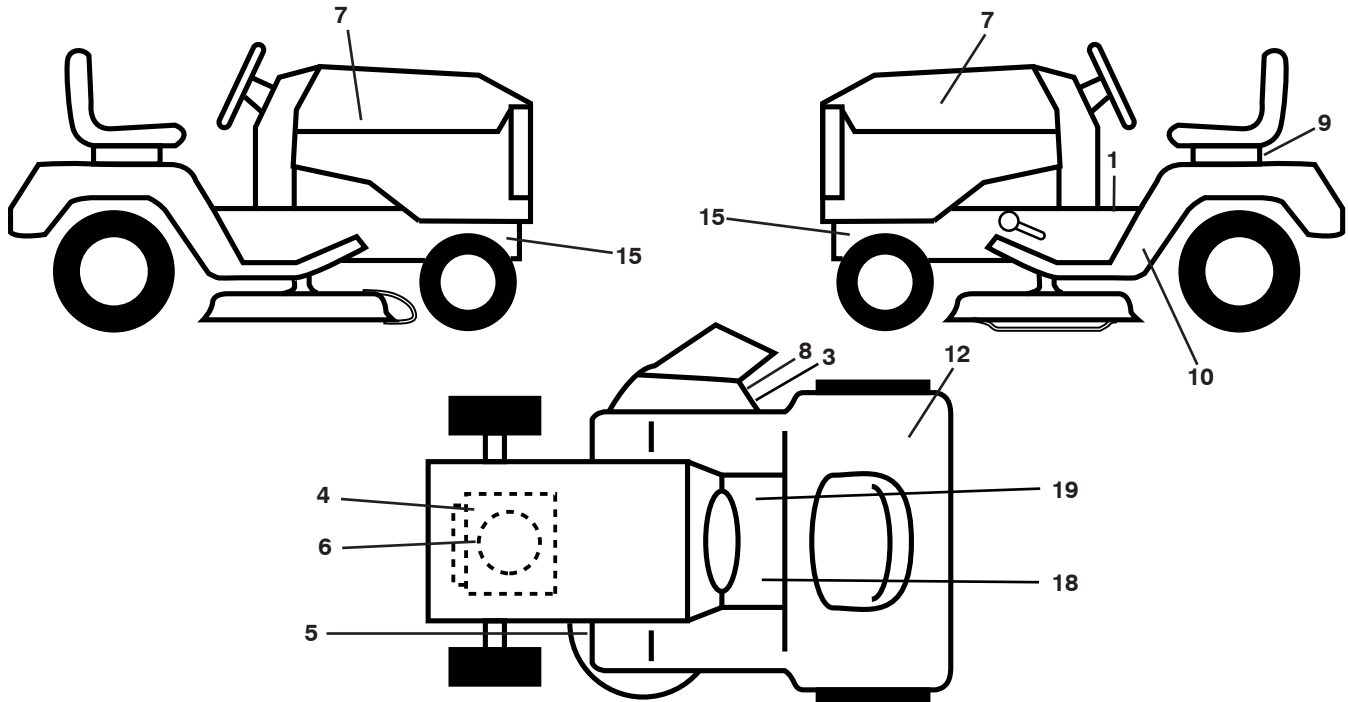

KEY NO.	PART NO.	DESCRIPTION
1	532 40 03-89	Decal, Warning Sym.
3	532 19 63-57	Decal, Warning
4	532 19 68-41	Decal, Warning Engine
5	532 16 03-96	Decal, V-Belt Sch.
6	532 43 74-20	Decal, Eng. HP
7	581 09 12-01	Decal, Hood LH/RH
8	532 18 21-66	Decal, Cutfinger
9	532 14 50-05	Decal, Battery Dnge/Poi
10	581 53 33-20	Decal, Fender Side
12	532 18 04-32	Decal, Fender DB/CE
15	532 15 97-36	Decal, Hot Muffler

KEY NO.	PART NO.	DESCRIPTION
18	532 15 97-37	Decal, Clutch/Brake
19	532 14 08-37	Decal, Saddle Brake Parking
--	532 16 69-60	Decal, Bypass
--	532 16 25-98	Decal, Load Limit
--	532 40 95-05	Pad, Footrest, LH
--	532 40 95-07	Pad, Footrest, RH
--	115 52 64-20	Manual, Oper Euro
--	115 52 65-10	Manual, Oper Scand
--	115 52 66-50	Manual, Oper E-Bloc
--	115 52 67-40	Manual, Oper Baltic

WHEELS AND TIRES

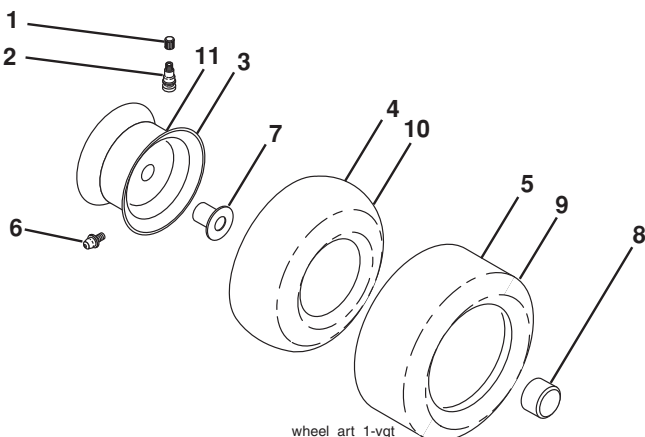

KEY NO.	PART NO.	DESCRIPTION
1	532 05 91-92	Cap, Valve, Tire
2	532 06 51-39	Stem, Valve
3	532 12 51-21	Rim Assembly, Front
4	532 05 99-04	Tube, Front (Service Item Only)
5	532 10 62-22	Tire, Front
6	532 12 49-57	Fitting, Grease (Front Wheel Only)
7	532 12 49-59	Bearing, Flange (Front Wheel Only)
8	532 19 32-68	Cap, Axle
9	532 13 84-68	Tire, Rear
10	532 12 49-26	Tube, Rear (Service Item Only)
11	532 12 51-22	Rim Assembly, Rear
--	532 14 43-34	Sealant, Tire (10 oz. Tube)

NOTE: All component dimensions given in U.S. inches
1 inch = 25.4 mm

TRACTOR - - MODEL NO. M185-117T (96041029600), PRODUCT NO. 960 41 02-96 SCHEMATIC **38**

SCH11

NOTE
YOUR TRACTOR IS EQUIPPED WITH A SPECIAL ALTERNATOR SYSTEM. THE LIGHTS ARE NOT CONNECTED TO THE BATTERY, BUT HAVE THEIR OWN ELECTRICAL SOURCE. BECAUSE OF THIS, THE BRIGHTNESS OF THE LIGHTS WILL CHANGE WITH ENGINE SPEED. AT IDLE THE LIGHTS WILL DIM. AS THE ENGINE IS SPEEDED UP, THE LIGHTS WILL BECOME THEIR BRIGHTEST.

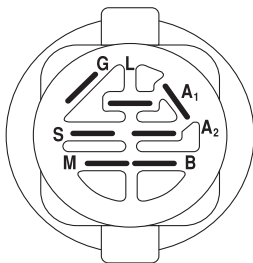

IGNITION SWITCH

POSITION	CIRCUIT	"MAKE"
OFF	M+G+A1	
RUN/OVERRIDE	B+A1	
RUN	B+A1	L+A2
START	B + S + A1	

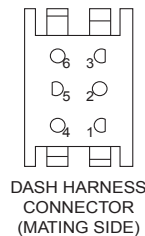
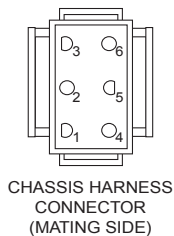
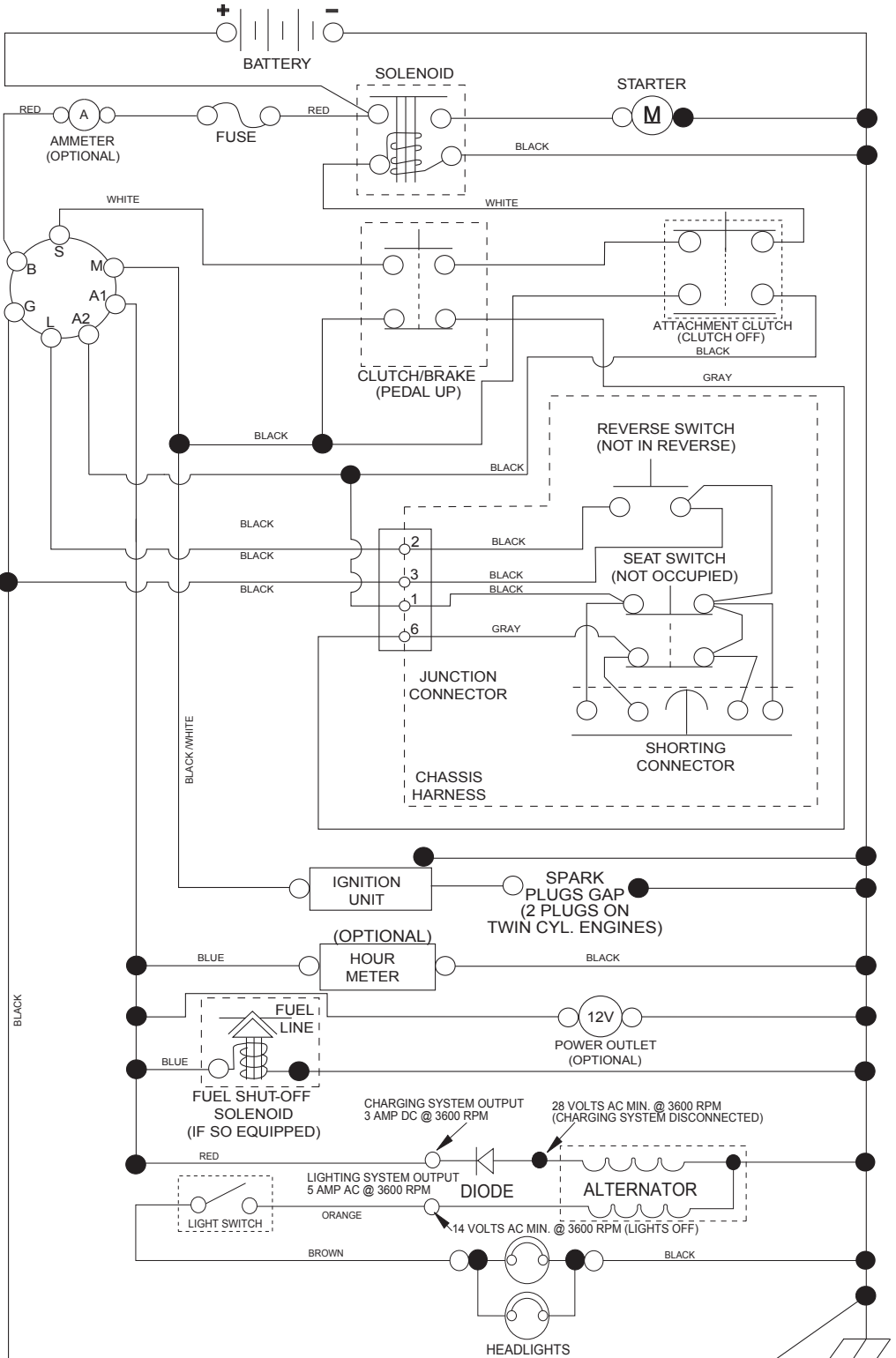

WIRING INSULATED CLIPS
NOTE: IF WIRING INSULATED CLIPS WERE REMOVED FOR SERVICING OF UNIT, THEY SHOULD BE RE-INSTALLED TO PROPERLY SECURE YOUR WIRING.

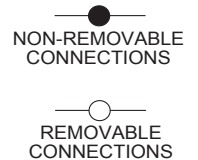

TRACTOR - - MODEL NO. M185-117T (96041029600), PRODUCT NO. 960 41 02-96
ELECTRICAL **32**

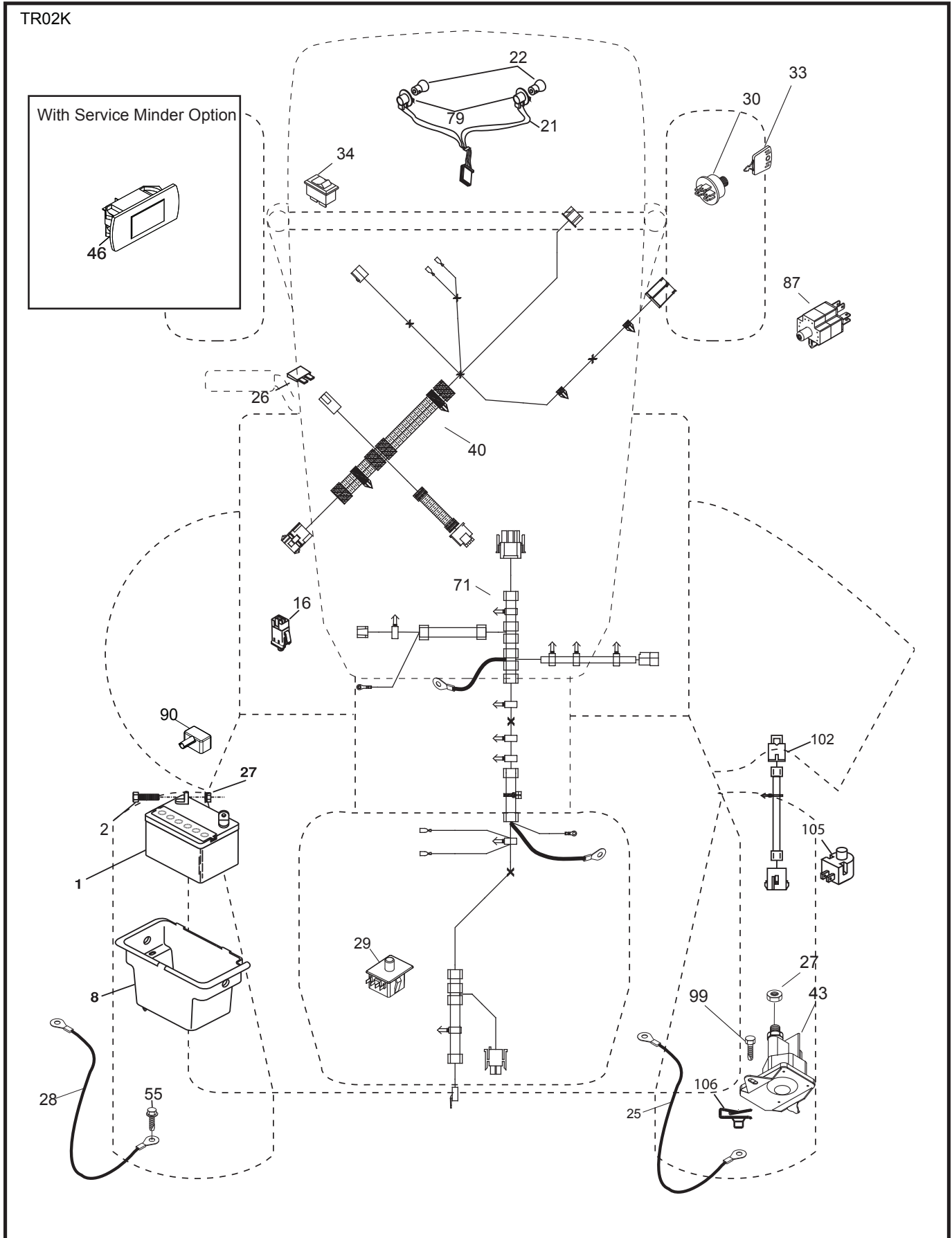

**TRACTOR - - MODEL NO. M185-117T (96041029600), PRODUCT NO. 960 41 02-96
ELECTRICAL 32**

KEY NO.	PART NO.	DESCRIPTION
1	532 16 34-65	Battery
2	874 76 04-12	Bolt Hex Hd 1/4-20 unc x 3/4
8	532 19 32-28	Battery Box
16	532 17 61-38	Switch Interlock
21	532 40 02-52	Harness Socket Light
22	532 00 41-52	Bulb, Light # 1156
25	581 49 80-01	Cable Starter
26	532 17 51-58	Fuse
27	873 51 04-00	Nut Keps Hex 1/4-20 unc
28	532 42 16-86	Cable Ground
29	532 40 15-45	Switch Seat
30	532 19 33-50	Switch Ign
33	532 41 19-35	Key/Chain
34	532 11 07-12	Switch Light/Reset
40	581 02 31-01	Harness Ign. Dash
43	532 19 25-07	Solenoid
55	817 06 05-12	Screw Thdrol 5/16-18 x 3/4
71	581 02 30-01	Harness Ign. Chassis
79	532 17 52-42	Socket Asm. Bulb
87	532 19 78-02	Switch Interlock
90	532 43 53-95	Cover Terminal Battery
99	817 67 04-12	Screw
102	581 02 34-01	Harness Pigtail
105	532 40 75-68	Switch Reverse
106	532 17 48-14	Pal Nut

NOTE: All component dimensions given in U.S. inches
1 inch = 25.4 mm

**TRACTOR - - MODEL NO. M185-117T (96041029600), PRODUCT NO. 960 41 02-96
CHASSIS AND ENCLOSURES **39****

KEY NO.	PART NO.	DESCRIPTION
5	532 44 66-39	Dash
14	532 44 80-42	Hood
15	581 10 31-01	Lens LH
18	581 10 29-01	Grille
25	581 10 30-01	Lens RH
34	580 91 08-01	Plate Engine
36	817 06 05-12	Screw 5/16-18 x 3/4
37	532 42 07-96	Fender
52	873 68 05-00	Nut Crown Lock 5/16
58	532 41 22-80	Drawbar
68	817 49 05-08	Screw THDROL 5/16-18 x 1/2
125	581 68 48-01	Clip Fuel Line
130	532 41 63-58	Screw
138	532 40 97-30	Cupholder
146	581 85 79-01	Bolt
150	584 86 29-03	Air Duct
151	532 44 54-94	Bracket Pivot
152	532 19 95-35	Shield Browning
159	817 00 06-12	Screw 3/8-16 x 3/4
162	532 14 24-32	Screw 1/4 x 1/2
175	532 19 63-04	Crossmember
176	532 40 07-76	Screw 10-24 x 5/8
177	532 19 52-27	Bushing Steering
180	532 41 50-63	Chassis
181	532 40 47-96	Bushing Mtg. Fender Crgo
182	532 40 68-59	Dash Lower
183	874 52 05-20	Bolt 5/16-18 x 1-1/4
189	817 00 05-12	Screw 5/16-18 x 3/4
191	581 22 35-01	Reflector RH
194	873 90 05-00	Nut Lock Hex Flange 5/16-18
195	532 40 41-37	Plug Hole Dash Lower
196	532 41 45-81	Console Asm. Deck Lift
202	581 85 91-01	Side Vent RH
203	581 85 92-01	Side Vent LH
213	874 76 05-12	Bolt 5/16-18 x 3/4
217	532 40 91-67	Rod Pivot Hood
218	532 19 63-95	X-Piece Hood Stop
225	581 10 32-01	Trim Ring
226	578 89 71-01	Emblem
228	532 19 51-61	Stud Fastener
235	532 40 61-29	Spacer Fender
236	873 93 05-00	Nut Lock 5/16-18 unc
237	532 40 37-04	Plug Mount Cargo
287	817 60 04-06	Screw Hex Washhead 1/4-20 x 3/8
289	532 40 35-71	Plug Cruise/Phone
297	581 22 36-01	Reflector LH
306	873 90 06-00	Nut
--	532 44 11-26	Plug Dash SRVMNDR.
--	532 40 09-44	Bumper Kit

NOTE: All component dimensions given in U.S. inches
1 inch = 25.4 mm

TRACTOR -- MODEL NO. M185-117T (96041029600), PRODUCT NO. 960 41 02-96
DRIVE **40**

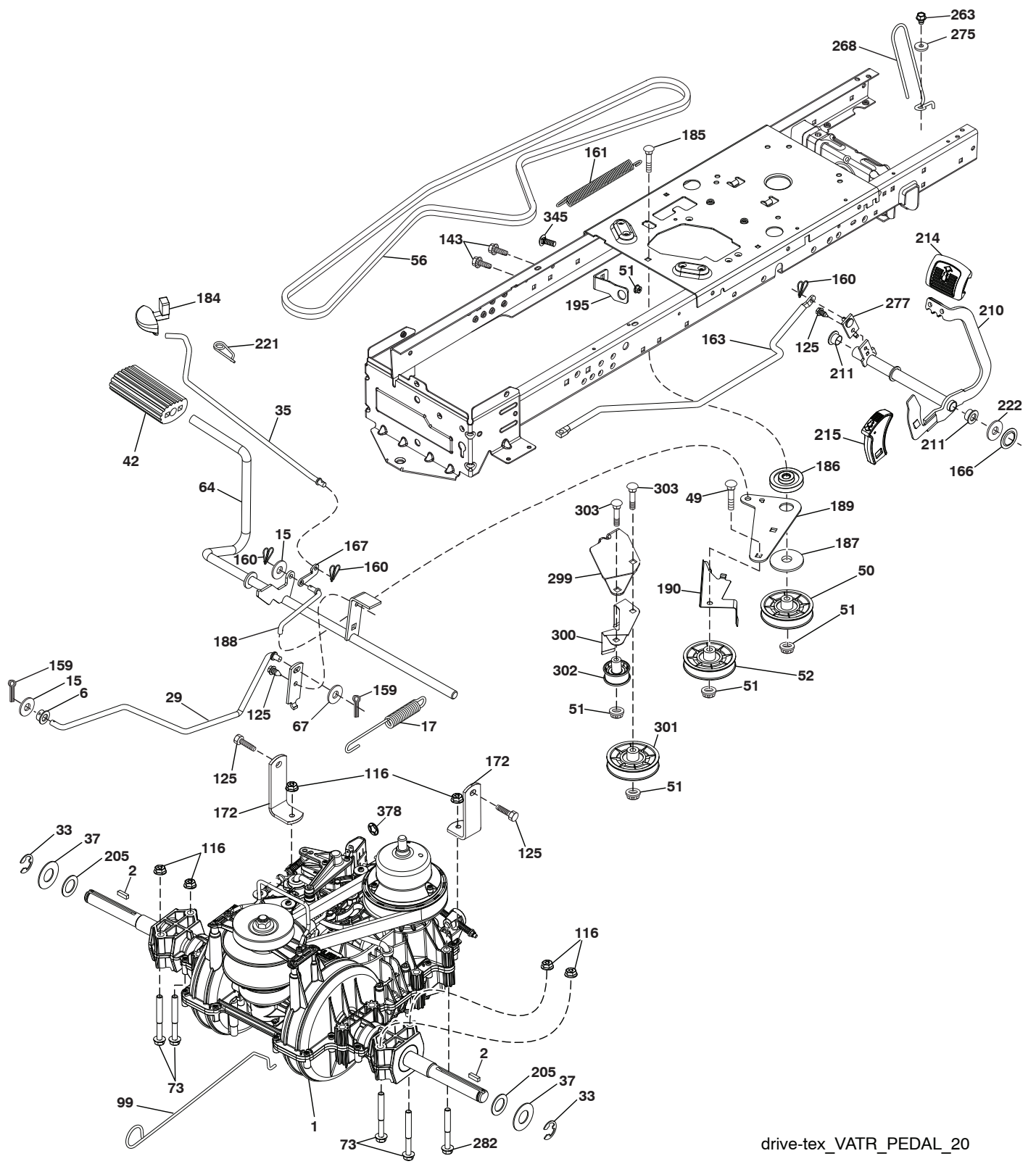

drive-tex_VATR_PEDAL_20

**TRACTOR - - MODEL NO. M185-117T (96041029600), PRODUCT NO. 960 41 02-96
DRIVE 40**

KEY NO.	PART NO.	DESCRIPTION	KEY NO.	PART NO.	DESCRIPTION
1	---	Transaxle, Variator SD Pedal (580486201) (Order parts from transaxle manufacturer.)	172	583 97 42-01	Strap Torque
2	532 12 35-83	Key Square	184	532 44 14-55	Handle Park Brk.
6	532 12 40-28	Bushing Snap	185	872 11 06-22	Bolt 3/8-16 unc x 2-3/4
15	819 13 13-16	Washer 13/32 x 13/16 x 16 Ga.	186	532 19 43-21	Spacer Retainer
17	532 41 36-78	Spring, Brake	187	819 13 32-10	Washer 13/32 x 2 x 10 ga
29	581 47 93-01	Rod, Brake	188	532 19 43-23	Link Clutch Ground Drive
33	812 00 00-01	Ring E	189	532 19 43-17	Bellcrank Ground Drive
35	583 86 45-01	Rod, Brake, Park	190	532 19 43-18	Keeper. Bellcrank
37	532 18 89-67	Washer .793 x 1.637 x 060	195	581 50 46-01	Bracket Brake
42	532 12 48-72	Cover, Foot Pedal	205	532 12 17-48	Washer 25/32 x 1-5/8 16 Ga.
49	872 11 06-14	Bolt 3/8-16 unc	210	532 44 82-70	Rocker Asm. Pedal
50	532 19 43-27	Idler Flat	214	532 42 12-63	Pedal Forward
51	873 68 06-00	Nut Lock	215	532 44 82-54	Pad Pedal Reverse
52	532 19 43-26	Idler V-Groove	211	532 12 01-83	Bearing Nylon
56	581 60 38-01	V-Belt, Drive	221	532 40 31-87	Retainer Spring
64	532 44 83-53	Subasm. Shaft Pedal Brake	222	879 21 20-10	Washer Flat
67	819 13 13-12	Washer 13/32 x 13/16 x 12 Ga.	263	817 00 06-12	Screw
73	874 49 05-44	Bolt Hex 5/16-18 x 3.75	268	532 18 24-02	Guard.Muffler
99	532 43 59-35	Rod Bypass	275	819 13 16-14	Washer 13/32 x 1 x 14
103	873 35 05-00	Nut 5/16-18 unc	277	532 44 85-00	Subasm. Link Rocker Pedal
116	873 90 05-00	Nut Lock Hex Flange 5/16-18	282	874 49 05-48	Screw Thdrol 5/16-18 x 3
125	817 00 05-12	Screw 5/16-18 x 3/4	299	532 41 53-83	Bracket Mount
143	817 49 05-08	Screw Thdrol 5/16-18 x 1/2 TYTT	300	532 41 56-81	Keeper Idler
159	876 02 04-12	Pin Cotter 1/8 x 3/4	301	532 41 56-80	Pulley Idler Groove
160	532 16 94-84	Retainer Clip	302	532 41 56-66	Puller Idler Flat
161	532 10 57-09	Spring, Return, Clutch	303	874 76 06-36	Bolt
163	532 44 82-68	Rod Control	345	872 11 06-06	Bolt 3/8-16 unc
166	532 42 91-64	Nut Push .625	378	584 28 77-01	Nut Push 8 mm
167	532 40 52-57	Latch Brake Parking			

NOTE: All component dimensions given in U.S. inches
1 inch = 25.4 mm

TRACTOR - - MODEL NO. M185-117T (96041029600), PRODUCT NO. 960 41 02-96
ENGINE **24**

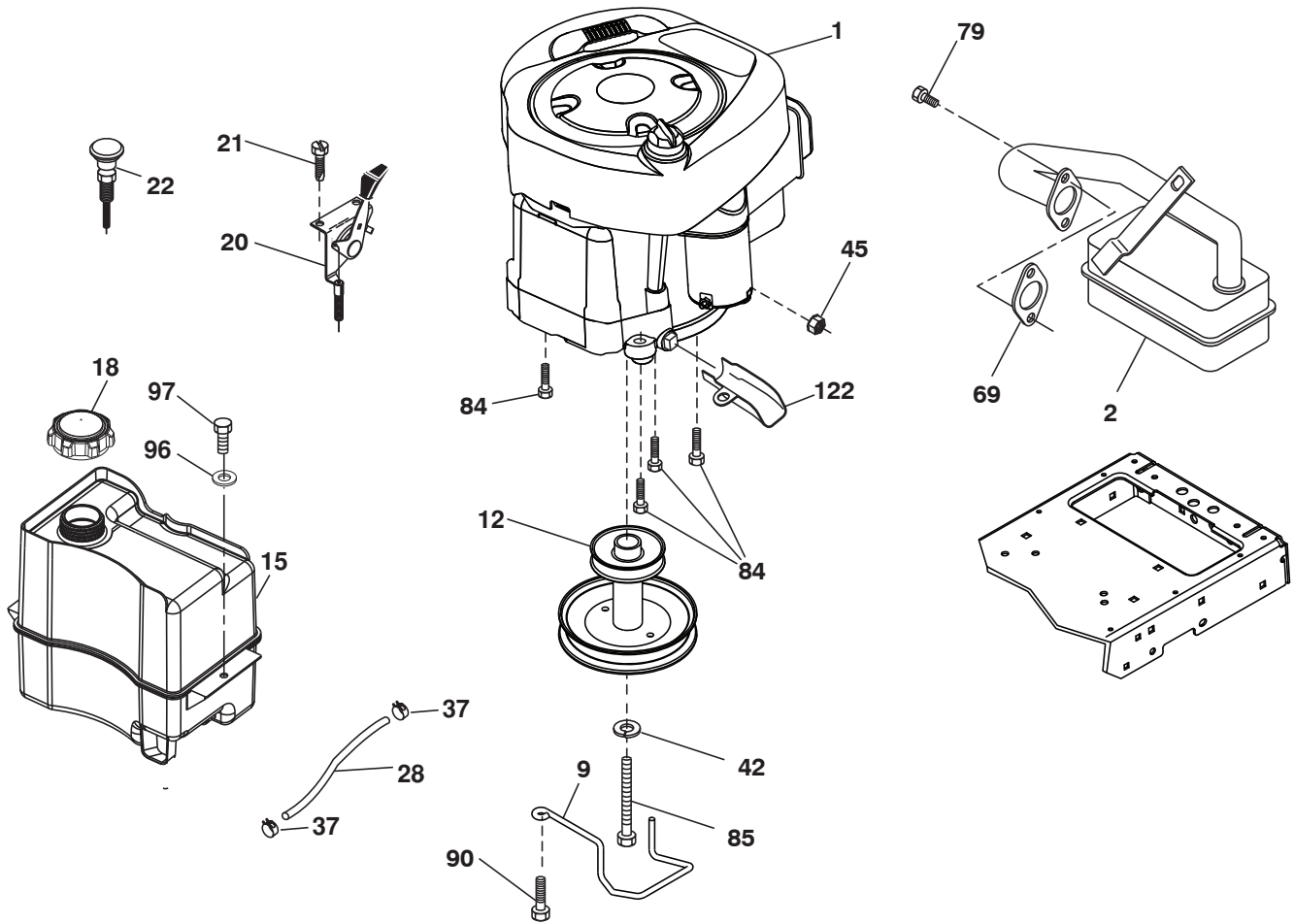

29

OPTIONAL EQUIPMENT
Spark Arrester

engine-tex_BS_78

**TRACTOR - - MODEL NO. M185-117T (96041029600), PRODUCT NO. 960 41 02-96
ENGINE 24**

KEY NO.	PART NO.	DESCRIPTION
1	- - - - -	Engine Briggs Model No. 31N707-2441 (438156) (Order parts from engine manufacturer.)
2	532 13 73-52	Muffler
9	532 19 43-20	Keeper Belt Engine
12	532 40 54-72	Pulley Engine
15	532 40 75-51	Tank Fuel
18	532 43 02-20	Cap Asm
20	532 40 15-08	Control Throttle
21	532 41 63-58	Screw #10 x 0.750 BOS Thread
22	532 19 49-81	Control Choke
28	532 13 70-40	Fuel Line
29	532 13 71-80	Spark Arrester Kit
37	532 12 34-87	Clamp Hose
42	810 04 07-00	Washer Lock 7/16
45	873 51 04-00	Nut Keps Hex 1/4-20 unc
69	532 16 52-91	Gasket
79	532 19 23-34	Screw 5/16-18 x .75
84	817 06 06-20	Screw 3/8-16 x 1-1/4
85	532 17 39-37	Bolt 7/16-20 x 4
90	817 00 06-16	Screw 3/8-16 x 1
96	819 09 14-16	Washer 9/32 x 7/8 x 16 Ga.
97	817 67 04-12	Screw 1/4 - 20 x 3/4
122	532 42 19-22	Extension Drain Oil

NOTE: All component dimensions given in U.S. inches
1 inch = 25.4 mm

Engine Power Rating Information

The gross power rating for individual gas engine models is labeled in accordance with SAE (Society of Automotive Engineers) code J1940 (Small Engine Power & Torque Rating Procedure), and rating performance has been obtained and corrected in accordance with SAE J1995 (Revision 2002-05). Torque values are derived at 3060 RPM; horsepower values are derived at 3600 RPM. Actual gross engine power will be lower and is affected by, among other things, ambient operating conditions and engine-to-engine variability. Given both the wide array of products on which engines are placed and the variety of environmental issues applicable to operating the equipment, the gas engine will not develop the rated gross power when used in a given piece of power equipment (actual "on-site" or net power). This difference is due to a variety of factors including, but not limited to, accessories (air cleaner, exhaust, charging, cooling, carburetor, fuel pump, etc.), application limitations, ambient operating conditions (temperature, humidity, altitude), and engine-to-engine variability. Due to manufacturing and capacity limitations, Briggs & Stratton may substitute an engine of higher rated power for this Series engine.

TRACTOR -- MODEL NO. M185-117T (96041029600), PRODUCT NO. 960 41 02-96
STEERING ASSEMBLY [41]

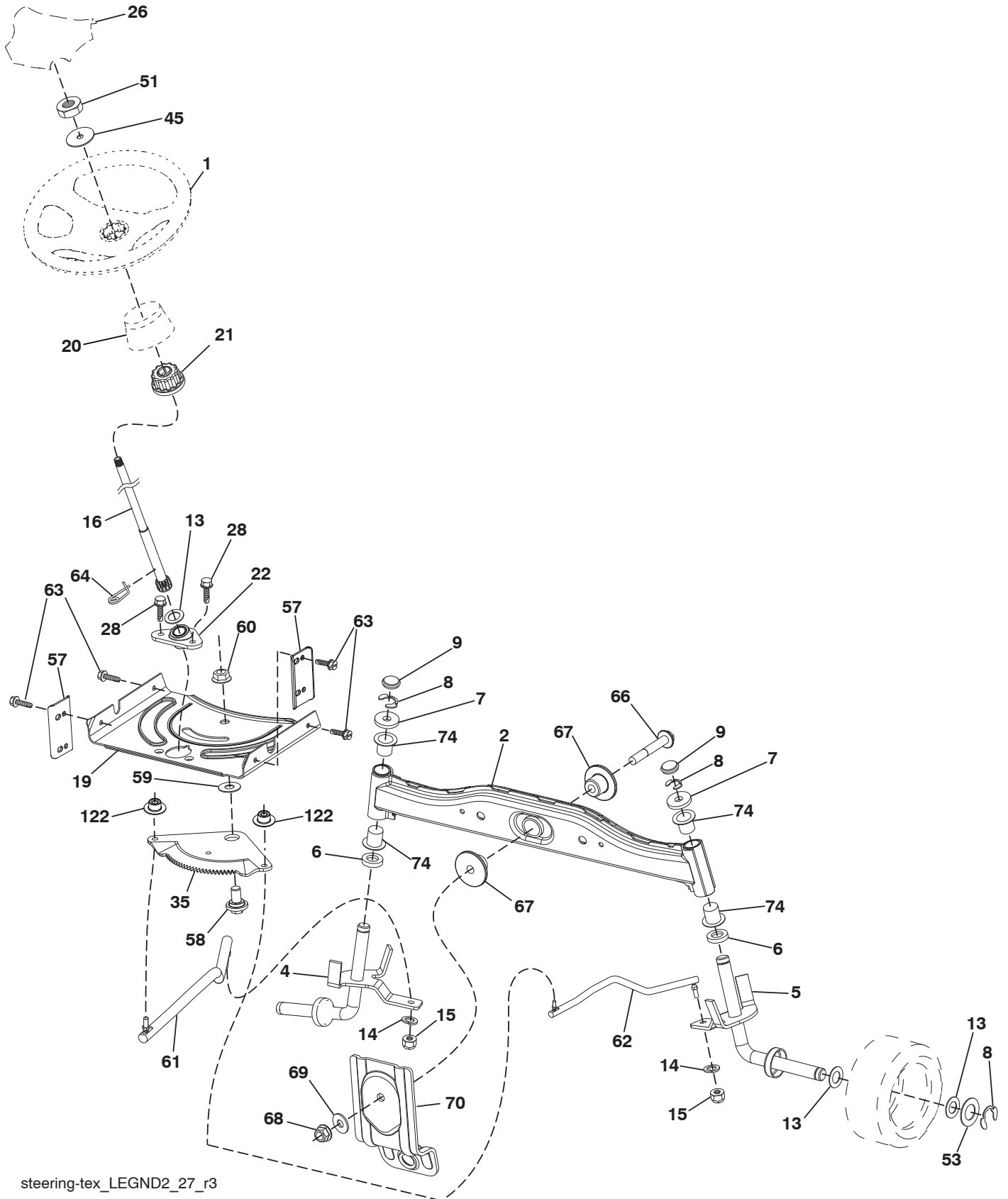

steering-tex_LEGND2_27_r3

**TRACTOR - - MODEL NO. M185-117T (96041029600), PRODUCT NO. 960 41 02-96
STEERING ASSEMBLY 41**

KEY NO.	PART NO.	DESCRIPTION
1	581 57 05-01	Wheel, Steering
2	532 41 81-68	Axle Asm., Front
4	532 40 30-87	Spindle Asm., LH
5	532 40 30-88	Spindle Asm., RH
6	532 12 49-31	Bearing, Race Thrust Harden
7	532 12 17-48	Washer 25/32 x 1-5/8 x 16 Ga.
8	812 00 00-29	Ring, Clip #T5304-75
9	532 12 12-32	Cap, Spindle
13	532 12 17-49	Washer 25/32 x 1-1/4 x 16 Ga.
14	810 04 06-00	Washer, Lock Hvy Hlcl Spr 3/8
15	873 54 06-00	Nut, Crown Lock 3/8-24 unf
16	532 19 47-46	Shaft Steering
19	532 19 47-29	Plate Steering
20	532 42 47-40	Boot Steering
21	532 18 67-37	Adapter, Wheel Steering
22	532 42 05-37	Steering Support Lower
26	581 78 01-01	Insert, Wheel Steering
28	817 00 06-12	Screw 3/8-16 x 3/4
35	532 19 47-32	Gear, Sector Plate
45	819 18 38-12	Washer 9/16 x 2-3/8 12 Ga.
51	873 94 08-00	Nut Hex Jam Toplock 1/2-20 unf
53	532 18 89-67	Washer Hardened .793 x 1.637 x .060
57	532 40 74-65	Bracket Upstop
58	532 19 47-47	Bolt Shoulder Sector Pivot CFM
59	532 19 47-48	Washer Thrust Sector Steering
60	873 97 10-00	Nut Flange Lock 5/8-11
61	532 19 47-40	Draglink LH
62	532 19 47-41	Draglink, RH
63	817 00 05-12	Screw 5/16-18 x 3/4
64	532 19 98-49	Retainer Clip Spring Steering
66	871 02 07-48	Bolt Hex Fghd 7/16-14 x 3 Serr
67	532 19 47-37	Bushing PM Front Axle
68	873 90 07-00	Nut Lock Flange 7/16-14 Gr. 5
69	532 19 91-62	Washer 1.5 x .505 x .118
70	532 19 61-97	Bracket Deck Susp. Front
74	532 12 49-37	Bearing
122	532 44 49-62	Cap Gear Sector

NOTE: All component dimensions given in U.S. inches
1 inch = 25.4 mm

TRACTOR -- MODEL NO. M185-117T (96041029600), PRODUCT NO. 960 41 02-96
MOWER DECK **44**

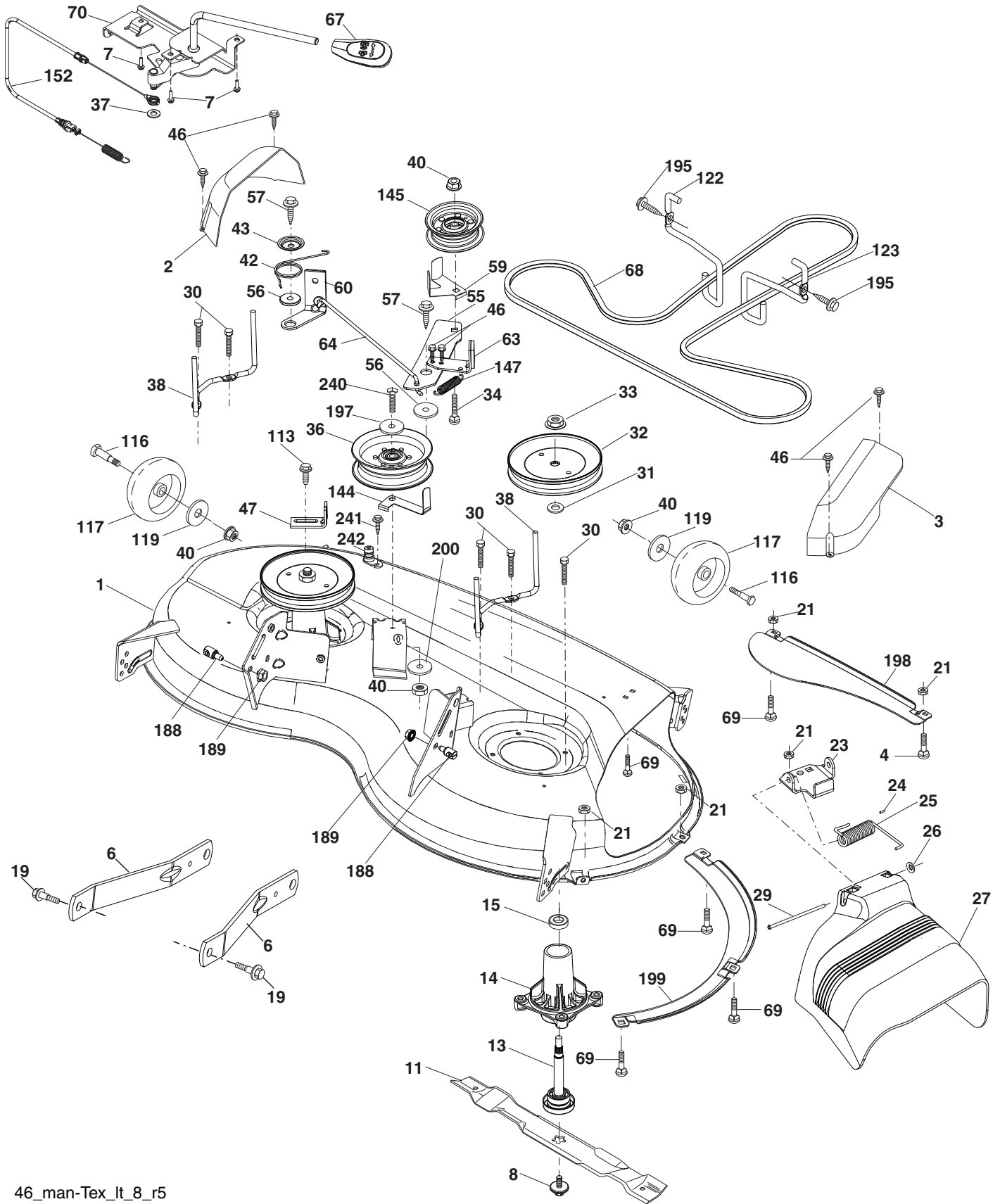

46_man-Tex_lt_8_r5

**TRACTOR - - MODEL NO. M185-117T (96041029600), PRODUCT NO. 960 41 02-96
MOWER DECK 44**

KEY NO.	PART NO.	DESCRIPTION	KEY NO.	PART NO.	DESCRIPTION
1	532 44 16-16	Mower Housing	60	532 19 94-71	Arm Brake Mower
2	532 40 55-07	Cover Mandrel LH	63	532 19 94-77	Arm Brake Mower
3	532 40 55-06	Cover Mandrel RH	64	532 40 51-38	Linkage Brake
4	874 76 05-12	Bolt Hex HD 5/16-18	67	532 40 30-12	Handle Clutch Cable
6	532 19 51-86	Arm Suspension	68	532 40 51-43	Belt, Drive
7	532 41 63-58	Screw #10	69	872 14 05-05	Bolt
8	532 19 30-03	Bolt/Washer Asm 7/16-20 unf	70	532 19 99-72	Clutch Asm
11	532 40 53-80	Blade	113	817 00 05-10	Bolt 5/16-18
13	532 19 28-72	Shaft Assembly, Mandrel	116	532 19 34-06	Bolt, Shoulder
14	532 18 72-81	Housing, Mandrel	117	532 17 48-73	Wheel, Gauge
15	532 11 04-85	Bearing, Ball, Mandrel	119	819 13 20-12	Washer 13/32 x 1-1/4 x 12 Ga.
19	532 19 65-39	Bolt, Shoulder	122	532 19 72-58	Keeper Belt LH
21	873 68 05-00	Nut, Crownlock 5/16-18 unc	123	532 19 72-59	Keeper Belt RH
23	532 19 25-57	Bracket, Deflector	144	532 19 92-04	Keeper Belt
24	532 10 53-04	Cap, Sleeve	145	532 19 31-97	Pulley, Idler, Primary
25	532 19 70-26	Spring, Torsion, Deflector	147	532 40 18-72	Spring Return
26	532 11 04-52	Nut, Push	152	584 24 35-01	Cable Clutch
27	532 40 53-57	Shield, Deflector	188	532 19 51-61	Stud Fastener
29	532 13 14-91	Rod, Hinge	189	873 90 05-00	Nut Lock Hex Flange
30	532 17 39-84	Screw Thdrol Rolling Wsh Hd	195	817 00 06-12	Screw
31	532 18 76-90	Washer, Spacer	197	819 13 13-12	Washer 13/32 x 13/16 x 12 Ga.
32	532 19 74-73	Pulley, Mandrel	198	532 40 31-49	Baffle Center Front
33	532 40 02-34	Nut, Toplock, Flanged	199	532 40 31-50	Baffle Front RH
34	872 11 06-12	Bolt Carr Sh. 3/8-16 x 1-1/2 Gr. 5	200	532 41 35-24	Washer 13/32 x 1 x 1/2 x 11 Ga.
36	532 19 73-79	Pulley Idler	240	874 52 06-36	Bolt Fin Hex 3/8-16 x 2-1/4 Gr. 5
37	819 13 13-16	Washer 13/32 x 13/16 x 16	241	532 15 29-27	Screw #10-32.5 3/8 Flange
38	532 43 25-20	Keeper Belt Mandrel	242	532 41 55-98	Port Washout
40	873 90 06-00	Nut, Lock Flg. 3/8-16 unc	--	532 19 28-70	Mandrel Assembly (Includes housing, shaft and shaft hardware only-pulley not included)
42	532 19 72-56	Spring Torsion Retainer	--	532 41 80-63	Replacement Mower, Complete
43	532 19 84-10	Spring Torsion Brake			
46	532 13 77-29	Screw 1/4-20 x 5/8			
47	532 19 72-50	Bracket Clutch Cable			
55	532 19 72-49	Arm, Idler			
56	532 19 90-92	Spacer, Retainer			
57	817 00 06-16	Screw 3/8-16 x 1			
59	532 14 10-43	Guard, Tuv Idler			

NOTE: All component dimensions given in U.S. inches
1 inch = 25.4 mm

TRACTOR - - MODEL NO. M185-117T (96041029600), PRODUCT NO. 960 41 02-96
MOWER LIFT 45

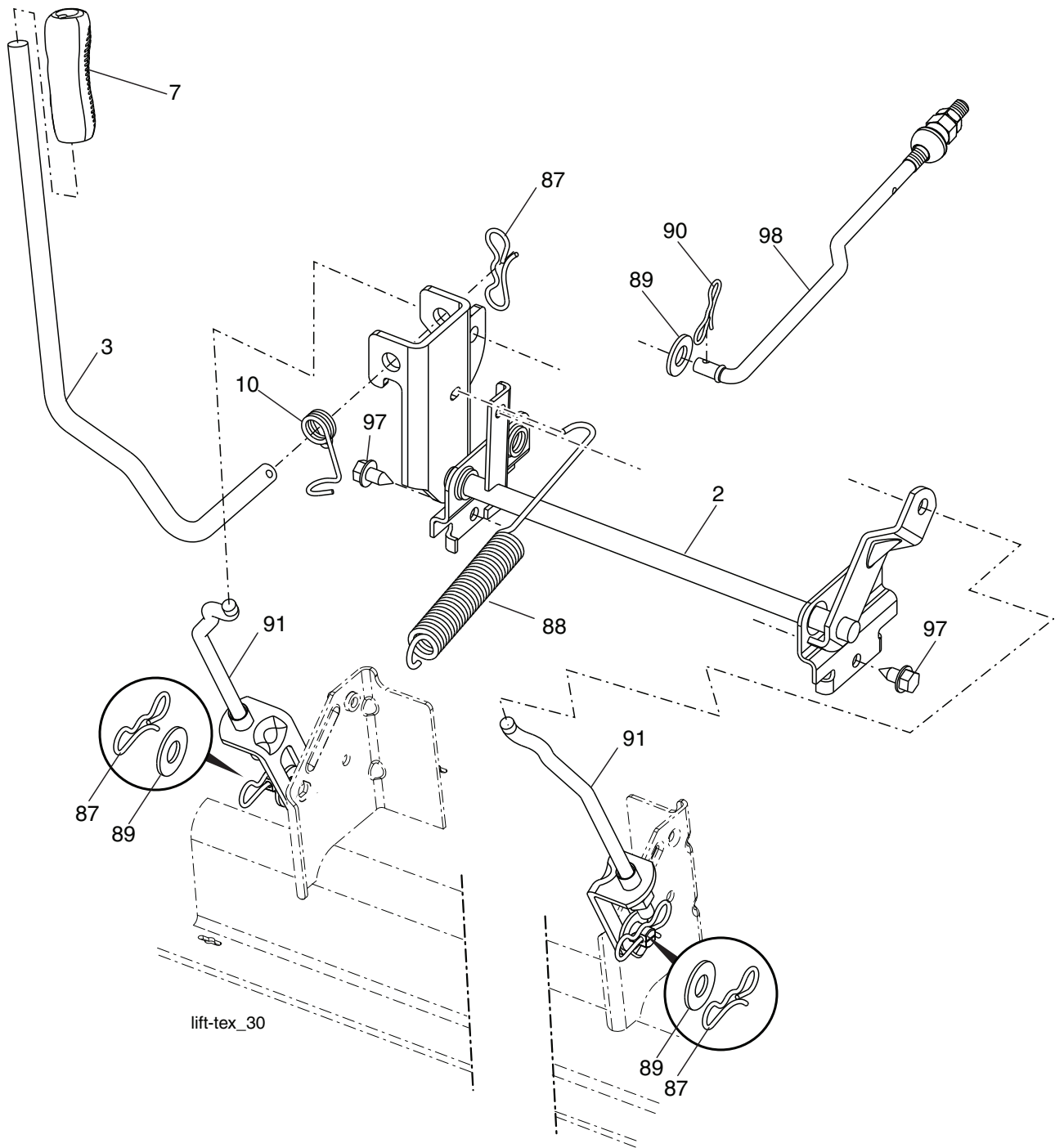

KEY NO.	PART NO.	DESCRIPTION
2	532 42 20-27	Shaft Asm., Lift
3	532 19 52-31	Lever Asm., Lift RH
7	580 96 23-01	Grip, Lever
10	532 19 63-14	Spring Torsion
87	532 19 42-09	Pin Cotter 7/16 Bow Tie Lock
88	532 41 07-10	Spring Lift Assist
89	819 19 19-12	Washer 17/32 x 1-3/16 x 12 Ga.
90	532 19 42-08	Pin Cotter 5/16 Bow Tie Lock

KEY NO.	PART NO.	DESCRIPTION
91	532 19 79-84	Link Lift Susp Mower Rear
97	817 00 06-12	Screw 3/8-16 x .75
98	532 42 05-25	Link Lift Susp. Front Mower

NOTE: All component dimensions given in U.S. inches
 1 inch = 25.4 mm

**TRACTOR - - MODEL NO. M185-117T (96041029600), PRODUCT NO. 960 41 02-96
SEAT ASSEMBLY 42**

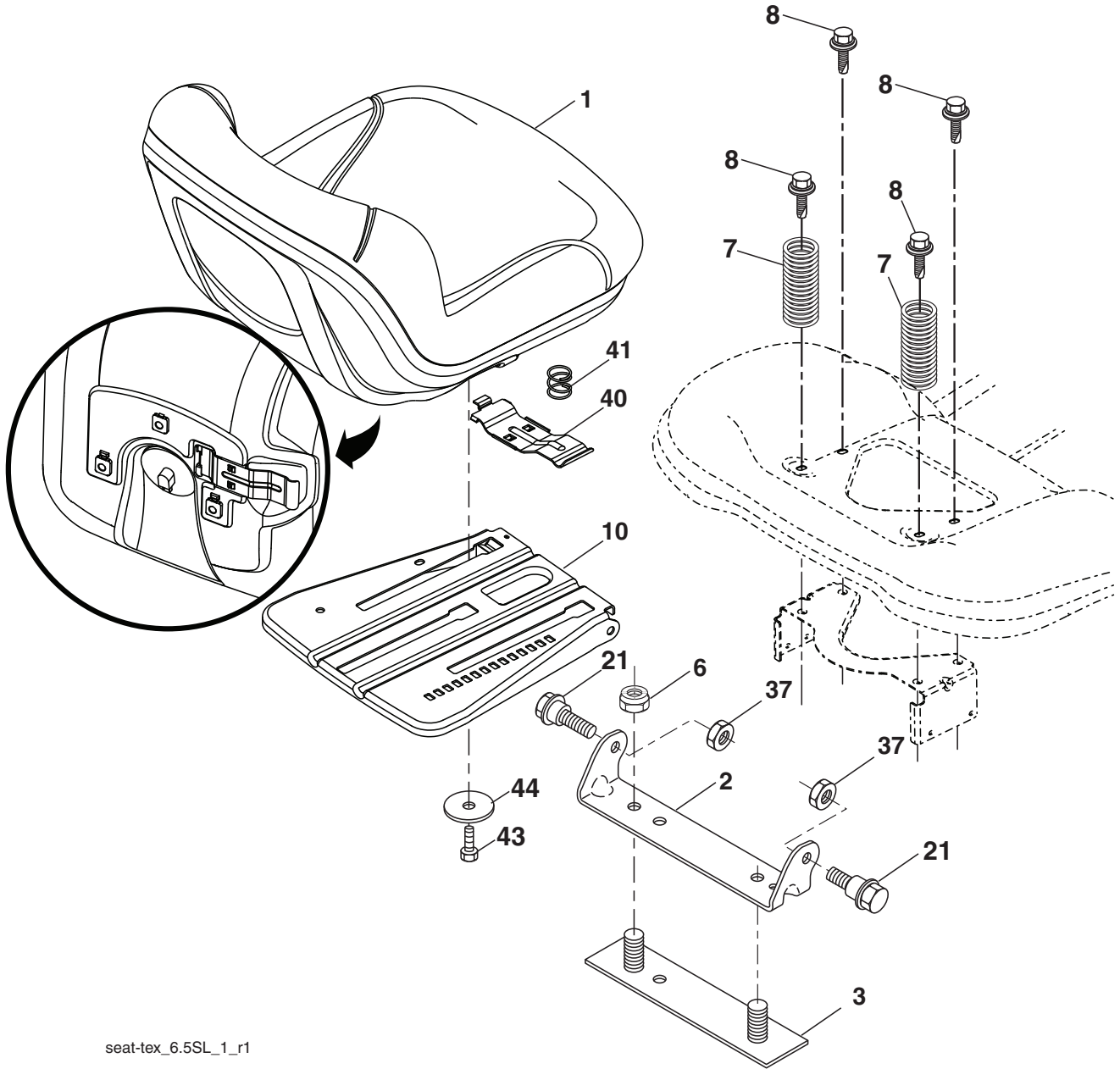

seat-tex_6.5SL_1_r1

KEY NO.	PART NO.	DESCRIPTION
1	581 46 22-01	Seat
2	532 18 01-66	Bracket Pivot Fender
3	532 14 06-75	Strap, Asm Fender
6	873 80 06-00	Nut, Lock w/Ins. 3/8-16 unc
7	532 12 41-81	Spring, Seat Cprsn
8	532 17 18-77	Bolt 5/16-18 unc x 3/4 w/Sems
10	532 19 69-77	Pan, Seat
21	532 17 18-52	Bolt, Shoulder 5/16-18

KEY NO.	PART NO.	DESCRIPTION
37	873 80 05-00	Nut, Lock 5/16-18 unc
40	532 19 76-61	Handle Slide Seat
41	532 19 82-00	Spring Latch Seat
43	874 76 06-12	Bolt 3/8-16 x 3/4
44	819 13 38-12	Washer 13/32 x 2-3/8 x 12 Ga.

NOTE: All component dimensions given in U.S. inches
1 inch = 25.4 mm

