

# **ILLUSTRATED PARTS LIST**

**MODEL NO. 96041022202**

**CUSTOMER CATALOG NO. M200-117H**

**PRODUCT NO. 960 41 02-22**

**TRACTOR -- MODEL NO. M200-117H (96041022202), PRODUCT NO. 960 41 02-22  
DECALS 27**

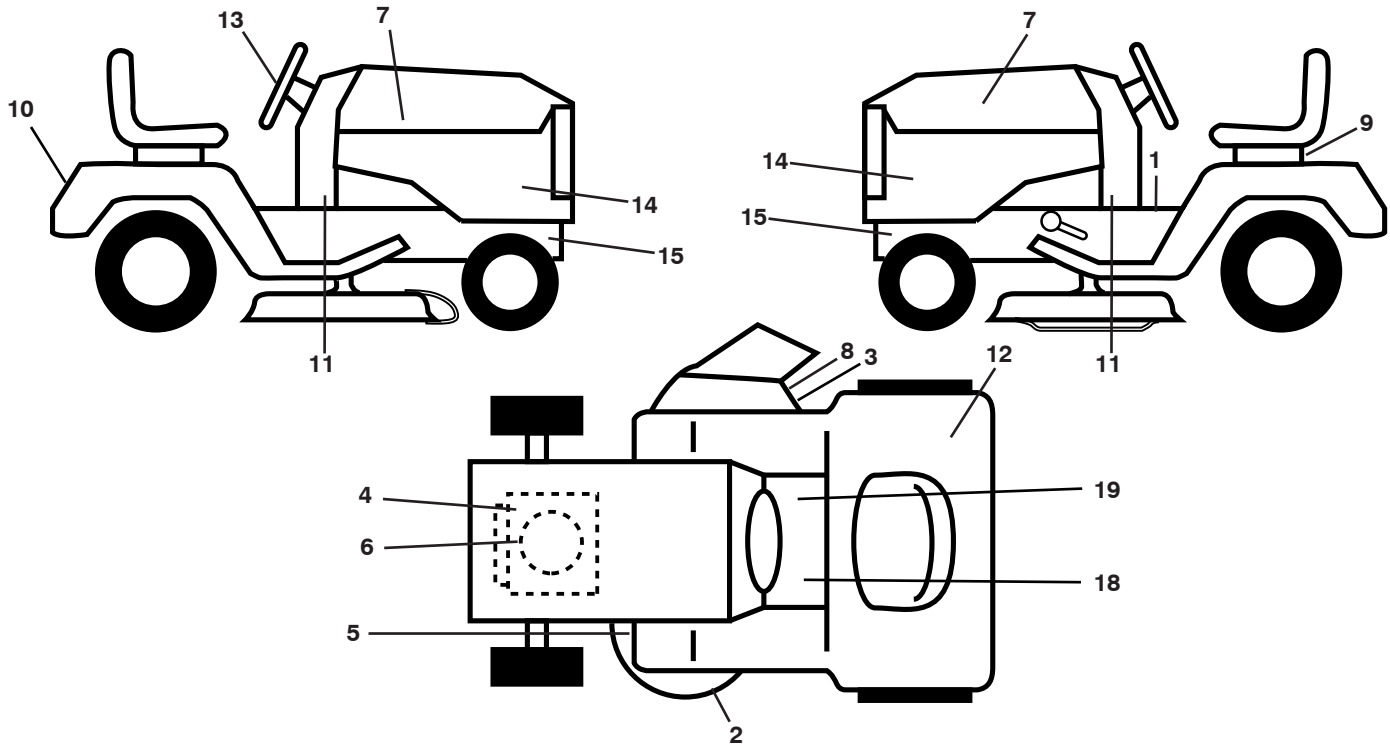

KEY NO.	PART NO.	DESCRIPTION
1	532 40 03-89	Decal, Warning Sym.
2	532 13 49-99	Decal, Mower Enviro
3	532 19 63-57	Decal, Warning
4	532 19 68-41	Decal, Warning Engine
5	532 16 03-96	Decal, V-Belt Sch.
6	532 43 74-23	Decal, Eng. HP
7	532 44 72-09	Decal, Hood LH/RH
8	532 18 21-66	Decal, Cutfinger
9	532 14 50-05	Decal, Battery Dnge/Poi
10	532 44 44-52	Decal, Fender
11	532 43 85-32	Decal, Turbo
12	532 18 04-32	Decal, Fender DB/CE
13	532 43 79-96	Decal, Steering Whl

KEY NO.	PART NO.	DESCRIPTION
14	532 44 64-14	Decal, Panel Side
15	532 15 97-36	Decal, Hot Muffler
18	532 15 97-37	Decal, Clutch/Brake
19	532 14 08-37	Decal, Saddle Brake Parking
--	532 16 69-60	Decal, Bypass
--	532 16 25-98	Decal, Load Limit
--	532 40 95-05	Pad, Footrest, LH
--	532 41 12-73	Pad, Footrest, RH
--	532 44 83-18	Manual, Operator's Euro
--	532 44 83-19	Manual, Operator's Scan
--	532 44 83-20	Manual, Operator's EBloc
--	532 44 83-21	Manual, Operator's Baltic

**WHEELS AND TIRES**

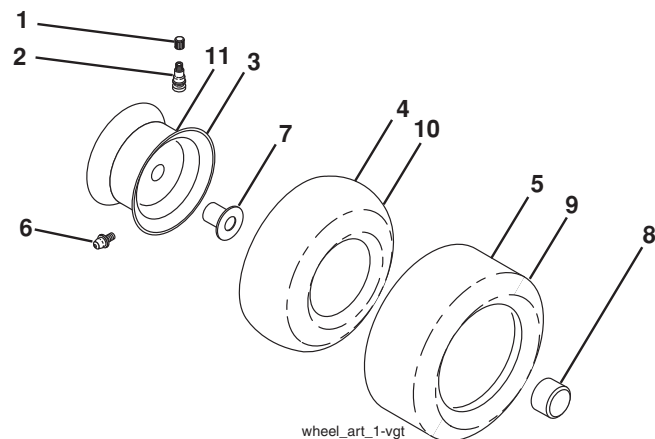

KEY NO.	PART NO.	DESCRIPTION
1	532 05 91-92	Cap, Valve, Tire
2	532 06 51-39	Stem, Valve
3	532 12 51-21	Rim Assembly, Front
4	532 05 99-04	Tube, Front (Service Item Only)
5	532 10 62-22	Tire, Front
6	532 12 49-57	Fitting, Grease (Front Wheel Only)
7	532 12 49-59	Bearing, Flange (Front Wheel Only)
8	532 17 50-39	Cap, Axle
9	532 13 84-68	Tire, Rear
10	532 12 49-26	Tube, Rear (Service Item Only)
11	532 12 51-22	Rim Assembly, Rear
--	532 14 43-34	Sealant, Tire (10 oz. Tube)

**NOTE:** All component dimensions given in U.S. inches  
1 inch = 25.4 mm

# TRACTOR -- MODEL NO. M200-117H (96041022202), PRODUCT NO. 960 41 02-22

## SCHEMATIC 38

SCH13

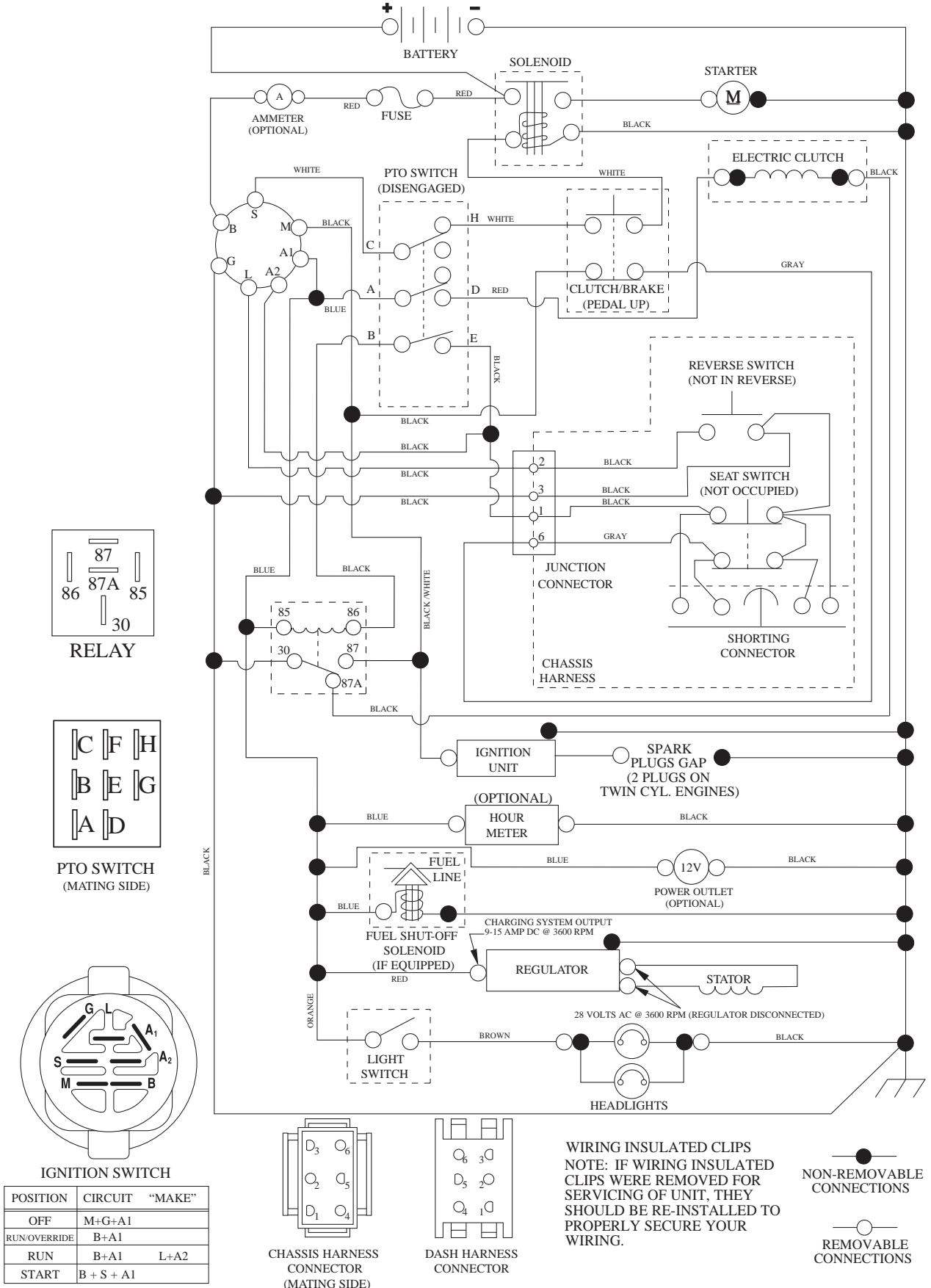

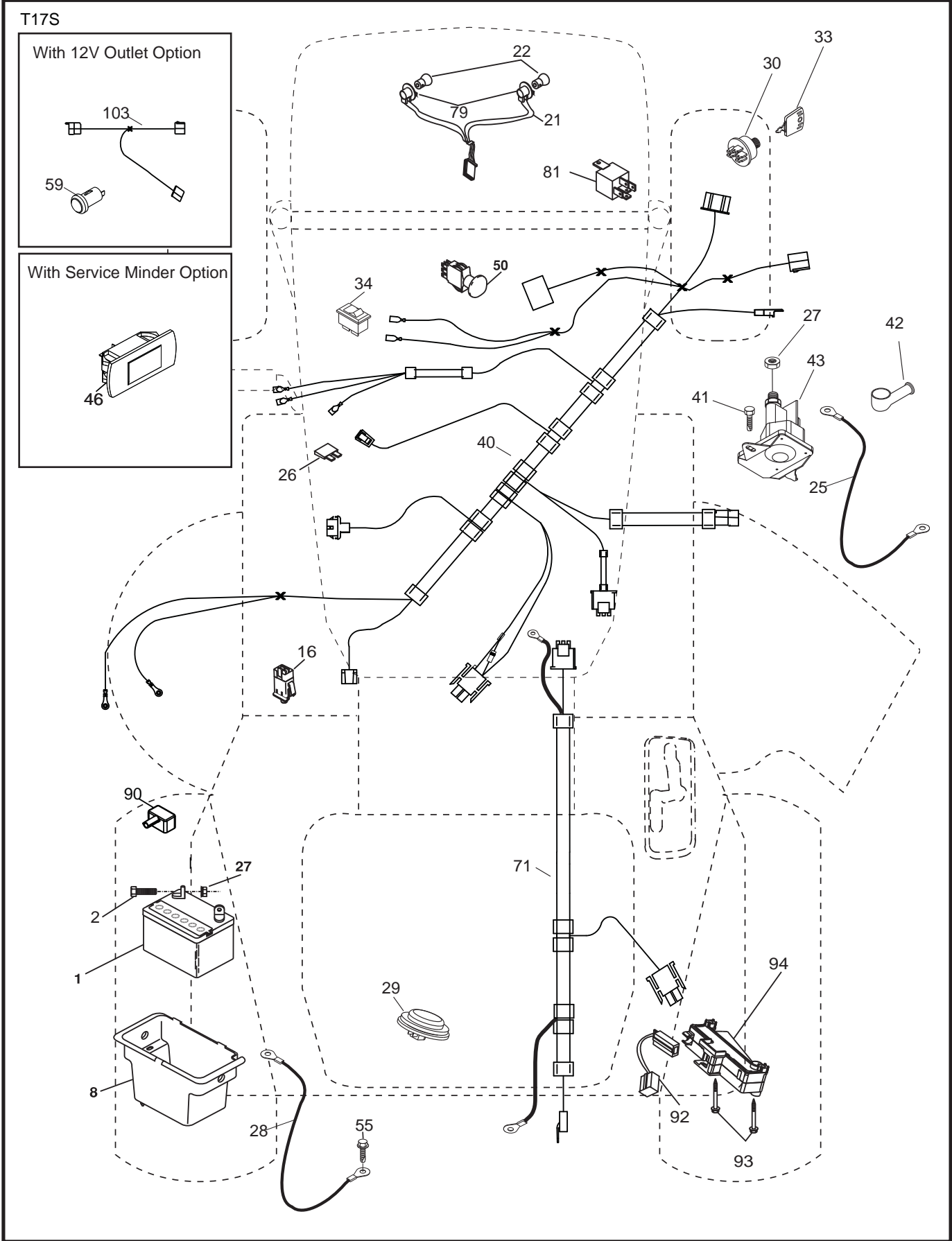

**TRACTOR - - MODEL NO. M200-117H (96041022202), PRODUCT NO. 960 41 02-22  
ELECTRICAL 32**

KEY NO.	PART NO.	DESCRIPTION
1	532 16 34-65	Battery
2	874 76 04-12	Bolt Hex Hd 1/4-20 unc x 3/4
8	532 19 32-28	Battery Box
16	532 17 61-38	Switch Interlock
21	532 40 02-52	Harness Socket Light W/4152J
22	532 00 41-52	Bulb, Light # 1156
25	532 41 28-95	Cable Starter
26	532 17 51-58	Fuse
27	873 51 04-00	Nut Keps Hex 1/4-20 unc
28	532 19 88-85	Cable Ground
29	532 40 15-45	Switch Seat
30	532 19 33-50	Switch Ign
33	532 41 19-35	Key/Chain
34	532 11 07-12	Switch Light/Reset
40	532 40 96-14	Harness Ign. Dash/Lift
41	817 72 04-08	Screw Thd Cut 1/4-20 x 1/2
42	532 13 15-63	Cover Terminal Red
43	532 19 25-07	Solenoid
50	532 17 46-53	Switch PTO
55	817 06 05-12	Screw Thdrol 5/16-18 x 3/4
71	532 40 04-49	Ignition Chassis/Lift
79	532 17 52-42	Socket Asm. Bulb
81	532 40 96-15	Relay Harness Sealed
90	532 43 53-95	Cover Terminal Battery
92	532 19 66-15	Harness Pigtail Console ROS
93	532 19 25-40	Screw Plastite 10-14 x 2.0
94	532 19 18-34	Module Reverse ROS

**NOTE:** All component dimensions given in U.S. inches  
1 inch = 25.4 mm

TRACTOR - - MODEL NO. M200-117H (96041022202), PRODUCT NO. 960 41 02-22  
CHASSIS AND ENCLOSURES **39**

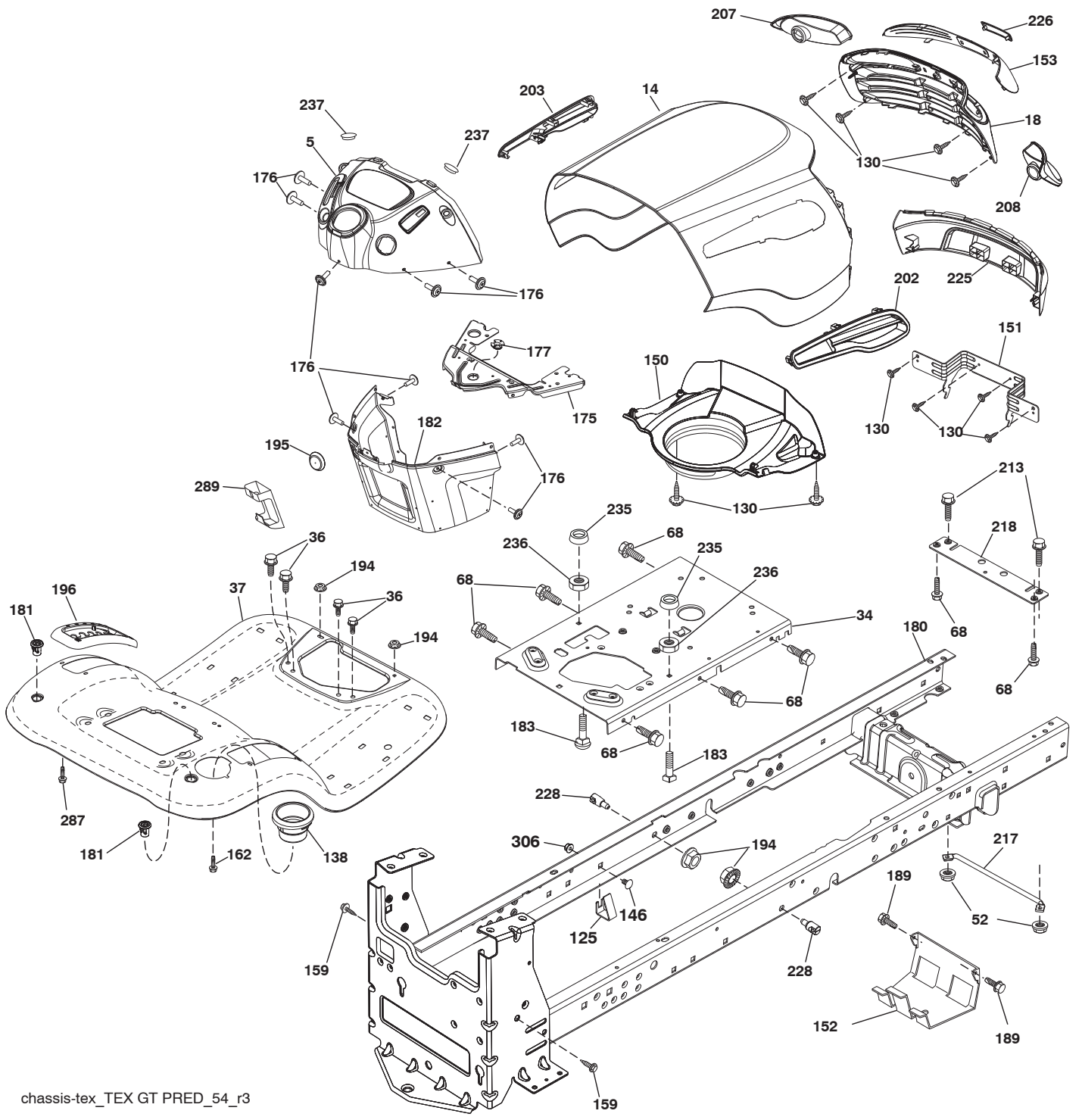

chassis-tex\_TEX GT PRED\_54\_r3

**TRACTOR - - MODEL NO. M200-117H (96041022202), PRODUCT NO. 960 41 02-22  
CHASSIS AND ENCLOSURES **39****

<b>KEY NO.</b>	<b>PART NO.</b>	<b>DESCRIPTION</b>
5	532 42 82-71	Dash
14	532 44 80-42	Hood
18	532 42 73-33	Grille
34	532 44 72-53	Plate Engine
36	817 06 05-12	Screw 5/16-18 x 3/4
37	532 42 09-86	Fender
52	873 68 05-00	Nut Crown Lock 5/16-18
68	817 49 05-08	Screw Thdrol 5/16-18 x 1/2
125	581 68 48-01	Clip Fuel Line
130	532 41 63-58	Screw #10 x 0.750
138	532 40 97-30	Cupholder
146	581 85 79-01	Bolt
150	584 86 29-01	Air Duct
151	532 44 54-94	Bracket Pivot
152	532 19 95-35	Shield Browning
153	532 42 47-17	Lens Bar
159	817 00 06-12	Screw 3/8-16 x 3/4
162	532 14 24-32	Screw Hex WSH Hi Lo 1/4 x 1/2 unc
175	532 19 63-04	Crossmember
176	532 40 07-76	Screw 10-24 x 5/8
177	532 19 52-27	Bushing Steering
180	532 19 54-57	Chassis
181	532 40 47-96	Bushing Mtg. Fender Crgo
182	532 40 68-59	Dash Lower
183	874 52 05-20	Bolt 5/16-18 x 1-1/4
189	817 00 05-12	Screw 5/16-18 x 3/4
194	873 90 05-00	Nut Lock Hex Flange 5/16-18
195	532 40 41-37	Plug Hole Dash Lower
196	532 41 45-81	Console Asm. Deck Lift
202	532 44 80-45	Vent Side RH
203	532 44 80-44	Vent Side LH
207	532 19 89-63	Bezel RH
208	532 19 89-64	Bezel LH
213	874 76 05-12	Bolt Hex HD 5/16-18 unc x 3/4
217	532 40 91-67	Rod Pivot Hood
218	532 19 63-95	X-Piece Hood Stop
225	532 44 80-91	Bumper
226	532 44 80-92	Logo
228	532 19 51-61	Stud Fastner
235	532 40 61-29	Spacer Fender
236	873 93 05-00	Nut Lock 5/16-18 unc
237	532 40 37-04	Plug Mount Cargo
287	817 60 04-06	Screw 1/4-20 x 3/8
289	532 40 35-71	Plug Cruise/Phone Common YTGT
306	873 90 06-00	Nut Lock
--	532 41 17-08	Plug Dash
--	532 40 09-44	Kit Bumper

**NOTE:** All component dimensions given in U.S. inches  
1 inch = 25.4 mm

**TRACTOR -- MODEL NO. M200-117H (96041022202), PRODUCT NO. 960 41 02-22  
DRIVE 40**

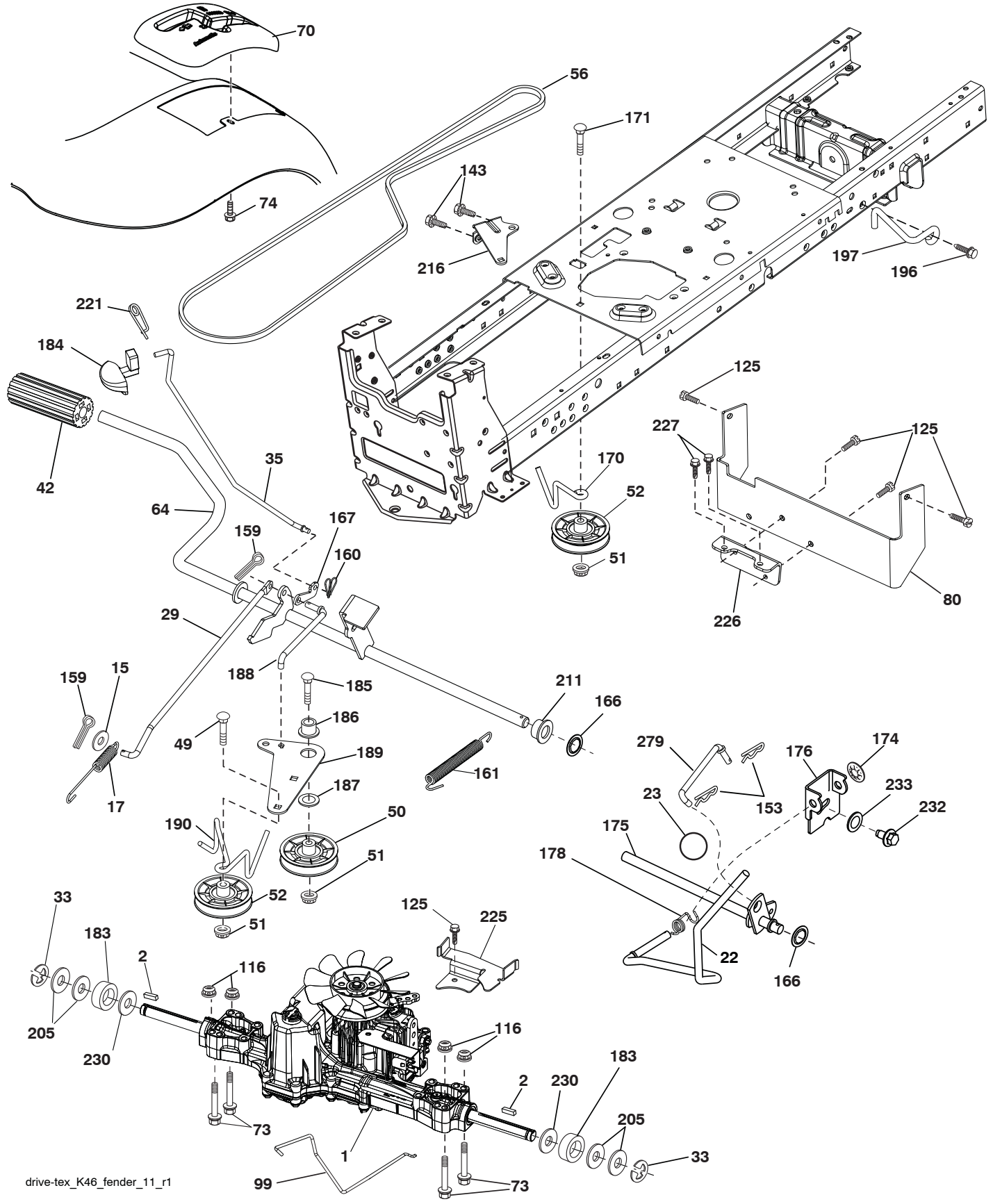

drive-tex\_K46\_fender\_11\_r1



**TRACTOR - - MODEL NO. M200-117H (96041022202), PRODUCT NO. 960 41 02-22  
DRIVE 40**

KEY NO.	PART NO.	DESCRIPTION
1	---	Transaxle, TUFFTORQ K46BA (408214) (Order parts from trans-axle manufacturer.)
2	532 12 35-83	Key
15	819 13 13-16	Washer 13/32 x 13/16 x 16 Ga.
17	532 41 36-78	Spring, Brake
22	532 19 76-60	Rod Shift
23	532 14 08-45	Knob
29	532 40 38-06	Rod, Brake
33	812 00 00-01	Ring E
35	583 86 45-01	Rod, Brake, Park
42	532 12 48-72	Cover, Foot Pedal
49	872 11 06-14	Bolt
50	532 19 43-27	Pulley Idler Flat
51	873 90 06-00	Lock Nut 3/8-16
52	532 19 43-26	Idler V-Groove
56	532 13 09-69	V-Belt, Drive
64	532 19 62-00	Shaft Asm. Pedal Brake Control
70	532 41 19-01	Console
73	874 49 05-40	Bolt 5/16-18 x 2-1/2 Gr. 5
74	532 14 24-32	Screw 1/4 x 1/2
80	532 44 06-19	Strap Torque
99	532 41 57-42	Rod Bypass
116	873 90 05-00	Nut Lock Hex Flange 5/16-18
125	817 00 05-12	Screw 5/16-18 x 3/4
143	817 49 05-08	Screw Thdrol 5/16-18 x 1/2
153	532 12 47-88	Retainer Spring
159	876 02 04-12	Pin Cotter 1/8 x 3/4
160	532 16 94-84	Retainer Clip
161	532 10 57-09	Spring, Return, Clutch
166	532 42 91-64	Nut Push

KEY NO.	PART NO.	DESCRIPTION
167	532 40 52-57	Latch Brake Parking
170	532 19 43-22	Keeper Belt Centerspan
171	872 11 06-16	Bolt RDHD SQNK 3/8-16 unc x 2
174	532 19 72-89	Nut Push
175	532 40 62-08	Shaft Asm Shift
176	532 19 62-14	Arm Clevis Rod Shift
178	532 19 74-56	Spring Shift
183	532 13 70-57	Spacer Split
184	532 44 14-55	Handle Parking Brake
185	872 11 06-22	Bolt Rdhd 3/8-16 unc x 2-3/4 Gr. 5
186	532 19 43-21	Spacer Retainer
187	819 13 32-10	Washer
188	532 19 43-23	Link Clutch Ground Drive
189	532 19 43-17	Bellcrank Ground Drive
190	532 19 43-18	Keeper Bellcrank Ground Drive
196	817 00 06-16	Screw 3/8-16 x 1
197	532 19 58-04	Bracket Clutch Anti-Rotation
205	532 12 17-48	Washer
211	532 19 62-12	Bushing Brake Shaft
216	532 19 61-31	Bracket Pulley Idler
221	532 40 31-87	Retainer Spring Clip Handle
225	532 40 33-19	Keeper Belt Trans.
226	532 40 15-64	Bracket Mount Torque
227	817 49 05-12	Screw 5/16-18 x 3/4
230	532 18 89-67	Washer Hardened
232	874 78 07-16	Bolt 7/16-14 x 1 Gr. 5
233	532 40 52-96	Washer Serrated
279	532 40 62-07	Link Shift

**NOTE:** All component dimensions given in U.S. inches  
1 inch = 25.4 mm

**TRACTOR -- MODEL NO. M200-117H (96041022202), PRODUCT NO. 960 41 02-22**  
**STEERING ASSEMBLY [41]**

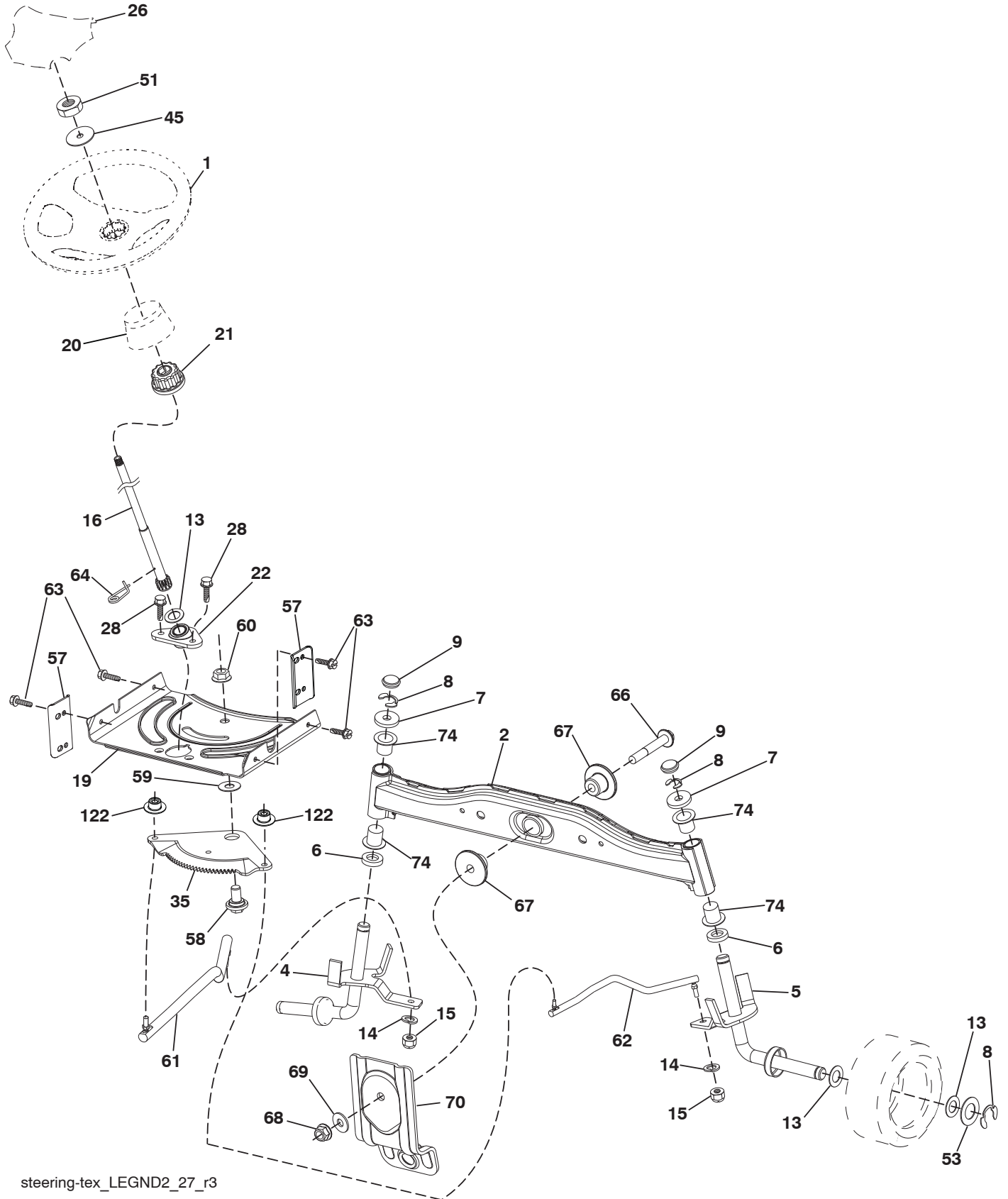

steering-tex\_LEGND2\_27\_r3

**TRACTOR - - MODEL NO. M200-117H (96041022202), PRODUCT NO. 960 41 02-22  
STEERING ASSEMBLY 41**

KEY NO.	PART NO.	DESCRIPTION
1	532 42 41-46	Wheel, Steering
2	532 41 81-68	Axle Asm., Front
4	532 40 30-87	Spindle Asm., LH
5	532 40 30-88	Spindle Asm., RH
6	532 12 49-31	Bearing, Race Thrust Harden
7	532 12 17-48	Washer 25/32 x 1-5/8 x 16 Ga.
8	812 00 00-29	Ring, Clip #T5304-75
9	532 12 12-32	Cap, Spindle
13	532 12 17-49	Washer 25/32 x 1-1/4 x 16 Ga.
14	810 04 06-00	Washer, Lock Hvy Hlcl Spr 3/8
15	873 54 06-00	Nut, Crown Lock 3/8-24 unf
16	532 19 47-46	Shaft Steering
19	532 19 47-29	Plate Steering
20	532 42 47-40	Boot Steering
21	532 18 67-37	Adapter, Wheel Steering
22	532 42 05-37	Steering Support Lower
26	532 42 41-47	Insert, Wheel Steering
28	817 00 06-12	Screw 3/8-16 x 3/4
35	532 19 47-32	Gear, Sector Plate
45	819 18 38-12	Washer 9/16 x 2-3/8 12 Ga.
51	873 94 08-00	Nut Hex Jam Toplock 1/2-20 unf
53	532 18 89-67	Washer Hardened .793 x 1.637 x .060
57	532 40 74-65	Bracket Upstop
58	532 19 47-47	Bolt Shoulder Sector Pivot CFM
59	532 19 47-48	Washer Thrust Sector Steering
60	873 97 10-00	Nut Flange Lock 5/8-11
61	532 19 47-40	Draglink LH
62	532 19 47-41	Draglink, RH
63	817 00 05-12	Screw 5/16-18 x 3/4
64	532 19 98-49	Retainer Clip Spring Steering
66	871 02 07-48	Bolt Hex Fghd 7/16-14 x 3 Serr
67	532 19 47-37	Bushing PM Front Axle
68	873 90 07-00	Nut Lock Flange 7/16-14 Gr. 5
69	532 19 91-62	Washer 1.5 x .505 x .118
70	532 19 61-97	Bracket Deck Susp. Front
74	532 12 49-37	Bearing
122	532 44 49-62	Cap Gear Sector

**NOTE:** All component dimensions given in U.S. inches  
1 inch = 25.4 mm

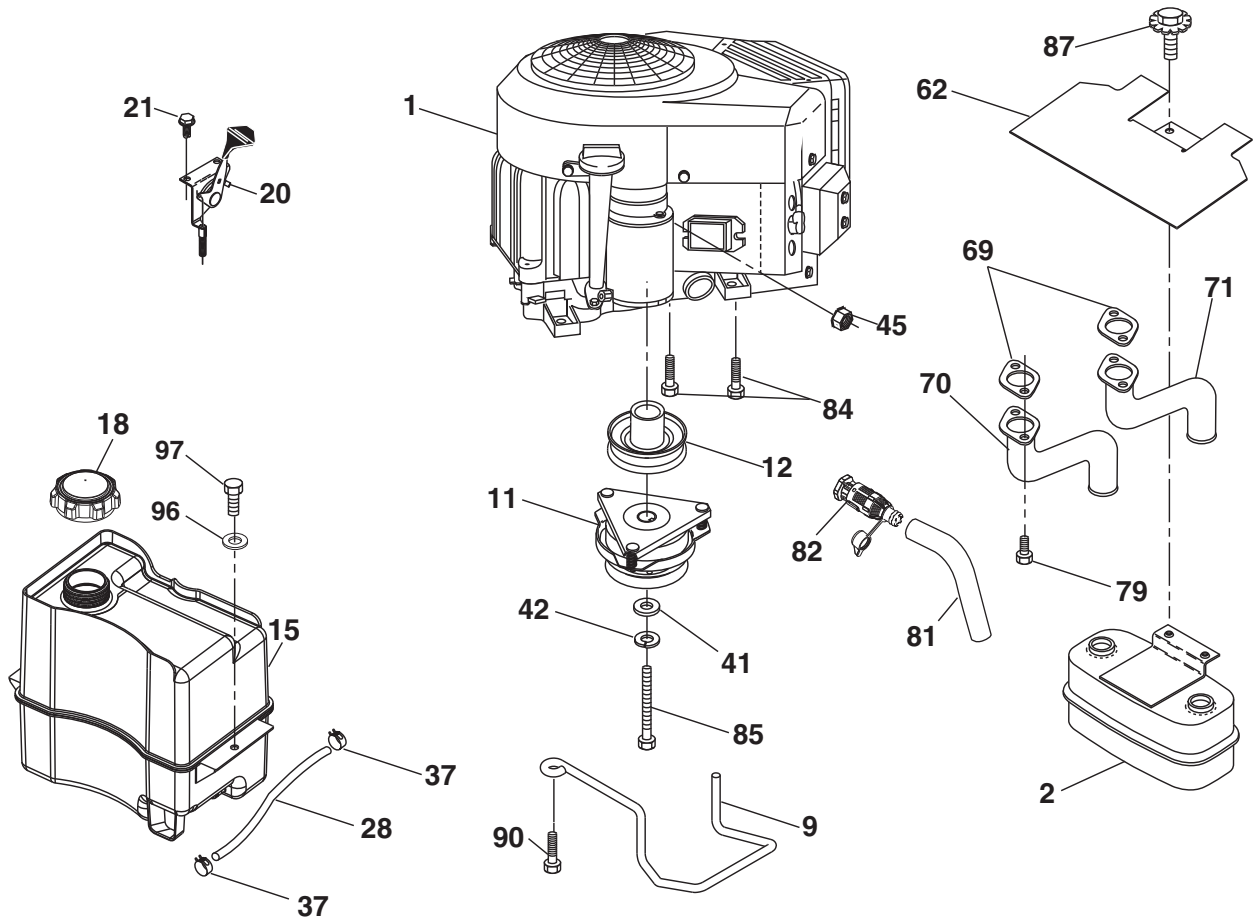

29

**SPARK ARRESTER KIT**

engine-tex\_bs-2cyl\_70

**TRACTOR - - MODEL NO. M200-117H (96041022202), PRODUCT NO. 960 41 02-22  
ENGINE 24**

KEY NO.	PART NO.	DESCRIPTION
1	— — — — —	Engine Briggs Model No. 406777-3216-B1 (438700) (Order parts from engine manufacturer.)
2	532 14 97-23	Muffler
9	532 19 43-20	Keeper Belt Engine
11	532 40 00-08	Clutch Electric
12	532 40 50-97	Pulley Engine
15	532 40 75-51	Tank Fuel
18	532 43 02-20	Cap Asm
20	532 44 65-04	Control Throttle
21	532 41 63-58	Screw #10 x 0.750 BOS Thread
28	532 13 70-40	Fuel Line
29	532 13 71-80	Spark Arrester Kit
37	532 12 34-87	Clamp Hose
41	532 12 61-97	Washer 1-1/2 OD x 15/32 ID x .250
42	810 04 07-00	Washer Lock 7/16
45	873 51 04-00	Nut Keps Hex 1/4-20 unc
62	532 43 40-17	Shield Heat
69	532 16 53-91	Gasket
70	581 88 11-01	Exhaust Tube RH
71	581 88 10-01	Exhaust Tube LH
79	532 18 39-06	Screw 5/16-18 x 1
81	532 14 84-56	Tube Drain Oil Easy
82	532 42 82-87	Valve Oil Drain
84	817 06 06-20	Screw 3/8-16 x 1-1/4
85	532 17 39-37	Bolt 7/16-20 x 4
87	532 17 18-77	Bolt 5/16-18 unc x 3 W/Sems
90	817 00 06-16	Screw 3/8-16 x 1
96	819 09 14-16	Washer 9/32 x 7/8 x 16 Ga.
97	817 67 04-12	Screw 1/4 - 20 x 3/4

**NOTE:** All component dimensions given in U.S. inches  
1 inch = 25.4 mm

**Engine Power Rating Information**

The gross power rating for individual gas engine models is labeled in accordance with SAE (Society of Automotive Engineers) code J1940 (Small Engine Power & Torque Rating Procedure), and rating performance has been obtained and corrected in accordance with SAE J1995 (Revision 2002-05). Torque values are derived at 3060 RPM; horsepower values are derived at 3600 RPM. Actual gross engine power will be lower and is affected by, among other things, ambient operating conditions and engine-to-engine variability. Given both the wide array of products on which engines are placed and the variety of environmental issues applicable to operating the equipment, the gas engine will not develop the rated gross power when used in a given piece of power equipment (actual “on-site” or net power). This difference is due to a variety of factors including, but not limited to, accessories (air cleaner, exhaust, charging, cooling, carburetor, fuel pump, etc.), application limitations, ambient operating conditions (temperature, humidity, altitude), and engine-to-engine variability. Due to manufacturing and capacity limitations, Briggs & Stratton may substitute an engine of higher rated power for this Series engine.

TRACTOR - - MODEL NO. M200-117H (96041022202), PRODUCT NO. 960 41 02-22  
 MOWER DECK **44**

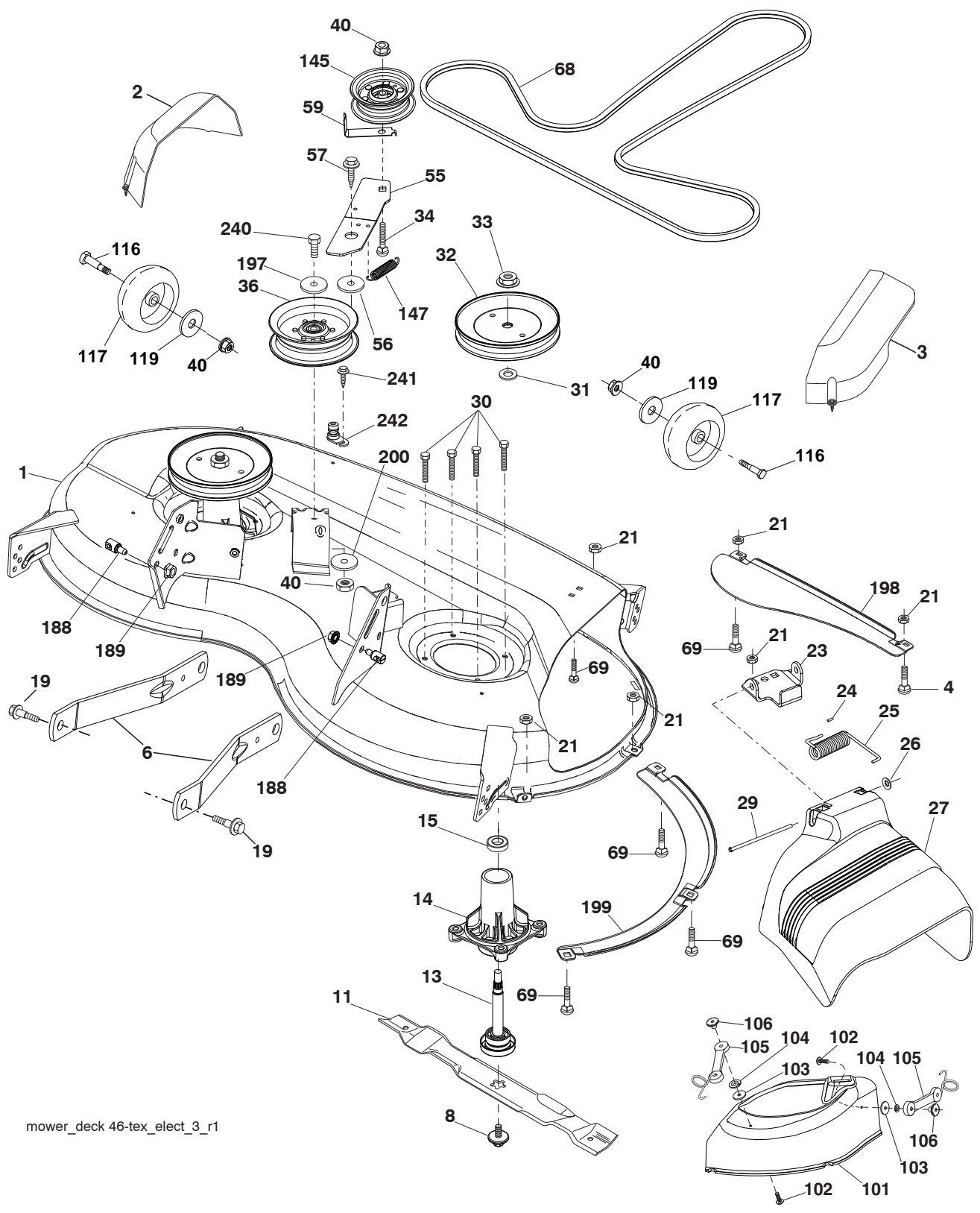

mower\_deck 46-tex\_elect\_3\_r1

**TRACTOR - - MODEL NO. M200-117H (96041022202), PRODUCT NO. 960 41 02-22  
MOWER DECK 44**

KEY NO.	PART NO.	DESCRIPTION	KEY NO.	PART NO.	DESCRIPTION
1	532 44 16-16	Mower Housing	68	532 40 51-43	Belt, Drive
2	532 40 55-06	Cover Mandrel RH	69	872 14 05-05	Bolt
3	532 40 55-07	Cover Mandrel LH	101	532 40 54-54	Cover Mulching
4	874 76 05-12	Bolt Hex Hd 5/16-18 unc	102	871 08 10-10	Screw 10-24 x 5/8
6	532 19 51-86	Arm Suspension	103	819 06 12-16	Washer #10
8	532 19 30-03	Bolt/Washer Asm 7/16-20 unf	104	810 07 10-00	Washer Lock #10
11	532 40 31-07	Blade	105	532 16 07-93	Latch Asm
13	532 19 28-72	Shaft Assembly, Mandrel	106	532 12 50-04	Nut Weld
14	532 18 72-81	Housing, Mandrel	116	532 19 34-06	Bolt, Shoulder
15	532 11 04-85	Bearing, Ball, Mandrel	117	532 17 48-73	Wheel, Gauge
19	532 19 65-39	Bolt, Shoulder	119	819 13 20-12	Washer 13/32 x 1-1/4 x 12 Ga.
21	873 68 05-00	Nut, Crownlock 5/16-18 unc	145	532 19 73-79	Pulley Idler
23	532 19 25-57	Bracket, Deflector	147	532 19 72-51	Spring Mower Drive Electric
24	532 10 53-04	Cap, Sleeve	188	532 19 51-61	Stud Fastener
25	532 19 70-26	Spring, Torsion, Deflector	189	873 90 05-00	Nut Lock Hex Flange
26	532 11 04-52	Nut, Push	197	819 13 13-12	Washer 13/32 x 13/16 x 12 Ga.
27	532 40 53-57	Shield, Deflector	198	532 40 31-49	Baffle Center Front
29	532 13 14-91	Rod, Hinge	199	532 40 31-50	Baffle Front RH
30	532 17 39-84	Screw Thdrol Rolling Wsh Hd	200	532 41 35-24	Washer 13/32 x 1 x 1/2 x 11 Ga.
31	532 18 76-90	Washer, Spacer	240	874 52 06-36	Bolt Fin Hex 3/8-16 x 2-1/4 Gr. 5
32	532 19 74-73	Pulley, Mandrel	241	532 15 29-27	Screw #10-32.5 3/8 Flange
33	532 40 02-34	Nut, Toplock, Flanged	242	532 41 55-98	Port Washout
34	872 11 06-12	Bolt Carr Sh. 3/8-16 x 1-1/2 Gr. 5	--	532 19 28-70	Mandrel Assembly (Includes housing, shaft and shaft hardware only-pulley not included)
36	532 19 31-97	Pulley, Idler, Primary	--	580 37 41-01	Replacement Mower, Complete
40	873 90 06-00	Nut, Lock Flg. 3/8-16 unc			
55	532 19 72-49	Arm, Idler			
56	532 19 90-92	Spacer, Retainer			
57	817 00 06-16	Screw 3/8-16 x 1			
59	532 14 10-43	Guard, Tuv Idler			

**NOTE:** All component dimensions given in U.S. inches  
1 inch = 25.4 mm

**TRACTOR -- MODEL NO. M200-117H (96041022202), PRODUCT NO. 960 41 02-22**  
**MOWER LIFT 45**

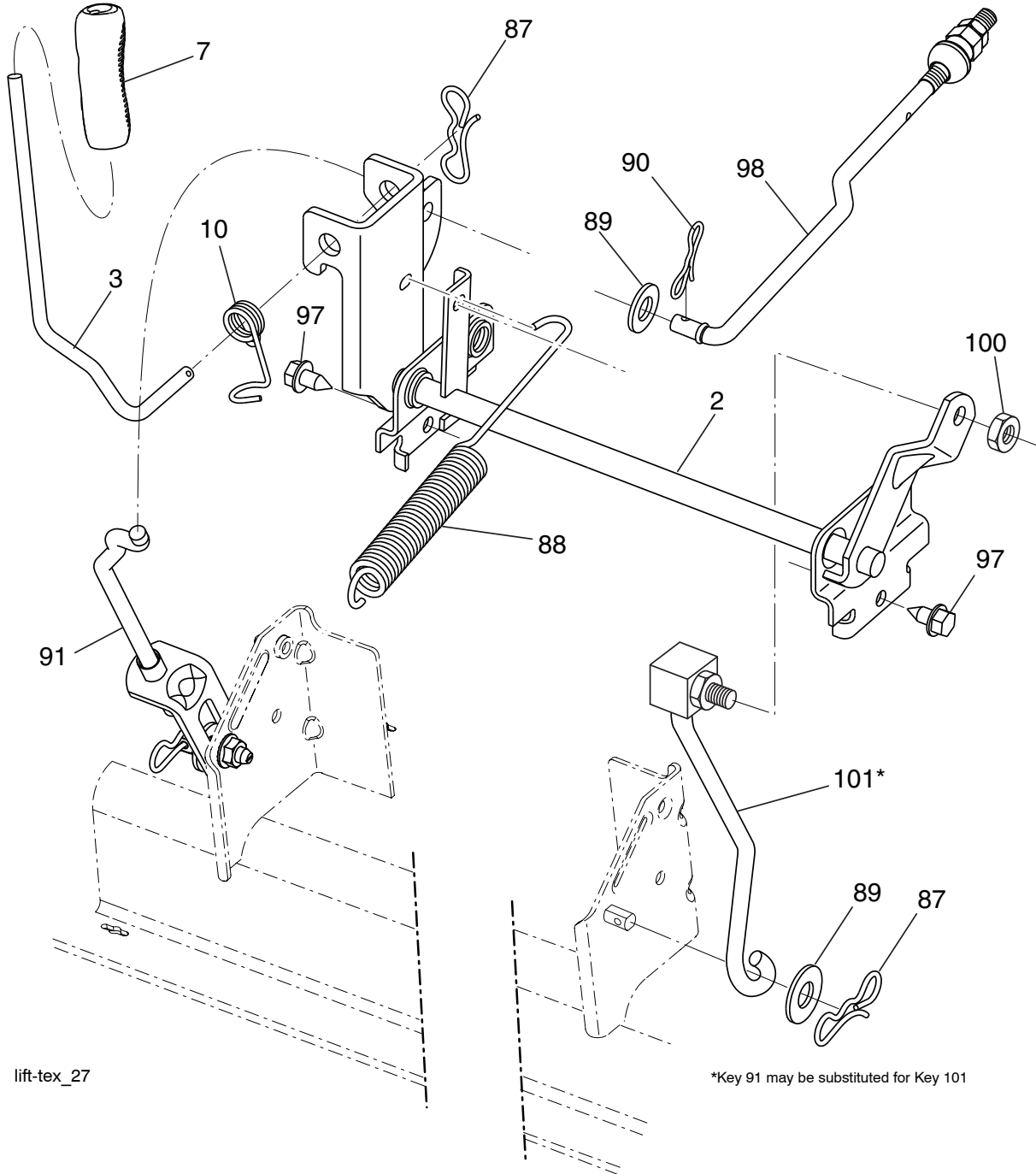

KEY NO.	PART NO.	DESCRIPTION
2	532 42 20-27	Shaft Asm., Lift
3	532 19 52-31	Lever Asm., Lift RH
7	532 41 15-55	Grip, Lever
10	532 19 63-14	Spring Torsion
87	532 19 42-09	Pin Cotter 7/16 Bow Tie Lock
88	532 41 07-10	Spring Lift Assist
89	819 19 19-12	Washer 17/32 x 1-3/16 x 12 Ga.
90	532 19 42-08	Pin Cotter 5/16 Bow Tie Lock

KEY NO.	PART NO.	DESCRIPTION
91	532 19 51-81	Link Lift Susp Mower Rear
97	817 00 06-12	Screw 3/8-16 x .75
98	532 19 52-70	Link Lift Susp. Front Mower
100	873 93 06-00	Nut Centerlock 3/8-16
101	532 40 70-03	Link Asm. Lift FXD

**NOTE:** All component dimensions given in U.S. inches  
 1 inch = 25.4 mm



**TRACTOR - - MODEL NO. M200-117H (96041022202), PRODUCT NO. 960 41 02-22  
SEAT ASSEMBLY 42**

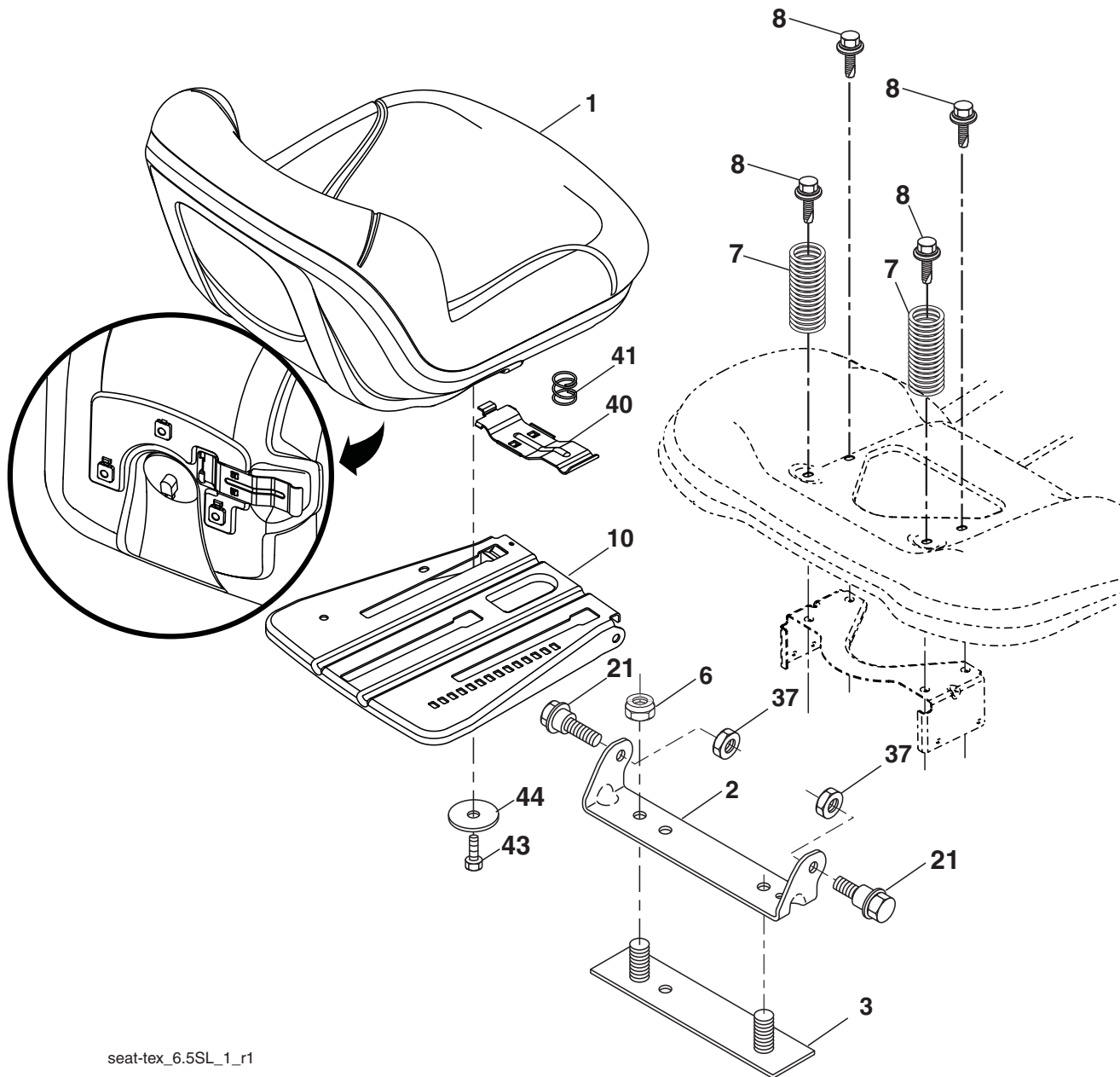

seat-tex\_6.5SL\_1\_r1

KEY NO.	PART NO.	DESCRIPTION
1	532 40 66-25	Seat
2	532 18 01-66	Bracket Pivot Fender
3	532 14 06-75	Strap, Asm Fender
6	873 80 06-00	Nut, Lock w/Ins. 3/8-16 unc
7	532 12 41-81	Spring, Seat Cprsn
8	532 17 18-77	Bolt 5/16-18 unc x 3/4 w/Sems
10	532 19 69-77	Pan, Seat
21	532 17 18-52	Bolt, Shoulder 5/16-18

KEY NO.	PART NO.	DESCRIPTION
37	873 80 05-00	Nut, Lock 5/16-18 unc
40	532 19 76-61	Handle Slide Seat
41	532 19 82-00	Spring Latch Seat
43	874 76 06-12	Bolt 3/8-16 x 3/4
44	819 13 38-12	Washer 13/32 x 2-3/8 x 12 Ga.

**NOTE:** All component dimensions given in U.S. inches  
1 inch = 25.4 mm

