

# **ILLUSTRATED PARTS LIST**

**MODEL NO. 96021001900**

**CUSTOMER CATALOG NO. M105-77XC**

**PRODUCT NO. 960 21 00-19**

**RIDING MOWER--MODEL NO. M105-77XC (96021001900), PRODUCT NO. 9602100-19  
DECALS 27**

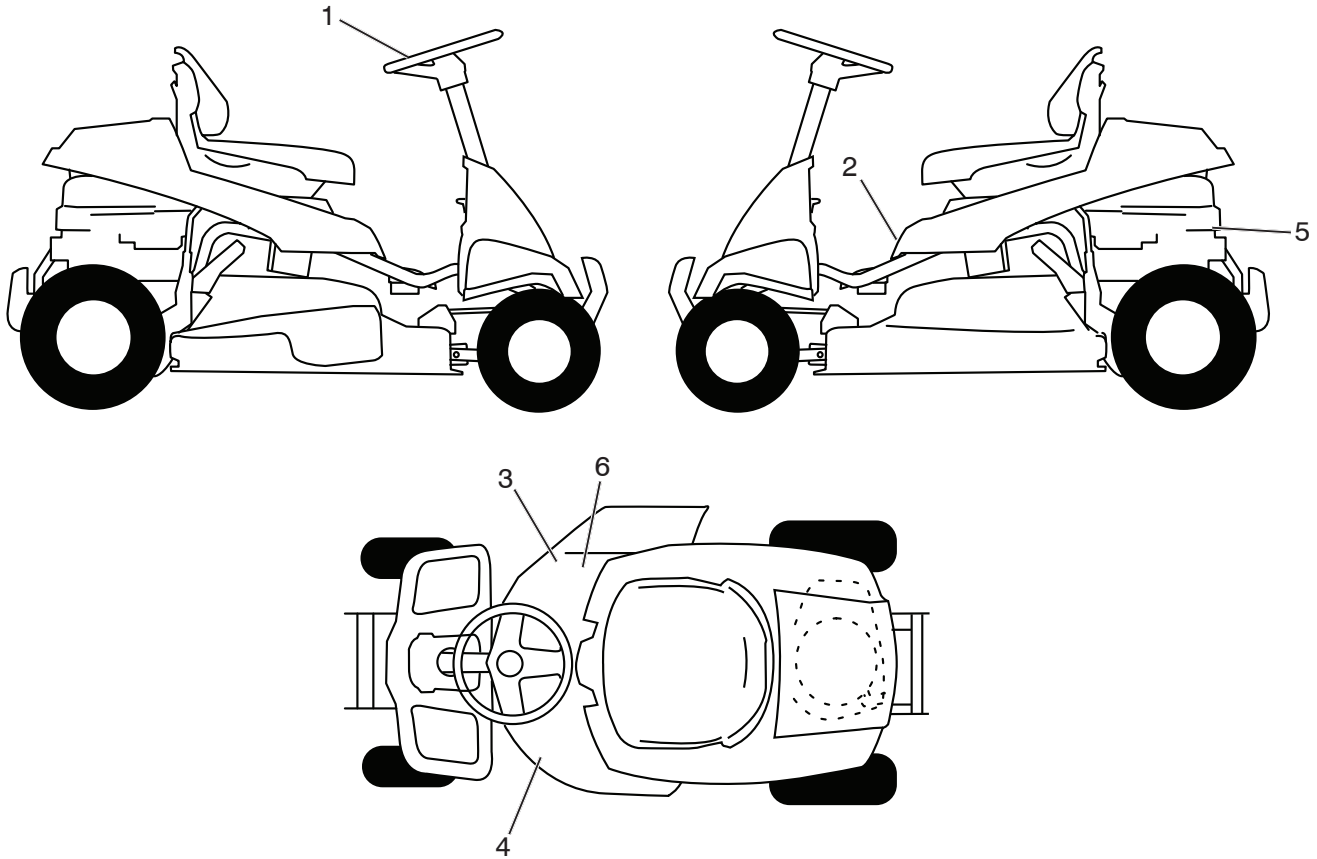

KEY NO.	PART NO.	DESCRIPTION
1	532 43 79-66	DECAL, STEERING WHEEL
2	532 19 97-32	DECAL, NOISE LEVEL
3	532 44 75-48	DECAL, DECK
4	532 42 51-12	DECAL, WARN. DEFLECT/CTFGR
5	532 43 74-08	DECAL, ENGINE H.P.
6	532 44 14-97	DECAL, V-BELT SCH 30"
--	532 44 75-39	MANUAL OPER.MCC.EURO
--	532 44 80-51	MANUAL OPER.MCC.SCAN
--	532 44 80-52	MANUAL OPER.MCC.EBLOC
--	532 44 80-53	MANUAL OPER.MCC.BALT
--	532 44 75-40	MANUAL PARTS.MCC.

**NOTE:** All component dimensions given in U.S. inches  
1 inch = 25.4 mm

# RIDING MOWER--MODEL NO.M105-77XC (96021001900), PRODUCT NO.9602100-19 SCHEMATIC 38

SCH24

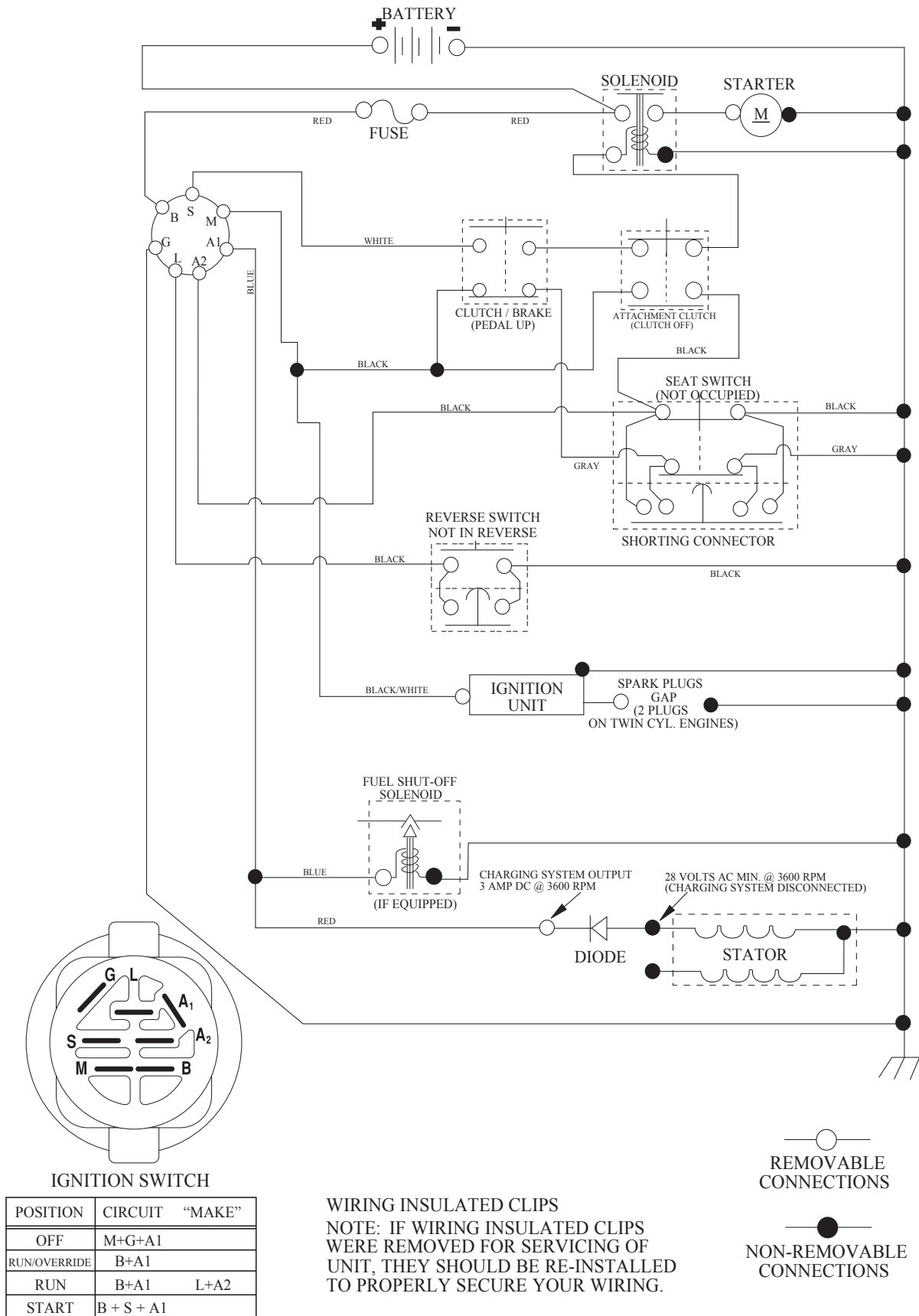



**RIDING MOWER--MODEL NO.M105-77XC (96021001900), PRODUCT NO.9602100-19  
ELECTRICAL 32**

<b>KEY NO.</b>	<b>PART NO.</b>	<b>DESCRIPTION</b>
1	532 43 65-51	BATTERY
3	532 19 33-50	SWITCH, IGN, DLTA, P-IN, ROS
4	532 41 19-33	KEY/CHAIN
9	532 10 95-53	SWITCH, INTLK,CL, MWR, GRY
10	532 17 61-38	SWITCH, INTERLOCK, NONC,GRAY
12	532 19 27-49	SWITCH, SEAT, DP, ROS
13	532 43 72-28	HARNESS, IGN, ELECTSTART, LRV
15	532 19 25-07	SOLENOID
16	817 72 04-08	SCREW THD CUT 1/4-20 X 1/2 TY23
17	873 51 04-00	NUT KEPS HEX 1/4-20 UNC
18	532 41 66-94	CABLE BATTERY
19	532 42 12-99	CABLE STARTER
20	532 42 12-98	CABLE GROUND
21	817 06 05-12	SCREW 5/16-18 X 3/4
22	532 44 21-48	SCREW HEX M5X0.8.9MM
23	532 43 81-22	NUT M5
24	818 10 10-12	SCREW TORX #10-14 X .750
25	532 43 48-99	FUSE, 10

**NOTE:** All component dimensions given in U.S. inches  
1 inch = 25.4 mm

**RIDING MOWER--MODEL NO. M105-77XC (96021001900), PRODUCT NO. 9602100-19**  
**CHASSIS AND ENCLOSURES 39**

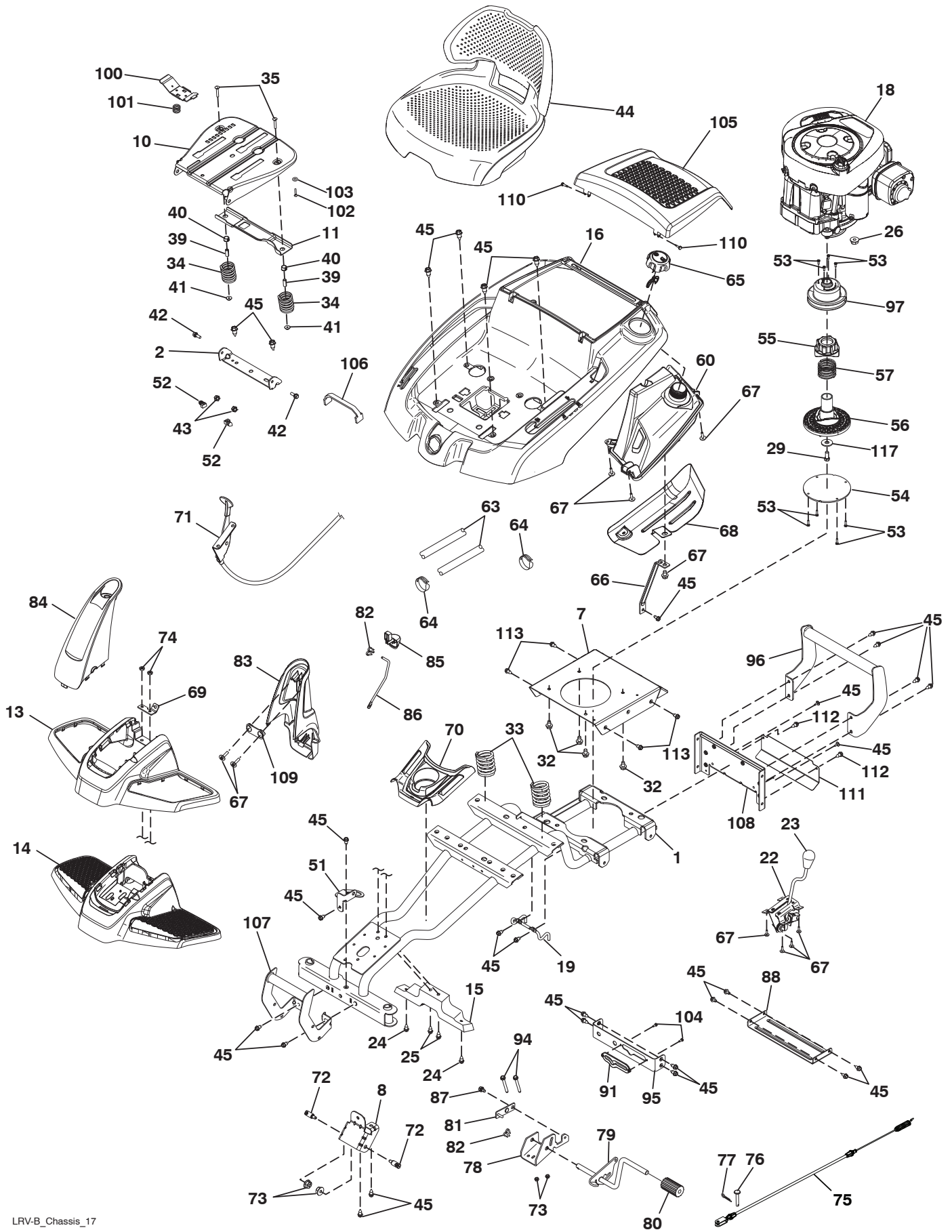

**RIDING MOWER--MODEL NO. M105-77XC (96021001900), PRODUCT NO. 9602100-19  
CHASSIS AND ENCLOSURES 39**

KEY NO.	PART NO.	DESCRIPTION	KEY NO.	PART NO.	DESCRIPTION
1	532 43 61-76	WELDMENT, CHASSIS	69	532 43 74-27	BRACKET MOUNT CABLE
2	532 18 01-66	BRACKET, SEAT	70	532 44 20-68	CONSOLE CENTER CUPHOLDER
7	532 43 61-77	PLATE, ENGINE	71	532 43 78-57	THROTTLE ASM
8	532 43 68-60	BRACKET, CHASSIS FRONT	72	532 19 51-61	STUD FASTNER
10	532 44 18-05	PAN, SEAT	73	873 90 05-00	NUT LOCK HEX FLANGE 5/16-18
11	532 19 93-70	BRACKET, SWITCH MOUNTING	74	873 90 04-00	NUT HEX FLANGE 1/4-20
13	532 44 20-71	COVER, FOOT REST	75	532 43 69-59	CABLE BRAKE
14	532 44 20-75	FOOTREST STRUCTURAL	76	877 10 08-12	PIN CLEVIS
15	532 44 20-69	SUPPORT, FOOT REST	77	876 02 02-08	PIN COTTER 1/16 X 1/2
16	532 43 93-95	PANEL ASM, CONTROL	78	532 43 70-56	BRACKET SUPPORT ROD
18	-----	ENGINE, 215807-0335-B1 (447265) (NON-CALIFORNIA) (ORDER PARTS FROM ENGINE MANUFACTURER.)	79	532 43 70-57	BRAKE WELDMENT
19	532 43 68-61	KEEPER, BELT	80	532 42 96-93	BRAKE PEDAL COVER
22	532 44 21-30	DECK CLUTCH ASM	81	532 43 73-74	WELDMENT LINK CONNECTING
23	532 14 98-46	KNOB	82	532 16 94-84	RETAINER CLIP
24	532 41 63-58	SCREW #10 X 0.750 BOS THREAD	83	532 43 93-67	STEERING TOWER REAR
25	872 14 04-24	BOLT	84	532 43 92-88	STEERING BOOT FRONT
26	873 51 04-00	NUT 1/4-20	85	532 43 76-60	PARKING BRAKE HANDLE
29	532 43 89-21	BOLT, 7/16-20 X 1.00	86	532 43 87-62	ACTUATOR PARKING BRAKE
32	817 06 06-20	SCREW 3/8-16 X 1-1/4	87	532 16 54-92	SHOULDER BOLT
33	532 12 41-81	SPRING, SEAT	88	532 42 81-10	CROSS BRACE
34	532 12 37-40	SPRING	91	532 43 74-01	TRACK CLUTCH BRKT
35	872 05 04-12	BOLT, 1/4-20 X 1 1/2	94	874 49 05-48	BOLT
39	532 13 43-00	SPACER	95	532 44 42-71	BRACKET CLUTCHING
40	532 12 12-48	BUSHING, NYLON SNAP	96	532 44 20-73	BUMPER REAR
41	532 12 39-76	NUT, LOCK	97	532 43 64-72	PULLEY ENGINE
42	532 17 18-52	BOLT, 5/16-18 SHOULDER	100	532 19 76-61	HANDLE SLIDE SEAT
43	873 80 05-00	NUT, 5/16-18	101	532 19 82-00	SPRING LATCH SEAT
44	532 43 66-12	SEAT	102	874 76 06-12	BOLT FIN HEX 3/8-16 UNC X 3/4
45	817 06 05-16	SCREW 5/16-18 X 1 SMGML.	103	819 13 38-12	WASHER 13/32 X 2 3/8 X 12 GA
51	532 42 88-56	BRACKET	104	818 10 10-08	SCREW TORK #10-14 X 1/2
52	532 14 50-06	CLIP PUSH-IN HINGED	105	532 44 20-78	ENGINE COVER
53	532 43 85-62	SCREW	106	532 43 68-34	STRAP BATTERY
54	532 43 64-73	DISC FRICTION	107	532 44 20-74	FRONT BRUSH GUARD
55	532 43 58-08	TORSION BODY UPPER	108	532 43 71-68	COVER REAR TRANSAXLE
56	532 44 19-25	TORSION BODY LOWER	109	532 43 90-08	BRAKE HANDLE PLATE
57	532 43 64-79	SPRING HELIX	110	532 42 21-45	CONTROL PANEL HINGE PIN
60	532 43 78-58	FUEL TANK ASM	111	532 43 81-71	SHIELD, BRAKE CABLE
63	532 41 41-19	PURGE LINE	112	817 72 04-08	SCREW THD CUT
64	532 12 34-87	CLAMP HOSE	113	817 06 05-12	SCREW 5/16-18 X 3/4
65	532 43 85-96	FUEL CAP	117	532 19 91-62	WASHER 1.5 X .50 X .118
66	532 43 66-06	FUEL TANK SUPPORT BRKT			
67	532 42 17-56	SCREW #10 X 0.500			
68	532 43 98-51	SHIELD HEAT			

**NOTE:** All component dimensions given in U.S. inches  
1 inch = 25.4 mm

RIDING MOWER--MODEL NO. M105-77XC (96021001900), PRODUCT NO. 9602100-19  
DRIVE **40**

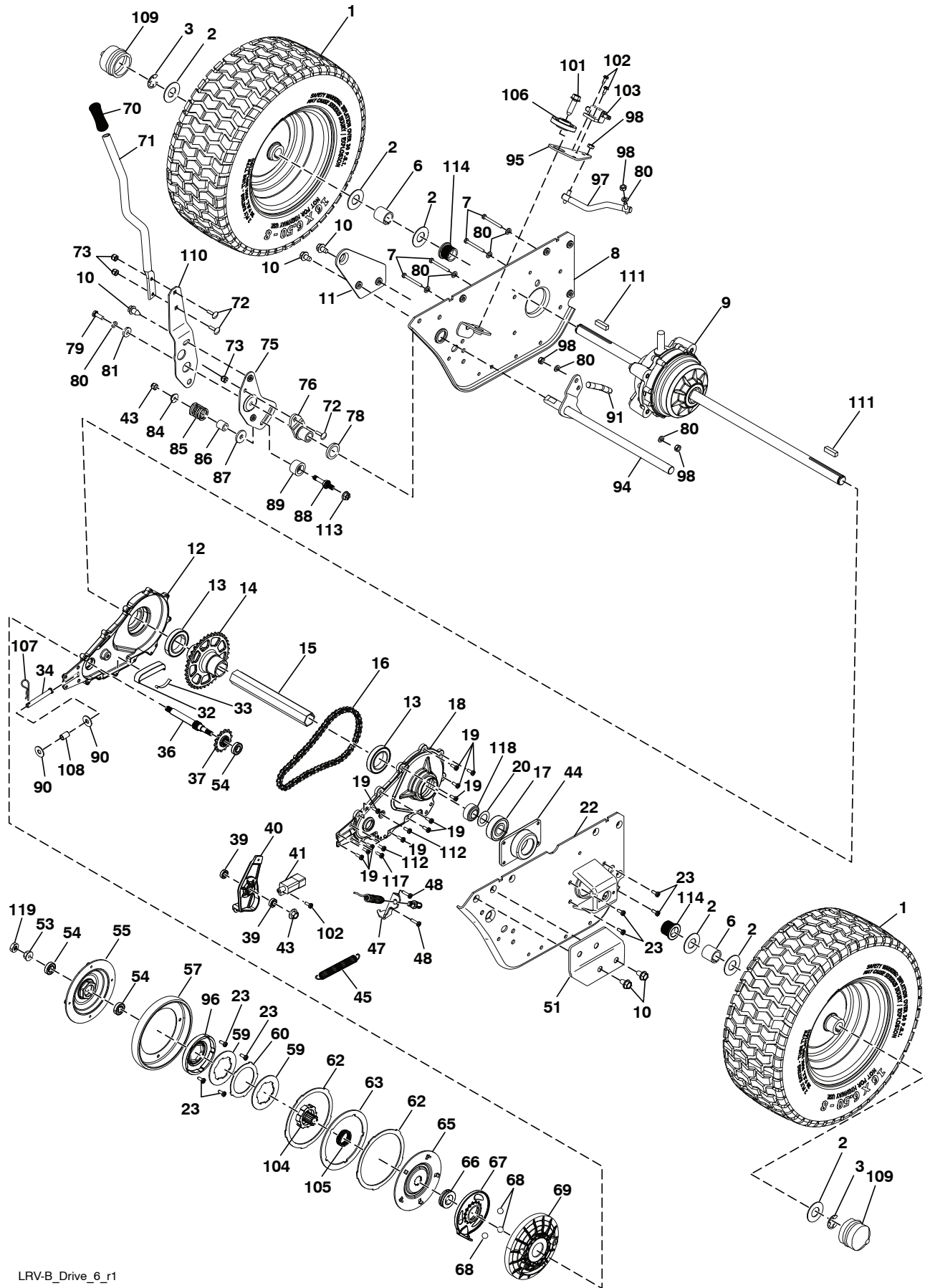



**RIDING MOWER--MODEL NO.M105-77XC (96021001900), PRODUCT NO.9602100-19  
DRIVE 40**

KEY NO.	PART NO.	DESCRIPTION	KEY NO.	PART NO.	DESCRIPTION
1	532 44 20-79	WHEEL ASM (REAR)	68	532 44 58-17	BEARING BALL LOOSE
2	532 12 17-48	WASHER, 16 GA.	69	532 44 58-16	COVER CLUTCH
3	812 00 00-01	E-CLIP	70	580 96 23-01	GRIP LEVER
6	532 15 69-72	SPACER AXLE	71	532 43 68-65	TUBE SHIFT LRV
7	874 78 04-28	HCS 1/4-20 X 1-3/4 GR 5 ZD	72	872 11 04-06	BOLT CARR.
8	532 43 66-95	WELMENT SUPPORT AXLE RH	73	873 68 04-00	NUT CROWNLOCK 1/4 - 20 UNC
9	532 44 39-89	SUBASM FINAL DRIVE	75	532 43 67-58	BRACKET MOUNT SHIFT
10	817 00 05-12	SCREW 5/16 - 18 X 3/4	76	532 44 43-04	HUB SHIFT
11	532 43 67-41	BRACKET.SUPPORT.RH	78	532 42 90-55	SPACER NYLON .866 X 1.25 X .250
12	532 44 74-24	CASE CHAIN RH	79	874 78 04-12	BOLT.FIN.HEX.1/4-20 UNC X .75
13	532 43 72-80	BEARING BALL 6207-SRS	80	810 04 04-00	WASHER LOCK HVY HLCL SPRING
14	532 43 71-76	SPROCKET DRIVEN 37 TOOTH	81	819 09 12-10	WASHER 9/32 X 3/4 X 10 GA.
15	532 44 29-53	TUBE INPUT HEX	84	819 11 16-10	WASHER 11/32 X 1.00 X 10 GA.
16	532 43 61-53	CHAIN PRIMARY DRIVE	85	532 43 69-14	SPRING FRICTION PACK
17	532 43 72-82	BEARING BALL 6204-3-2RS	86	532 43 73-04	BUSHING PACK FRICTION FD2
18	532 43 61-49	CASE CHAIN LH	87	532 43 69-48	WASHER PLASTIC
19	818 05 10-10	SCREW 10 - 24 X 5/8 PAN HEAD TORX	88	532 43 67-01	STUD PACK FRICTION
20	532 12 49-31	WASHER THRUST .75 X 1.230	89	532 43 72-99	SPACER PACK FRICTION FD2
22	532 43 66-96	WELMENT SUPPORT AXLE LH	90	819 11 14-16	WASHER.11/32 X 7/8 X 16 GA.
23	818 05 10-10	SCREW TORX #10 - 14 X 1/2	91	532 43 69-24	SUBASM.LINK.SHIFT
32	532 43 61-51	BLOCK TENSION CHAIN	94	532 43 69-18	WELDMENT.SHIFT.FD2
33	532 43 61-50	SPRING ADJUSTER TENSION	95	532 43 68-66	PLATE.SHIFT
34	877 10 10-40	PIN CLEVIS 5/16 X 2-1/2	96	532 44 47-17	DRUM CLUTCH MULTI DISC
36	532 44 62-78	SHAFT INPUT CLUTCH	97	532 43 69-25	SUBASM LINK SHIFT PRIMARY
37	532 43 61-52	SPROCKET SPLINED 14 TOOTH	98	532 15 03-60	NUT LOCK CENTER 1/4 - 28 FNTHD
39	532 43 04-70	BEARING BALL	101	817 06 06-24	SCREW.3/8-16X1-1/2. SMGML.TAP/R
40	532 43 69-39	ARM BRAKE	102	532 08 67-77	THREAD.CUTTER
41	532 10 95-53	SWITCH INTLK CL MWR GRY 4 TERM	103	532 10 44-45	SWITCH.SEAT.
43	873 80 05-00	NUT LOCK HEX W/INSERT 5/16 - 18 UNC	104	532 44 47-15	HUB CENTER
44	532 43 66-52	COVER END HEX	105	532 43 61-42	SPRING WAVE C125-H5
45	532 43 61-54	SPRING DRIVE	106	532 19 43-21	SPACER RETAINER
47	532 43 69-49	BRACKET MOUNT CABLE LRV B	107	532 12 47-88	RETAINER.SPRING.1".ZINC/CAD
48	817 54 10-16	SCREW.HEX.HEAD WASH.10-24X1.00	108	532 43 67-84	BUSHING.5/16IDX7/16ODX1/2
51	532 43 67-39	BRACKET SUPPORT LH	109	532 19 32-68	CAP.HUB.AXLE.1.50 X 1.00
53	873 90 06-00	LOCK NUT, FLANGED	110	532 42 84-61	BRACKET SHIFTER FLEX
54	532 43 57-26	BEARING BALL	111	532 12 35-83	KEY.SQUARE.2.0 X .1845/.1865
55	532 44 47-16	COVER WHEEL CLUTCH	112	818 10 10-12	SCREW TORX #10-14 X .750
57	532 43 65-59	WHEEL FRICTION	113	873 90 05-00	NUT LOCK FLANGE HEX
59	532 44 10-97	PLATE.CLUTCH.DRIVE	114	532 43 62-82	BEARING FLANGE
60	532 43 77-87	PLATE PRESSURE DRIVE	117	532 44 26-00	SCREW.TORX.SHOULDER
62	532 43 77-86	PLATE CLUTCH BRAKE	118	532 44 25-01	CAP.TUBE.HEX
63	532 43 77-85	PLATE PRESSURE BRAKE	119	873 35 06-00	NUT.HEX 3/8-16 UNC
65	532 44 58-14	PLATE PRESSURE MASTER			
66	532 43 57-24	BEARING THRUST 20MM			
67	532 44 58-15	PLATE THROWOUT			

**NOTE:** All component dimensions given in U.S. inches  
1 inch = 25.4 mm



**RIDING MOWER--MODEL NO.M105-77XC (96021001900), PRODUCT NO.9602100-19  
STEERING ASSEMBLY **41****

KEY NO.	PART NO.	DESCRIPTION
1	532 44 20-64	WHEEL TUBE
2	812 00 00-01	E-CLIP
3	532 18 89-67	WASHER, HARDENED
4	532 12 17-49	WASHER, 1/4 X 3/4
5	532 43 61-81	SPINDLE, RH
6	532 12 49-31	WASHER, HARDENED THRUST
7	532 12 49-37	BUSHING, STEERING COLUMN
9	819 13 14-14	WASHER
10	532 42 80-57	WELDMENT, LWR STRG SHAFT
11	532 43 61-83	LINK, STRNG LH
12	532 43 61-84	LINK, STRNG RH
13	874 78 05-24	BOLT, 5/16-18 X 1 1/2
14	819 11 12-16	WASHER 11/32 X 3/4 X 16 GA
16	532 42 87-94	BUSHING SNAP
15	873 80 05-00	NUT, 5/16-18
17	532 43 61-78	SUPPORT, UPPER STEERING
19	817 00 05-12	BOLT, 5/16-18 X 3/4
20	532 42 80-45	CLIP, RETAINER SPRING
23	532 43 77-47	ADAPTER, STEERING WHEEL
26	532 42 45-51	WHEEL, STEERING
27	532 44 15-06	CAP, STEERING WHEEL
28	532 19 98-49	CLIP, RETAINER SPRING
29	532 43 61-80	SPINDLE LH
30	532 19 32-68	CAP, HUB, AXLE
31	819 34 32-10	WASHER 1-1/16 X 2 X 10GA.
32	817 58 05-20	SCREW HEXWSH THD 5/16-18 X 1-3/4
34	532 44 49-80	SHAFT STEERING
35	532 44 20-66	BOOT LOWER STEERING WHEEL
36	532 44 49-81	SHAFT EXTENSION STEERING SPLINE
37	847 80 51-04	BOLT FIN HEX 5/16-18 UNC X 5 GR5
38	810 04 05-00	WASHER LOCK HVY HLCL SPR 5/16
39	819 11 38-12	WASHER
41	532 43 65-90	FOAM SHAFT STEERING
42	532 42 10-76	PIN, 5/64 X 3/4 COTTER
43	873 54 05-00	CROWNLOCK NUT 5/16-24 UNF
44	532 42 80-44	BUSHING

**NOTE:** All component dimensions given in U.S. inches  
1 inch = 25.4 mm

RIDING MOWER-- MODEL NO. M105-77XC (96021001900), PRODUCT NO. 9602100-19  
MOWER DECK 44

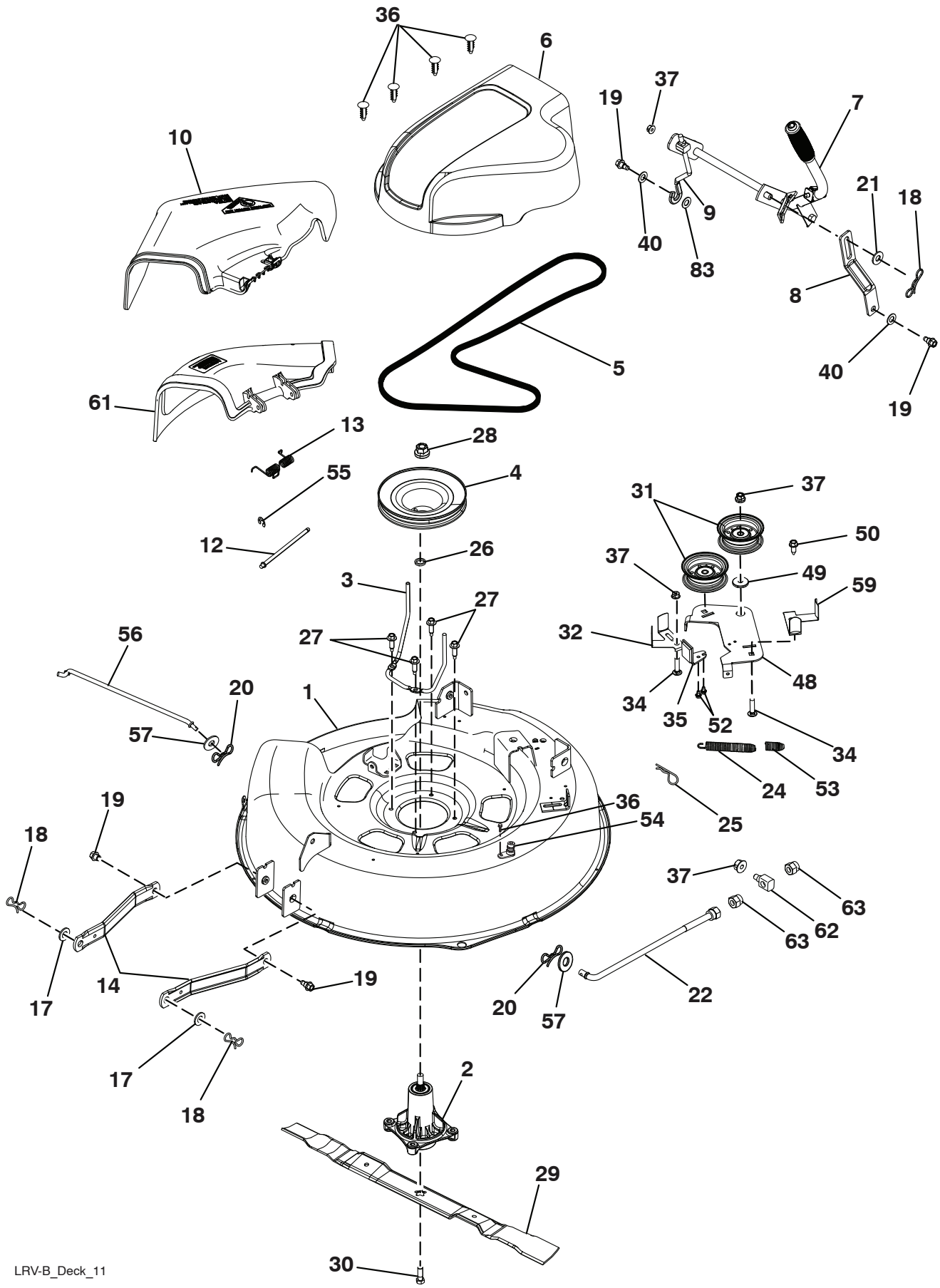

**RIDING MOWER--MODEL NO.M105-77XC (96021001900), PRODUCT NO.9602100-19  
MOWER DECK 44**

<b>KEY NO.</b>	<b>PART NO.</b>	<b>DESCRIPTION</b>
1	532 43 68-48	DECK
2	532 19 28-70	MANDREL ASM
3	532 43 68-56	KEEPER, BELT
4	532 43 68-55	PULLEY, MANDREL
5	532 44 15-97	BELT
6	532 43 68-63	COVER, MANDREL
7	532 43 67-34	LIFT ASM, DECK
8	532 42 91-95	LINK LIFT FIXED
9	532 42 93-97	LINK ASM. LIFT ADJUSTABLE
10	532 43 96-38	DEFLECTOR
12	532 43 66-47	PIN, HINGE
13	532 43 74-62	SPRING, TORSION
14	532 19 51-85	ARM, MOWER SUPPORT
17	819 19 19-12	WASHER
18	532 19 42-09	PIN
19	532 19 65-39	BOLT, SHOULDER
20	532 19 42-08	PIN COTTER 5/16 BOW TIE LOCK
21	819 17 19-12	WASHER 17/32 X 1-3/16 X 12 GA.
22	532 44 15-98	LINK ASM DECK
24	532 40 18-72	SPRING.RETURN.DECK
25	532 12 47-88	RETAINER SPRING 1"
26	532 18 76-90	SPACER, MANDREL
27	532 17 39-84	BOLT, MANDREL
28	532 40 02-34	NUT FLANGE LOCK TOP
29	532 44 62-81	BLADE
30	532 19 30-03	BOLT, BLADE
31	532 19 31-97	PULLEY, IDLER
32	532 14 10-43	GUARD, IDLER TUV
34	872 11 06-12	BOLT, 3/8-16 X 1 1/2
35	532 19 94-70	ARM, BRAKE
36	532 13 77-29	SCREW THD ROLL 1/4-20 X 5/8
37	873 90 06-00	NUT, 3/8-16 FLANGE
40	819 17 16-16	WASHER, 16 GA.
48	586 79 41-01	ARM CLUTCHING
49	532 19 90-92	SPACER RETAINER
50	817 00 06-16	SCREW 3/8-16 X 1
52	817 60 04-06	SCREW 1/4-20 X 3/8
53	532 40 18-72	SPRING RETURN DECK
54	532 41 55-98	PORT WASHOUT
55	532 43 79-88	E-RING 5/16
56	532 43 68-62	ROD ANTI-SWAY
57	819 13 13-12	WASHER 13/32 X 13/16 X 12 GA.
59	532 43 68-58	GUARD TUV IDLER
61	532 43 79-47	MULCH COVER ASM
62	532 17 62-05	TRUNION SUSPENSION ARM
63	532 17 59-94	NUT LIFT LINK 7/16-20
83	819 12 14-14	WASHER 3/8 X 7/8 X 14 GA.

**NOTE:** All component dimensions given in U.S. inches  
1 inch = 25.4 mm

