

ILLUSTRATED PARTS LIST

MODEL NO. 96021001401

CUSTOMER CATALOG NO. 960210014

PRODUCT NO. 960 21 00-14

**RIDING MOWER - - MODEL NO. 960210014 (96021001401), PRODUCT NO. 960 21 00-14
DECALS **27****

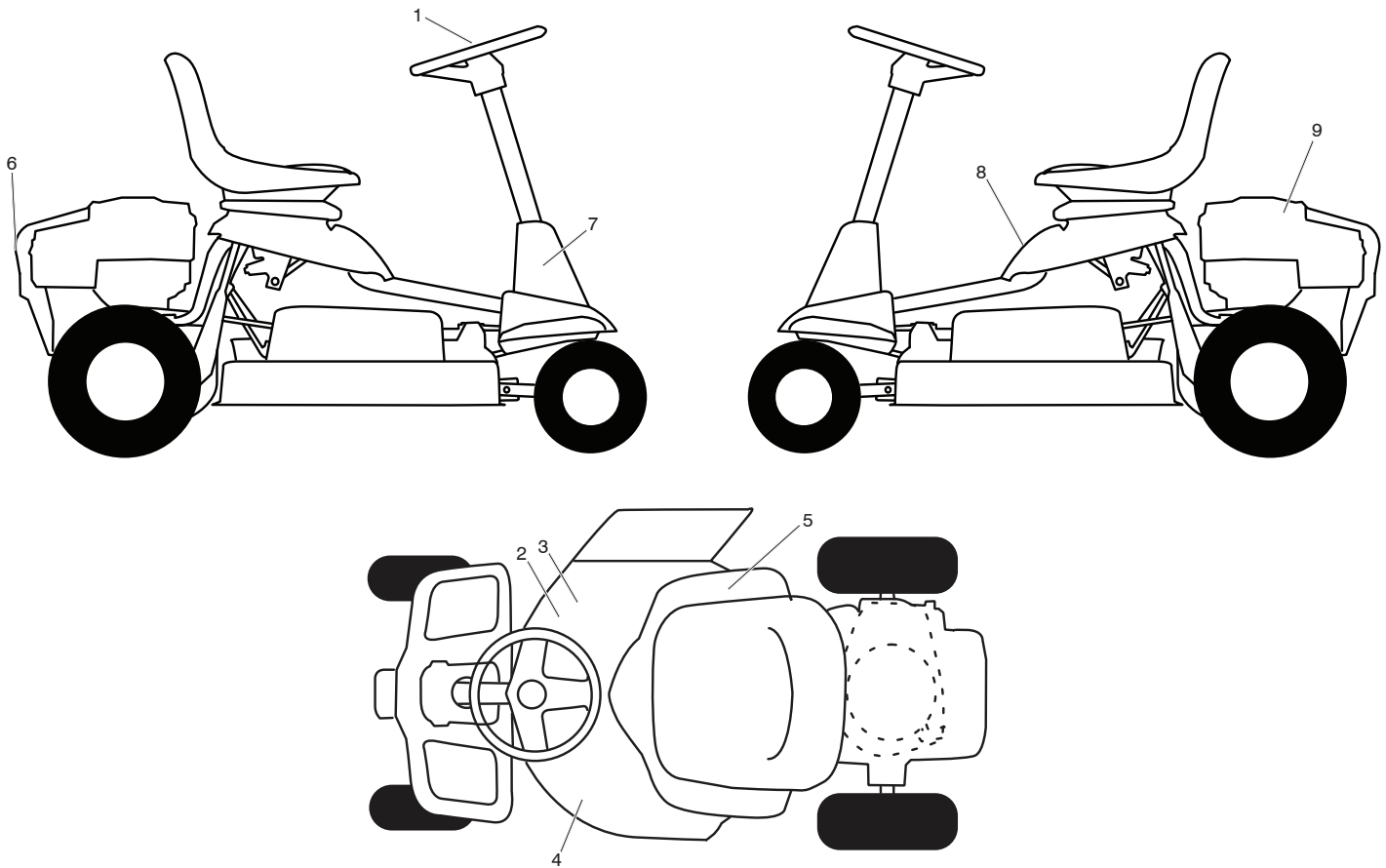

KEY NO.	PART NO.	DESCRIPTION
1	532 43 79-66	DECAL, STEERING WHEEL
2	532 43 35-96	DECAL, V-BELT SCH 26"
3	532 42 51-13	DECAL, WARN. DEFLECT/CTFGR
4	532 43 67-23	DECAL, DECK/DEFLECTOR LOGO
5	532 43 67-56	DECAL, WARNING CLUTCH
6	532 43 73-11	DECAL, WARNING
7	532 43 73-12	DECAL, STEERING BRKT
8	532 19 97-32	DECAL, NOISE LEVEL
9	532 44 10-94	DECAL, ENG. B&S
--	532 43 24-79	DECAL, BYPASS
--	532 44 18-15	MANUAL OPERS LRV ENGLISH

NOTE: All component dimensions given in U.S. inches
1 inch = 25.4 mm

RIDING MOWER - - MODEL NO. 960210014 (96021001401), PRODUCT NO. 960 21 00-14 SCHEMATIC **38**

SCH21

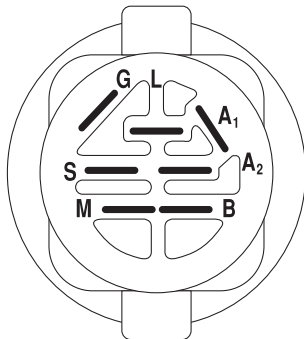
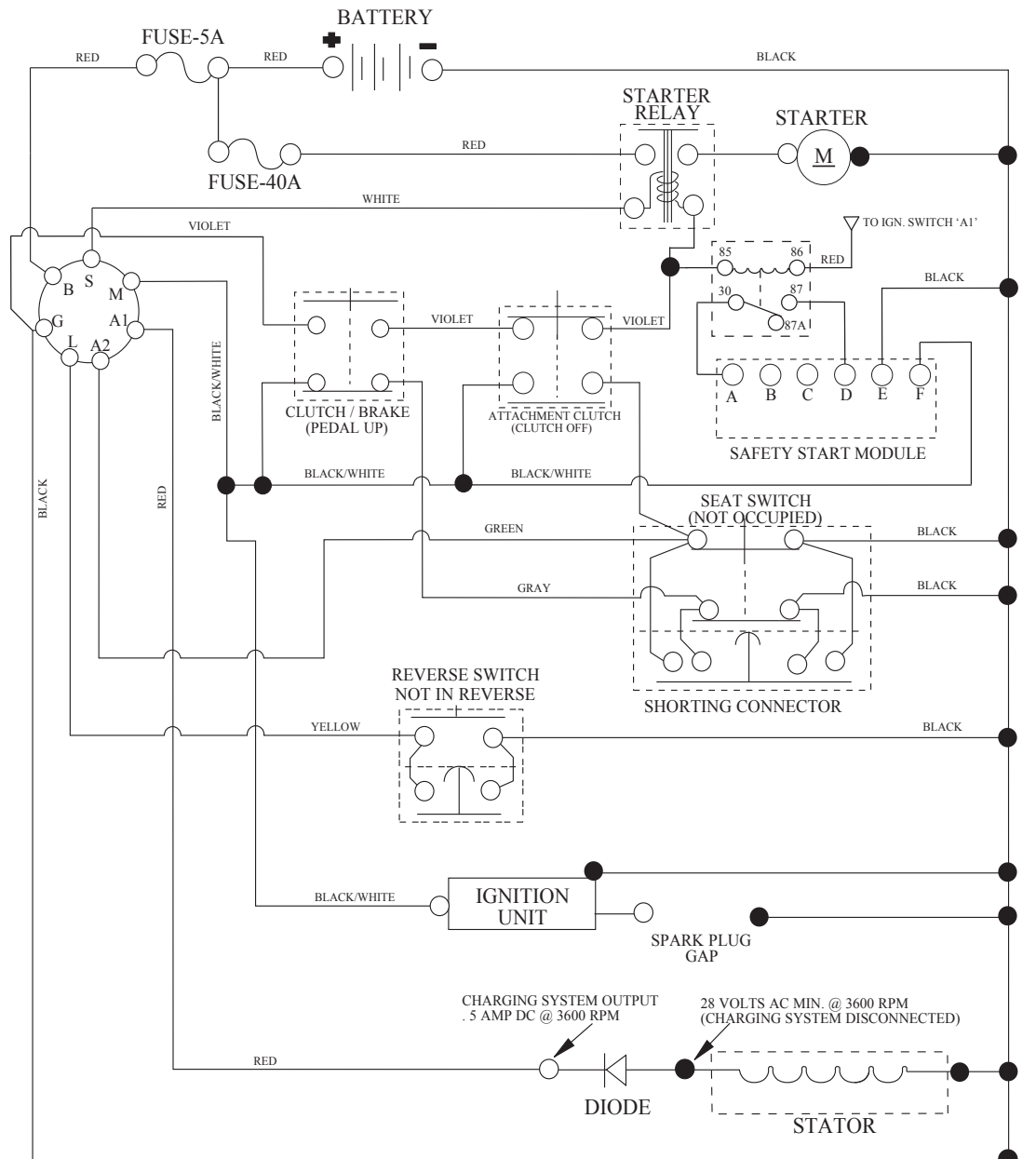

IGNITION SWITCH

POSITION	CIRCUIT "MAKE"
OFF	M+G+A1
RUN/OVERRIDE	B+A1
RUN	B+A1 L+A2
START	B + S + A1

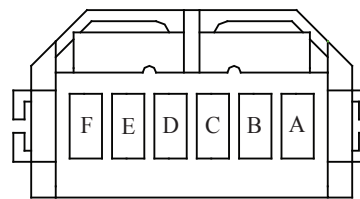

SAFETY START MODULE
VIEWED FROM MATING SIDE



WIRING INSULATED CLIPS
NOTE: IF WIRING INSULATED CLIPS
WERE REMOVED FOR SERVICING OF
UNIT, THEY SHOULD BE RE-INSTALLED
TO PROPERLY SECURE YOUR WIRING.

LRV1

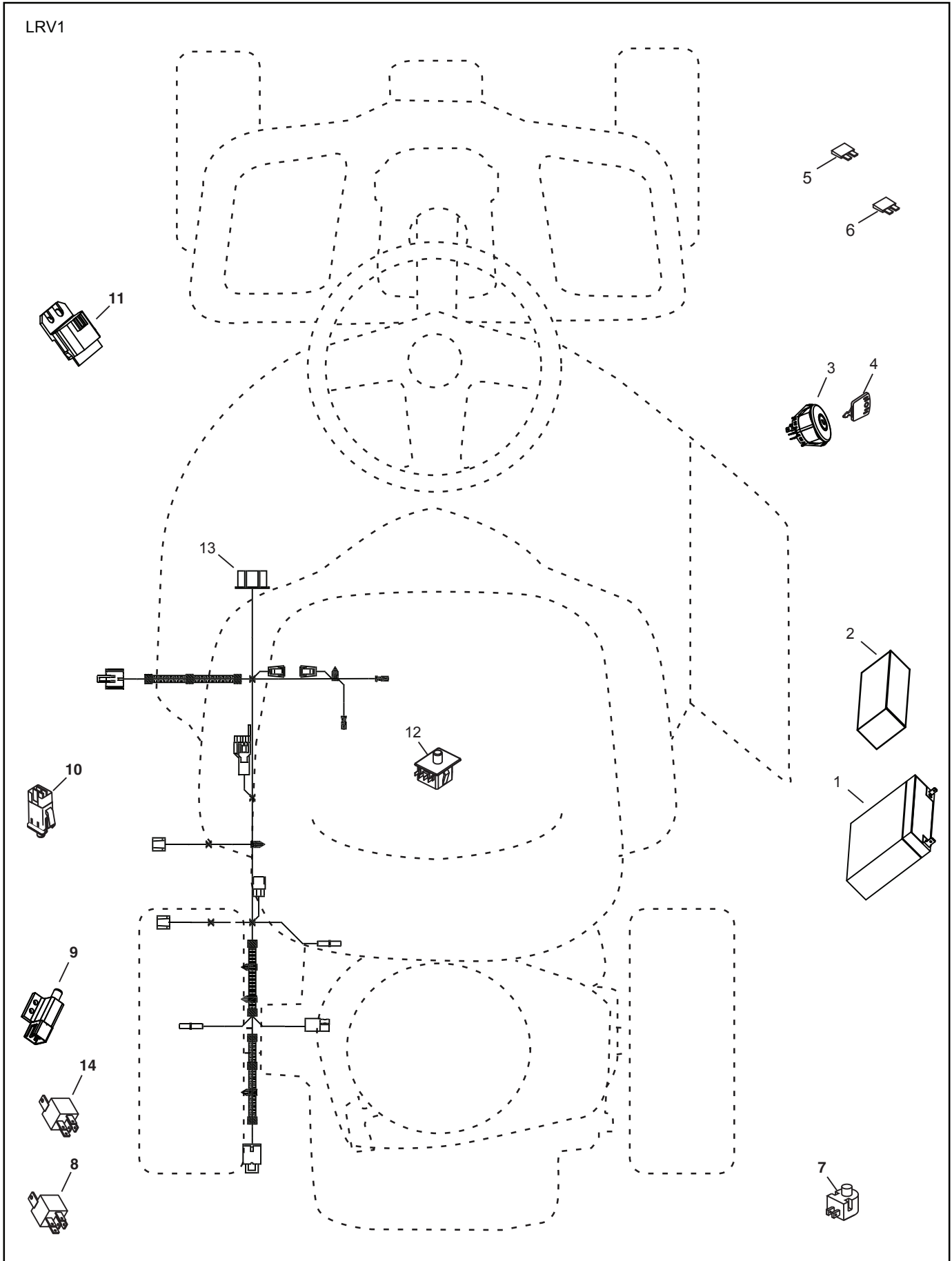

**RIDING MOWER - - MODEL NO. 960210014 (96021001401), PRODUCT NO. 960 21 00-14
ELECTRICAL 32**

KEY NO.	PART NO.	DESCRIPTION
1	532 43 70-70	BATTERY
2	532 42 54-16	FOAM, POLYURETHANE
3	532 19 33-50	SWITCH, IGN, DLTA, P-IN, ROS
4	532 41 19-35	KEY, MOLDED
5	532 43 33-30	FUSE, 5A
6	532 42 59-37	FUSE, 40A
7	532 16 07-84	SWITCH, PLUNGER, NO, OLIVE
8	532 43 15-42	RELAY, 40A
9	532 10 95-53	SWITCH, INTLK,CL, MWR, GRY
10	532 17 61-38	SWITCH, INTERLOCK, NONC,GRAY
11	532 43 18-46	MODULE, STARTING, RECOIL, LRV
12	532 19 27-49	SWITCH, SEAT, DP, ROS
13	532 44 22-41	HARNESS, LRV, ELECT START
14	532 10 97-48	RELAY

NOTE: All component dimensions given in U.S. inches
1 inch = 25.4 mm

RIDING MOWER - - MODEL NO. 960210014 (96021001401), PRODUCT NO. 960 21 00-14
CHASSIS AND ENCLOSURES **39**

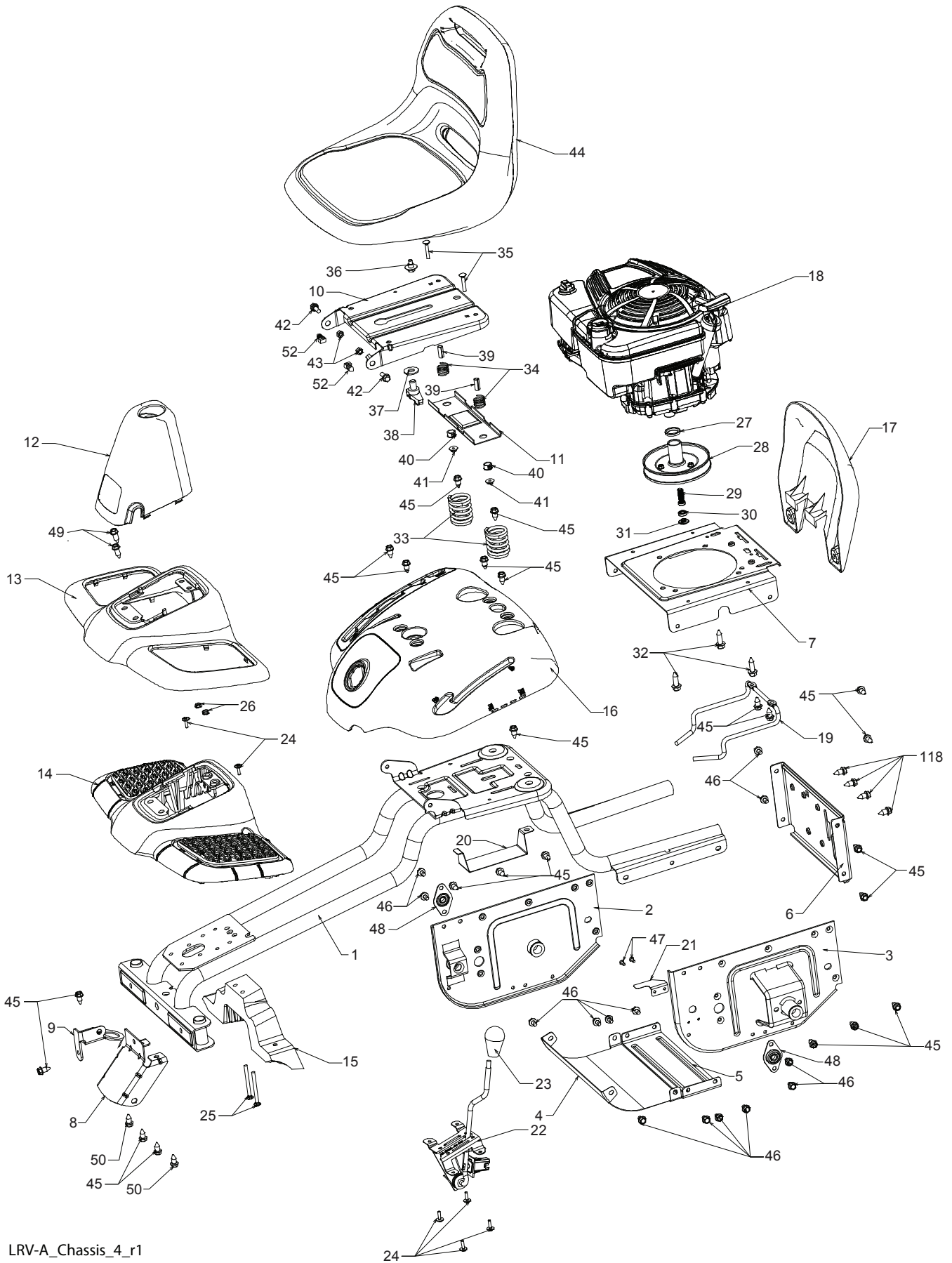

LRV-A_Chassis_4_r1

**RIDING MOWER - - MODEL NO. 960210014 (96021001401), PRODUCT NO. 960 21 00-14
CHASSIS AND ENCLOSURES **39****

KEY NO.	PART NO.	DESCRIPTION
1	532 42 80-48	WELDMENT, CHASSIS
2	532 42 82-47	SUPPORT, AXEL LH
3	532 42 82-44	SUPPORT, AXEL RH
4	532 42 83-46	SHIELD, TRANSAXLE FRONT
5	532 42 81-10	BRACE, AXLE CROSS
6	532 43 39-68	COVER, FRICTION DRIVE
7	532 42 80-40	PLATE, ENGINE
8	532 42 85-76	BRACKET, CHASSIS FRONT
9	532 42 88-56	BRACKET, STEERING SUPPORT
10	532 19 55-30	PAN, SEAT
11	532 17 46-48	BRACKET, SWITCH MOUNTING
12	532 43 67-53	BOOT, DUST
13	532 43 69-13	COVER, FOOT REST
14	532 42 82-50	STRUCTURE, FOOT REST
15	532 42 82-49	SUPPORT, FOOT REST
16	532 43 69-11	FENDER, CONTROL
17	532 42 83-48	GUARD, ENGINE
18	--- -- ---	ENGINE, 14B907-1552-B1 (440972) (Order parts from engine manufacturer)
19	532 42 89-86	KEEPER, BELT
20	532 42 80-46	BRACKET, BATTERY
21	532 42 98-15	LEVER, SWITCH
22	532 42 88-26	DECK CLUTCH ASM
23	532 14 98-46	KNOB
24	532 41 63-58	SCREW, NO. 10
25	872 14 04-24	BOLT, CARRIAGE 1/4-20 X 3
26	873 51 04-00	NUT, 1/4-20
27	532 43 00-87	SPACER, ENGINE
28	532 42 83-01	DISC, FRICTION ASM
29	532 43 08-17	BOLT, SCKT HD 3/8-24 X 1 .25
30	532 43 04-70	BEARING
31	532 43 73-22	SPACER, NEUTRAL
32	532 15 04-06	BOLT, 3/8-16 X .280
33	532 12 41-81	SPRING, SEAT
34	532 12 12-50	SPRING
35	872 05 04-12	BOLT, 1/4-20 X 1 1/2
36	532 12 70-18	BOLT, SHOULDER
37	819 17 19-12	WASHER, 17/32 X 1 3/16
38	532 16 63-69	KNOB, SEAT
39	532 13 43-00	SPACER
40	532 12 12-48	BUSHING, NYLON SNAP
41	532 12 39-76	NUT, LOCK
42	532 17 18-52	BOLT, 5/16-18 SHOULDER
43	873 80 05-00	NUT, 5/16-18
44	532 44 06-92	SEAT
45	817 00 05-12	BOLT, 5/16-18 X 3/4
46	817 49 05-08	BOLT, 5/16-18 X 1/2
47	532 08 67-77	SCREW,
48	532 40 89-81	BEARING, FLANGE, BALL
49	817 06 05-16	SCREW, 5/16-18 X1
50	532 16 54-92	BOLT, SHOULDER, 5/16-18 X .561
52	532 14 50-06	CLIP PUSH-IN HINGED
118	532 17 01-65	BOLT SHOULDER 5/16-18

NOTE: All component dimensions given in U.S. inches
1 inch = 25.4 mm

RIDING MOWER - - MODEL NO. 960210014 (96021001401), PRODUCT NO. 960 21 00-14
DRIVE **40**

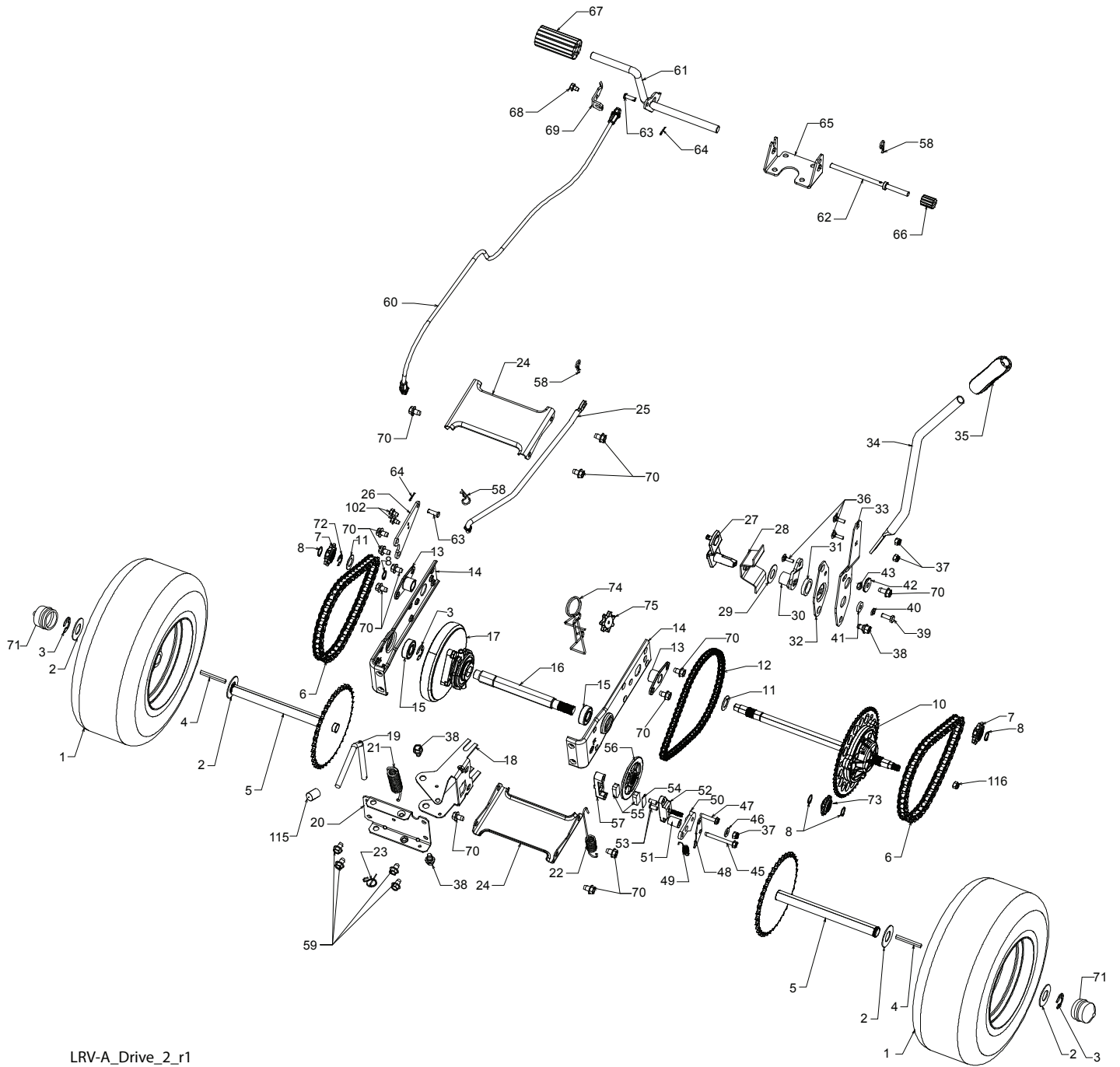

LRV-A_Drive_2_r1

**RIDING MOWER - - MODEL NO. 960210014 (96021001401), PRODUCT NO. 960 21 00-14
DRIVE **40****

KEY NO.	PART NO.	DESCRIPTION	KEY NO.	PART NO.	DESCRIPTION
--	532 43 61-44	SERVICE KIT, TRANSAXLE	41	819 09 12-10	WASHER FLAT
1	532 43 69-15	WHEEL ASM (REAR)	42	532 16 60-02	WASHER, SERRATED
2	532 12 17-48	WASHER, 16 GA.	43	873 68 04-00	NUT, CROWN LOCK 114-20
3	812 00 00-01	E-CLIP	45	817 49 04-36	SCREW 1/4-20 X 2 114
4	532 12 35-83	KEY, SQUARE	46	819 09 10-16	WASHER
5	532 42 79-39	WELDMENT. DRIVE AXLE	47	817 49 04-20	SCREW, 1/4-20 X 1 1/2
6	532 42 80-69	CHAIN DRIVE	48	532 43 02-49	PLATE BRAKE ANTI - ROTATE
7	532 42 78-73	SPROCKET. 9 TOOTH SPLINED	49	532 43 02-45	SPRING, BRAKE RETURN
8	812 10 00-09	RING, SNAP	50	532 42 80-21	ARM, BRAKE
10	532 42 88-76	DIFFERENTIAL ASM	51	532 43 02-47	SPACER RETURN
11	532 00 13-70	WASHER, THRUST	52	532 42 80-78	CALIPER, BRAKE ASM
12	532 43 06-45	CHAIN, PRIMARY DRIVE	53	877 01 08-10	PIN, DOWEL 1/4
13	532 43 08-45	BUSHING	54	532 42 80-19	PLATE, BRAKE PAD
14	532 43 85-68	BRACKET, CARRIER	55	532 42 80-17	PUCK BRAKE
15	532 12 47-93	BEARING ASM	56	532 43 52-53	ROTOR, BRAKE
16	532 42 79-26	SHAFT INPUT	57	532 42 80-16	CAP, BRAKE CALIPER
17	532 43 72-81	WHEEL, FRICTION A5M	58	532 12 47-88	PIN, RETAINER
18	532 42 47-59	ARM, SHIFT	59	817 49 05-08	BOLT, 5/16-16 X 112
19	532 43 08-70	ROD, BYPASS	60	532 44 08-55	CABLE, BRAKE
20	532 42 79-97	BRACE CARRIER REAR	61	532 42 79-45	WELDMENT, PEDAL
21	532 42 80-77	SPRING, CARRIER	62	532 42 96-78	ROD, PARKING BRAKE
22	532 42 80-76	SPRING, BRAKE	63	877 10 08-12	PIN, .25 X .75 CLEVIS
23	532 43 13-74	SPRING, BYPASS	64	532 42 10-76	PIN, COTTER 5/64 X 3/4
24	532 42 79-95	BRACE CARRIER BOX	65	532 42 93-25	BRACKET, BRAKE SUPPORT
25	532 42 83-03	LINK, SHIFT	66	532 42 96-94	COVER PEDAL
26	532 42 98-16	ARM. CLUTCH	67	532 42 96-93	COVER, BRAKE PEDAL
27	532 42 90-53	WELDMENT SHIFT LEVER	68	817 49 04-06	SCREW, 1/4-20 X 3/8
28	532 42 83-02	SUPPORT, SHIFT LEVER	69	532 42 80-70	BRAKE CABLE MOUNT
29	532 17 48-40	WASHER, NYLON	70	817 00 05-12	BOLT, 5/16-18 X 3/4
30	532 18 39-00	HUB SHIFT LEVER	71	532 19 32-68	CAP HUB AXLE
31	532 42 90-55	SPACER, NYLON	72	812 00 00-02	E RING #5133-62
32	532 42 84-64	MNTG BRKT. SHIFT ARM	73	532 42 95-19	SPROCKET II TOOTH SPLINED
33	532 42 84-61	BRACKET, SHIFTER FLEX	74	532 43 78-41	TENSION LRV CHAIN
34	532 42 84-62	TUBE SHIFT ARM	75	532 43 34-95	SPROCKET, IDLER
35	532 41 15-55	GRIP, HANDLE	102	532 08 67-77	SCREW THREAD CUTTER
36	872 11 04-06	BOLT, CARRIAGE - 114-20 X 3/4	115	532 14 00-62	CAP PLUNGER
37	873 80 04-00	NUT NYLON LOCK 114-20	116	873 90 06-00	NUT LOCK 3/8-16 UNC
38	532 16 54-92	BOLT, SHOULDER			
39	874 78 04-12	BOLT, 1/4-20 X 3/4			
40	810 04 04-00	WASHER, LOCK			

NOTE: All component dimensions given in U.S. inches
1 inch = 25.4 mm

RIDING MOWER - - MODEL NO. 960210014 (96021001401), PRODUCT NO. 960 21 00-14
STEERING ASSEMBLY **41**

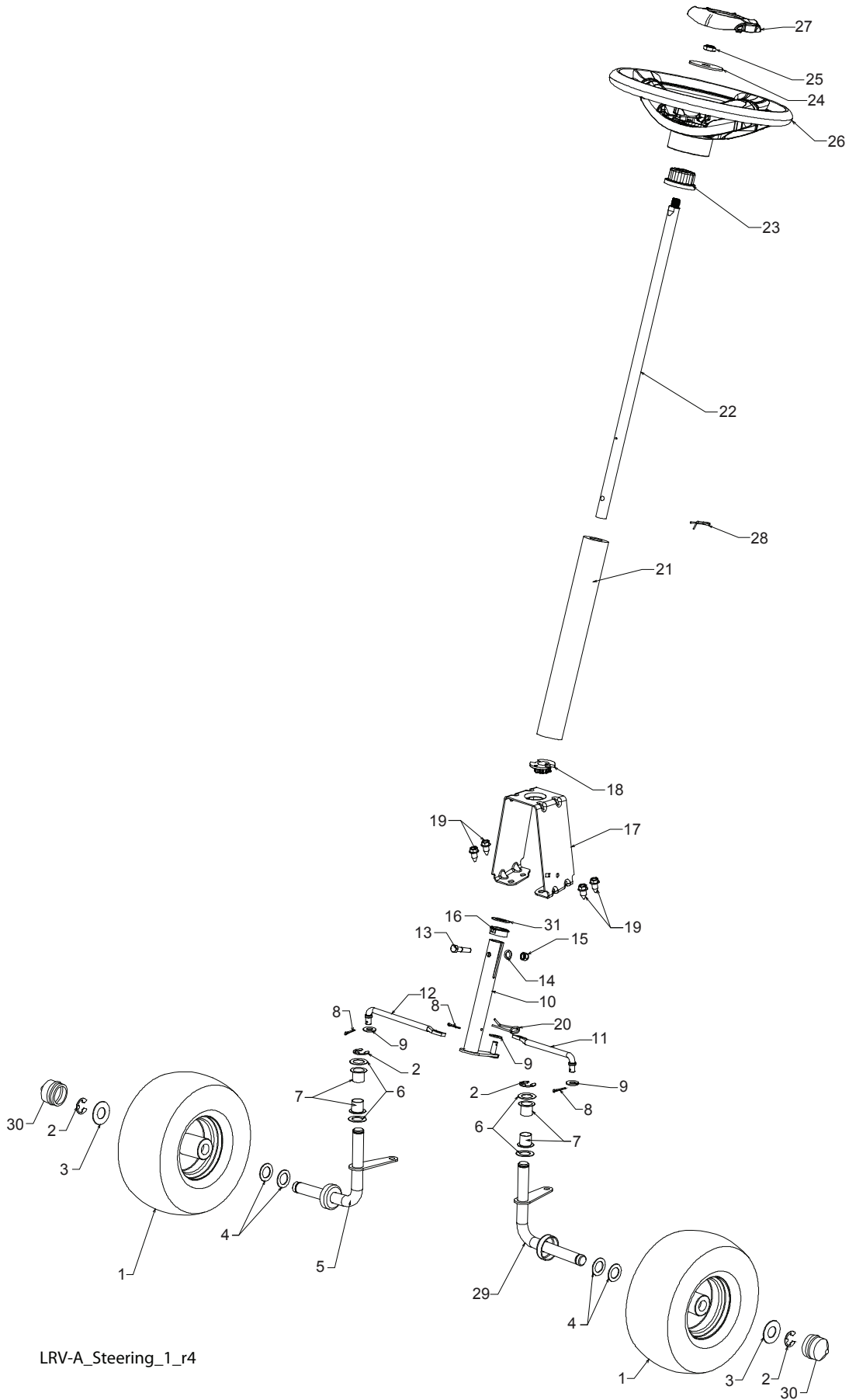

LRV-A_Steering_1_r4

**RIDING MOWER - - MODEL NO. 960210014 (96021001401), PRODUCT NO. 960 21 00-14
STEERING ASSEMBLY **41****

KEY NO.	PART NO.	DESCRIPTION
1	532 43 69-46	WHEEL ASM (FRONT)
2	812 00 00-01	E-CLIP
3	532 18 89-67	WASHER, HARDENED
4	532 12 17-49	WASHER, 1/4 X 3/4
5	532 43 53-24	SPINDLE, RH
6	532 12 49-31	WASHER, HARDENED THRUST
7	532 12 49-37	BUSHING, STEERING COLUMN
8	532 42 10-76	PIN, 5/64 X 3/4 COTTER
9	819 13 14-14	WASHER
10	532 42 80-57	WELDMENT, LWR STRG SHAFT
11	532 42 80-35	LINK, STRNG LH
12	532 42 80-36	LINK, STRNG RH
13	874 78 05-24	BOLT, 5/16-18 X 1 1/2
14	819 13 10-16	WASHER
15	873 80 05-00	NUT, 5/16-18
16	532 42 80-44	BUSHING, STEERING SNAP
17	532 42 82-52	SUPPORT, UPPER STEERING
18	532 19 52-27	BUSHING, UPPER STEERING
19	817 00 05-12	BOLT, 5/16-18 X 3/4
20	532 42 80-45	CLIP, RETAINER SPRING
21	532 42 83-47	COVER, STEERING COLUMN
22	532 42 82-13	SHAFT, STEERING
23	532 43 77-47	ADAPTER, STEERING WHEEL
24	819 18 38-12	WASHER, 9/16 X 2 3/8 12 GA.
25	873 94 08-00	NUT, JAM LOCK 1/2-20
26	532 42 45-51	WHEEL, STEERING
27	532 44 15-06	CAP, STEERING WHEEL
28	532 19 98-49	CLIP, RETAINER SPRING
29	532 43 53-23	SPINDLE, LH
30	532 19 32-68	CAP, HUB, AXLE
31	819 34 32-10	WASHER 1 1/16 X 2 X 10 GA.

NOTE: All component dimensions given in U.S. inches
1 inch = 25.4 mm

**RIDING MOWER - - MODEL NO. 960210014 (96021001401), PRODUCT NO. 960 21 00-14
MOWER DECK 44**

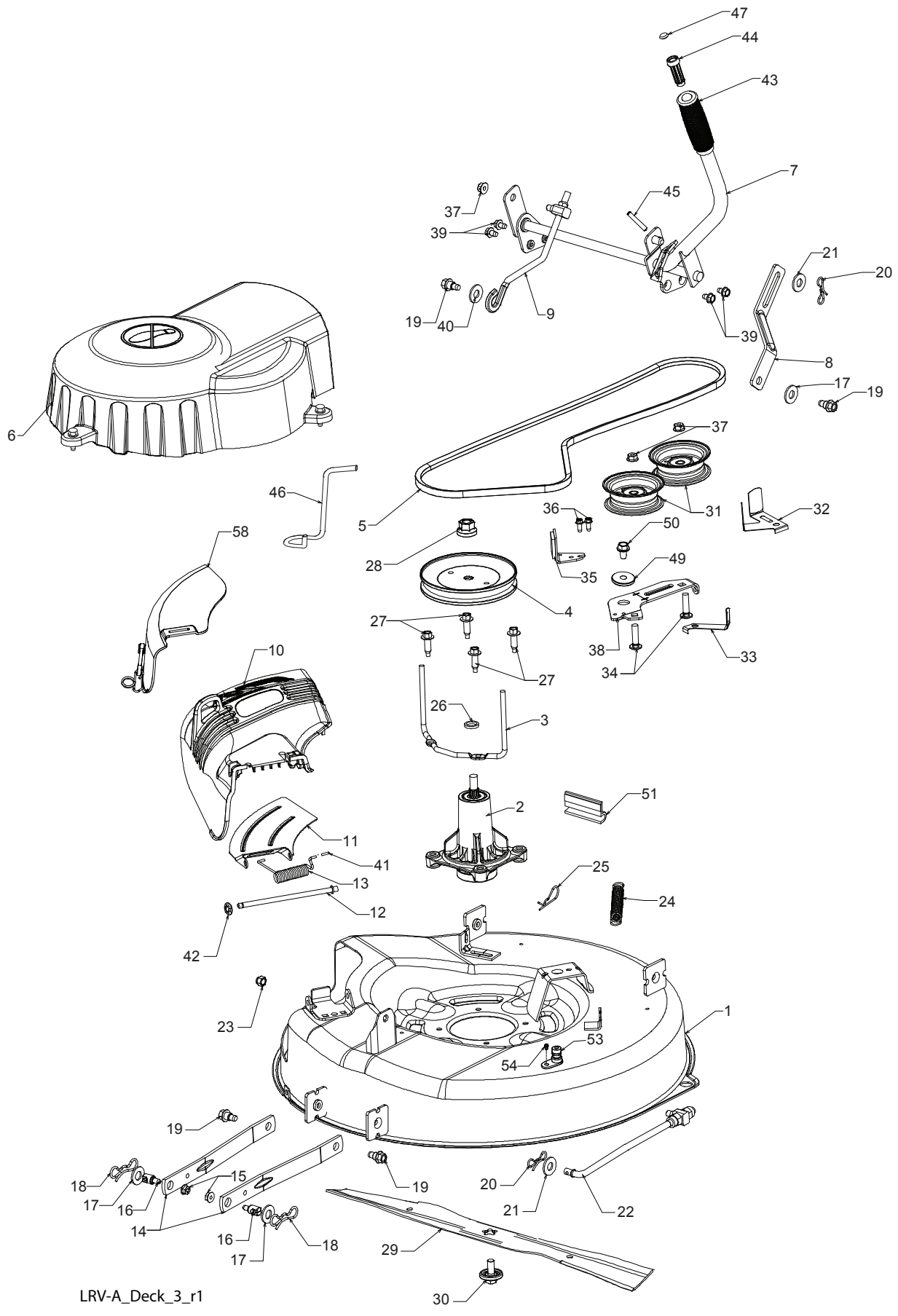

LRV-A_Deck_3_r1

**RIDING MOWER - - MODEL NO. 960210014 (96021001401), PRODUCT NO. 960 21 00-14
MOWER DECK 44**

KEY NO.	PART NO.	DESCRIPTION
1	532 42 81-93	DECK, 26"
2	532 19 28-70	MANDREL ASM
3	532 43 25-20	KEEPER, BELT
4	532 43 25-94	PULLEY, MANDREL
5	532 42 85-78	BELT
6	532 43 93-76	COVER, MANDREL
7	532 42 93-95	LIFT ASM, DECK
8	532 42 91-95	LINK, DECK LIFT
9	532 42 93-97	LINK, ADJUSTABLE
10	532 43 89-23	DEFLECTOR
11	532 42 89-68	SUPPORT, DEFLECTOR
12	532 13 14-91	ROD, HINGE
13	532 19 70-26	SPRING, TORSION
14	532 41 88-63	ARM, MOWER SUPPORT
15	873 90 05-00	NUT, LOCK
16	532 19 51-61	STUD
17	819 19 19-12	WASHER
18	532 19 42-09	PIN
19	532 19 65-39	BOLT, SHOULDER
20	532 19 42-08	PIN
21	819 17 19-12	WASHER, 17/32 X 1 3/16
22	532 42 93-50	LINK, DECK
23	873 90 06-00	NUT, LCK 3/8-16
24	532 42 95-31	SPRING, DECK
25	532 12 47-88	PIN
26	532 18 76-90	SPACER, MANDREL
27	532 17 39-84	BOLT, MANDREL
28	532 40 02-34	NUT, LOCK
29	532 43 90-52	BLADE
30	532 19 30-03	BOLT, BLADE
31	532 19 31-97	PULLEY, IDLER
32	532 14 10-43	GUARD, IDLER
33	532 19 34-14	KEEPER, BELT IDLER
34	872 11 06-12	BOLT, 3/8-16 X 1 1/2
35	532 19 94-70	ARM, BRAKE
36	532 13 77-29	SCREW, 1/4-20 X 5/8
37	873 90 06-00	NUT, 3/8-16 FLANGE
38	532 42 84-35	ARM, IDLER
39	817 49 05-08	BOLT, 5/16-18 X 1/2
40	819 17 16-16	WASHER, 16 GA.
41	532 10 53-04	CAP, SLEEVE
42	532 11 04-52	NUT, PUSH
43	532 12 56-31	GRIP, HANDLE
44	532 42 94-01	PLUNGER
45	532 10 57-67	PIN
46	532 43 86-10	KEEPER, BELT
47	532 12 45-26	BUTTON PLUNGER
49	532 19 90-92	SPACER RETAINER
50	817 00 06-16	SCREW 3/8-16 X 1
51	532 40 47-42	BUMPER
53	532 41 55-98	PORT WASHOUT
54	532 15 29-27	SCREW #10-32.5.3/8 FLANGE
58	532 42 97-58	COVER ASM MULCH

NOTE: All component dimensions given in U.S. inches
1 inch = 25.4 mm

