



# MCCULLOCH



# MC621

---

**Illustrated Parts List**

# REPAIR PARTS SNOW THROWER - - MODEL NUMBER MC621 (96188000300)

## CHUTE ASSEMBLY

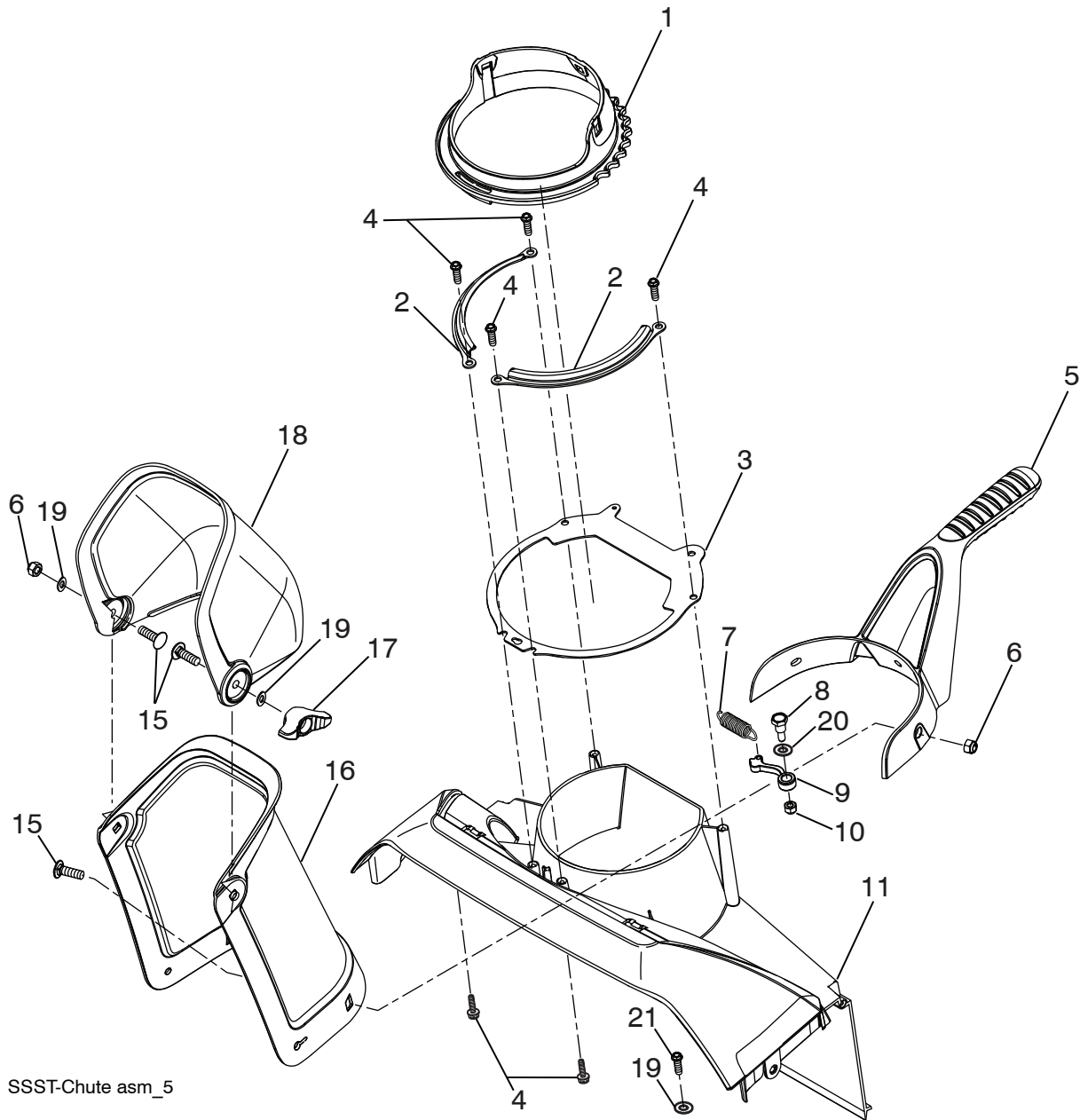

**NOTE:** All component dimensions given in U.S. inches. 1 inch = 25.4 mm  
**IMPORTANT:** Use only Original Equipment Manufacturer (O.E.M.) replacement parts.  
Failure to do so could be hazardous, damage your snow thrower and void your warranty.

**REPAIR PARTS SNOW THROWER - - MODEL NUMBER MC621 (96188000300)  
CHUTE ASSEMBLY**

KEY NO.	PART NO.	QTY	DESCRIPTION
1	532 43 48-77	1	CHUTE.RATCHETING.PLASTIC.W/GRV
2	532 43 76-40	2	PLATE.CHUTE.RETAINER
3	532 43 76-35	1	PLATE.CHUTE.BASE
4	817 41 13-12	6	BOLT.HEX.WSH.HD.13-16 X 3/4
5	532 43 76-42	1	HANDLE.CHUTE.MS428
6	873 97 05-00	4	NUT.LOCK.HX.W/INS 5/16-18 UNC PL
7	532 43 48-79	1	SPRING.RATCHET.ARM
8	532 08 13-28	1	BOLT.SHOULDER.1/4-20 UNC X .94
9	532 43 48-78	1	ARM.CHUTE.RATCHET
10	532 13 20-04	1	HEX.NUT.1/4-20 NYLON LOCKING
11	532 43 76-26	1	PLENUM
15	532 43 73-18	5	CARRIAGE.BOLT
16	532 43 76-55	1	CHUTE
17	532 19 19-38	1	HANDLE.KNOB
18	532 43 76-43	1	DEFLECTOR.CHUTE
19	819 13 13-16	3	WASHER
20	819 13 20-16	1	WASHER.RATCHET.PAWL
21	532 42 88-67	1	BOLT

**NOTE:** All component dimensions given in U.S. inches. 1 inch = 25.4 mm  
**IMPORTANT:** Use only Original Equipment Manufacturer (O.E.M.) replacement parts.  
 Failure to do so could be hazardous, damage your snow thrower and void your warranty.

**REPAIR PARTS SNOW THROWER - - MODEL NUMBER MC621 (96188000300)**  
**HANDLE ASSEMBLY**

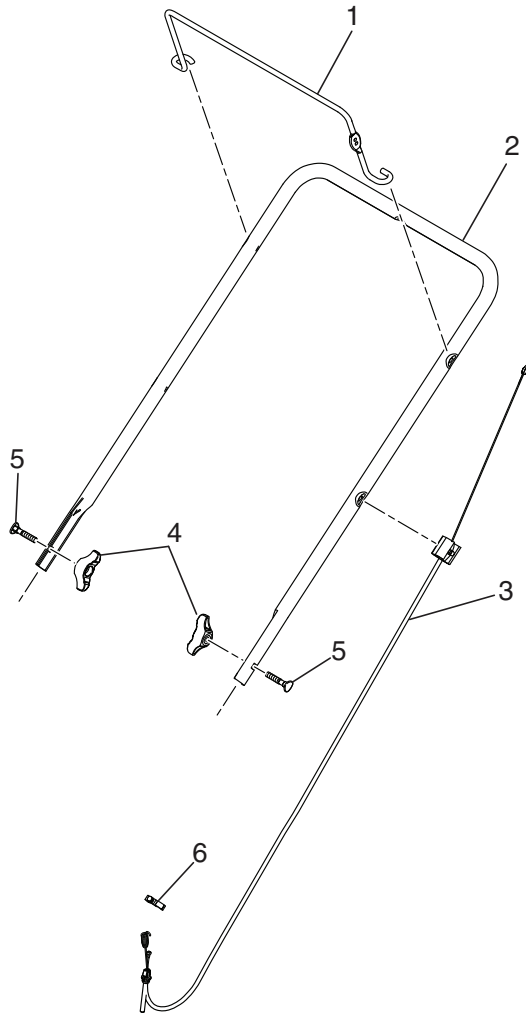

SSST-Handle asm\_1

KEY NO.	PART NO.	QTY	DESCRIPTION
1	532 43 76-67	1	BAIL.HANDLE.PAINT.MS431
2	532 43 76-64	1	HANDLE.PNT.UPPER.SSST
3	532 43 48-06	1	CONTROL.CABLE
4	532 19 19-38	2	KNOB.HANDLE.BLACK
5	532 19 15-74	2	BOLT.HANDLE.BLACK PATCHED
6	532 14 50-06	1	CLIP.PUSH-IN.HINGED

**NOTE:** All component dimensions given in U.S. inches. 1 inch = 25.4 mm  
**IMPORTANT:** Use only Original Equipment Manufacturer (O.E.M.) replacement parts.  
 Failure to do so could be hazardous, damage your snow thrower and void your warranty.

# REPAIR PARTS SNOW THROWER - - MODEL NUMBER MC621 (96188000300)

## AUGER ASSEMBLY

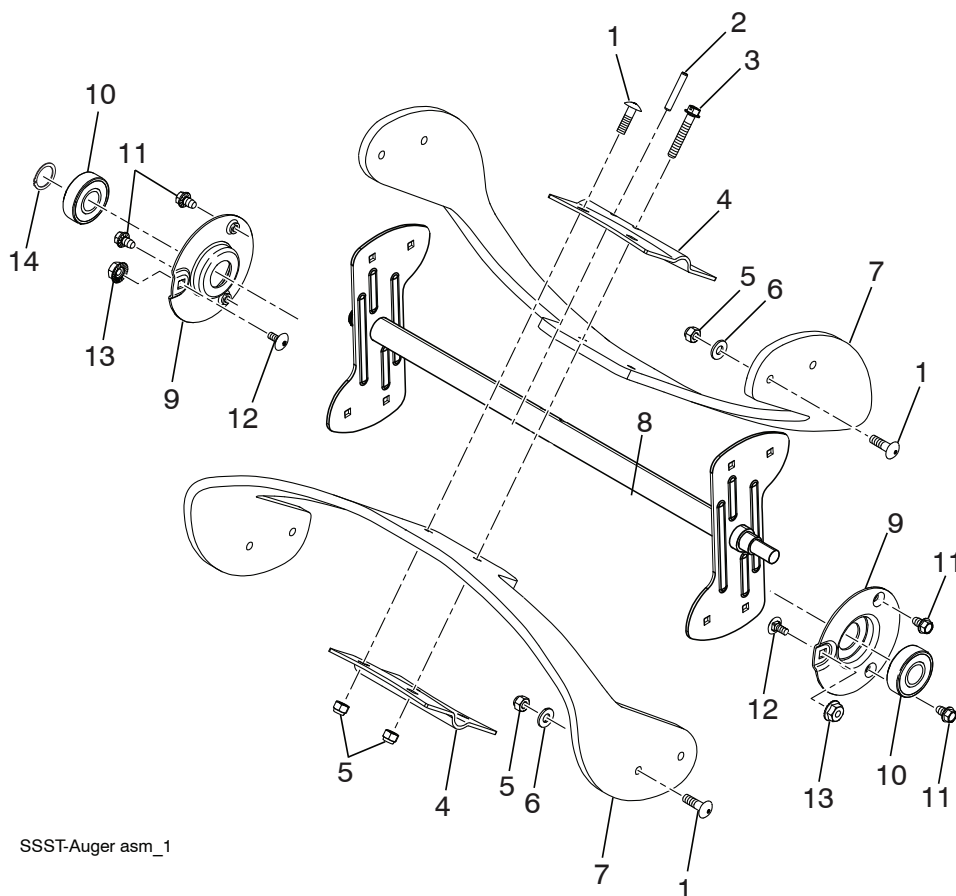

SSST-Auger asm\_1

KEY NO.	PART NO.	QTY	DESCRIPTION
1	872 11 04-07	12	BOLT.CARRIAGE
2	532 43 76-20	1	PIN.ROLL.3/16 X 1-1/4
3	532 19 96-87	1	BOLT.1/4-20.1.50"
4	532 43 76-18	2	PLATE.CENTER.BLADE
5	532 13 20-04	13	HEX.NUT.1/4-20 NYLON LOCKING
6	819 09 10-16	8	WASHER 9/32 X 5/8 X 16 GA.
7	532 43 74-59	2	BLADE.AUGER
8	532 43 76-17	1	WELDMENT.AUGER.ASM
9	532 43 76-21	2	SUPPORT.BEARING.SSST.PNT
10	532 43 76-22	2	BEARING.BALL.MANDREL
11	817 60 04-06	4	SCREW.HEX.WASHEAD.1/4-20 X 3/8
12	872 11 04-04	2	BOLT.CARR.SS.1/4-20 UNC X 1/2.GR5
13	873 68 04-00	2	WHIZ.LOCK.NUTS.BEARING CAPS
14	812 00 00-28	1	RETAINING.CLIP

**NOTE:** All component dimensions given in U.S. inches. 1 inch = 25.4 mm  
**IMPORTANT:** Use only Original Equipment Manufacturer (O.E.M.) replacement parts. Failure to do so could be hazardous, damage your snow thrower and void your warranty.

# REPAIR PARTS SNOW THROWER - - MODEL NUMBER MC621 (96188000300) SHROUD ASSEMBLY

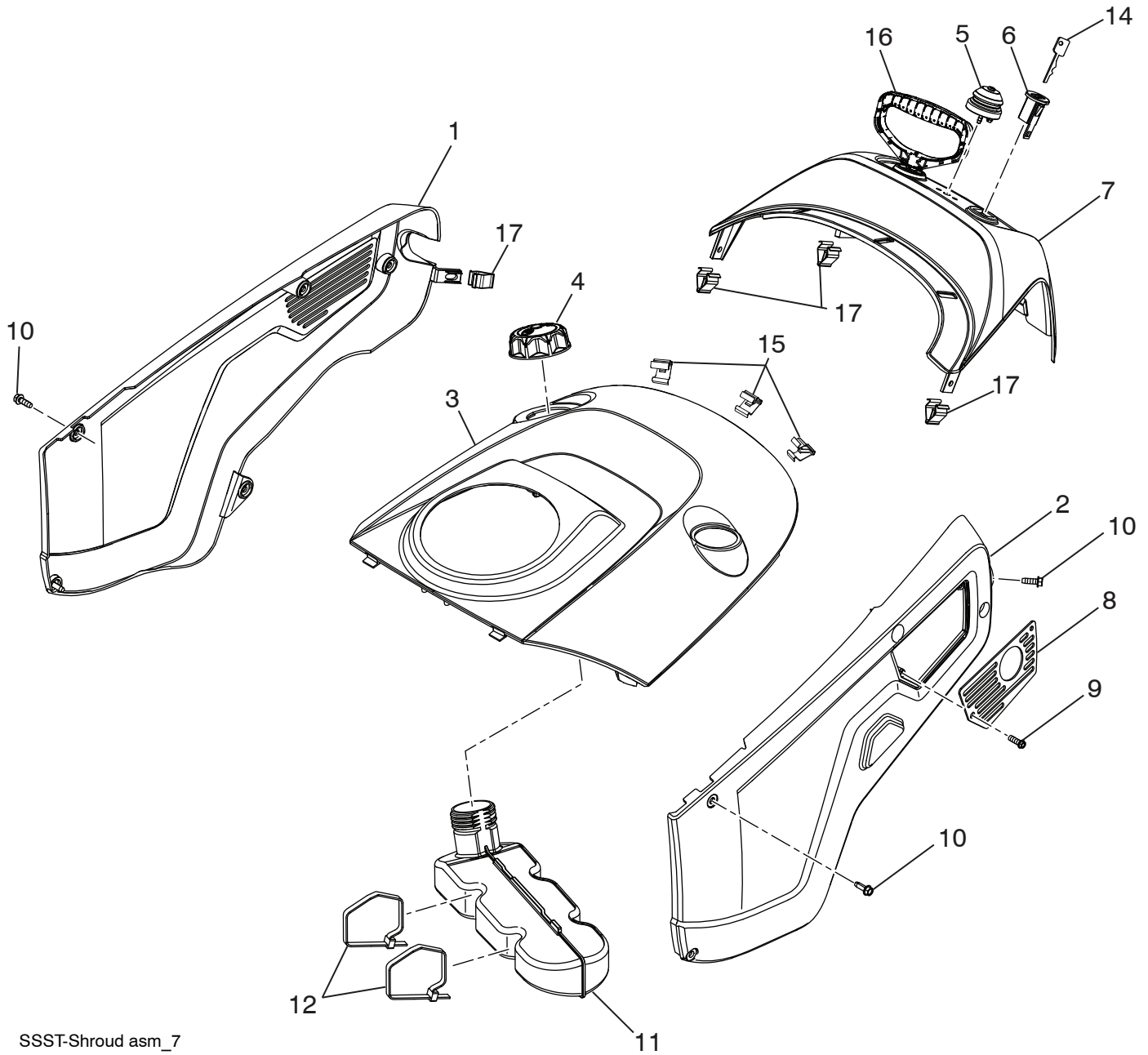

SSST-Shroud asm\_7

**NOTE:** All component dimensions given in U.S. inches. 1 inch = 25.4 mm  
**IMPORTANT:** Use only Original Equipment Manufacturer (O.E.M.) replacement parts.  
Failure to do so could be hazardous, damage your snow thrower and void your warranty.

**REPAIR PARTS SNOW THROWER - - MODEL NUMBER MC621 (96188000300)  
SHROUD ASSEMBLY**

KEY NO.	PART NO.	QTY	DESCRIPTION
1	532 43 76-27	1	COVER.NON-DRIVE.SIDE.MS428
2	532 43 76-30	1	COVER.DRIVE.SIDE.MS428
3	532 43 76-34	1	TOP.COVER
4	532 43 02-20	1	CAP.ASM.FUEL.2.25"FR.N/CB.E10
5	532 43 62-35	1	BULB.PRIMER
6	532 43 54-07	1	KEY HOUSING
7	532 43 76-48	1	TOP.REAR.COVER
8	532 43 76-31	1	PLATE.EXHAUST.PNT.
9	817 41 13-12	2	SCREW
10	817 67 04-12	12	SCREW.HEXWSH.THDROL.1/4-20X3/4
11	532 43 48-80	1	TANK.FUEL.ASM
12	532 14 68-48	2	TIE.CABLE.24.5X.29.NYLON.WHITE
14	532 43 54-09	2	KEY
15	532 43 48-68	3	CLIP
16	532 43 62-76	1	HANDLE.STARTER
17	532 19 66-88	4	CLIPS

**NOTE:** All component dimensions given in U.S. inches. 1 inch = 25.4 mm  
**IMPORTANT:** Use only Original Equipment Manufacturer (O.E.M.) replacement parts.  
 Failure to do so could be hazardous, damage your snow thrower and void your warranty.

# REPAIR PARTS SNOW THROWER - - MODEL NUMBER MC621 (96188000300) FRAME ASSEMBLY

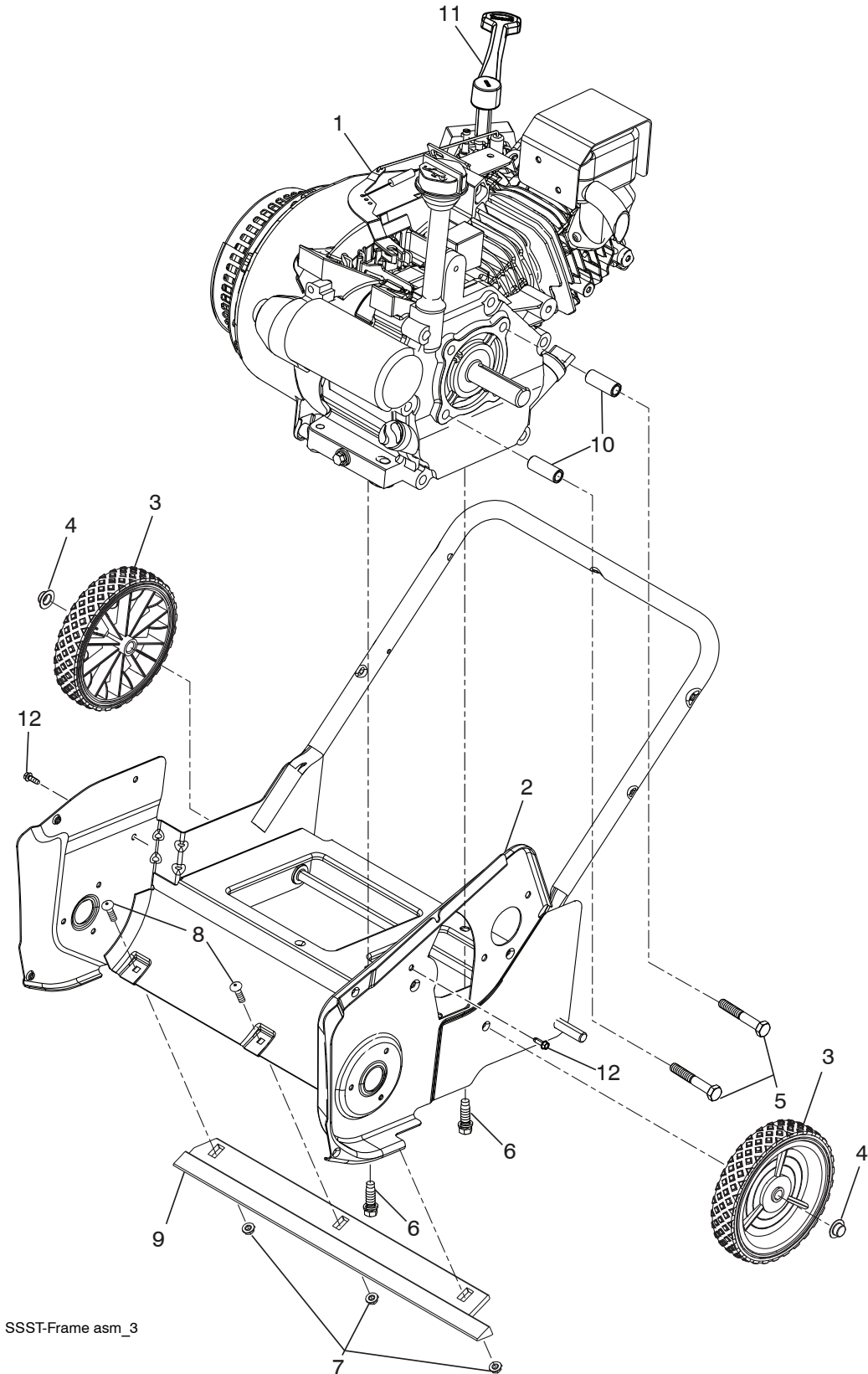

SSST-Frame asm\_3

**NOTE:** All component dimensions given in U.S. inches. 1 inch = 25.4 mm  
**IMPORTANT:** Use only Original Equipment Manufacturer (O.E.M.) replacement parts.  
Failure to do so could be hazardous, damage your snow thrower and void your warranty.



**REPAIR PARTS SNOW THROWER - - MODEL NUMBER MC621 (96188000300)  
FRAME ASSEMBLY**

KEY NO.	PART NO.	QTY	DESCRIPTION
1	532 43 48-56	1	LCT.ENGINE
2	532 43 76-06	1	FRAME.WELDMENT
3	532 43 76-62	2	WHEEL.8X1.5.BRICK.GS.3SPK.MS421
4	532 43 54-17	2	NUT.PUSH.AXLE.0.5IN
5	532 43 55-78	2	SCREW. 5/16-24 X 2.00"HHCS
6	532 15 04-06	2	BOLT.ENG. 3/8-16 X 1.280
7	532 19 17-30	3	NUT.HEX.FLANGE.1/4-20.CTR.LOCK
8	872 14 04-05	3	BOLT.RDHD.SQNK.1/4-20 UNC X 5/8
9	532 43 55-35	1	PLATE.SCRAPER
10	532 43 48-57	2	SPACER.ENGINE
11	532 43 48-74	1	LEVER.CHOKE
12	817 41 13-12	2	HEX.BOLT

**NOTE:** All component dimensions given in U.S. inches. 1 inch = 25.4 mm  
**IMPORTANT:** Use only Original Equipment Manufacturer (O.E.M.) replacement parts.  
 Failure to do so could be hazardous, damage your snow thrower and void your warranty.

# REPAIR PARTS SNOW THROWER - - MODEL NUMBER MC621 (96188000300)

## DRIVE ASSEMBLY

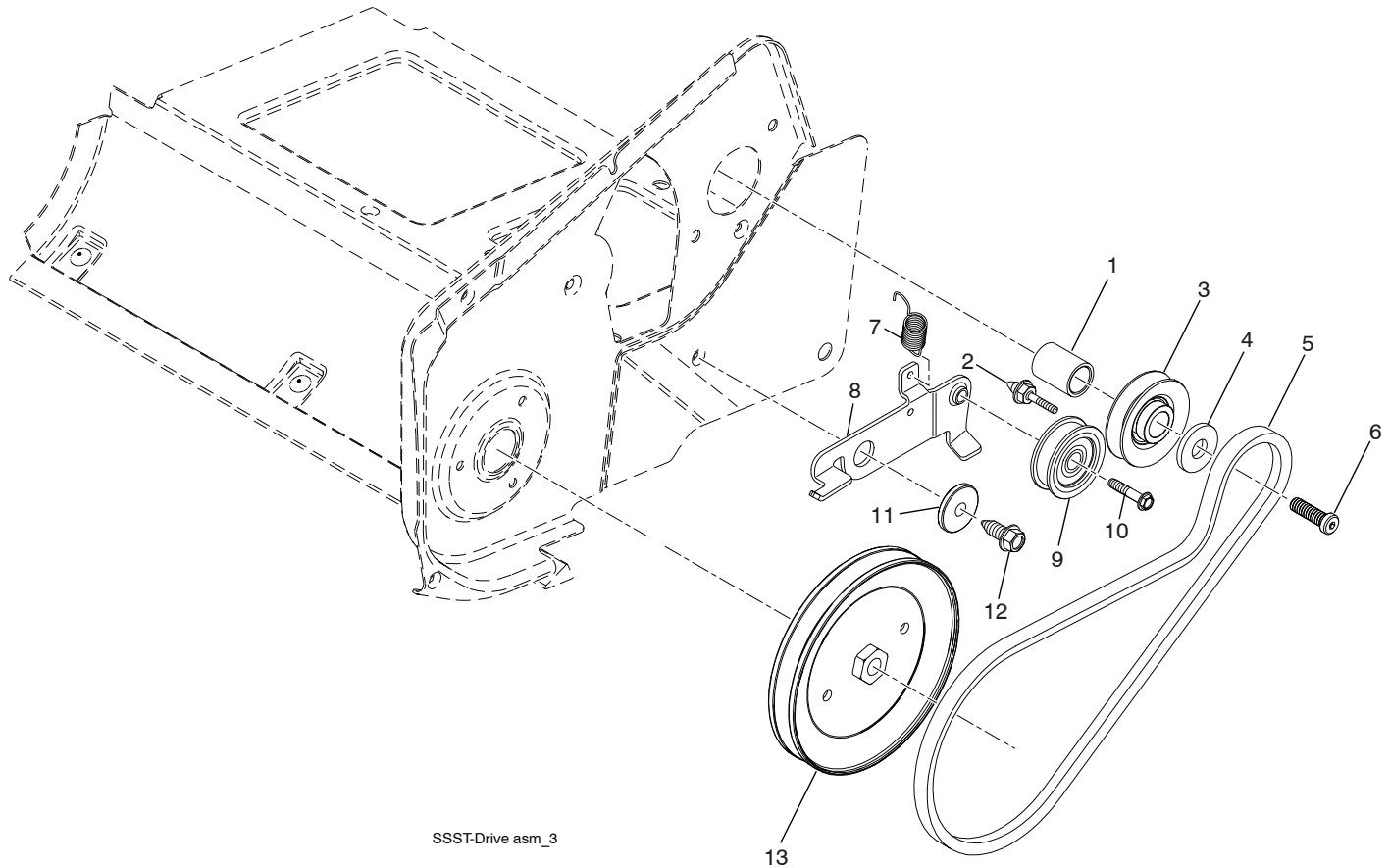

KEY NO.	PART NO.	QTY	DESCRIPTION
1	532 43 48-60	1	SPACER.ENGINE.CRANK
2	532 43 45-02	1	KEEPER.ENGINE.BELT
3	532 42 64-90	1	PULLEY.ENG.TRACTION.3/4
4	532 85 10-74	1	WASHER.HARDEN
5	532 43 72-61	1	BELT-V.TRACTION
6	532 43 08-17	1	SCREW.CAPSCHD.3/8-24 X 1.25
7	532 43 48-59	1	SPRING.IDLER.PULLEY.RETURN
8	532 43 76-09	1	ARM.IDLER.PNT.MS431
9	532 16 60-43	1	PULLEY.IDLER.BACKSIDE
10	817 06 06-20	1	SCREW.HXWH.THDR.1/4-20X1-1/4
11	532 19 90-92	1	SPACER.RETAINER
12	817 06 06-20	1	SCREW.3/8-16X1.SMGML.TAP/R.BLK
13	532 43 53-83	1	PULLEY.DRIVEN
--	532 17 45-72	1	DECAL.SPARK.CANADA
--	532 43 64-09	1	OWNER'S.MANUAL.ENGLISH/FRENCH

**NOTE:** All component dimensions given in U.S. inches. 1 inch = 25.4 mm  
**IMPORTANT:** Use only Original Equipment Manufacturer (O.E.M.) replacement parts. Failure to do so could be hazardous, damage your snow thrower and void your warranty.

---

# SERVICE NOTES

---

## LIMITED WARRANTY

The Manufacturer warrants to the original consumer purchaser that this product as manufactured is free from defects in materials and workmanship. For a period of two (2) years from date of purchase by the original consumer purchaser, we will repair or replace, at our option, without charge for parts or labor incurred in replacing parts, any part which we find to be defective due to materials or workmanship. This Warranty is subject to the following limitations and exclusions.

1. This warranty does not apply to the engine, transaxle/transmission components, battery (except as noted below) or components parts thereof. Please refer to the applicable manufacturer's warranty on these items.
2. Transportation charges for the movement of any power equipment unit or attachment are the responsibility of the purchaser. Transportation charges for any parts submitted for replacement under this warranty must be paid by the purchaser unless such return is requested by the manufacturer.
3. Battery Warranty: On products equipped with a Battery, we will replace, without charge to you, any battery which we find to be defective in manufacture, during the first ninety (90) days of ownership. After ninety (90) days, we will exchange the Battery, charging you 1/12 of the price of a new Battery for each full month from the date of the original sale. Battery must be maintained in accordance with the instructions furnished.
4. The Warranty period for any products used for rental or commercial purposes is limited to 90 days from the date of original purchase.
5. This Warranty applies only to products which have been properly assembled, adjusted, operated, and maintained in accordance with the instructions furnished. This Warranty does not apply to any product which has been subjected to alteration, misuse, abuse, improper assembly or installation, delivery damage, or to normal wear of the product.
6. Exclusions: Excluded from this Warranty are belts, blades, blade adapters, normal wear, normal adjustments, standard hardware and normal maintenance.
7. In the event you have a claim under this Warranty, you must return the product to an authorized service dealer.

Should you have any unanswered questions concerning this Warranty, please contact:

HOP  
Outdoor Products Customer Service Dept.  
9335 Harris Corners Parkway  
Charlotte, NC 28269 USA

In Canada contact:  
HOP  
5855 Terry Fox Way  
Mississauga, Ontario  
L5V 3E4

giving the model number, serial number and date of purchase of your product and the name and address of the authorized dealer from whom it was purchased.

THIS WARRANTY DOES NOT APPLY TO INCIDENTAL OR CONSEQUENTIAL DAMAGES AND ANY IMPLIED WARRANTIES ARE LIMITED TO THE SAME TIME PERIODS STATED HEREIN FOR OUR EXPRESSED WARRANTIES. Some areas do not allow the limitation of consequential damages or limitations of how long an implied Warranty may last, so the above limitations or exclusions may not apply to you. This Warranty gives you specific legal rights, and you may have other rights which vary from locale to locale.

This is a limited Warranty within the meaning of that term as defined in the Magnuson-Moss Act of 1975.

