

# **ILLUSTRATED PARTS LIST**

**MODEL NO. 96051001200**

**CUSTOMER CATALOG NO. M11577HRB**

**PRODUCT NO. 960 51 00-12**

**TRACTOR - MODEL NO. M11577HRB (96051001200), PRODUCT NO. 960 51 00-12  
DECALS 27**

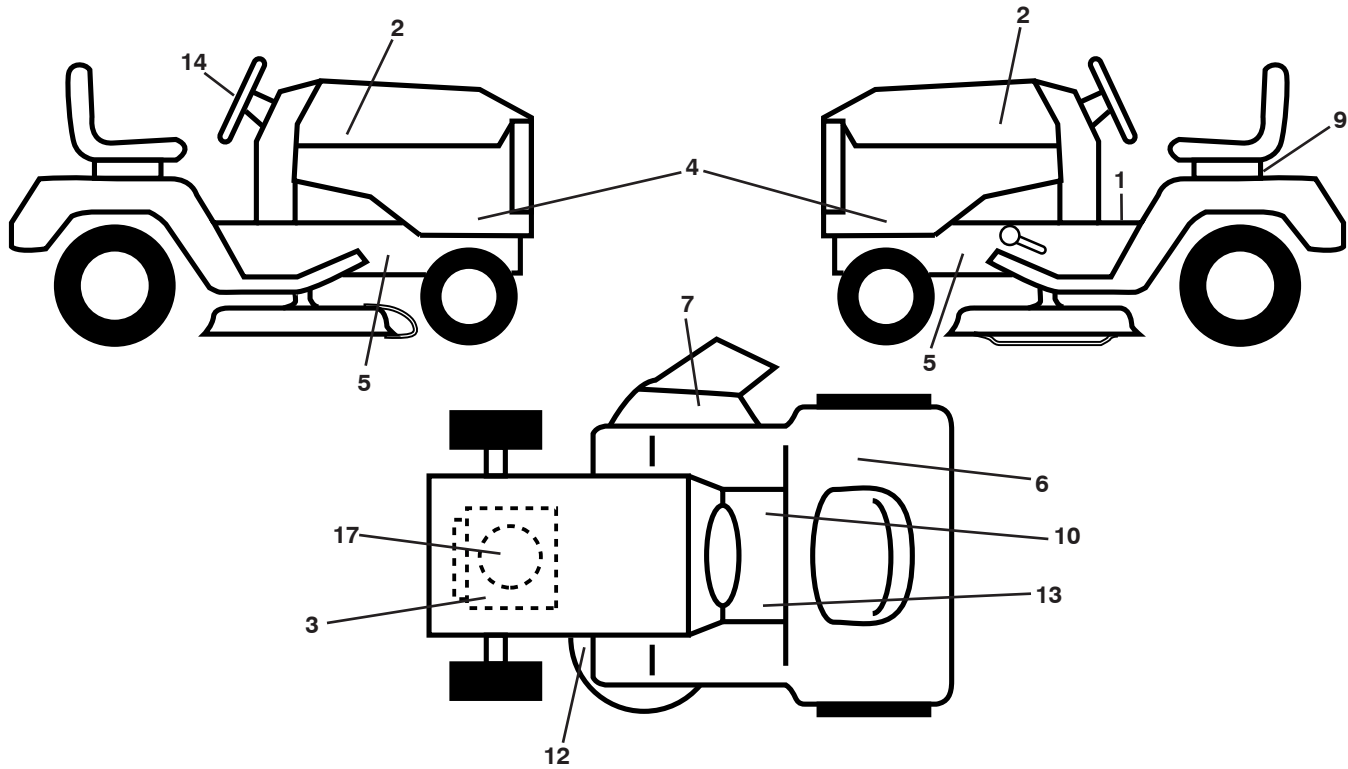

KEY NO.	PART NO.	DESCRIPTION
1	532 40 03-89	Decal, Operators
2	532 43 78-25	Decal, Hood RH/LH
3	532 19 68-41	Decal, Warning Eng. Symbols
4	532 43 78-27	Decal, Hood Panel
5	532 15 97-36	Decal, Chassis Hot Muffler
6	532 18 04-32	Decal, Fender 100 DB/CE
7	532 42 51-13	Decal, Cutfinger
9	532 14 50-05	Decal, Battery Dnge/Poi
10	532 14 08-37	Decal, Saddle Brake Parking
12	532 42 15-43	Decal, Mower V-Belt Schematic

KEY NO.	PART NO.	DESCRIPTION
13	532 15 97-37	Decal, Brake/Clutch Symbol
14	532 43 79-66	Decal, Wheel Strg.
17	532 43 74-09	Decal, BS
--	532 16 69-60	Decal, Bypass
--	532 42 59-76	Pad, Footrest, LH
--	532 42 59-28	Pad, Footrest, RH
--	532 43 91-67	Manual Oper. Euro
--	532 43 91-68	Manual Oper. Scand
--	532 43 91-69	Manual Oper. E-Bloc
--	532 43 91-70	Manual Oper. Baltic

**WHEELS AND TIRES**

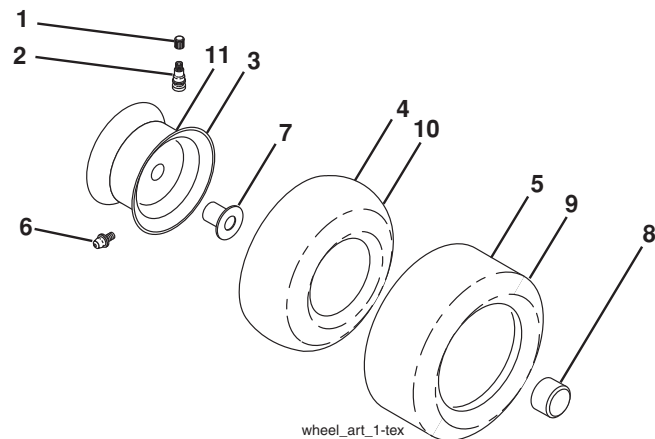

KEY NO.	PART NO.	DESCRIPTION
1	532 05 91-92	Cap Valve Tire
2	532 06 51-39	Stem Valve
3	532 42 53-61	Rim Asm 6 x 3.25 Front
4	532 42 16-52	Tube Front 13x5-6 (Service Item Only)
5	532 12 34-10	Tire F T 13 x 5.0 - 6
6	532 12 49-57	Fitting Grease (Front Wheel Only)
7	532 12 49-59	Bearing Flange (Front Wheel Only)
8	532 17 50-39	Cap Axle Blk 1 50 x 1 00
9	532 10 62-30	Tire R 16 x 6.5
10	532 00 71-54	Tube Rear (Service Item Only)
11	532 42 53-62	Rim Asm 8 x 5.375 Rear
--	532 14 43-34	Sealant, Tire (10 oz. Tube)

**NOTE:** All component dimensions are given in U.S. inches.  
1 inch = 25.4 mm

# TRACTOR -MODEL NO. M11577HRB (96051001200), PRODUCT NO. 960 51 00-12 SCHEMATIC **38**

SCH17

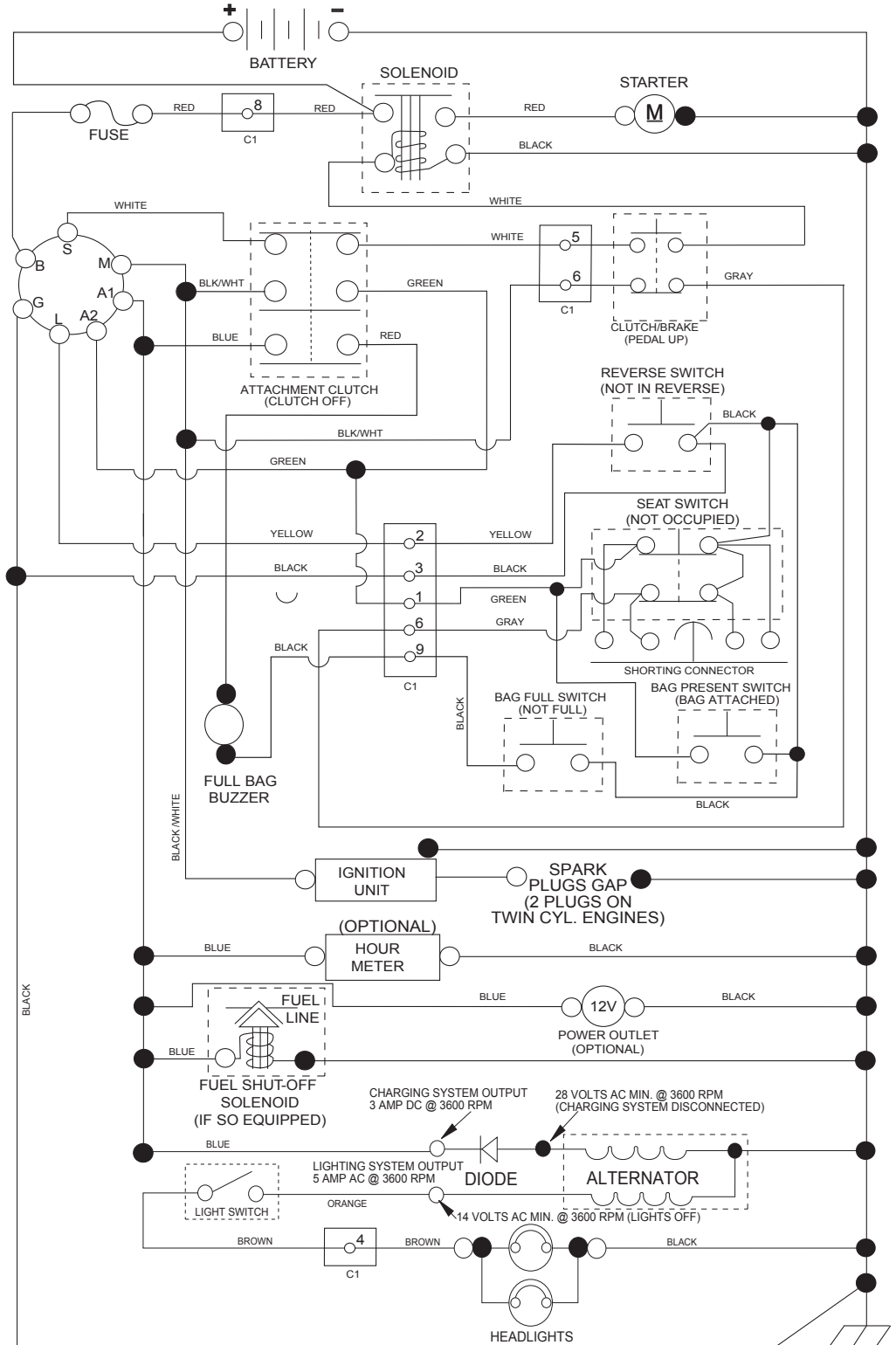

**NOTE**  
YOUR TRACTOR IS EQUIPPED WITH A SPECIAL ALTERNATOR SYSTEM. THE LIGHTS ARE NOT CONNECTED TO THE BATTERY, BUT HAVE THEIR OWN ELECTRICAL SOURCE. BECAUSE OF THIS, THE BRIGHTNESS OF THE LIGHTS WILL CHANGE WITH ENGINE SPEED. AT IDLE THE LIGHTS WILL DIM. AS THE ENGINE SPEED IS INCREASED, THE LIGHTS WILL BECOME THEIR BRIGHTEST.

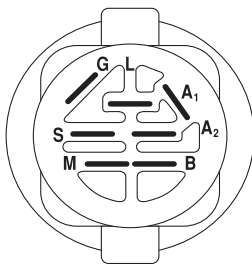

IGNITION SWITCH

POSITION	CIRCUIT	"MAKE"
OFF	M+G+A1	
RUN/OVERRIDE	B+A1	
RUN	B+A1	L+A2
START	B + S + A1	



CHASSIS HARNESS CONNECTOR (C1) (MATING SIDE)

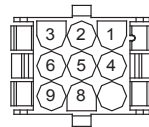

DASH HARNESS CONNECTOR (C1) (MATING SIDE)

WIRING INSULATED CLIPS  
NOTE: IF WIRING INSULATED CLIPS WERE REMOVED FOR SERVICING OF UNIT, THEY SHOULD BE RE-INSTALLED TO PROPERLY SECURE YOUR WIRING.

● NON-REMOVABLE CONNECTIONS

○ REMOVABLE CONNECTIONS

TRACTOR- MODEL NO. M11577HRB (96051001200), PRODUCT NO. 960 51 00-12  
ELECTRICAL **32**

S01S

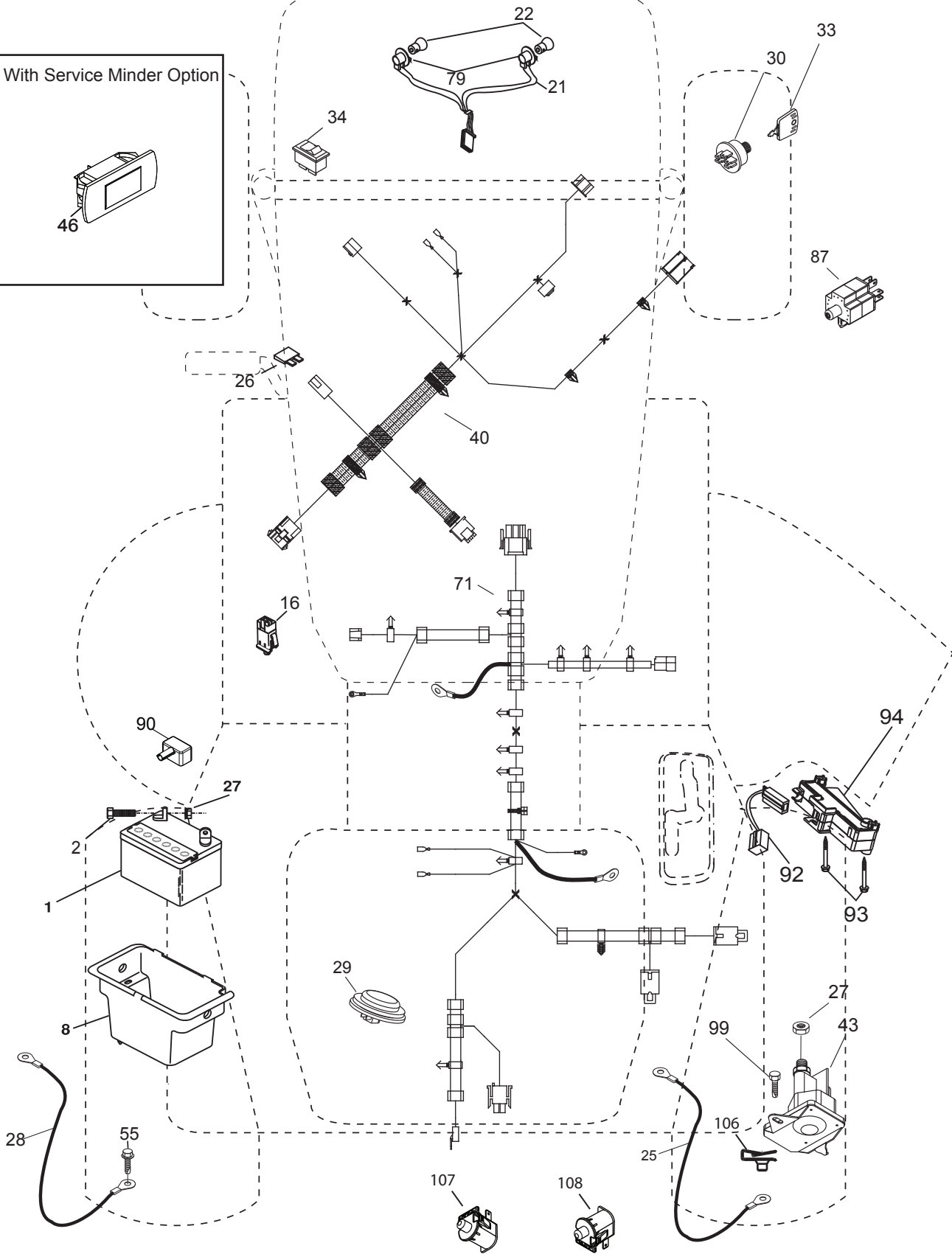
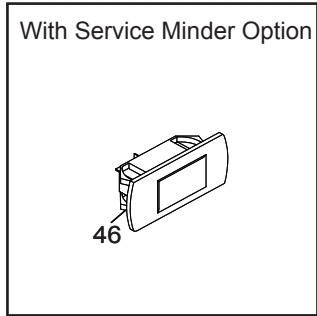

**TRACTOR - MODEL NO. M11577HRB (96051001200), PRODUCT NO. 960 51 00-12  
ELECTRICAL 32**

<b>KEY NO.</b>	<b>PART NO.</b>	<b>DESCRIPTION</b>
1	532 14 49-24	Battery
2	874 76 04-12	Bolt Hex Head 1/4-20 x 3/4
8	532 41 97-91	Box Battery
16	532 17 61-38	Switch Interlock Push-In
21	532 40 02-52	Harness Socket Light w/4152J
22	532 00 41-52	Bulb Light
25	532 41 66-94	Cable Starter
26	532 17 51-58	Fuse
27	873 51 04-00	Nut Keps Hex 1/4-20 unc
28	532 42 16-86	Cable, Ground
29	532 40 15-45	Switch, Seat
30	532 19 33-50	Switch, Ign
33	532 41 19-35	Key/Chain
34	532 11 07-12	Switch Light/Reset
40	532 42 10-02	Harness Ign. Dash
43	532 19 25-07	Solenoid
55	817 06 05-12	Screw Thdrol 5/16-18 x 3/4 TYTT
71	532 42 94-12	Harness Ign. Chassis
79	532 17 52-42	Socket Asm. Bulb
87	532 42 10-60	Switch Railmount NO-NC-NC
90	532 43 53-95	Cover Terminal
92	532 19 66-15	Harness Pigtail Console ROS
93	532 19 25-40	Screw Plastite 10-14 x 2.0
94	532 19 18-34	Module Reverse ROS
99	817 67 04-12	Screw 1/4-20 x 3/4
106	532 17 48-14	Palnut Lugs 1/4
107	532 42 10-61	Switch Snapmount No #2
108	532 42 10-62	Switch Snapmount NC

**NOTE:** All component dimensions given in U.S. inches  
1 inch = 25.4 mm

TRACTOR - MODEL NO. M11577HRB (96051001200), PRODUCT NO. 960 51 00-12  
CHASSIS AND ENCLOSURES **39**

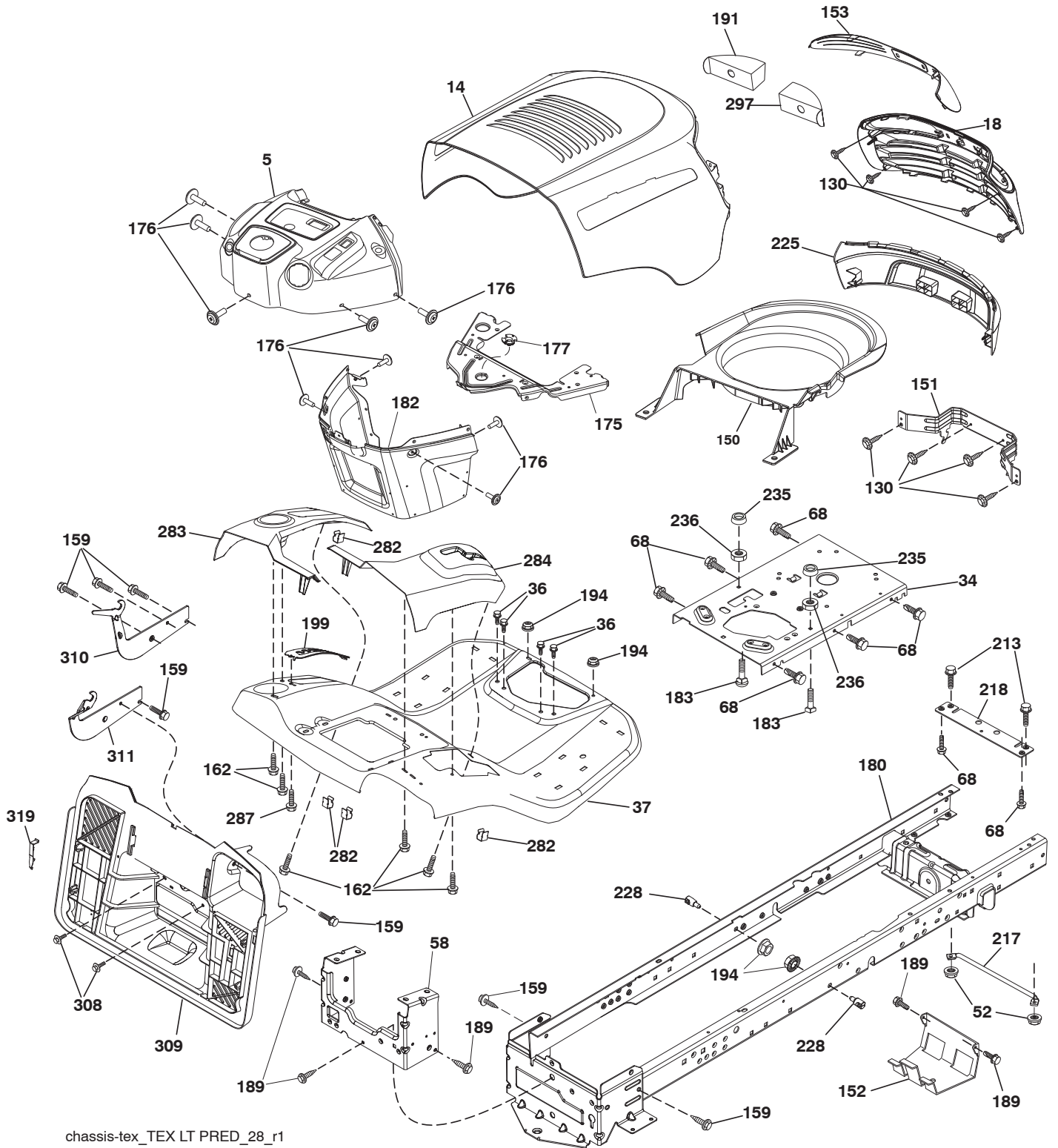

chassis-tex\_TEX LT PRED\_28\_r1

**TRACTOR - MODEL NO. M11577HRB (96051001200), PRODUCT NO. 960 51 00-12  
CHASSIS AND ENCLOSURES 39**

KEY NO.	PART NO.	DESCRIPTION
5	532 42 57-72	Dash
14	532 40 95-98	Hood
18	532 42 65-11	Grille
34	532 19 61-25	Plate Engine
36	817 06 05-12	Screw 5/16-18 x 3/4
37	532 42 59-43	Fender
52	873 68 05-00	Nut Crown Lock 5/16
58	532 41 22-80	Drawbar Upper
68	817 49 05-08	Screw Thdrol. 5/16-18 x 1/2
130	532 41 63-58	Screw #10 x 0.750 BOS Thread
150	532 40 89-56	Air Duct
151	532 18 75-68	Bracket Pivot
152	532 19 95-35	Shield Browning
153	532 40 97-40	Lens
159	817 00 06-12	Screw Kexwsh Thdr 3/8-16 x 3/4
162	532 14 24-32	Screw Hex Wsh. Hi-Lo 1/4 x 1/2 unc
175	532 19 94-72	Crossmember
176	532 40 07-76	Screw 10-24 x 5/8
177	532 19 52-28	Bushing Steering
180	532 41 46-85	Chassis
182	532 40 71-76	Dash Lower
183	874 52 05-20	Bolt 5/16-18 x 1-1/4
189	817 00 05-12	Screw 5/16-18 x 3/4
191	532 40 18-27	Insert Reflective LH
194	873 90 05-00	Nut Lock Hex Flange 5/16-18
199	532 41 87-39	Plate Deck Lift
213	874 76 05-12	Bolt 5/16-18 x 3/4
217	532 40 91-67	Rod Pivot Hood
218	532 19 63-95	X-Piece Hood Stop
225	532 40 95-85	Bumper
228	532 19 51-61	Stud Fastener
235	532 40 61-29	Spacer Fender
236	873 93 05-00	Nut Lock 5/16-18 unc
282	532 41 41-10	Clip Retainer
283	532 42 59-46	Console Deck Lift
284	532 42 59-45	Console Shift
287	817 60 04-06	Screw Hex Washhead 1/4-20 x 3/8
297	532 41 65-02	Insert Reflective RH
308	532 17 18-77	Bolt 5/16-18 unc x 3/4
309	532 43 02-46	Backplate Bagger SRD
310	532 44 66-36	Bracket Hangar Bag LH
311	532 44 66-37	Bracket Hangar Bag RH
319	532 17 46-62	Bracket Actuator Bagger
- -	532 40 37-04	Plug Mount Cargo

**NOTE:** All component dimensions given in U.S. inches  
1 inch = 25.4 mm

TRACTOR - MODEL NO. M11577HRB (96051001200), PRODUCT NO. 960 51 00-12  
DRIVE **40**

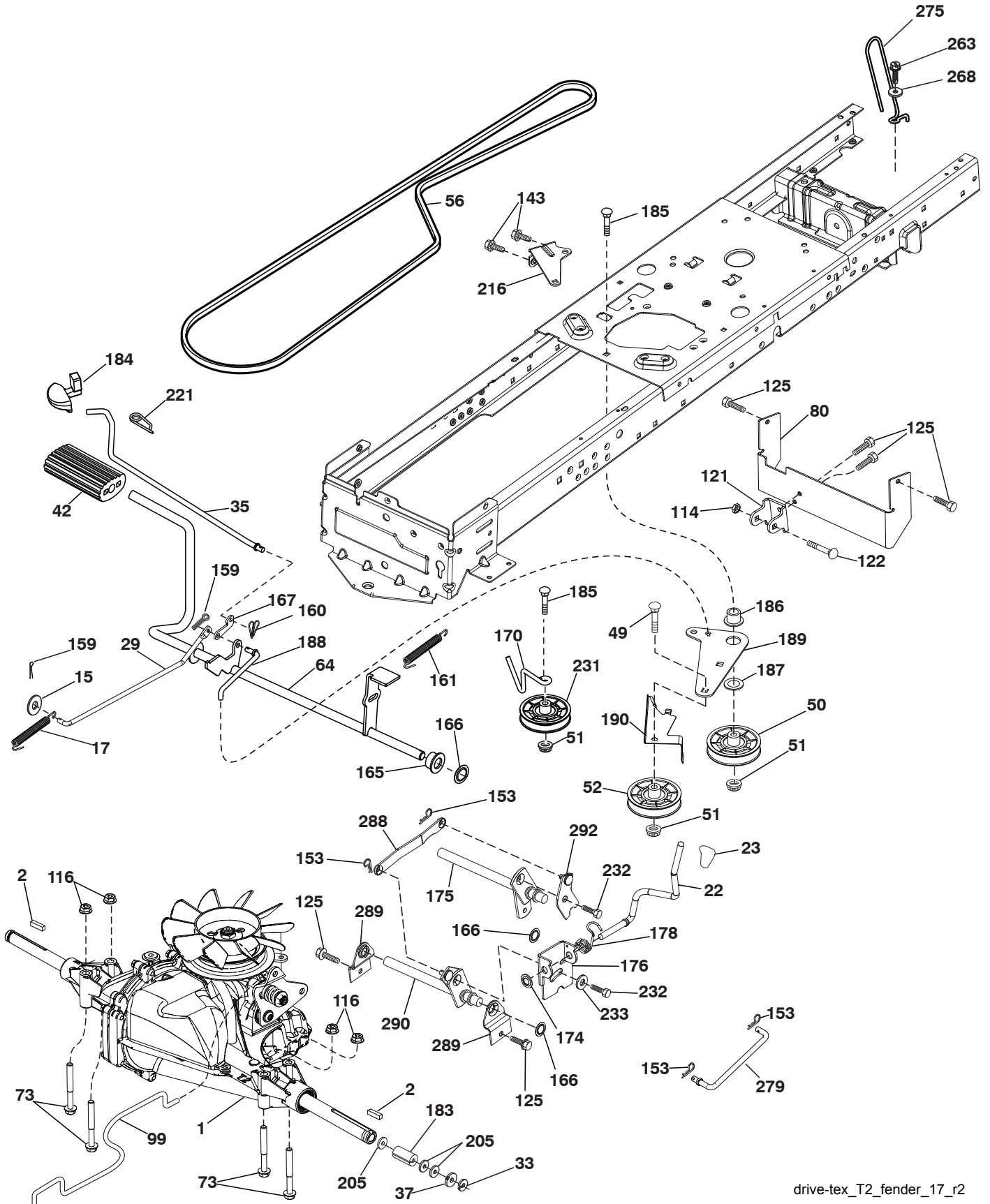

drive-tex\_T2\_fender\_17\_r2



**TRACTOR - MODEL NO. M11577HRB (96051001200), PRODUCT NO. 960 51 00-12  
DRIVE **40****

KEY NO.	PART NO.	DESCRIPTION	KEY NO.	PART NO.	DESCRIPTION
1	-----	Transaxle, Hydro T2-BABC-1X1A-1GX1 (Order parts from transaxle manufacturer.)	166	532 42 91-64	Nut Push .625
2	532 12 35-83	Key	167	532 40 52-57	Latch Brake Parking
15	819 13 13-16	Washer 13/32 x 13/16 x 16 Ga.	170	532 41 34-30	Keeper Belt Centerspan
17	532 19 72-96	Spring, Brake	174	532 19 72-89	Nut Push
22	532 41 66-14	Rod Shift	175	532 40 85-39	Shaft Asm
23	532 12 12-74	Knob	176	532 19 62-14	Asm Clevis Rod Shift
29	532 42 32-39	Rod, Brake	178	532 19 63-14	Spring Shift
33	812 00 00-01	Ring E	183	532 15 69-72	Spacer Axle
35	532 40 10-31	Rod, Brake, Park	184	532 40 97-47	Handle Parking Brake
37	532 12 17-49	Washer 25/32 x 1-1/4 x 16 Ga.	185	872 11 06-22	Bolt
42	532 12 48-72	Cover, Foot Pedal	186	532 19 43-21	Spacer Retainer
49	872 11 06-14	Bolt	187	819 13 32-10	Washer
50	532 19 43-27	Pulley Idler Flat	188	532 19 43-23	Link Clutch Ground Drive
51	873 90 06-00	Lock Nut 3/8-16	189	532 19 43-17	Bellcrank Ground Drive
52	532 19 43-26	Idler V-Groove 910" Offset	190	532 19 43-18	Keeper Bellcrank Ground Drive
56	532 12 59-07	V-Belt, Drive	205	532 12 17-48	Washer 25/32 x 1-5/8 x 16 Ga.
64	532 19 62-00	Shaft Asm. Pedal Brake Control	216	532 19 61-31	Bracket Pulley Idler
73	874 49 05-44	Bolt Hex Flghd 5/16-18 Gr. 5	221	532 40 31-87	Retainer Spring Clip Handle
80	581 55 07-01	Strap Torque	231	532 40 72-87	Idler V-Groove 1.688 Offset
99	532 40 84-18	Rod Asm. Bypass	232	874 78 07-16	Bolt Fin Hex 7/16-14 x 1
114	873 80 05-00	Nut Lock Hex w/INS 5/16-18 unc	233	532 40 52-96	Washer Serrated
116	873 90 05-00	Nut Lock Hex Flange 5/16-18	263	817 00 06-12	Screw HexWsh Thdrol3/8-16x3/4
121	532 17 56-11	Bracket Strap Torque	268	819 13 16-14	Washer 13/32 x 1 x 14
122	872 01 05-20	Bolt 5/16-18 x 2.50	275	532 18 24-02	Guard Muffler
125	817 00 05-12	Screw 5/16-18 x 3/4	279	532 42 41-55	Link Shift
143	817 49 05-08	Screw 5/16-18 x 1/2	288	532 41 66-17	Link Shift Slave
153	532 12 47-88	Retainer Spring 1"	289	532 41 75-20	Bracket Support
159	876 02 04-12	Pin Cotter 1/8 x 3/4	290	532 42 00-14	Shaft Asm. Shift Rear
160	532 16 94-84	Retainer Clip	292	532 41 93-07	Plate Asm. Shift FWD
161	532 10 57-09	Spring, Return, Clutch			
165	532 19 62-12	Bushing			

**NOTE:** All component dimensions given in U.S. inches  
1 inch = 25.4 mm

TRACTOR - MODEL NO. M11577HRB (96051001200), PRODUCT NO. 960 51 00-12  
ENGINE 24

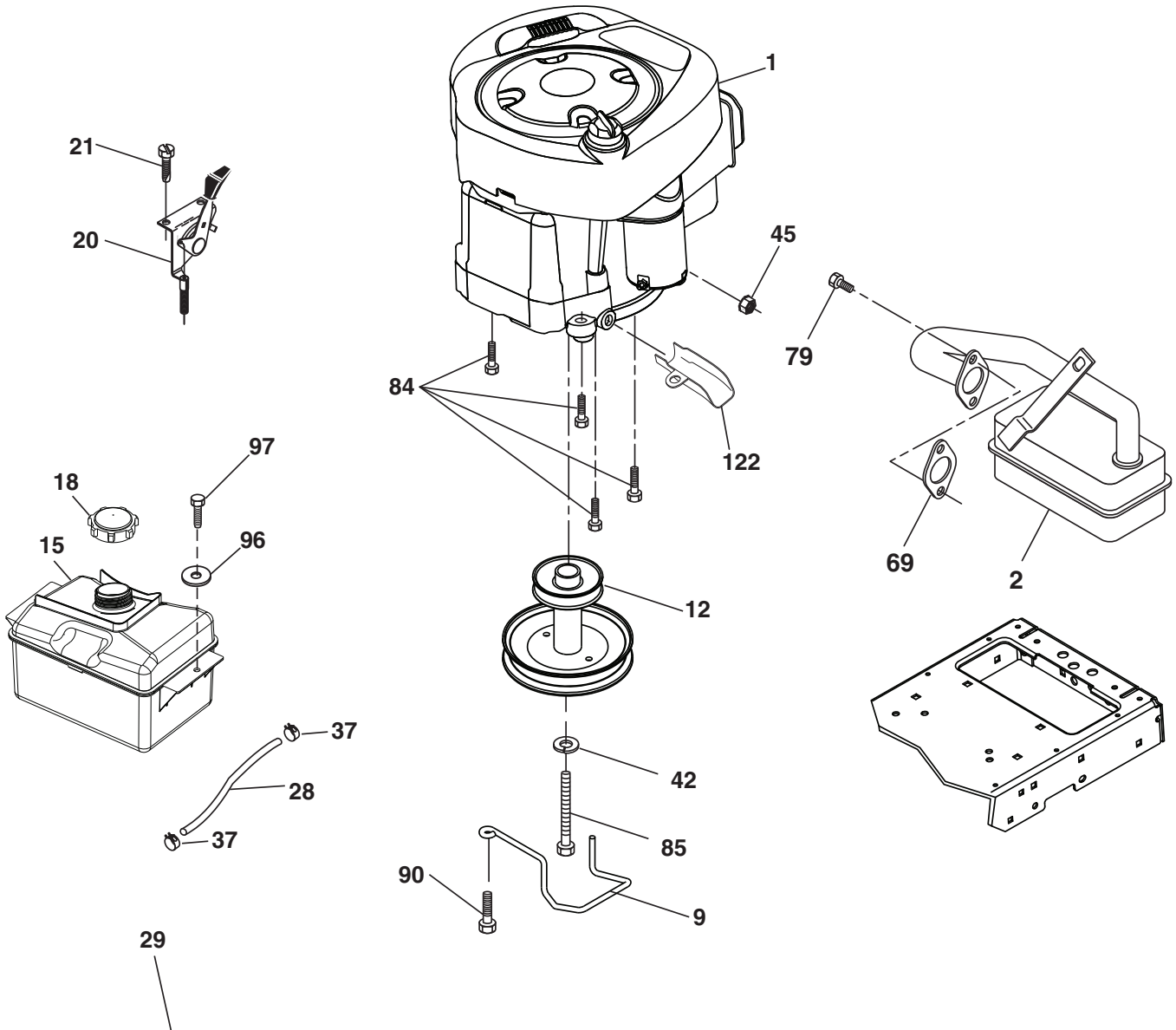

29

**OPTIONAL EQUIPMENT**

**Spark Arrester**

engine-tex\_BS\_36

**TRACTOR - MODEL NO. M11577HRB (96051001200), PRODUCT NO. 960 51 00-12  
ENGINE 24**

KEY NO.	PART NO.	DESCRIPTION
1	-----	Engine BS Model No.217807-1209-B1(Order parts from engine manufacturer.)
2	532 17 97-58	Muffler
9	532 19 43-19	Keeper Belt Engine
12	532 14 01-86	Pulley Engine
15	532 40 75-45	Tank Fuel 1.5
18	532 43 02-20	Cap Fuel
20	532 41 17-24	Control Throttle
21	532 41 63-58	Screw #10 x 0.750 BOS Thread
28	532 13 70-40	Fuel Line
29	532 13 71-80	Spark Arrester Kit
37	532 12 34-87	Clamp Hose
42	810 04 07-00	Washer Lock Hvy HLCL SPR 7/16
45	873 51 04-00	Nut Keps Hex 1/4-20 unc
69	532 16 52-91	Gasket
79	532 19 23-34	Screw Socket HD 5/16 - 18 x 75
84	817 06 06-20	Screw 3/8-16 x 1-1/4
85	532 17 39-37	Bolt Hex 7/16-20 x 4 Gr. 5
90	817 00 06-16	Screw 3/8-16 x 1
96	819 09 14-16	Washer 9/32 x 7/8 x 16 Ga.
97	817 67 04-12	Screw 1/4-20 x 3/4
122	532 42 19-22	Extension Drain Oil

**NOTE:** All component dimensions given in U.S. inches  
1 inch = 25.4 mm

**Engine Power Rating Information**

The gross power rating for individual gas engine models is labeled in accordance with SAE (Society of Automotive Engineers) code J1940 (Small Engine Power & Torque Rating Procedure), and rating performance has been obtained and corrected in accordance with SAE J1995 (Revision 2002-05). Torque values are derived at 3060 RPM; horsepower values are derived at 3600 RPM. Actual gross engine power will be lower and is affected by, among other things, ambient operating conditions and engine-to-engine variability. Given both the wide array of products on which engines are placed and the variety of environmental issues applicable to operating the equipment, the gas engine will not develop the rated gross power when used in a given piece of power equipment (actual "on-site" or net power). This difference is due to a variety of factors including, but not limited to, accessories (air cleaner, exhaust, charging, cooling, carburetor, fuel pump, etc.), application limitations, ambient operating conditions (temperature, humidity, altitude), and engine-to-engine variability. Due to manufacturing and capacity limitations, Briggs & Stratton may substitute an engine of higher rated power for this Series engine.

TRACTOR - MODEL NO. M11577HRB (96051001200), PRODUCT NO. 960 51 00-12  
STEERING ASSEMBLY **41**

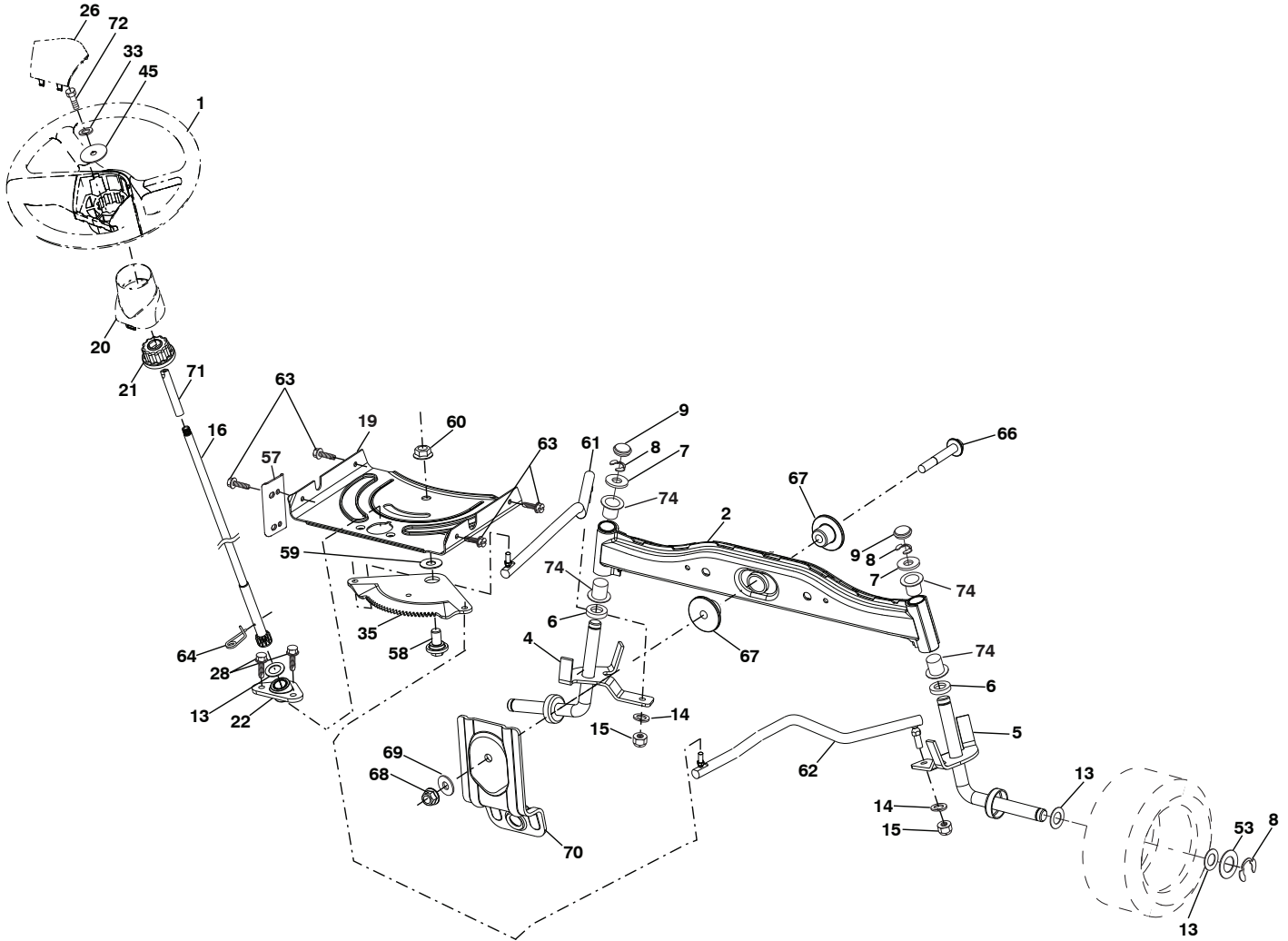

steering-tex\_STDHRS\_8

**TRACTOR - MODEL NO. M11577HRB (96051001200), PRODUCT NO. 960 51 00-12  
STEERING ASSEMBLY **41****

<b>KEY NO.</b>	<b>PART NO.</b>	<b>DESCRIPTION</b>
1	532 42 45-43	Wheel, Steering
2	532 41 81-68	Axle Asm., Front
4	532 41 68-45	Spindle Asm., LH
5	532 41 68-46	Spindle Asm., RH
6	532 12 49-31	Bearing, Race Thrust Hardened
7	532 12 17-48	Washer 25/32 x 1-5/8 x 16 Ga.
8	812 00 00-29	Ring, Klip #T5304-75
9	532 12 12-32	Cap, Spindle
13	532 12 17-49	Washer, 25/32 x 1-1/4 x 16 Ga.
14	810 04 06-00	Washer, Lock Hvy Hlcl Spr 3/8
15	873 54 06-00	Nut, Crown Lock 3/8-24 unf
16	532 42 93-73	Shaft Steering
19	532 19 47-29	Plate Steering
20	532 40 97-63	Boot, Steering
21	532 18 67-37	Adapter, Wheel Steering
22	532 42 05-37	Strg. Supt. Lower
26	532 42 41-47	Insert, Wheel Steering
28	817 00 06-12	Screw 3/8-16 x 3/4
33	810 04 05-00	Washer Lock 5/16
35	532 19 47-32	Gear, Sector Plate
45	819 11 38-12	Washer 11/32 x 3/8 x 12 Ga.
53	532 18 89-67	Washer Hardened .793 x 1.637 x .060
57	532 40 74-65	Bracket Upstop
58	532 19 47-47	Bolt Shoulder Sector Pivot CFM
59	532 19 47-48	Washer Thrust Sector Steering
60	873 97 10-00	Nut Flange Lock 5/8-11
61	532 19 47-40	Draglink, LH
62	532 19 47-41	Draglink, RH
63	817 00 05-12	Screw 5/16-18 x 3/4
64	532 19 98-49	Retainer Clip Spring Steering
66	871 02 07-48	Bolt Hex Fghd 7/16-14 x 3 Serr
67	532 19 47-37	Bushing PM Front Axle
68	873 90 07-00	Nut Lock Flange 7/16-14 Gr. 5
69	532 19 91-62	Washer 1.5 x .505 x .118
70	532 41 70-65	Bracket Deck Susp. Front
71	532 19 07-52	Shaft Extension Steering
72	532 42 89-82	Bolt Fin Hex 5/16-18 x 4 w/Patch
74	532 12 49-37	Bearing

**NOTE:** All component dimensions given in U.S. inches  
1 inch = 25.4 mm

TRACTOR - MODEL NO. M11577HRB (96051001200), PRODUCT NO. 960 51 00-12  
MOWER DECK 44

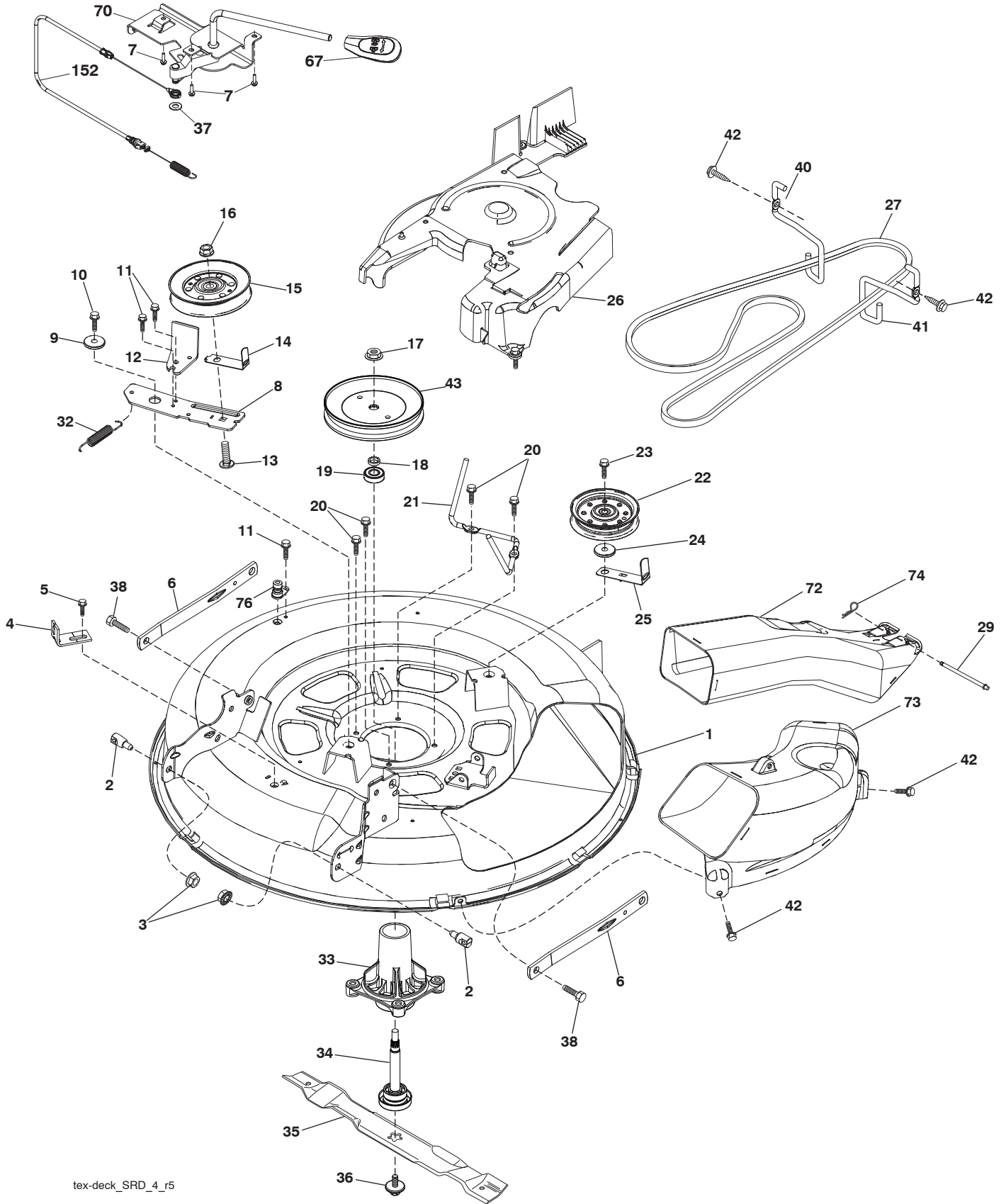

tex-deck\_SRD\_4\_r5

**TRACTOR - MODEL NO. M11577HRB (96051001200), PRODUCT NO. 960 51 00-12  
MOWER DECK 44**

KEY NO.	PART NO. DESCRIPTION	KEY NO.	PART NO. DESCRIPTION
1	532 41 92-72 Deck Weldment 30"Srd	33	532 18 72-81 Housing Mandrel 4pt Service
2	532 19 51-61 Stud Fastner W/"D'anti-Rotatio	34	532 19 28-72 Shaft Asm Mndrl N/Greaseable38
3	873 90 05-00 Nut Lock Hex Flange 5/16-18	35	532 41 92-74 Blade Mower Bagging Srd
4	532 41 76-45 Bracket Clutch Cable	36	532 19 30-03 Bolt/Washer Asm 7/16 - 20 unf
5	817 00 05-10 Bolt 5/16-18	37	819 13 13-16 Washer 13/32 x 13/16 x 16 Ga.
6	532 41 88-63 Arm Susp Mower Rear Srd	38	532 19 65-39 Bolt Shoulder
7	532 41 63-58 Screw #10 x 0.750 BOS Thread	40	532 41 92-70 Keeper Belt Engine LH
8	532 42 02-52 Arm Idler 30"Srd	41	532 41 92-65 Keeper Belt Engine RH
9	532 19 90-92 Spacer Retainer	42	817 00 06-12 ScrewHexwsh THDR3/8-16x3/4BL
10	817 00 06-16 Screw 3/8 - 16 X 1 Smgml Tap/R Blk	43	532 41 68-77 Pulley Mandrel 6 5 Pd 30"
11	532 13 77-29 Screw Thd Roll 1/4-20 X 5/8	67	532 40 97-92 Handle clutch cable
12	532 19 94-70 Arm Brake Mower 38" RH Tex	70	532 40 12-46 Clutch Asm. Manual
13	872 11 06-12 Bolt Carr Sh 3/8-16 X 1-1/2 Gr. 5	72	532 41 72-36 Chute Upper SRD 30R
14	532 15 60-85 Keeper Belt Idler	73	532 42 52-74 Chute Lower SRD 30R
15	532 14 67-63 Pulley Idler V-Groove Dim 4.25	74	532 12 46-70 Retainer Spring
16	873 90 06-00 Nut Lock FIG 3/8 - 16 unc	76	532 41 55-98 Port Washout
17	532 40 02-34 Nut Flange Lock Top	152	532 43 51-11 Manual Clutch Cable
18	532 18 76-90 Washer Spacer Mandrel	--	532 19 28-70 Mandrel Assembly (Includes Hous- ing, Shaft Assembly, And Bearing Only - Pulley/Nut/Washer And Blade Bolt/Washers Not Included)
19	532 11 04-85 Bearing Ball Mandrel	--	532 43 15-50 Replacement Mower Complete
20	532 17 39-84 Screw Thd Roll Dod Pt Hex		
21	532 41 69-10 Keeper Belt Mandrel 30"		
22	532 19 31-98 Pulley Idler Flat Unplated		
23	817 49 06-28 Screw Thdrol 3/8-16 X 1-3/4		
24	819 13 20-12 Washer 13/32 X 1-1/4 X 12 Ga		
25	532 42 02-53 Keeper Belt 30"Srd		
26	532 43 03-13 Cover Mandrel Mwr 30"Black		
27	532 41 92-71 V-Belt Drive		
29	532 42 08-95 Hinge Pin		
32	532 40 18-72 Spring Return Deck 38/46"		

**NOTE:** All component dimensions given in U.S. inches  
1 inch = 25.4 mm

**TRACTOR - MODEL NO. M11577HRB (96051001200), PRODUCT NO. 960 51 00-12**  
**MOWER LIFT 45**

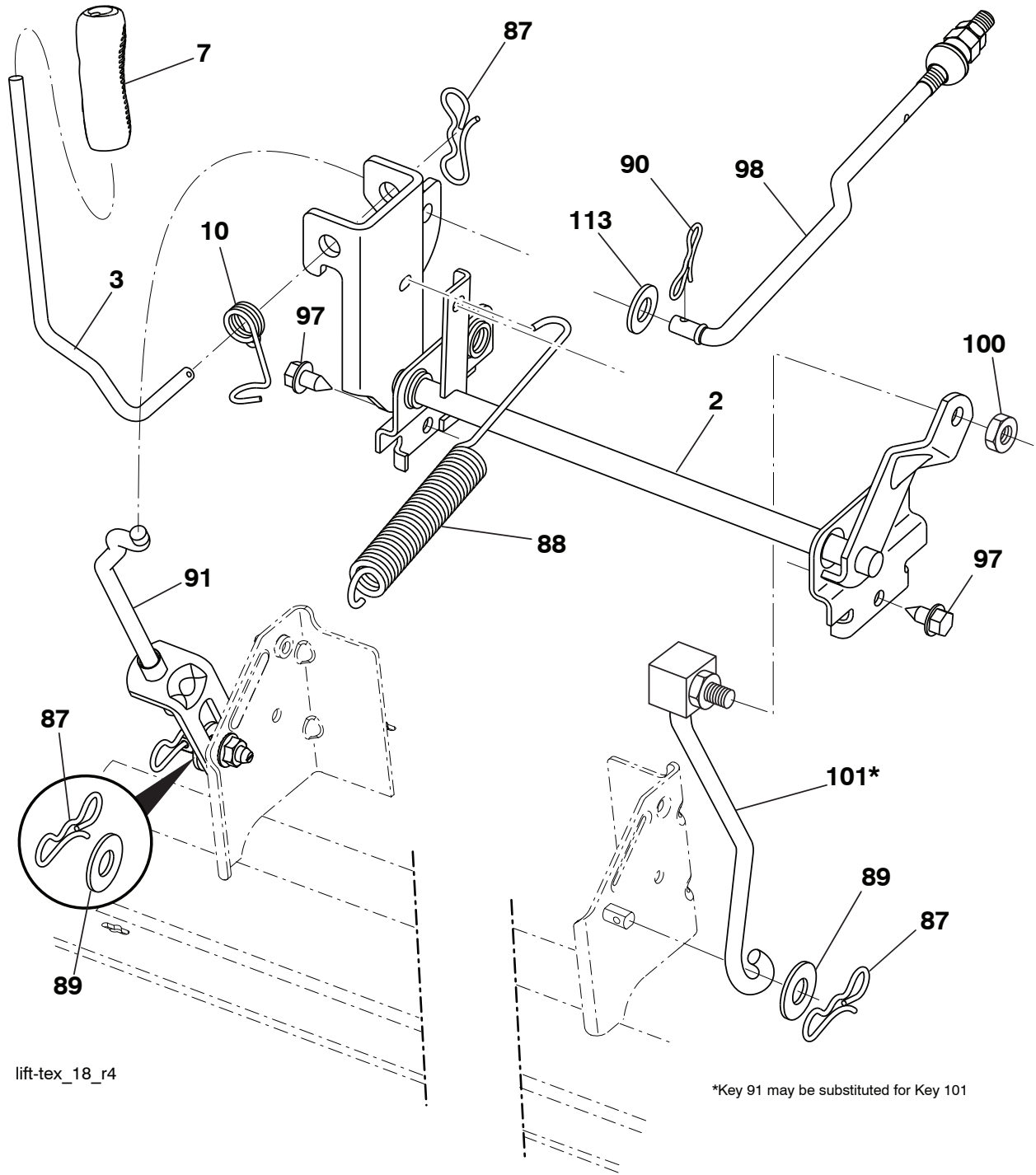

lift-tex\_18\_r4

\*Key 91 may be substituted for Key 101

KEY NO.	PART NO.	DESCRIPTION
2	532 42 20-27	Shaft Asm., Lift
3	532 19 52-31	Lever Asm., Lift RH
7	532 41 17-42	Grip, Lever
10	532 19 63-14	Spring Torsion
87	532 19 42-09	Pin Cotter 7/16 Bow Tie Lock
88	532 41 07-10	Spring Lift Assist
89	819 19 19-12	Washer Clear
90	532 19 42-08	Pin Cotter 5/16 Bow Tie Lock
91	532 19 51-81	Link Lift Susp Mower Rear

KEY NO.	PART NO.	DESCRIPTION
97	817 00 06-12	Screw 3/8-16 x 3/4
98	532 19 52-64	Link Lift Susp. Front Mower
100	873 93 06-00	Nut Centerlock 3/8-16
101	532 40 70-03	Link Asm Lift FXD
113	819 17 19-12	Washer 17/32 x 1-3/16 x 12 Ga.

**NOTE:** All component dimensions given in U.S. inches  
 1 inch = 25.4 mm



**TRACTOR - MODEL NO. M11577HRB (96051001200), PRODUCT NO. 960 51 00-12  
SEAT ASSEMBLY 42**

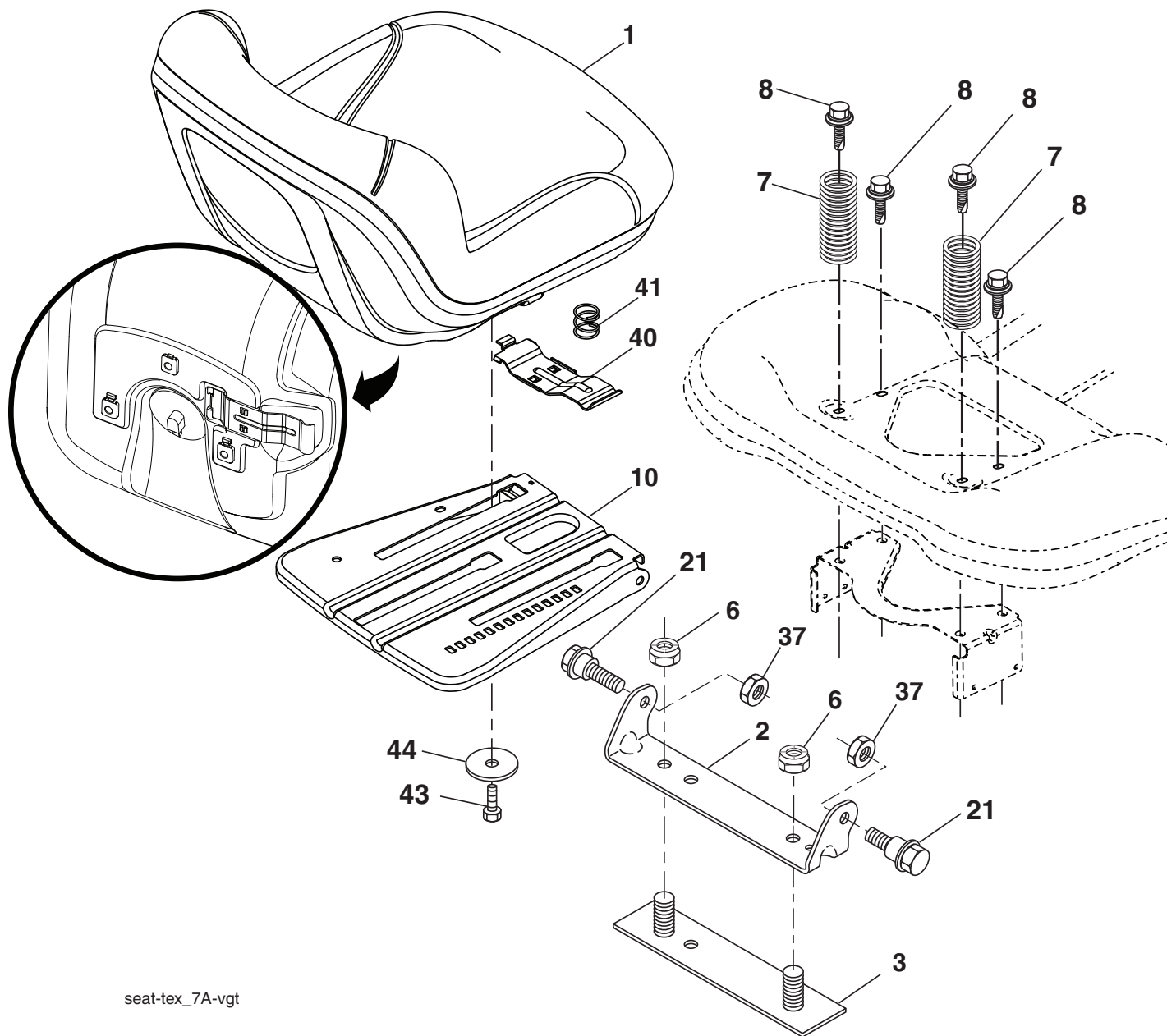

seat-tex\_7A-vgt

KEY NO.	PART NO.	DESCRIPTION
1	532 19 75-11	Seat
2	532 18 01-66	Bracket Pivot Fender
3	532 14 06-75	Strap, Asm Fender
6	873 80 06-00	Nut, Lock w/Ins. 3/8-16 unc
7	532 12 41-81	Spring, Seat Cprsn
8	532 17 18-77	Bolt 5/16-18 unc x 3/4 w/Sems
10	532 19 69-77	Pan, Seat
21	532 17 18-52	Bolt, Shoulder 5/16-18

KEY NO.	PART NO.	DESCRIPTION
37	873 80 05-00	Nut, Lock 5/16-18 unc
40	532 19 76-61	Handle Slide Seat
41	532 19 82-00	Spring Latch Seat
43	874 76 06-12	Bolt 3/8-16 x 3/4
44	819 13 38-12	Washer 13/32 x 2-3/8 x 12 Ga.

**NOTE:** All component dimensions given in U.S. inches  
1 inch = 25.4 mm

TRACTOR - MODEL NO. M11577HRB (96051001200), PRODUCT NO. 960 51 00-12  
BAGGER **46**

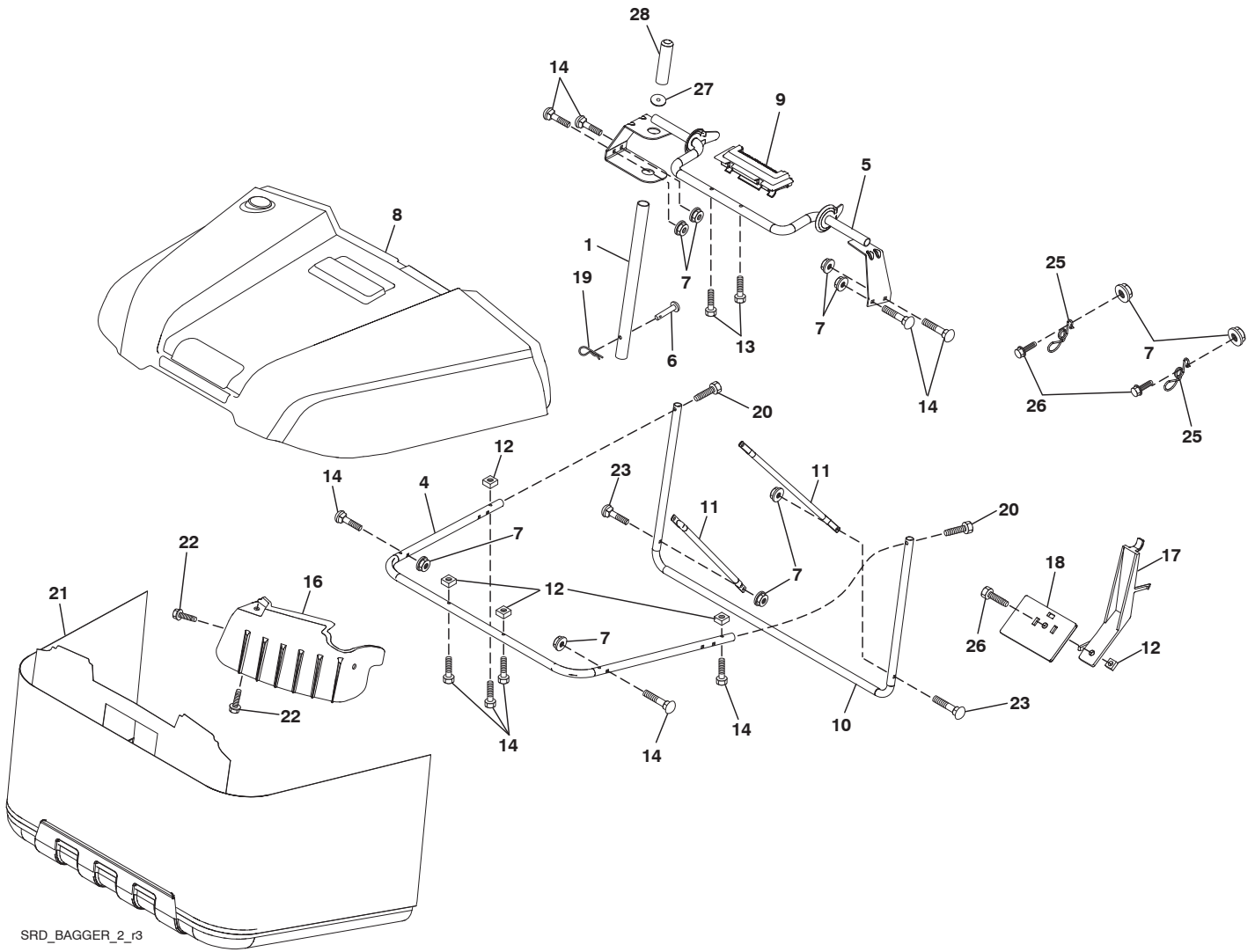

SRD\_BAGGER\_2\_r3

**TRACTOR - MODEL NO. M11577HRB (96051001200), PRODUCT NO. 960 51 00-12  
BAGGER 46**

<b>KEY NO.</b>	<b>PART NO.</b>	<b>DESCRIPTION</b>
1	532 42 86-10	Tube Handle Bagger SRD
4	532 43 96-12	Frame Asm Bagger Top
5	532 41 76-32	Frame Asm Top Bagger SRD
6	532 12 68-75	Drilled Rivit
7	873 90 04-00	Nut Hex Flange 1/4-20 unc
8	532 42 59-54	Cover Bagger SRD
9	532 41 76-29	Insert Handle Bagger
10	532 41 71-90	Frame Front
11	532 41 71-88	Tubing Brace Bagger
12	532 42 17-93	Nut Square 1/4
13	532 42 17-80	Screw 1/4 x 1.150 HXWSH
14	532 42 18-00	Bolt Shoulder HX WSH 1/4 x 1.150
16	532 42 15-66	Deflector Bagger
17	532 42 17-49	Lever Bagger Full
18	532 42 17-50	Paddle Bagger Full
19	532 19 42-08	Pin Cotter 5/16 Bow Tie Lock
20	585 36 88-01	Screw Hex Cap 1/4-20 x 1.375
21	532 42 99-83	Bag Asm SRD
22	532 14 24-32	Screw Hex WSH Hi-Lo 1/4 - 1/2 unc
23	872 04 04-10	Bolt Carr 1/4-20 unc x 1-1/4
25	532 42 16-14	Spring Latch Bagger
26	817 49 04-12	Screw Hex Thdrol 1/4-20 x 3/4
27	532 42 12-62	Grommet, Rubber SRD
28	532 16 57-87	Grip Handle Black

**NOTE:** All component dimensions given in U.S. inches  
1 inch = 25.4 mm

