

ILLUSTRATED PARTS LIST

MFG. ID NO. 96041021200

CUSTOMER CATALOG NO. M13577H

PRODUCT NO. 960 41 02-12

**TRACTOR - - MODEL NUMBER M13577H (96041021200), PRODUCT NO. 960 41 02-12
DECALS**

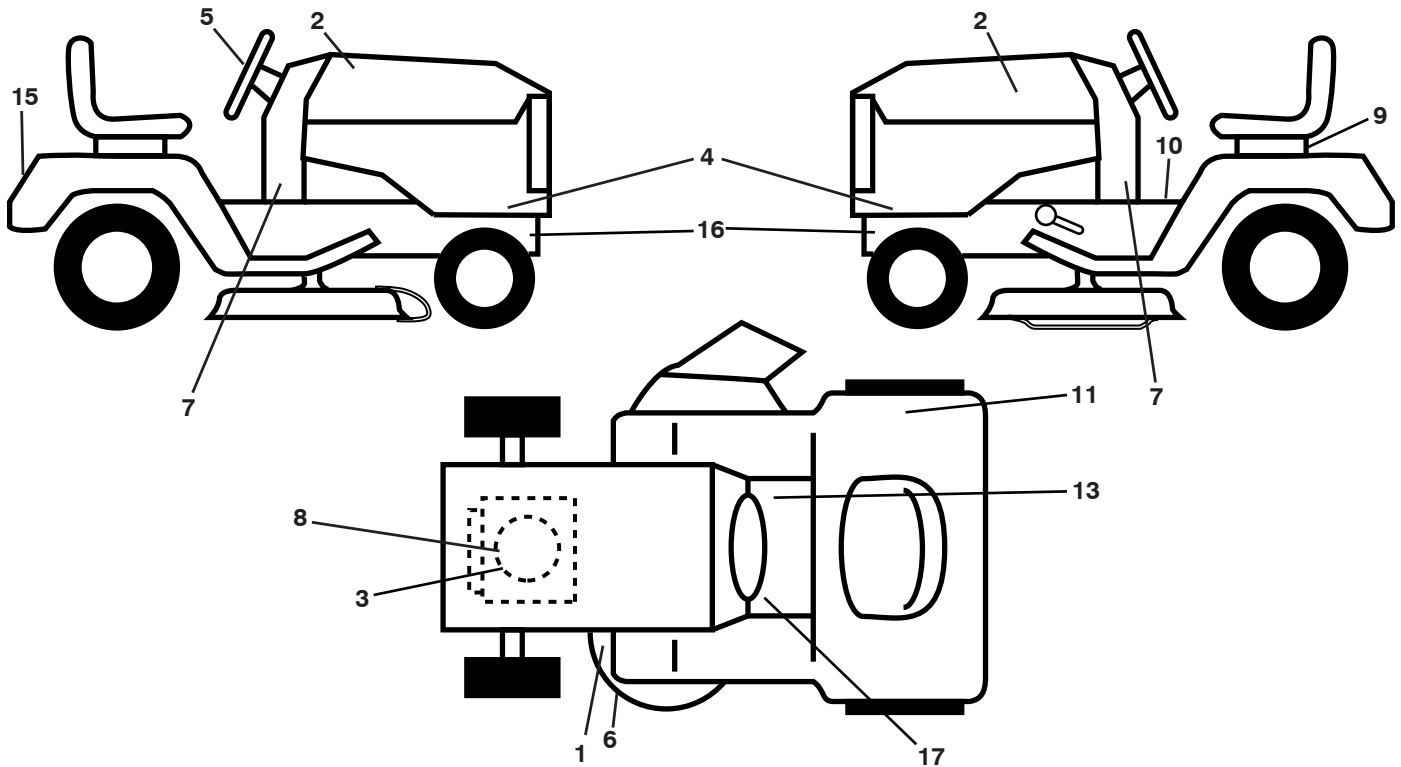

KEY NO.	PART NO.	DESCRIPTION
1	532 42 51-12	Decal, Warning Cutfinger
2	532 43 83-82	Decal, Hood Logo RH/LH
3	532 40 88-10	Decal, Engine HP
4	532 43 83-81	Decal, SDPNL
5	532 43 79-66	Decal, STR WHL
6	532 42 15-43	Decal, V-Belt Schematic
7	532 18 56-51	Decal, Chass. Turbo Collection
8	532 19 68-41	Decal, Engine Warning Symbols
9	532 14 50-05	Decal, Battery Dnge/Poi
10	532 40 03-89	Decal, Warning Symbols

KEY NO.	PART NO.	DESCRIPTION
11	532 18 04-32	Decal, DB/CE 100
13	532 14 08-37	Decal, Saddle Brake Parking
15	532 43 78-33	Decal, Fender
16	532 15 97-36	Decal, Hot Muffler
17	532 15 97-37	Decal, Brake Clutch Symbol
--	532 16 25-98	Decal, Drawbar Load Limit
--	532 16 69-60	Decal, Bypass
--	532 40 95-05	Pad, Footrest, LH
--	532 41 12-73	Pad, Footrest, RH
--	532 43 83-22	Manual Operator's English/Spanish
--	532 43 83-23	Manual Operator's Portuguese

WHEELS AND TIRES

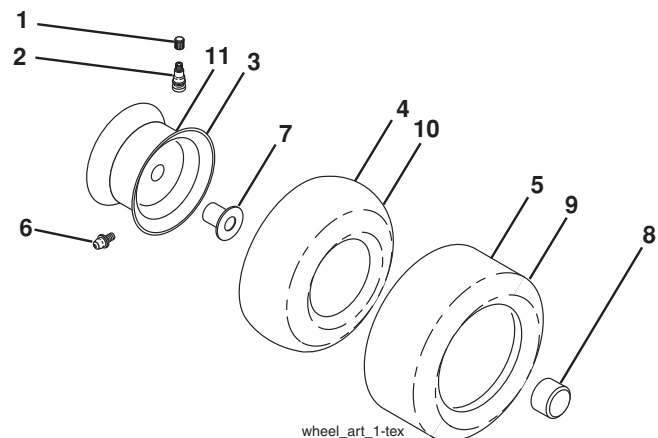

KEY NO.	PART NO.	DESCRIPTION
1	532 05 91-92	Cap Valve Tire
2	532 06 51-39	Stem Valve
3	532 42 53-61	Rim Asm 6" x 3.25 Front
4	532 42 16-52	Tube Front (Service Item Only)
5	532 12 34-10	Tire Front 13 x 5.0-6
6	532 12 49-57	Fitting Grease (Front Wheel Only)
7	532 12 49-59	Bearing Flange (Front Wheel Only)
8	532 17 50-39	Cap Axle Blk 1 50 x 1 00
9	532 10 62-30	Tire Rear 16 x 6 - 5
10	532 00 71-54	Tube Rear (Service Item Only)
11	532 42 53-62	Rim Asm 8" x 5.375 Rear
--	532 14 43-34	Sealant, Tire (10 oz. Tube)

NOTE: All component dimensions given in U.S. inches
1 inch = 25.4 mm

TRACTOR - - MODEL NUMBER M13577H (96041021200), PRODUCT NO. 960 41 02-12 SCHEMATIC

SCH11

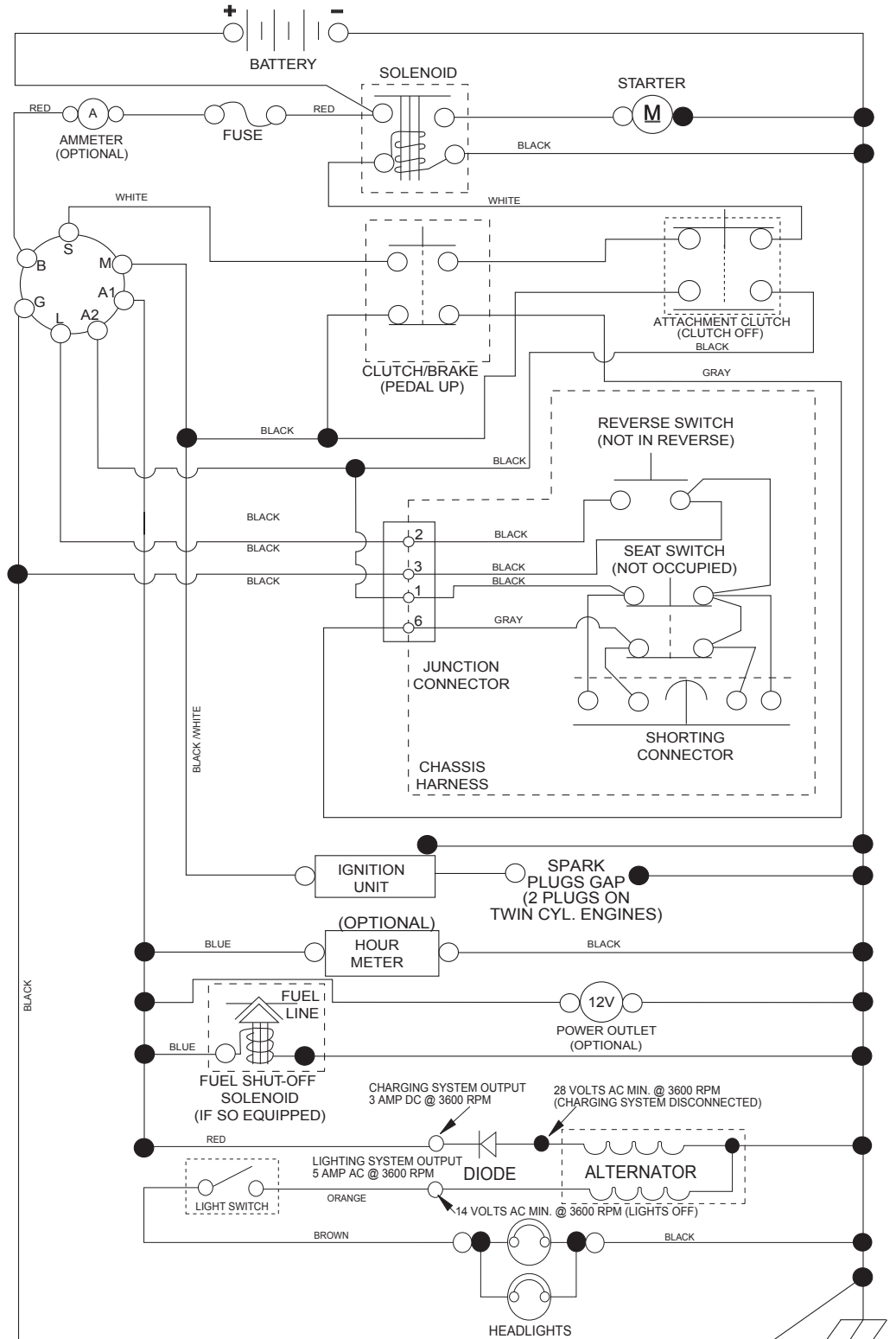

NOTE
YOUR TRACTOR IS EQUIPPED WITH A SPECIAL ALTERNATOR SYSTEM. THE LIGHTS ARE NOT CONNECTED TO THE BATTERY, BUT HAVE THEIR OWN ELECTRICAL SOURCE. BECAUSE OF THIS, THE BRIGHTNESS OF THE LIGHTS WILL CHANGE WITH ENGINE SPEED. AT IDLE THE LIGHTS WILL DIM. AS THE ENGINE IS SPEEDED UP, THE LIGHTS WILL BECOME THEIR BRIGHTEST.

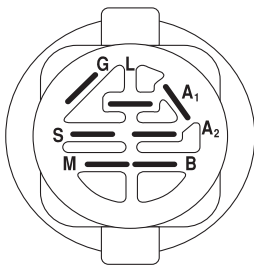

IGNITION SWITCH

POSITION	CIRCUIT	"MAKE"
OFF	M+G+A1	
RUN/OVERRIDE	B+A1	
RUN	B+A1	L+A2
START	B+S+A1	

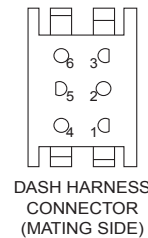
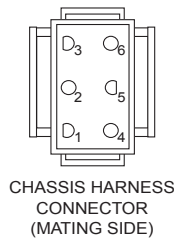

WIRING INSULATED CLIPS
NOTE: IF WIRING INSULATED CLIPS WERE REMOVED FOR SERVICING OF UNIT, THEY SHOULD BE RE-INSTALLED TO PROPERLY SECURE YOUR WIRING.

NON-REMOVABLE CONNECTIONS

REMOVABLE CONNECTIONS

**TRACTOR -- MODEL NUMBER M13577H (96041021200), PRODUCT NO. 960 41 02-12
ELECTRICAL**

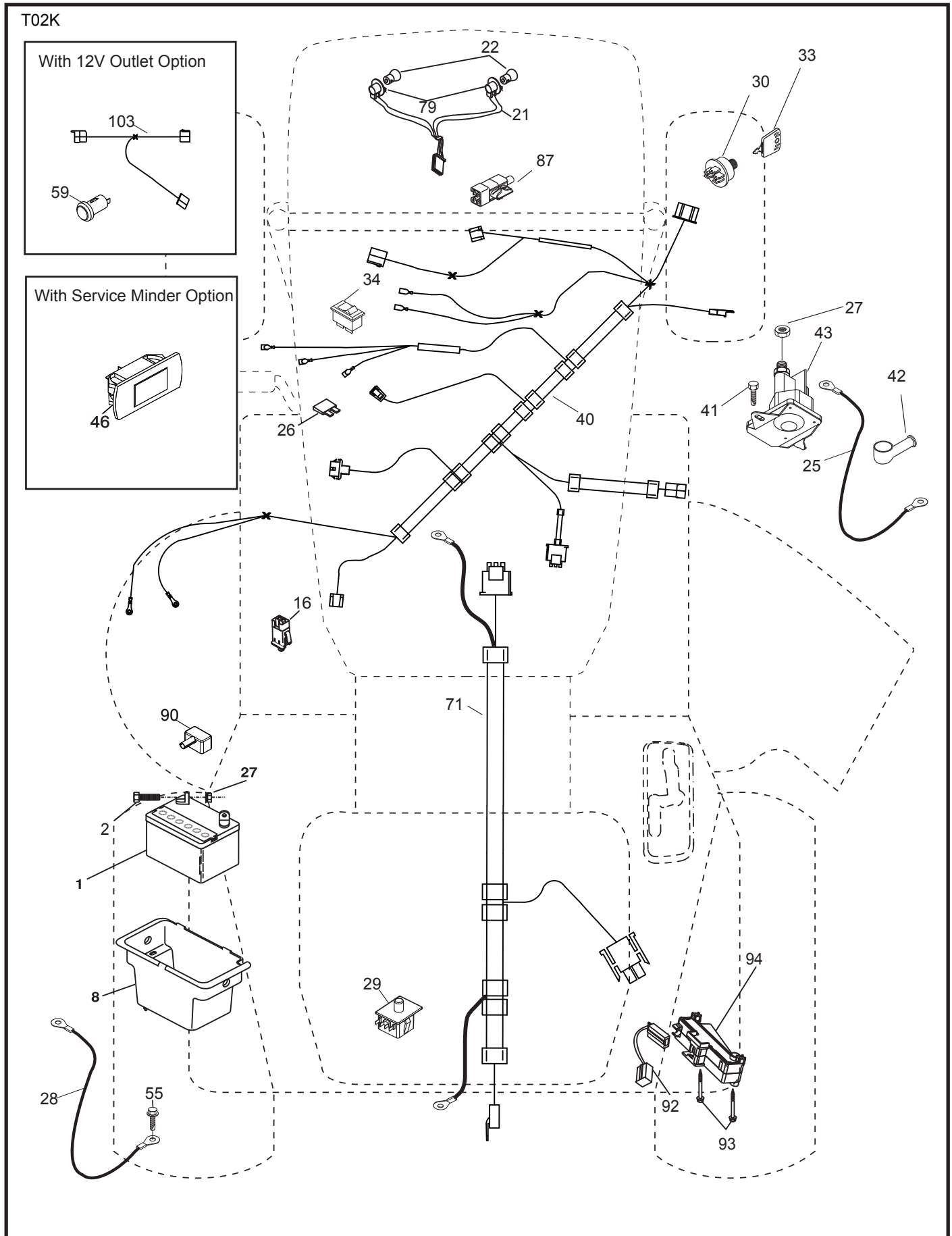

**TRACTOR - - MODEL NUMBER M13577H (96041021200), PRODUCT NO. 960 41 02-12
ELECTRICAL**

KEY NO.	PART NO.	DESCRIPTION
1	532 14 49-24	Battery
2	874 76 04-12	Bolt Hex Head 1/4-20 x 3/4
8	532 19 32-28	Box Battery
16	532 17 61-38	Switch Interlock Push-In
21	532 18 37-59	Harness Socket Light w/4152J
22	532 00 41-52	Bulb Light
25	532 41 28-94	Cable Starter
26	532 17 51-58	Fuse
27	873 51 04-00	Nut Keps Hex 1/4-20 unc
28	532 19 88-85	Cable, Ground
29	532 19 27-49	Switch, Seat
30	532 19 33-50	Switch, Ign
33	532 41 19-33	Key/Chain
34	532 11 07-12	Switch Light/Reset
40	532 40 10-98	Harness Ign. Dash
41	817 72 04-08	Screw Thd Cut 1/4-20 x 1/2
42	532 13 15-63	Cover, Terminal
43	532 19 25-07	Solenoid
55	817 06 05-12	Screw Thdrol 5/16-18 x 3/4
71	532 40 04-49	Harness Chassis
79	532 17 52-42	Socket Asm Bulb Twistlock
87	532 19 78-02	Switch Interlock Clutch Cable
90	532 43 53-95	Cover, Terminal Battery
92	532 19 66-15	Cover, Harness Pigtail Console
93	532 19 25-40	Screw Plastite 10-14 x 2.0
94	532 19 18-34	Module Reverse Console

NOTE: All component dimensions given in U.S. inches
1 inch = 25.4 mm

**TRACTOR -- MODEL NUMBER M13577H (96041021200), PRODUCT NO. 960 41 02-12
CHASSIS**

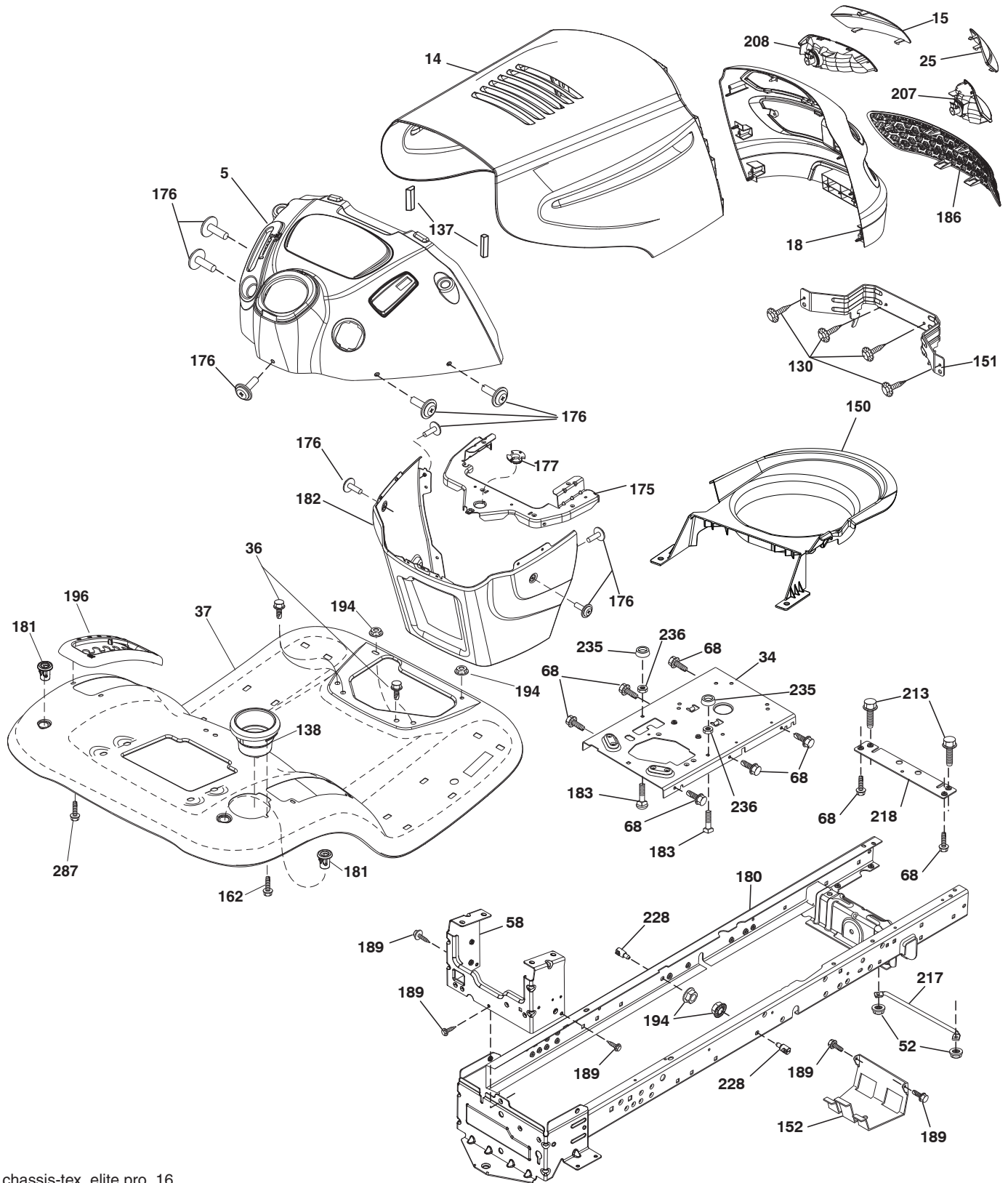

chassis-tex_elite pro_16

**TRACTOR -- MODEL NUMBER M13577H (96041021200), PRODUCT NO. 960 41 02-12
CHASSIS**

KEY NO.	PART NO.	DESCRIPTION
5	532 41 17-64	Dash
14	532 18 65-80	Hood
15	532 18 97-54	Lens Grille LH
18	532 18 97-48	Grille
25	532 18 97-55	Lens Grille RH
34	532 19 61-25	Plate Engine
36	817 06 05-12	Screw 5/16-18 x 3/4
37	532 42 09-86	Fender
52	873 68 05-00	Nut Crown Lock 5/16
58	532 41 22-80	Drawbar, Upper
68	817 49 05-08	Screw THDROL 5/16-18 x 1/2
130	532 41 63-58	Screw #10 x .750 BOS Thread
138	532 40 97-30	Cupholder
137	532 18 49-21	Bumper Hood
150	532 18 44-61	Duct Air
151	532 40 78-07	Bracket Pivot
152	532 19 95-35	Shield Browning
162	532 14 24-32	Screw
175	532 19 32-43	Crossmember
176	532 40 07-76	Screw 10-24 x 5/8
177	532 19 52-28	Bushing Steering
180	532 41 46-85	Chassis
181	532 40 47-96	Bushing Mount Fender Cargo
182	532 19 30-57	Dash Lower
183	874 52 05-20	Bolt 5/16-18 x 1-1/4
186	532 18 97-53	Insert Grille
189	817 00 05-12	Screw 5/16-18 x 3/4
194	873 90 05-00	Nut Lock Hex Flange 5/16-18
196	532 41 45-81	Console Asm. Deck Lift
207	532 18 38-33	Bezel RH
208	532 18 38-32	Bezel LH
213	874 76 05-12	Bolt 5/16-18 x 3/4
217	532 40 91-67	Rod Pivot Hood
218	532 19 63-95	X-Piece Hood Stop
228	532 19 51-61	Stud Fastener
235	532 40 61-29	Spacer Fender
236	873 93 05-00	Nut Lock 5/16-18 unc
287	817 60 04-06	Screw Hex Washhead 1/4-20 x 3/8

NOTE: All component dimensions given in U.S. inches
1 inch = 25.4 mm

TRACTOR -- MODEL NUMBER M13577H (96041021200), PRODUCT NO. 960 41 02-12
DRIVE

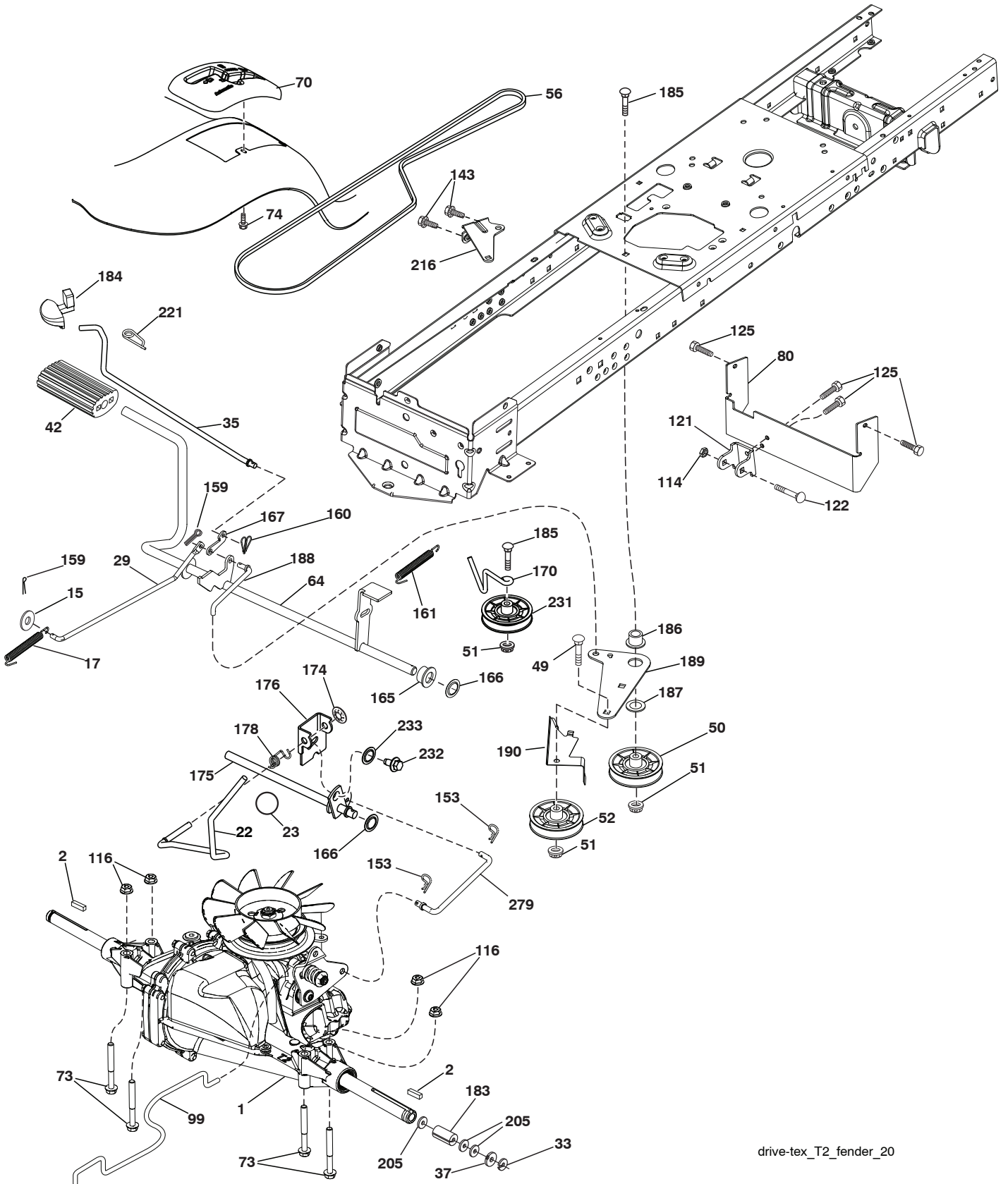

drive-tex_T2_fender_20

TRACTOR - - MODEL NUMBER M13577H (96041021200), PRODUCT NO. 960 41 02-12 DRIVE

KEY NO.	PART NO.	DESCRIPTION	KEY NO.	PART NO.	DESCRIPTION
1	---	Transaxle, Hydro Gear T2-BABC-1X1A-1GX1 (Order parts from transaxle manufacturer.)	153	532 12 47-88	Retainer Spring 1"
2	532 12 35-83	Key Square	159	876 02 04-12	Pin Cotter 1/8 x 3/4
15	819 13 13-16	Washer 13/32 x 13/16 x 16 Ga.	160	532 16 94-84	Retainer Clip
17	532 19 72-96	Spring, Brake	161	532 10 57-09	Spring, Return, Clutch
22	532 19 76-60	Rod Shift	165	532 19 62-12	Bushing
23	532 12 12-74	Knob	166	532 42 91-64	Nut Push .625
29	532 42 32-39	Rod, Brake	167	532 40 52-57	Latch Brake Parking
33	812 00 00-01	Ring E	170	532 41 34-30	Keeper Belt Centerspan
35	532 19 77-22	Rod, Brake, Park	174	532 19 72-89	Nut Push
37	532 12 17-49	Washer 25/32 x 1-1/4 x 16 Ga.	175	532 40 85-39	Shaft Asm Shift
42	532 12 48-72	Cover, Foot Pedal	176	532 19 62-14	Arm Clevis Rod Shift
49	872 11 06-14	Bolt	178	532 19 74-56	Spring Shift
50	532 19 43-27	Pulley Idler Flat	183	532 15 69-72	Spacer Axle
51	873 90 06-00	Lock Nut 3/8-16	184	532 41 12-89	Handle Parking Brake
52	532 19 43-26	Idler V-Groove	185	872 11 06-22	Bolt
56	532 12 59-07	V-Belt, Drive	186	532 19 43-21	Spacer Retainer
64	532 19 62-00	Shaft Asm. Pedal Brake Control	187	819 13 32-10	Washer
70	532 41 13-29	Console	188	532 19 43-23	Link Clutch Ground Drive
73	874 49 05-44	Bolt Hex 5/16-18 Gr. 5	189	532 19 43-17	Bellcrank Ground Drive
74	532 14 24-32	Screw 1/4 x 1/2	190	532 19 43-18	Keeper Bellcrank Ground Drive
80	581 55 07-01	Strap Torque	205	532 12 17-48	Washer 25/32 x 1-5/8 x 16 Ga.
99	532 40 84-18	Rod Spring Bypass	216	532 19 61-31	Bracket Pulley Idler
114	873 80 05-00	Nut Lock 5/16-18 unc	221	532 40 31-87	Retainer Spring Clip Handle
116	873 90 05-00	Nut Lock Hex Flange 5/16-18	231	532 40 72-87	Idler V-Groove 1.688" Offset
121	532 17 56-11	Bracket Strap Torque	232	874 78 07-16	Bolt 7/16-14 x 1 Gr. 5
122	872 01 05-20	Bolt 5/16-18 x 2.50	233	532 40 52-96	Washer Serrated
125	817 00 05-12	Screw 5/16-18 x 3/4	279	532 42 41-55	Link Shift
143	817 49 05-08	Screw THDROL 5/16-18 x 1/2			

NOTE: All component dimensions given in U.S. inches
1 inch = 25.4 mm

**TRACTOR - - MODEL NUMBER M13577H (96041021200), PRODUCT NO. 960 41 02-12
ENGINE**

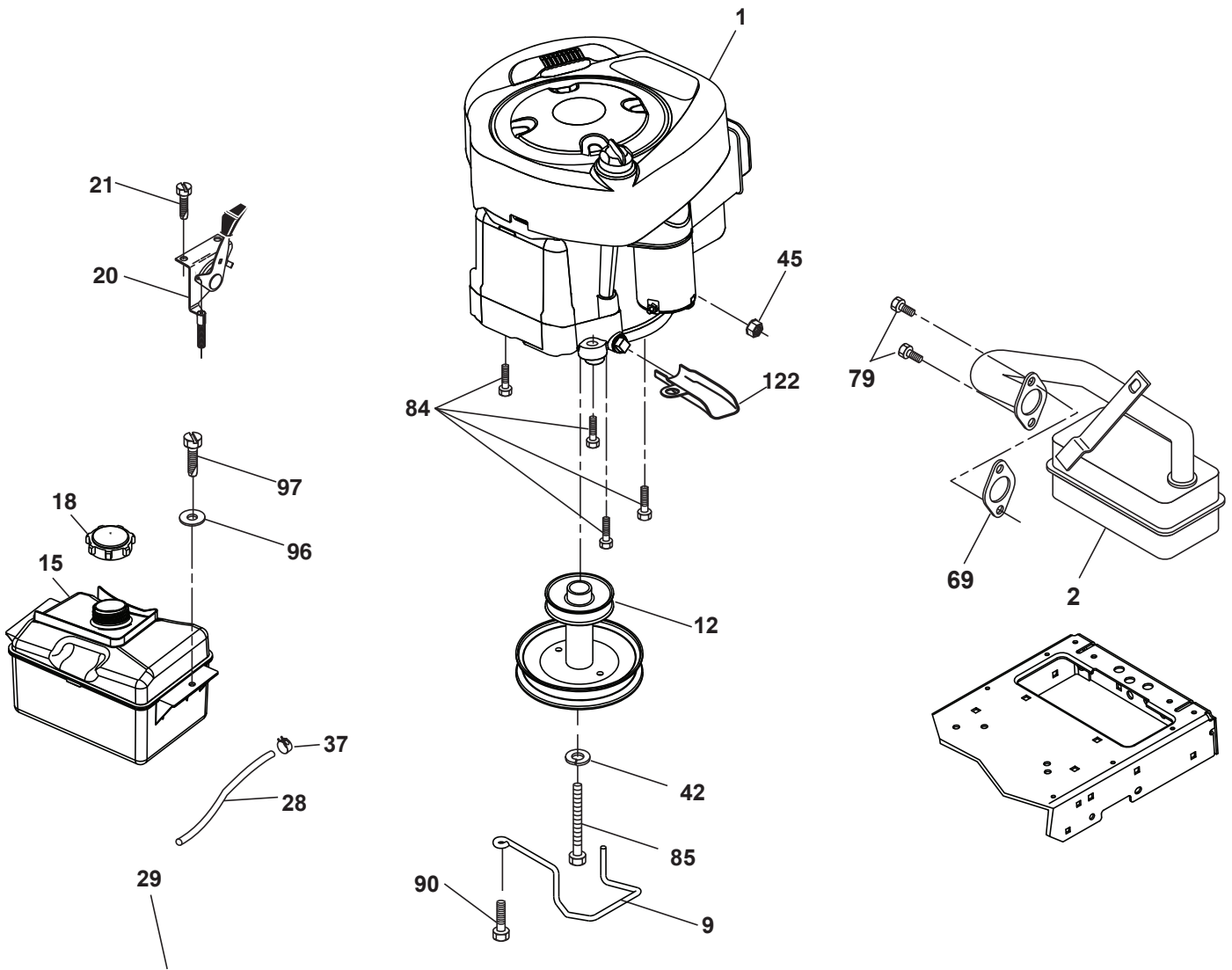

OPTIONAL EQUIPMENT
Spark Arrester

engine-tex_BS_24

TRACTOR - - MODEL NUMBER M13577H (96041021200), PRODUCT NO. 960 41 02-12 ENGINE

KEY NO.	PART NO.	DESCRIPTION
1	---	Engine Briggs Model No. 21B807-1453-B1 (Order parts from engine manufacturer.)
2	532 17 97-58	Muffler
9	532 19 43-19	Keeper Belt Engine
12	532 14 01-86	Pulley Engine
15	532 40 75-45	Tank Fuel
18	532 43 02-20	Cap Fuel
20	532 41 17-24	Control Throttle
21	532 41 63-58	Screw #10 x 0.750 BOS Thread
28	532 13 70-40	Fuel Line
29	532 13 71-80	Spark Arrester Kit
37	532 12 34-87	Clamp Hose
42	810 04 07-00	Washer Lock 7/16
45	873 51 04-00	Nut Keps Hex 1/4-20 unc
69	532 16 52-91	Gasket
79	532 19 23-34	Screw 5/16-18 x 3/4
84	817 06 06-20	Screw 3/8-16 x 1/4
85	532 17 39-37	Bolt Hex 7/16-20 x 4 Gr. 5
90	817 00 06-16	Screw 3/8-16 x 1
96	819 09 14-16	Washer 9/32 x 7/8 x 16 Ga.
97	817 67 04-12	Screw 1/4-20 x 3/4
122	532 42 19-22	Extension Drain Oil

NOTE: All component dimensions given in U.S. inches
1 inch = 25.4 mm

Engine Power Rating Information

The gross power rating for individual gas engine models is labeled in accordance with SAE (Society of Automotive Engineers) code J1940 (Small Engine Power & Torque Rating Procedure), and rating performance has been obtained and corrected in accordance with SAE J1995 (Revision 2002-05). Torque values are derived at 3060 RPM; horsepower values are derived at 3600 RPM. Actual gross engine power will be lower and is affected by, among other things, ambient operating conditions and engine-to-engine variability. Given both the wide array of products on which engines are placed and the variety of environmental issues applicable to operating the equipment, the gas engine will not develop the rated gross power when used in a given piece of power equipment (actual "on-site" or net power). This difference is due to a variety of factors including, but not limited to, accessories (air cleaner, exhaust, charging, cooling, carburetor, fuel pump, etc.), application limitations, ambient operating conditions (temperature, humidity, altitude), and engine-to-engine variability. Due to manufacturing and capacity limitations, Briggs & Stratton may substitute an engine of higher rated power for this Series engine.

**TRACTOR -- MODEL NUMBER M13577H (96041021200), PRODUCT NO. 960 41 02-12
STEERING ASSEMBLY**

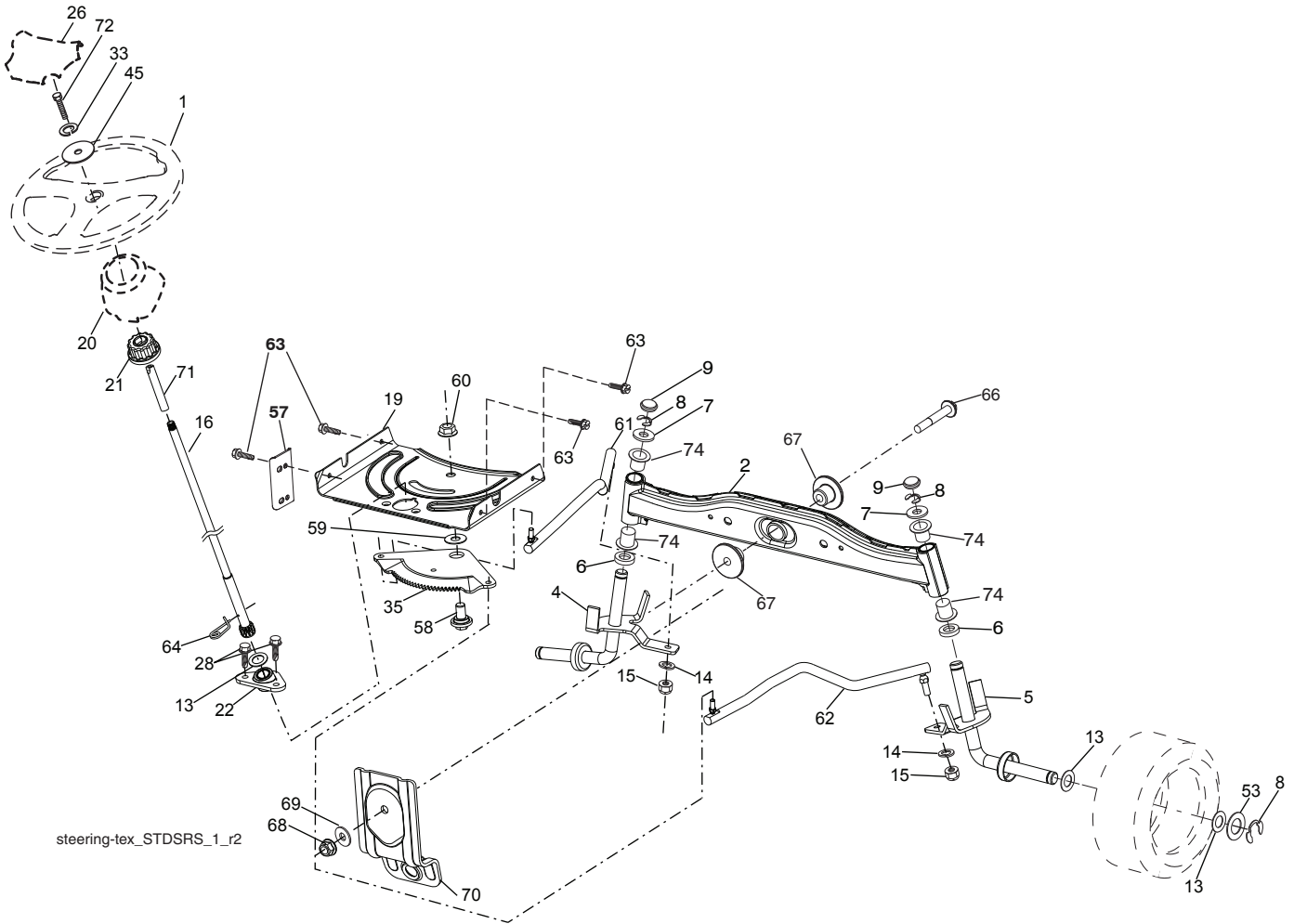

**TRACTOR - - MODEL NUMBER M13577H (96041021200), PRODUCT NO. 960 41 02-12
STEERING ASSEMBLY**

KEY NO.	PART NO.	DESCRIPTION
1	532 42 45-43	Wheel, Steering
2	532 41 81-68	Axle Asm., Front
4	532 41 68-45	Spindle Asm., LH
5	532 41 68-46	Spindle Asm., RH
6	532 12 49-31	Washer Thrust
7	532 12 17-48	Washer 25/32 x 1-5/8 x 16 Ga.
8	812 00 00-29	Ring, Klip #T5304-75
9	532 12 12-32	Cap, Spindle
13	532 12 17-49	Washer 25/32 x 1-1/4 x 16 Ga.
14	810 04 06-00	Washer, Lock Hvy Hlcl Spr 3/8
15	873 54 06-00	Nut, Crown Lock 3/8-24 unf
16	532 42 93-74	Shaft Steering
19	532 19 47-29	Plate Steering
20	532 41 12-91	Boot, Steering
21	532 18 67-37	Adapter, Wheel Steering
22	532 42 05-37	Bushing, Support Lower
26	532 42 41-47	Insert, Wheel Steering
28	817 00 06-12	Screw 3/8-16 x 3/4
33	810 04 05-00	Washer Lock 5/16
35	532 19 47-32	Gear, Sector Plate
45	819 11 38-12	Washer 11/32 x 3/8 x 12 Ga.
53	532 18 89-67	Washer Hardened .793 x 1.637 x .060
57	532 40 74-65	Bracket Upstop
58	532 19 47-47	Bolt Shoulder Sector Pivot CFM
59	532 19 47-48	Washer Thrust Sector Steering
60	873 97 10-00	Nut Flange Lock 5/8-11
61	532 19 47-40	Draglink, LH
62	532 19 47-41	Draglink, RH
63	817 00 05-12	Screw 5/16-18 x 3/4
64	532 19 98-49	Retainer Clip Spring Steering
66	871 02 07-48	Bolt Hex Fghd 7/16-14 x 3 Serr
67	532 19 47-37	Bushing PM Front Axle
68	873 90 07-00	Nut Lock Flange 7/16-14 Gr. 5
69	532 19 91-62	Washer 1.5 x .505 x .118
70	532 41 70-65	Bracket Deck Susp. Front
71	532 19 07-52	Shaft Extension Steering
72	532 42 89-82	Bolt Fin Hex 5/16-18 x 4 w/Patch
74	532 12 49-37	Bearing

NOTE: All component dimensions given in U.S. inches
1 inch = 25.4 mm

**TRACTOR - - MODEL NUMBER M13577H (96041021200), PRODUCT NO. 960 41 02-12
MOWER DECK**

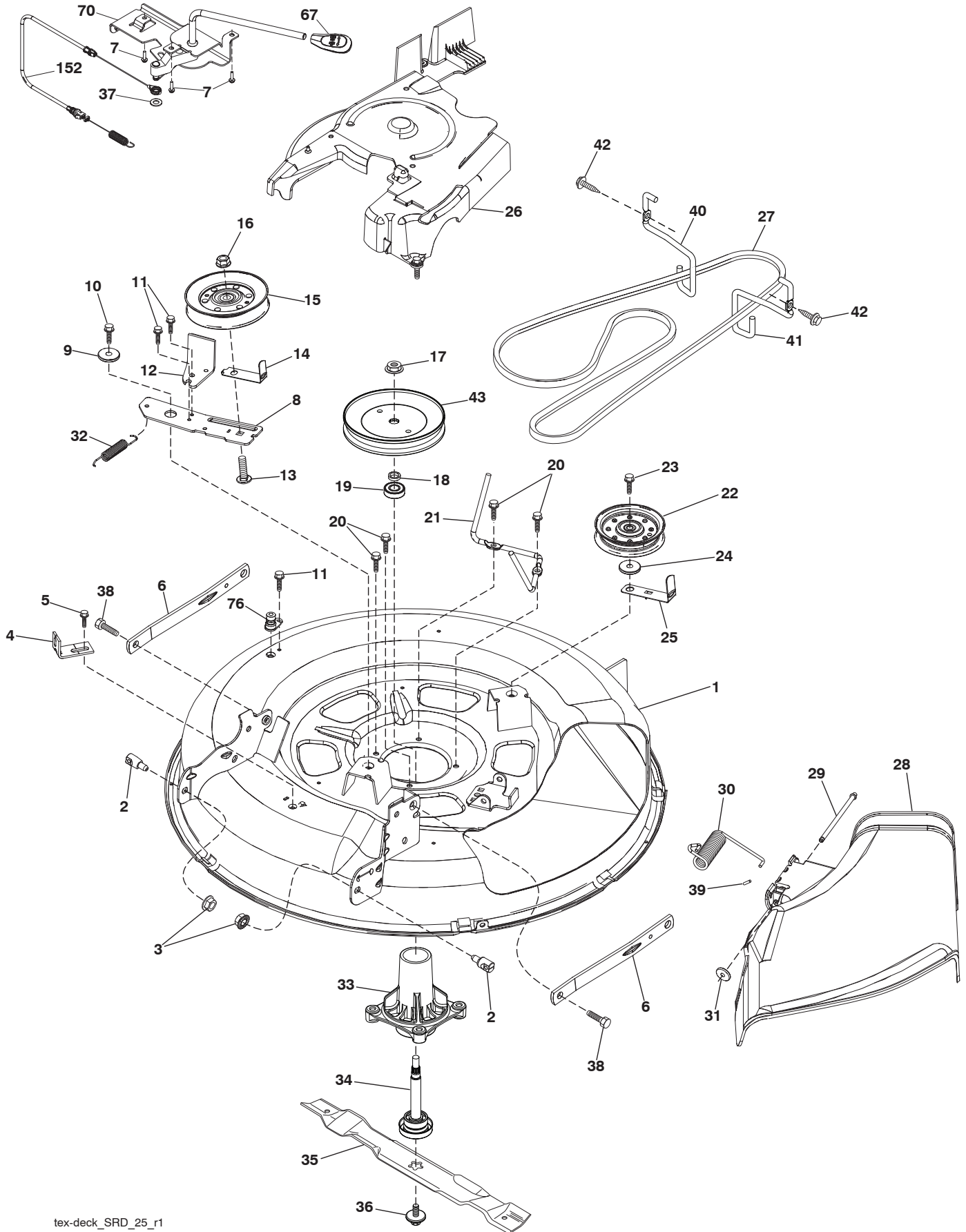

tex-deck_SRD_25_r1

**TRACTOR - - MODEL NUMBER M13577H (96041021200), PRODUCT NO. 960 41 02-12
MOWER DECK**

KEY NO.	PART NO.	DESCRIPTION	KEY NO.	PART NO.	DESCRIPTION
1	532 41 92-72	Deck Weldment 30" Srd	32	532 40 18-72	Spring Return Deck 38/46"
2	532 19 51-61	Stud Fastner w/'D'anti-Rotatio	33	532 18 72-81	Housing Mandrel 4pt Service
3	873 90 05-00	Nut Lock Hex Flange 5/16-18	34	532 19 28-72	Shaft Asm Mndrl N/Greaseable 38
4	532 41 76-45	Bracket Clutch Cable	35	532 41 92-73	Blade Mower Hp/Mulch Srd
5	817 00 05-10	Bolt 5/16-18	36	532 19 30-03	Bolt/Washer Asm 7/16-20 unf
6	532 41 88-63	Arm Susp Mower Rear Srd	37	819 13 13-16	Washer 13/32 x 13/16 x 16 Ga.
7	532 41 63-58	Screw #10 x 0.750 BOS Thread	38	532 19 65-39	Bolt Shoulder
8	532 42 02-52	Arm Idler 30"Srd	39	532 10 53-04	Cap Sleeve
9	532 19 90-92	Spacer Retainer	40	532 41 92-70	Keeper Belt Engine LH
10	817 00 06-16	Screw 3/8-16 x 1 Smgml Tap/R Blk	41	532 41 92-65	Keeper Belt Engine RH
11	532 13 77-29	Screw Thd Roll 1/4-20 x 5/8	42	817 00 06-12	ScrewHexwsh THDR3/8-16x3/4BL
12	532 19 94-70	Arm Brake Mower 38" RH Tex	43	532 41 68-77	Pulley Mandrel 6 5 Pd 30"
13	872 11 06-12	Bolt Carr Sh 3/8-16 x 1-1/2 Gr. 5	67	532 40 97-92	Handle clutch cable
14	532 15 60-85	Keeper Belt Idler	70	532 19 83-32	Clutch Asm. Manual
15	532 14 67-63	Pulley Ikler V-Groove Dim 4.25	76	532 41 55-98	Port Washer
16	873 90 06-00	Nut Lock FIG 3/8 - 16 unc	152	532 43 51-11	Manual Clutch Cable
17	532 40 02-34	Nut Flange Lock Top	--	532 19 28-70	Mandrel Assembly (Includes Housing Shaft Assembly, And Bearing Only - Pulley/Nut/Washer And Blade Bolt/Washers Not Included)
18	532 18 76-90	Washer Spacer Mandrel	--	532 43 23-46	Replacement Mower Complete
19	532 11 04-85	Bearing Ball Mandrel			
20	532 17 39-84	Screw Thd Roll Dod Pt Hex			
21	532 41 69-10	Keeper Belt Mandrel 30"			
22	532 19 31-98	Pulley Idler Flat Unplated			
23	817 49 06-28	Screw Thdrol 3/8-16 x 1-3/4			
24	819 13 20-12	Washer 13/32 x 1-1/4 x 12 Ga.			
25	532 42 02-53	Keeper Belt 30"Srd			
26	532 43 03-13	Cover Mandrel Mwr 30" Black			
27	532 41 92-71	V-Belt Drive			
28	532 41 73-44	Shield Asm Deflect Mwr 30s Blk			
29	532 42 08-95	Pin Hinge 30			
30	532 19 70-26	Spring Torsion Dfl 38/42/46 Gr.			
31	532 11 04-52	Nut Push Phos & Oil			

NOTE: All component dimensions given in U.S. inches
1 inch = 25.4 mm

**TRACTOR -- MODEL NUMBER M13577H (96041021200), PRODUCT NO. 960 41 02-12
MOWER LIFT**

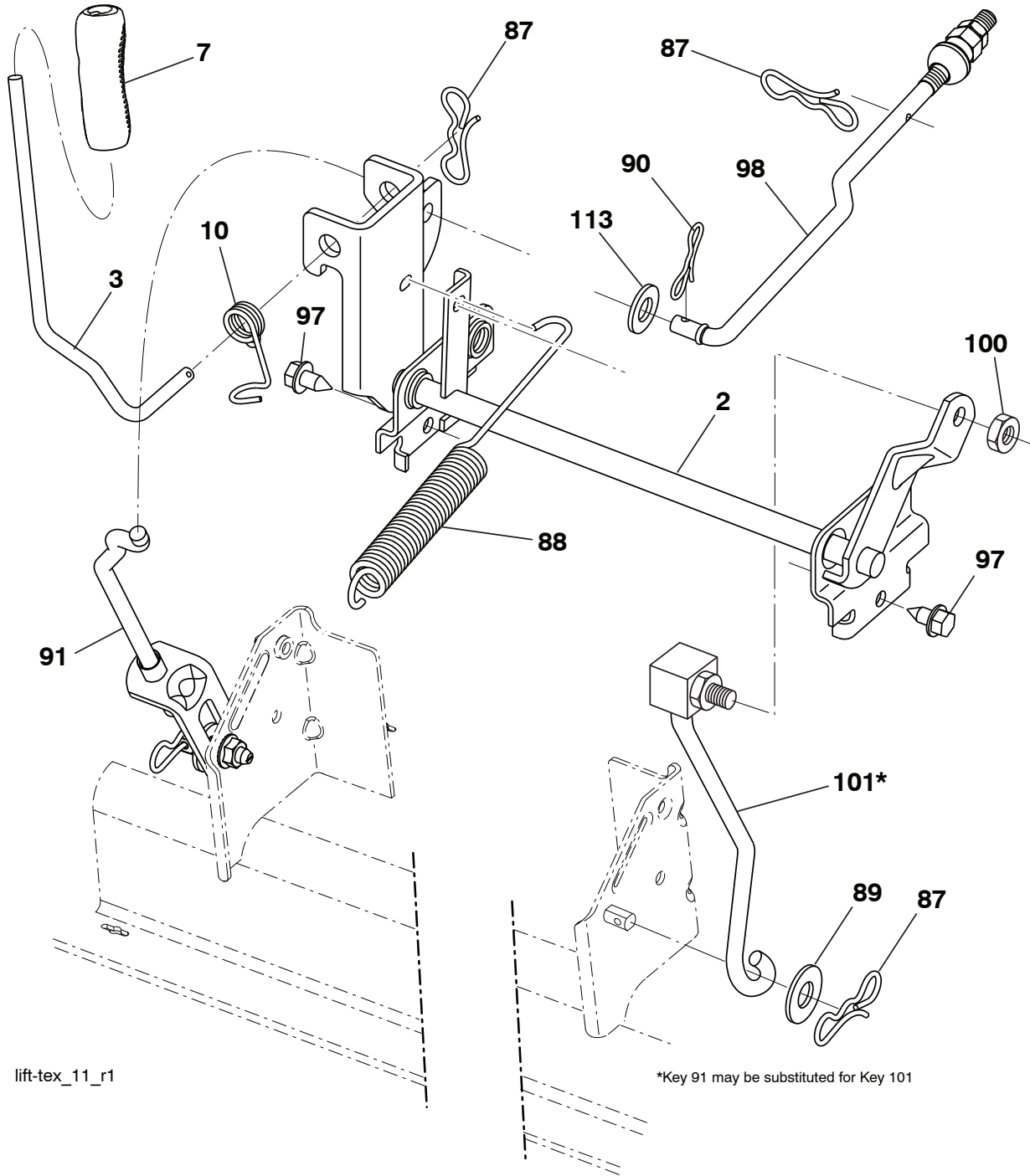

lift-tex_11_r1

*Key 91 may be substituted for Key 101

KEY NO.	PART NO.	DESCRIPTION
2	532 42 20-27	Shaft Asm. Cross, Lift
3	532 19 52-31	Lever Asm., Lift RH
7	532 41 17-42	Grip, Lever
10	532 19 63-14	Spring Torsion
87	532 19 42-09	Pin Cotter 7/16 Bow Tie Lock
88	532 41 07-10	Spring Lift Assist
89	819 19 19-12	Washer Clear Zinc
90	532 19 42-08	Pin Cotter 5/16 Bow Tie Lock
91	532 19 51-81	Link Asm Lift LH Rear

KEY NO.	PART NO.	DESCRIPTION
97	817 00 06-12	Screw Hex Wsh. THDR 3/8-16x3/4
98	532 19 52-64	Link Lift Susp. Front Mower
100	873 93 06-00	Nut Centerlock 3/8-16 unc
101	532 40 70-03	Link Asm Lift FXD
113	819 17 19-12	Washer Clear

NOTE: All component dimensions given in U.S. inches
1 inch = 25.4 mm

**TRACTOR - - MODEL NUMBER M13577H (96041021200), PRODUCT NO. 960 41 02-12
SEAT ASSEMBLY**

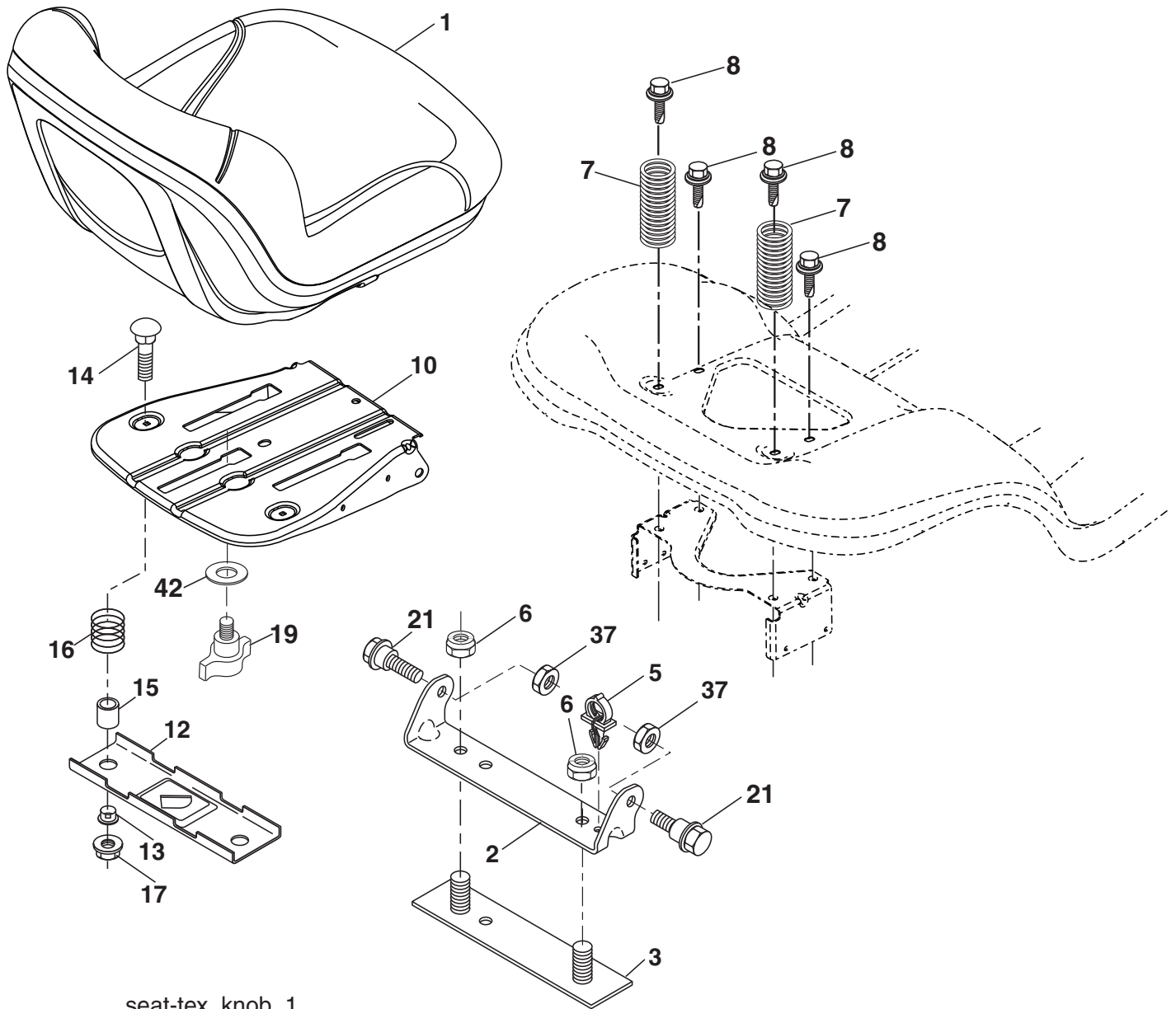

seat-tex_knob_1

KEY NO.	PART NO.	DESCRIPTION
1	532 19 75-11	Seat
2	532 18 01-66	Bracket Pivot Fender
3	532 14 06-75	Strap, Asm Fender
5	532 14 50-06	Clip Push-In Hinged
6	873 80 06-00	Nut, Lock w/Ins. 3/8-16 unc
7	532 12 41-81	Spring, Seat Cprsn
8	532 17 18-77	Bolt 5/16-18 unc x 3/4 w/Sems
10	532 44 18-05	Pan, Seat
12	532 19 93-70	Bracket Seat Mounting
13	532 12 12-48	Bushing Snap
14	872 05 04-12	Bolt RDHD Sht NK 1/4-20 x 1-1/2

KEY NO.	PART NO.	DESCRIPTION
15	532 13 43-00	Spacer Split .28 x .96 Yel Zinc
16	532 12 37-40	Spring
17	532 12 39-76	Nut Lock 1/4 LGE FLG Gr. Zinc
19	532 19 93-72	Knob Seat Adj. 3/18-16" Tex
21	532 17 18-52	Bolt, Shoulder 5/16-18
37	873 80 05-00	Nut, Lock 5/16-18 unc
42	532 19 93-71	Washer Cup Seat Tex LT

NOTE: All component dimensions given in U.S. inches
1 inch = 25.4 mm

