

ILLUSTRATED PARTS LIST

MODEL NO. 96041009102

CUSTOMER CATALOG NO. M13597

PRODUCT NO. 960 41 00-91

**TRACTOR - - MODEL NO. M13597 (96041009102), PRODUCT NO. 960 41 00-91
DECALS 27**

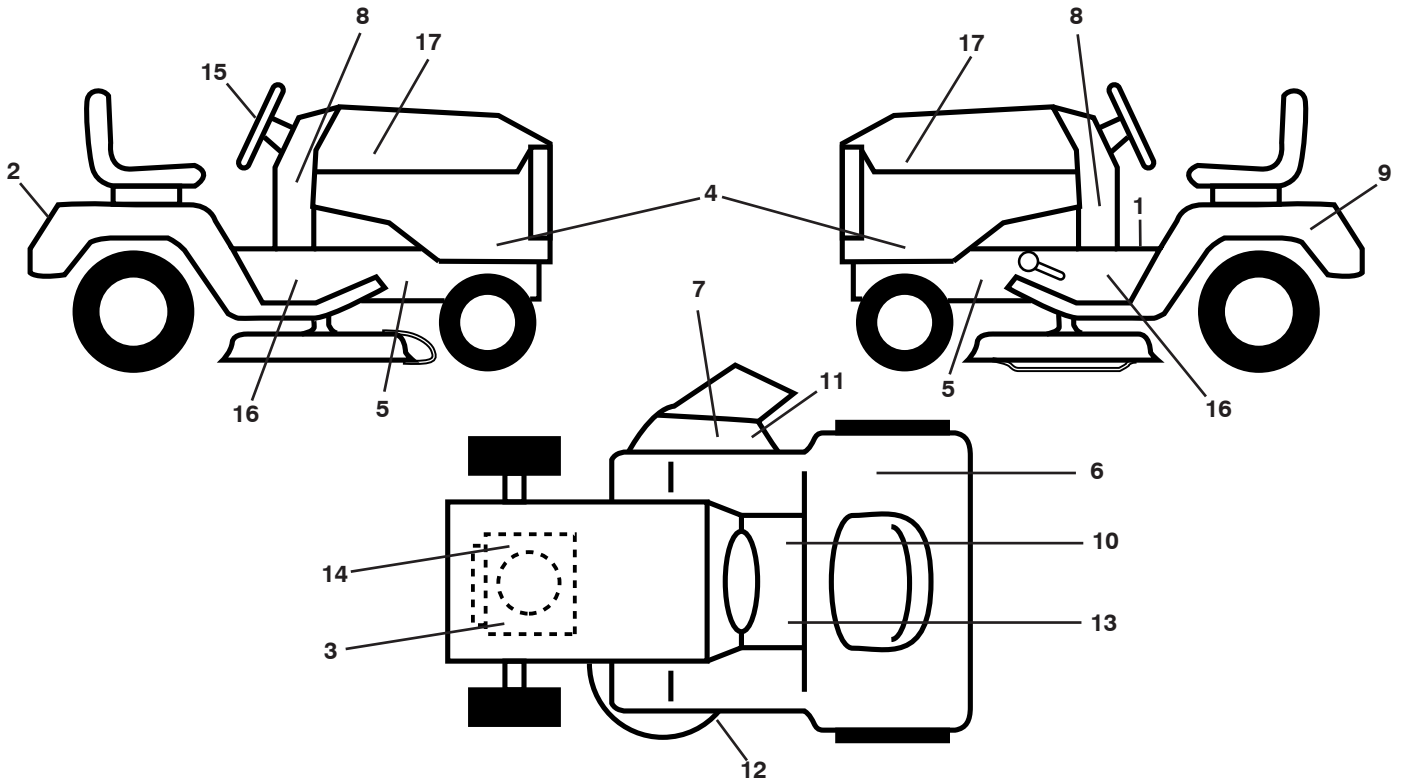

KEY NO.	PART NO.	DESCRIPTION
1	532 40 03-89	Decal, Operators
2	532 40 82-60	Decal, Fender
3	532 19 68-41	Decal, Warning Eng. Symbols
4	532 43 35-70	Decal, Hood Panel
5	532 15 97-36	Decal, Chassis Hot Muffler
6	532 18 04-32	Decal, Fender 100 DB/CE
7	532 18 21-66	Decal, Cutfinger CE
8	532 18 56-51	Decal, Chas. Turbo Collection
9	532 14 50-05	Decal, Battery Dnge/Poi
10	532 14 08-37	Decal, Saddle Brake Parking
11	532 19 63-57	Decal, Warning

KEY NO.	PART NO.	DESCRIPTION
12	532 19 43-02	Decal, Mower V-Belt Schematic
13	532 15 97-37	Decal, Brake/Clutch Symbol
14	532 43 20-13	Decal, BS HP
15	532 42 42-36	Decal, Wheel Str.
16	532 40 11-46	Decal, Warning Service/Fire
17	532 43 11-71	Decal, Hood
--	532 16 25-98	Decal, Drawbar
--	532 40 95-05	Pad, Footrest, LH
--	532 41 12-73	Pad, Footrest, RH
--	532 43 42-91	Manual Oper. Euro

WHEELS AND TIRES

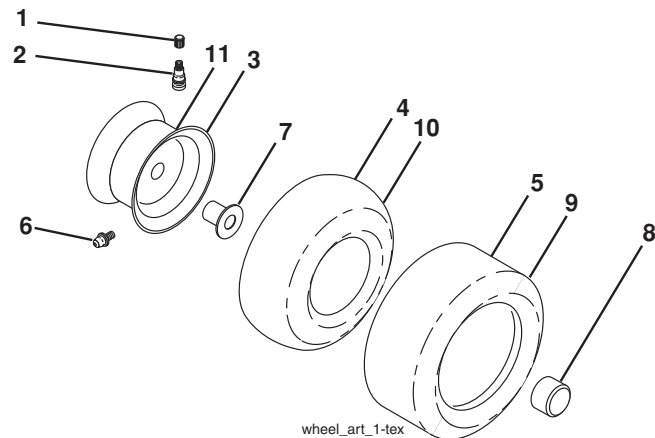

KEY NO.	PART NO.	DESCRIPTION
1	532 05 91-92	Cap Valve Tire
2	532 06 51-39	Stem Valve
3	532 12 51-21	Rim Asm 6" Front
4	532 05 99-04	Tube Front (Service Item Only)
5	532 10 62-22	Tire F T 15 x 6 0 - 6
6	532 12 49-57	Fitting Grease (Front Wheel Only)
7	532 12 49-59	Bearing Flange (Front Wheel Only)
8	532 17 50-39	Cap Axle Blk 1 50 x 1 00
9	532 12 46-35	Tire R 18 x 8.5-8
10	532 12 49-26	Tube Rear (Service Item Only)
11	532 12 51-22	Rim Asm 8" Rear
--	532 14 43-34	Sealant, Tire (10 oz. Tube)

NOTE: All component dimensions given in U.S. inches
1 inch = 25.4 mm

TRACTOR - - MODEL NO. M13597 (96041009102), PRODUCT NO. 960 41 00-91 SCHEMATIC 38

SCH11

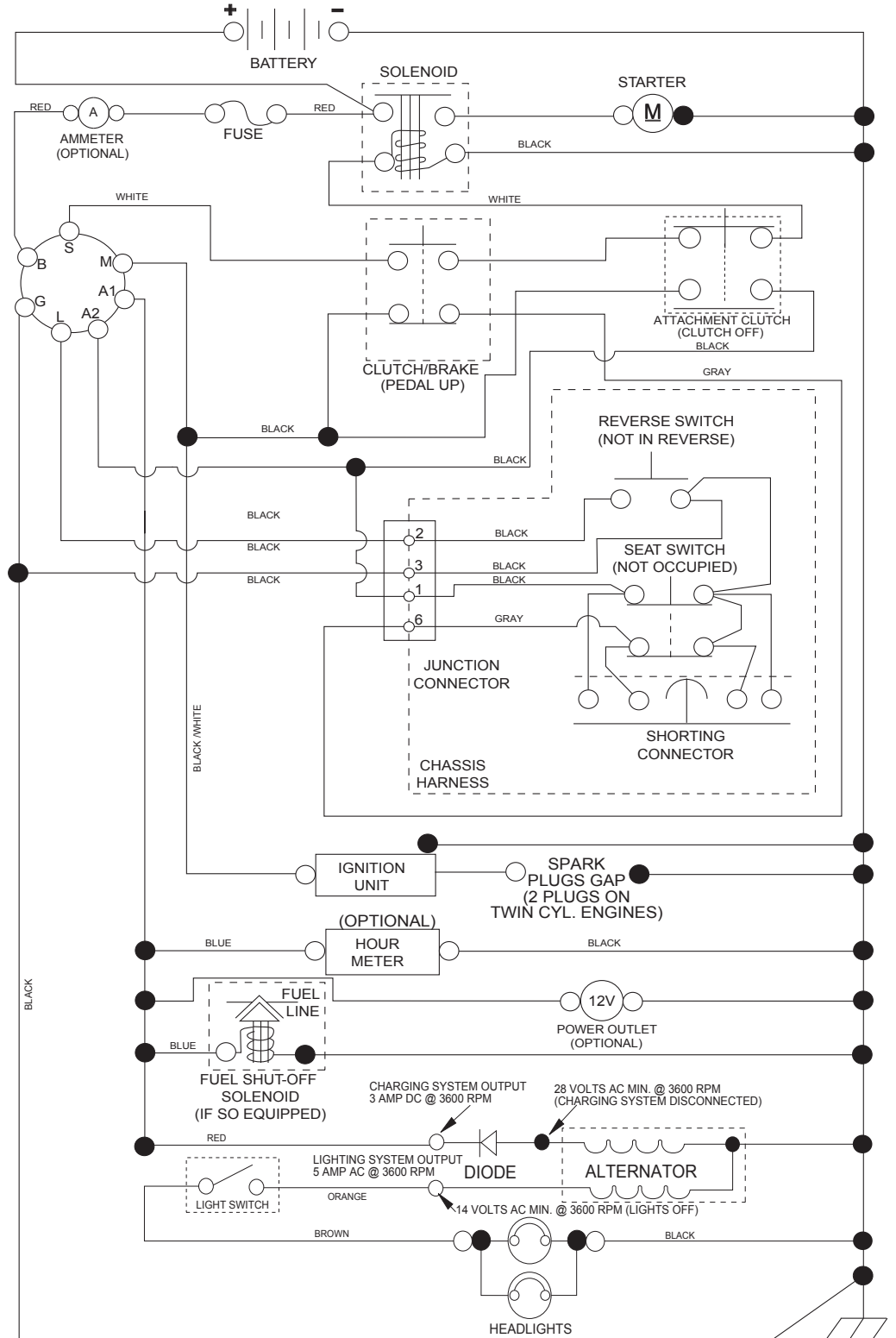

NOTE
YOUR TRACTOR IS EQUIPPED WITH A SPECIAL ALTERNATOR SYSTEM. THE LIGHTS ARE NOT CONNECTED TO THE BATTERY, BUT HAVE THEIR OWN ELECTRICAL SOURCE. BECAUSE OF THIS, THE BRIGHTNESS OF THE LIGHTS WILL CHANGE WITH ENGINE SPEED. AT IDLE THE LIGHTS WILL DIM. AS THE ENGINE IS SPEEDED UP, THE LIGHTS WILL BECOME THEIR BRIGHTEST.

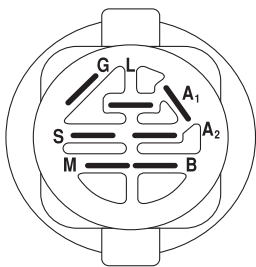

IGNITION SWITCH

POSITION	CIRCUIT	"MAKE"
OFF	M+G+A1	
RUN/OVERRIDE	B+A1	
RUN	B+A1	L+A2
START	B + S + A1	

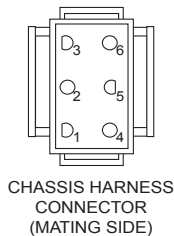

CHASSIS HARNESS CONNECTOR (MATING SIDE)

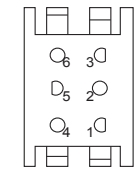

DASH HARNESS CONNECTOR (MATING SIDE)

WIRING INSULATED CLIPS
NOTE: IF WIRING INSULATED CLIPS WERE REMOVED FOR SERVICING OF UNIT, THEY SHOULD BE RE-INSTALLED TO PROPERLY SECURE YOUR WIRING.

NON-REMOVABLE CONNECTIONS

REMOVABLE CONNECTIONS

TRACTOR - - MODEL NO. M13597 (96041009102), PRODUCT NO. 960 41 00-91
ELECTRICAL **32**

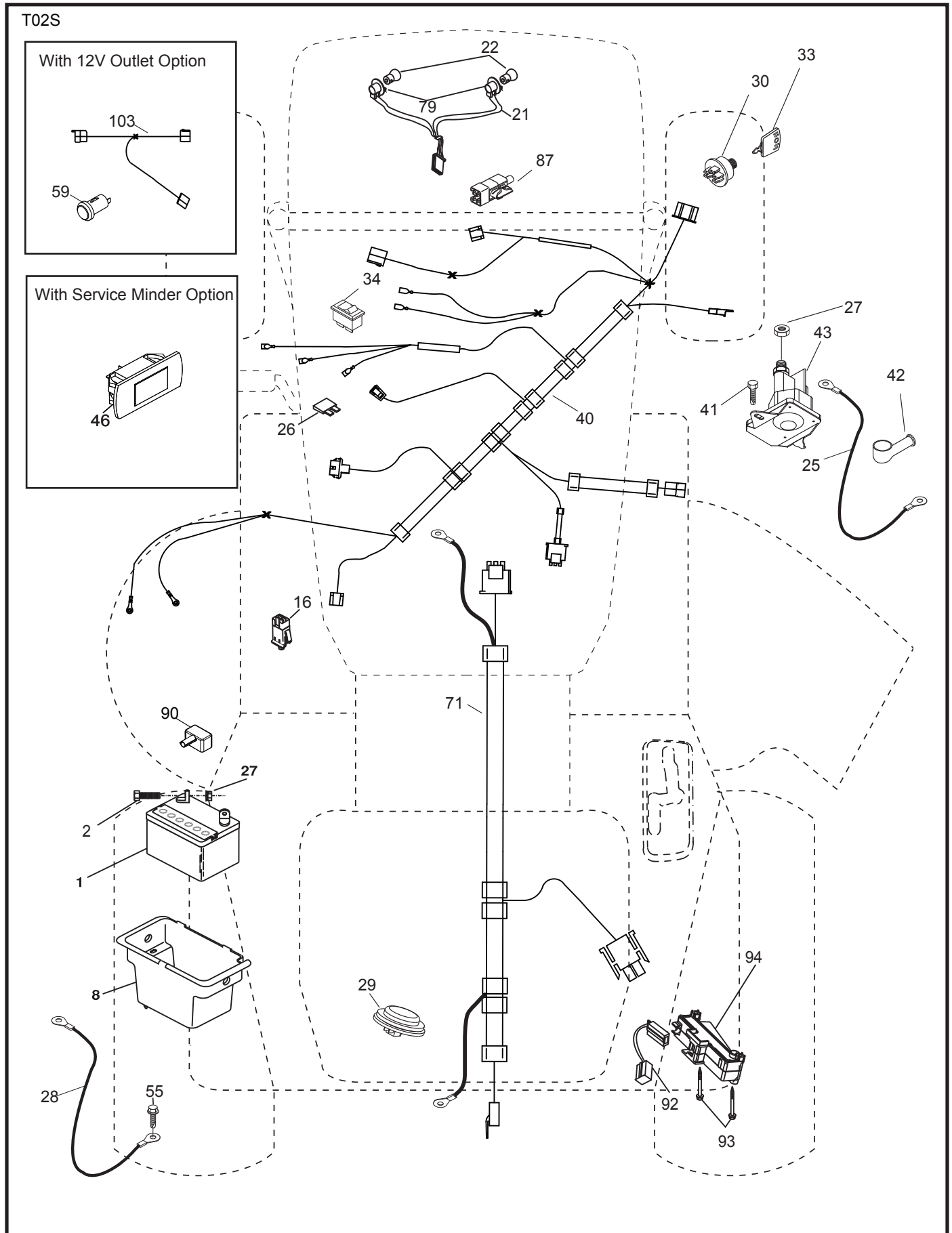

**TRACTOR - - MODEL NO. M13597 (96041009102), PRODUCT NO. 960 41 00-91
ELECTRICAL 32**

KEY NO.	PART NO.	DESCRIPTION
1	532 16 34-65	Battery
2	874 76 04-12	Bolt Hex Head 1/4-20 x 3/4
8	532 19 32-28	Box Battery
16	532 17 61-38	Switch Interlock Push-In
21	532 18 37-59	Harness Socket Light w/4152J
22	532 00 41-52	Bulb Light
25	532 41 28-94	Cable Starter
26	532 17 51-58	Fuse
27	873 51 04-00	Nut Keps Hex 1/4-20 unc
28	532 19 88-85	Cable,Ground
29	532 40 15-45	Switch, Seat
30	532 19 33-50	Switch, Ign
33	532 41 19-35	Key/Chain
34	532 11 07-12	Switch Light/Reset
40	532 40 10-98	Harness Ign. Dash
41	817 72 04-08	Screw Thd Cut 1/4-20 x 1/2
42	532 13 15-63	Cover, Terminal
43	532 19 25-07	Solenoid
55	817 06 05-12	Screw Thdrol 5/16-18 x 3/4 TYTT
71	532 40 04-49	Harness Ign.
79	532 17 52-42	Socket Asm
87	532 19 78-02	Switch Interlock Clutch Cbl
90	532 40 07-25	Cover Terminal
92	532 19 66-15	Harness Pigtail Reverse Switch
93	532 19 25-40	Screw Plastite 10-14 x 2.0
94	532 19 18-34	Module Reverse ROS

NOTE: All component dimensions given in U.S. inches
1 inch = 25.4 mm

TRACTOR - - MODEL NO. M13597 (96041009102), PRODUCT NO. 960 41 00-91
 CHASSIS AND ENCLOSURES **39**

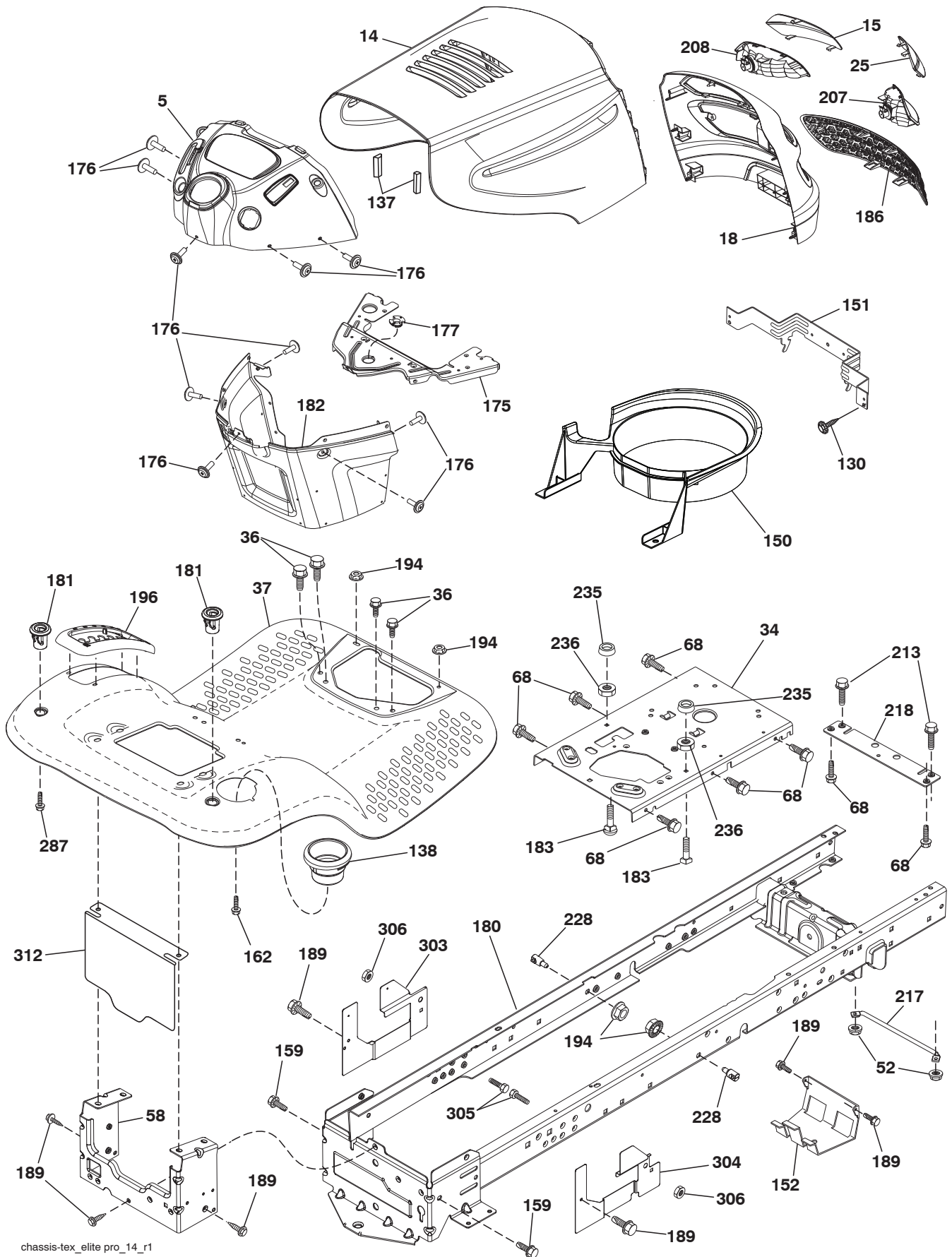

chassis-tex_elite_pro_14_r1

**TRACTOR - - MODEL NO. M13597 (96041009102), PRODUCT NO. 960 41 00-91
CHASSIS AND ENCLOSURES 39**

KEY NO.	PART NO.	DESCRIPTION
5	532 41 12-79	Dash
14	532 18 65-80	Hood
15	532 18 97-54	Lens Grille LH
18	532 18 97-48	Grille
25	532 18 97-55	Lens Grille RH
34	532 19 61-25	Plate Engine
36	817 06 05-12	Screw 5/16-18 x 3/4
37	532 42 09-86	Fender
52	873 68 05-00	Nut Crown Lock 5/16
58	532 41 22-80	Drawbar, Upper
68	817 49 05-08	Screw THDROL 5/16-18 x 1/2
130	532 41 63-58	Screw 10 x .750 BOS Thread
137	532 18 49-21	Bumper Hood
138	532 40 97-30	Cupholder
150	532 18 44-61	Air Duct
151	532 40 78-07	Bracket Pivot
152	532 19 95-35	Shield Browning
159	817 00 06-12	Screw Hexwsh Thdr 3/8-16 x 3/4 BL
162	532 14 24-32	Screw Hex Wsh. Hi-Lo 1/4 x 1 unc
175	532 19 32-43	Crossmember
176	532 40 07-76	Screw 10-24 x 5/8
177	532 19 52-28	Bushing Steering
180	532 41 50-63	Chassis
181	532 40 47-96	Bushing MNT Fender
182	532 19 30-57	Dash Lower
183	874 52 05-20	Bolt 5/16-18 x 1-1/4
186	532 18 97-53	Insert Grille
189	817 00 05-12	Screw 5/16-18 x 3/4
194	873 90 05-00	Nut Lock Hex Flange 5/16-18
196	532 41 45-81	Console Deck Lift Asm.
207	532 18 38-33	Bezel Grille RH
208	532 18 38-32	Bezel Grille LH
213	874 76 05-12	Bolt 5/16-18 x 3/4
217	532 40 91-67	Rod Pivot Hood
218	532 19 63-95	X-Piece Hood Stop
228	532 19 51-61	Stud Fastener
235	532 40 61-29	Spacer Fender
236	873 93 05-00	Nut Lock 5/16-18 unc
287	817 60 04-06	Screw Hex Washhead 1/4-20 x 3/8
303	532 42 09-59	Shield Chassis French LH
304	532 42 15-09	Shield Chassis French RH
305	872 11 06-06	Bolt RDHD SQNK 3/8-16 x 3/4
306	873 90 06-00	Nut Lock Flg 3/8-16 unc
312	532 42 59-26	Shield Drawbar

NOTE: All component dimensions given in U.S. inches
1 inch = 25.4 mm

TRACTOR - - MODEL NO. M13597 (96041009102), PRODUCT NO. 960 41 00-91
DRIVE **40**

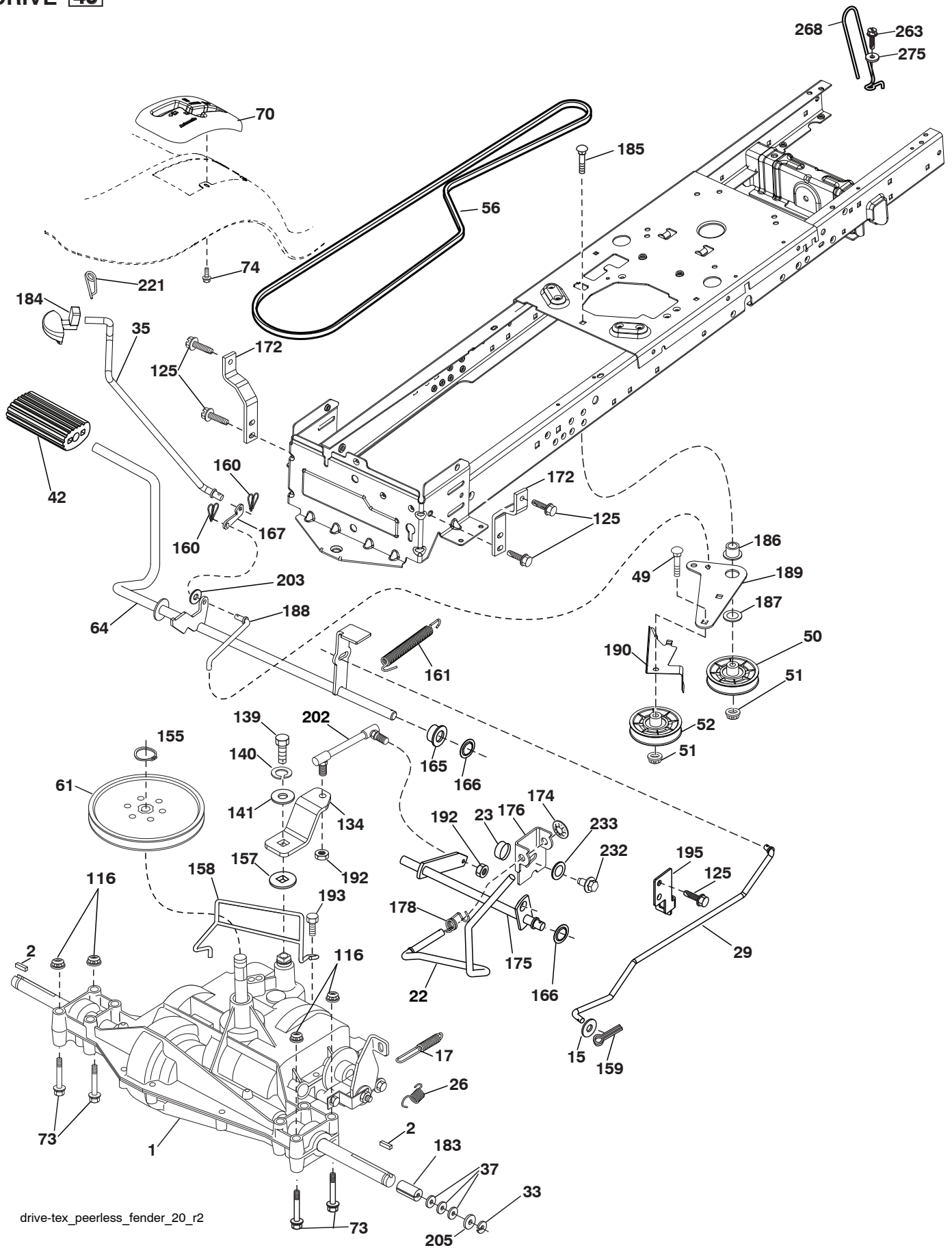

drive-tex_peerless_fender_20_r2

**TRACTOR - - MODEL NO. M13597 (96041009102), PRODUCT NO. 960 41 00-91
DRIVE 40**

KEY NO.	PART NO.	DESCRIPTION	KEY NO.	PART NO.	DESCRIPTION
1	-----	Transaxle, Peerless 206-565	165	532 19 62-12	Busing Shaft Brake Hand Control
2	532 12 35-83	Key Square	166	532 42 91-64	Nut Push .625
15	819 13 13-16	Washer 13/32 x 13/16 x 16 Ga.	167	532 40 52-57	Latch Brake Parking
17	532 19 72-97	Spring, Brake	172	532 19 76-57	Strap Torque LH
22	532 19 76-60	Rod Shift	174	532 19 72-89	Nut Push
23	532 17 16-74	Knob	175	532 19 78-58	Shaft Asm. Shift
26	532 19 74-55	Spring Brake Return	176	532 19 62-14	Arm Clevis Rod Shift
29	532 19 72-67	Rod, Brake	178	532 19 74-56	Spring Shift
33	812 00 00-01	Ring E	183	532 13 70-57	Spacer Axle
35	532 19 77-22	Rod, Brake, Park	184	532 41 12-89	Handle Parking Brake
37	532 12 17-49	Washer 25/32 x 1-1/4 x 16 Ga.	185	872 11 06-22	Bolt 3/8-16 unc x 2-3/4 Gr. 5
42	532 12 48-72	Cover, Foot Pedal	186	532 19 43-21	Spacer Retainer
49	872 11 06-14	Bolt	187	819 13 32-10	Washer
50	532 19 43-27	Pulley Idler Flat	188	532 19 43-23	Link Clutch Ground Drive
51	873 90 06-00	Lock Nut 3/8-16	189	532 19 43-17	Bellcrank Ground Drive
52	532 19 43-26	Idler V-Groove	190	532 19 43-18	Keeper Bellcrank Ground Drive
56	532 19 43-46	V-Belt, Drive	192	532 15 03-60	Nut Lock Center 1/4-28 Fnthd
61	532 12 36-66	Pulley Transaxle	193	817 06 05-12	Screw 5/16-18 x 3/4
64	532 19 62-00	Shaft Asm. Pedal Brake Control	195	532 19 73-32	Bracket Brake Rod
70	532 41 12-90	Console Shift	202	532 19 78-59	Link Transaxle
73	874 49 05-44	Bolt Hex Flghd 5/16-18 Gr. 5	203	819 11 11-16	Washer 11/32 x 11/16 x 16 Ga.
74	532 14 24-32	Screw Hex Wsh 1/4 x 1/2	205	532 12 17-48	Washer 25/32 x 1-5/8 16 Ga.
116	873 90 05-00	Nut Lock Hex Flange 5/16-18	221	532 40 31-87	Retainer Spring Clip Handle
125	817 00 05-12	Screw 5/16-18 x 3/4	232	874 78 07-16	Bolt Hex 7/16-14 x 1 Gr. 5
134	532 19 78-57	Asm Shift	233	532 40 52-96	Washer Serrated
139	874 55 04-12	Bolt 1/4-28 unf Gr. 8 w/Patch	263	817 00 06-12	Screw Hexwsh THDR 3/8-16 x 3/4
140	810 04 04-00	Washer Lock Hvy Helical 1/4	268	532 18 24-02	Guard Muffler
141	819 09 12-10	Washer 9/32 x 3/4 x 10 Ga.	275	819 13 16-14	Washer 13/32 x 1 x 14 Ga.
155	812 00 00-28	Ring Retainer			
157	532 10 57-01	Washer Plate Shift			
158	532 19 43-52	Belt Keeper			
159	876 02 04-12	Pin Cotter 1/8 x 3/4			
160	532 16 94-84	Retainer Clip			
161	532 10 57-09	Spring, Return, Clutch			

NOTE: All component dimensions given in U.S. inches
1 inch = 25.4 mm

TRACTOR - - MODEL NO. M13597 (96041009102), PRODUCT NO. 960 41 00-91
ENGINE **24**

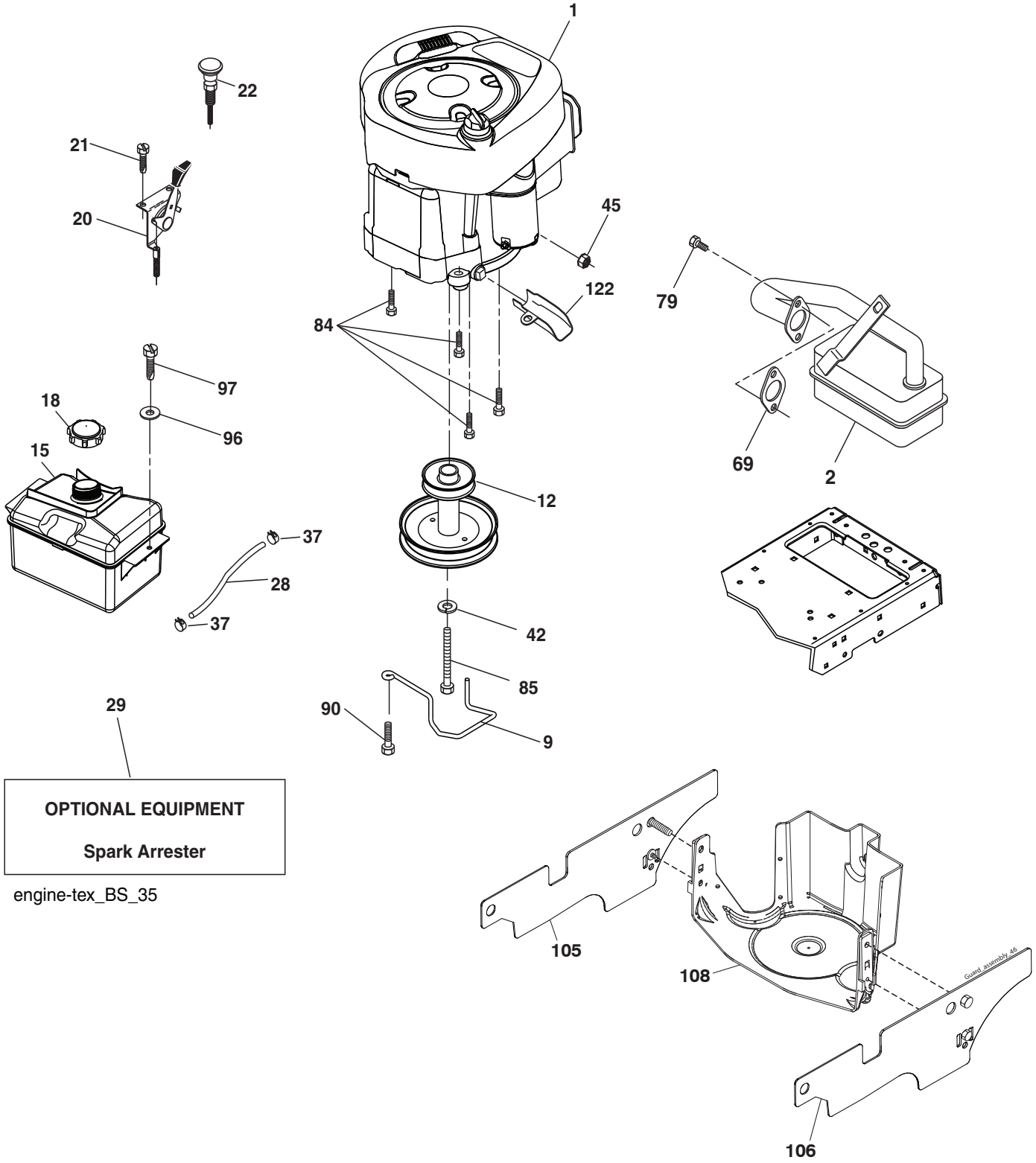

OPTIONAL EQUIPMENT
Spark Arrester

engine-tex_BS_35

**TRACTOR - - MODEL NO. M13597 (96041009102), PRODUCT NO. 960 41 00-91
ENGINE 24**

KEY NO.	PART NO.	DESCRIPTION
1	-----	Engine B & S, Model No. 21B807-1393-B1
2	532 17 97-58	Muffler
9	532 19 43-19	Keeper Belt Engine
12	532 40 19-85	Pulley Engine
15	532 40 75-45	Tank Fuel 1.5
18	532 43 02-20	Cap Asm
20	532 41 17-24	Control Throttle
21	532 41 63-58	Screw #10 x .750 BOS Thread
22	532 41 17-25	Control Choke
28	532 13 70-40	Fuel Line
29	532 13 71-80	Spark Arrester Kit
37	532 12 34-87	Clamp Hose
42	810 04 07-00	Washer
45	873 51 04-00	Nut Keps Hex 1/4-20 unc
69	532 16 52-91	Gasket
79	532 19 23-34	Screw Socket 5/16-18 x .75
84	817 06 06-20	Screw 3/8-16 x 1-1/4
85	532 17 39-37	Bolt Hex 7/16-20 x 4 Gr. 5
90	817 00 06-16	Screw 3/8-16 x 1
96	819 09 14-16	Washer 9/32 x 7/8 x 16 Ga.
97	817 67 04-12	Screw Hexwsh Thdrol 1/4-20 x 3/4
105	532 44 06-81	Shield, Side LH
106	532 44 06-80	Shield, Side RH
108	532 42 17-94	Asm. Cover
122	532 42 19-22	Extension Drain Oil

NOTE: All component dimensions given in U.S. inches
1 inch = 25.4 mm

Engine Power Rating Information

The gross power rating for individual gas engine models is labeled in accordance with SAE (Society of Automotive Engineers) code J1940 (Small Engine Power & Torque Rating Procedure), and rating performance has been obtained and corrected in accordance with SAE J1995 (Revision 2002-05). Torque values are derived at 3060 RPM; horsepower values are derived at 3600 RPM. Actual gross engine power will be lower and is affected by, among other things, ambient operating conditions and engine-to-engine variability. Given both the wide array of products on which engines are placed and the variety of environmental issues applicable to operating the equipment, the gas engine will not develop the rated gross power when used in a given piece of power equipment (actual "on-site" or net power). This difference is due to a variety of factors including, but not limited to, accessories (air cleaner, exhaust, charging, cooling, carburetor, fuel pump, etc.), application limitations, ambient operating conditions (temperature, humidity, altitude), and engine-to-engine variability. Due to manufacturing and capacity limitations, Briggs & Stratton may substitute an engine of higher rated power for this Series engine.

TRACTOR - - MODEL NO. M13597 (96041009102), PRODUCT NO. 960 41 00-91
STEERING ASSEMBLY **41**

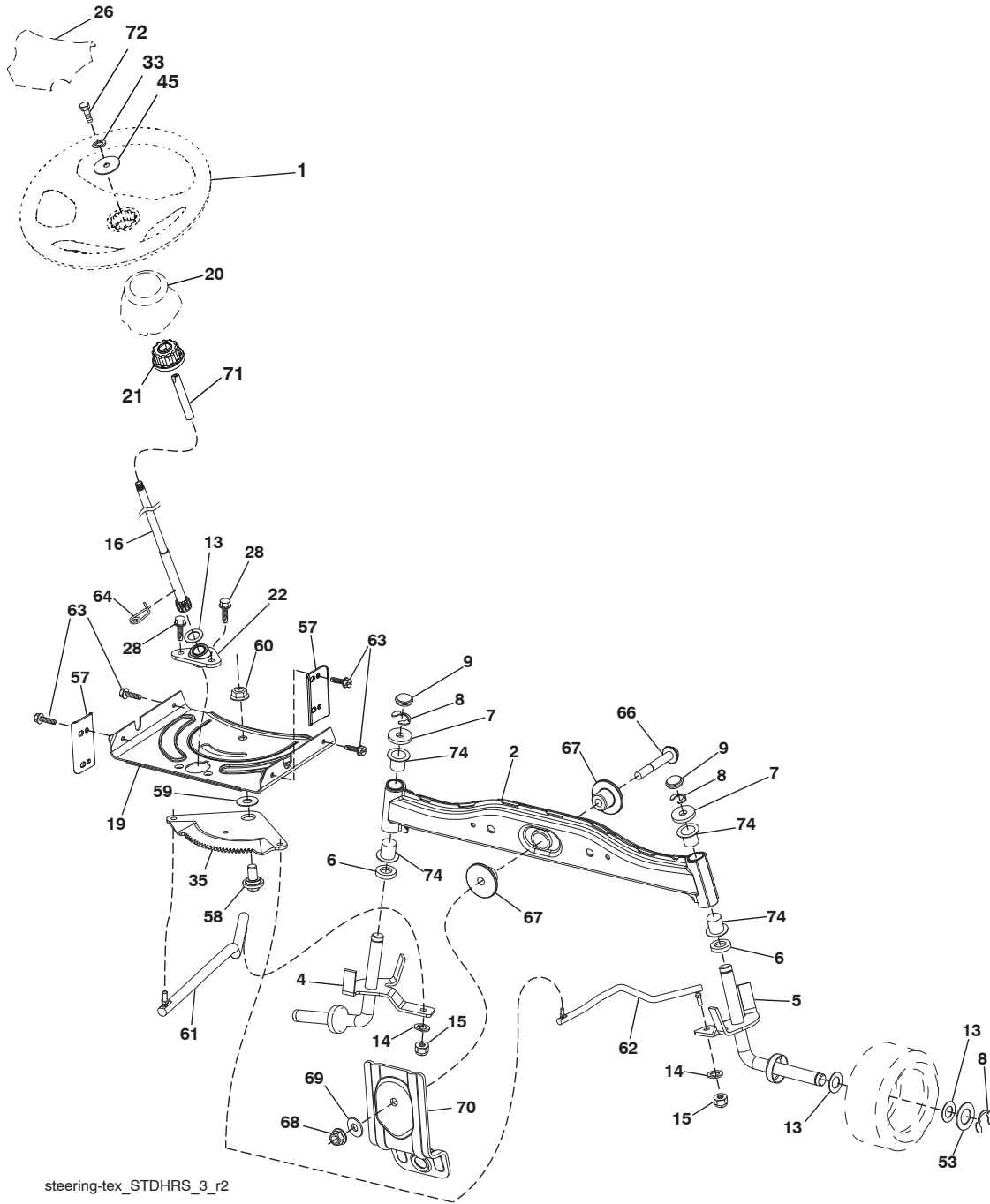

steering-tex_STDHRS_3_r2

**TRACTOR - - MODEL NO. M13597 (96041009102), PRODUCT NO. 960 41 00-91
STEERING ASSEMBLY 41**

KEY NO.	PART NO.	DESCRIPTION
1	532 42 41-46	Wheel, Steering
2	532 41 81-68	Axle Asm., Front
4	532 40 30-87	Spindle Asm., LH
5	532 40 30-88	Spindle Asm., RH
6	532 12 49-31	Bearing, Race Thrust Harden
7	532 12 17-48	Washer 25/32 x 1-5/8 x 16 Ga.
8	812 00 00-29	Ring, Clip #T5304-75
9	532 12 12-32	Cap, Spindle
13	532 12 17-49	Washer 25/32 x 1-1/4 x 16 Ga.
14	810 04 06-00	Washer, Lock Hvy. Hlcl. Spr. 3/8
15	873 54 06-00	Nut, Crown Lock 3/8-24 unf
16	532 42 93-73	Shaft Steering
19	532 19 47-29	Plate Steering
20	532 41 12-91	Boot, Steering
21	532 18 67-37	Adapter, Wheel Steering
22	532 42 05-37	Steering Support Lower
26	532 42 46-91	Insert, Wheel Steering
28	817 00 06-12	Screw 3/8-16 x 3/4
33	810 04 05-00	Washer Lock 5/16
35	532 19 47-32	Gear, Sector Plate
45	819 11 38-12	Washer 11/32 x 2-3/8 x 12 Ga.
53	532 18 89-67	Washer Hardened .793 x 1.637 x .060
57	532 40 74-65	Bracket Upstop
58	532 19 47-47	Bolt Shoulder Sector Pivot CFM
59	532 19 47-48	Washer Thrust Sector Steering
60	873 97 10-00	Nut Flange Lock 5/8-11
61	532 19 47-40	Draglink LH
62	532 19 47-41	Draglink, RH
63	817 00 05-12	Screw 5/16-18 x 3/4
64	532 19 98-49	Retainer Clip Spring Steering
66	871 02 07-48	Bolt Hex Fghd. 7/16-14 x 3 Serr.
67	532 19 47-37	Bushing PM Front Axle
68	873 90 07-00	Nut Lock Flange 7/16-14 Gr. 5
69	532 19 91-62	Washer 1.5 x .505 x .118
70	532 19 61-97	Bracket Deck Susp. Front
71	532 19 07-52	Shaft Ext. Steering
72	532 42 89-82	Bolt Fin Hex 5/16-18 x 4 w/Patch
74	532 12 49-37	Bearing

NOTE: All component dimensions given in U.S. inches
1 inch = 25.4 mm

TRACTOR - - MODEL NO. M13597 (96041009102), PRODUCT NO. 960 41 00-91
MOWER DECK **44**

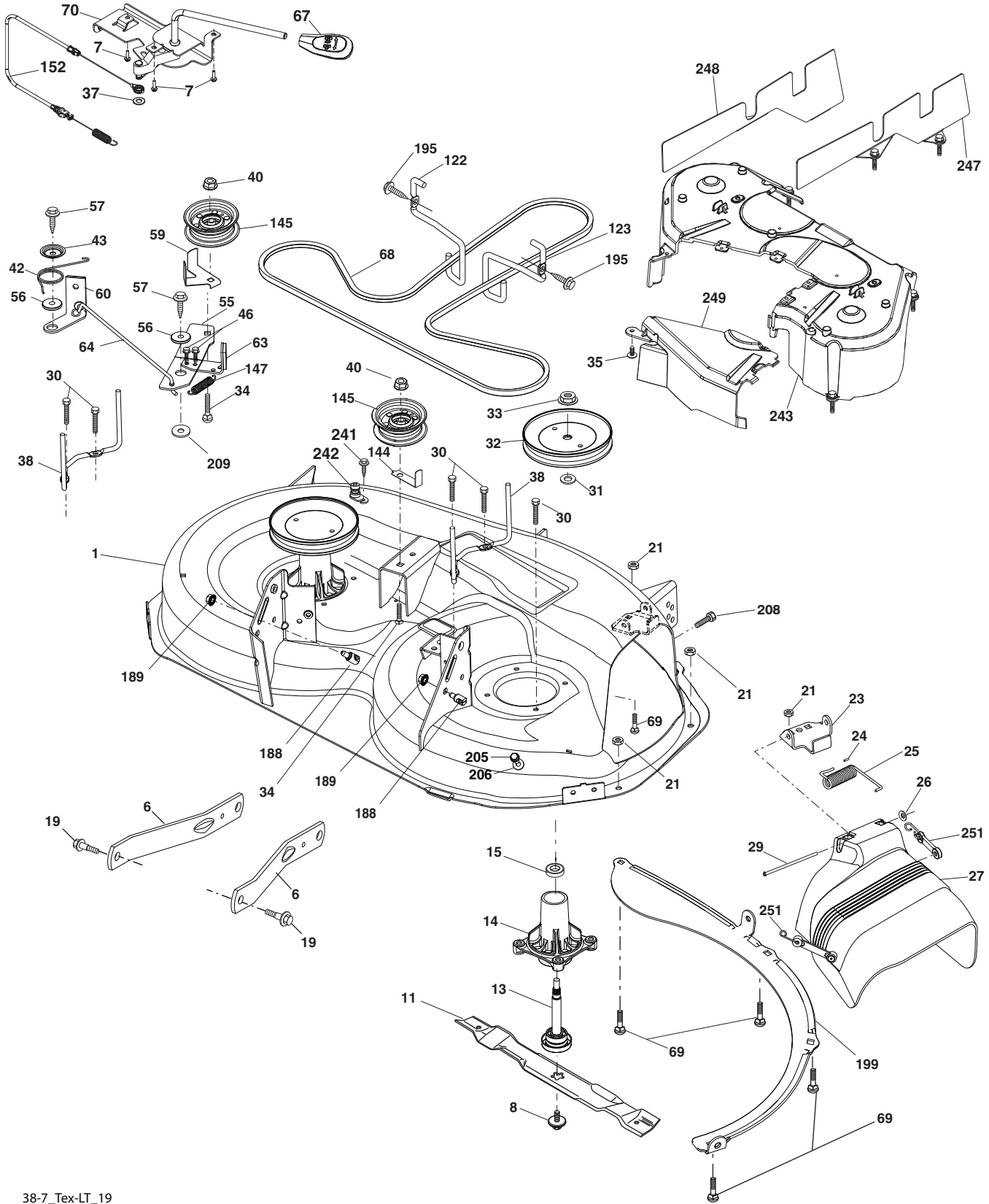

38-7_Tex-LT_19

**TRACTOR - - MODEL NO. M13597 (96041009102), PRODUCT NO. 960 41 00-91
MOWER DECK 44**

KEY NO.	PART NO.	DESCRIPTION	KEY NO.	PART NO.	DESCRIPTION
1	532 19 42-51	Mower Housing	67	532 40 97-92	Handle Clutch Cable
6	532 19 51-86	Arm Suspension	68	532 40 83-81	V-Belt
7	532 41 63-58	Screw #10 x 0.750 BOS Thread	69	872 14 05-05	Bolt
8	532 19 30-03	Bolt/Washer Asm. 7/16-20 unf	70	532 19 83-32	Clutch Asm. Manual
11	532 19 39-57	Blade 38" 3NI Premium	122	532 19 72-58	Keeper Belt Engine LH
13	532 19 28-72	Shaft Assembly, Mandrel	123	532 19 72-59	Keeper Belt Engine RH
14	532 18 72-81	Housing, Mandrel	144	532 19 34-14	Keeper Belt
15	532 11 04-85	Bearing, Ball, Mandrel	145	532 19 31-97	Pulley Idler
19	532 19 65-39	Bolt, Shoulder	147	532 40 18-72	Spring Return
21	873 68 05-00	Nut, Crownlock 5/16-18 unc	152	532 40 87-14	Manual Clutch Cable
23	532 19 25-57	Bracket, Deflector	188	532 19 51-61	Stud Fastener
24	532 10 53-04	Cap, Sleeve	189	873 90 05-00	Nut Lock Hex Flange
25	532 19 70-26	Spring, Torsion, Deflector	195	817 00 06-12	Screw 3/8-16 x 3/4
26	532 11 04-52	Nut, Push	199	532 40 00-95	Baffle Vortex
27	532 40 16-18	Shield, Deflector	205	817 49 04-16	Screw 1/4 - 20 x 1.00 77
29	532 13 14-91	Rod, Hinge	206	819 09 14-16	Washer 9/32 x 7/8 x 16 Ga.
30	532 17 39-84	Screw Thdrol. Rolling Wsh. Hd.	208	817 67 06-08	Screw 3/8 - 16 x 1/2
31	532 18 76-90	Washer, Spacer	209	819 13 32-10	Washer 13/32 x 2 x 10
32	532 19 97-89	Pulley, Mandrel	241	532 15 29-27	Screw TT #10-32.5 3/8 Flng
33	532 40 02-34	Nut, Toplock, Flanged	242	532 41 55-98	Port Washout
34	872 11 06-12	Bolt Carr. Sh. 3/8-16 x 1-1/2 Gr. 5	243	532 43 23-63	Cover Assy
35	532 13 38-35	Fastener, Christmas Tree	247	532 43 23-60	Shield Deck RH Assy
37	819 13 13-16	Washer	248	532 43 23-61	Shield Deck LH Assy
38	532 19 95-41	Keeper Belt LH Mandrel	249	532 40 65-14	Cover Cable Clutch
40	873 90 06-00	Nut, Lock Flg. 3/8-16 unc	251	532 43 60-87	Kit Bungee (Includes Phillips head screw, weld nut, screw, bungee latch, and bungee strap)
42	532 19 84-10	Spring Torsion Brake	--	532 19 28-70	Mandrel Assembly (Includes housing, shaft assembly, and bearing only - pulley/nut/washer and blade bolt/washers not included)
43	532 19 72-56	Spring Torsion Retainer	--	532 43 16-91	Replacement Mower, Complete
46	532 13 77-29	Screw 1/4 - 20 x 5/8			
55	532 19 72-49	Arm, Idler			
56	532 19 90-92	Spacer, Retainer			
57	817 00 06-16	Screw 3/8-16 x 1			
59	532 14 10-43	Guard, Tuv. Idler			
60	532 19 94-71	Arm Brake Mower			
63	532 19 94-70	Arm Brake Mower			
64	532 19 97-90	Link Brake			

NOTE: All component dimensions given in U.S. inches
1 inch = 25.4 mm

**TRACTOR - - MODEL NO. M13597 (96041009102), PRODUCT NO. 960 41 00-91
MOWER LIFT 45**

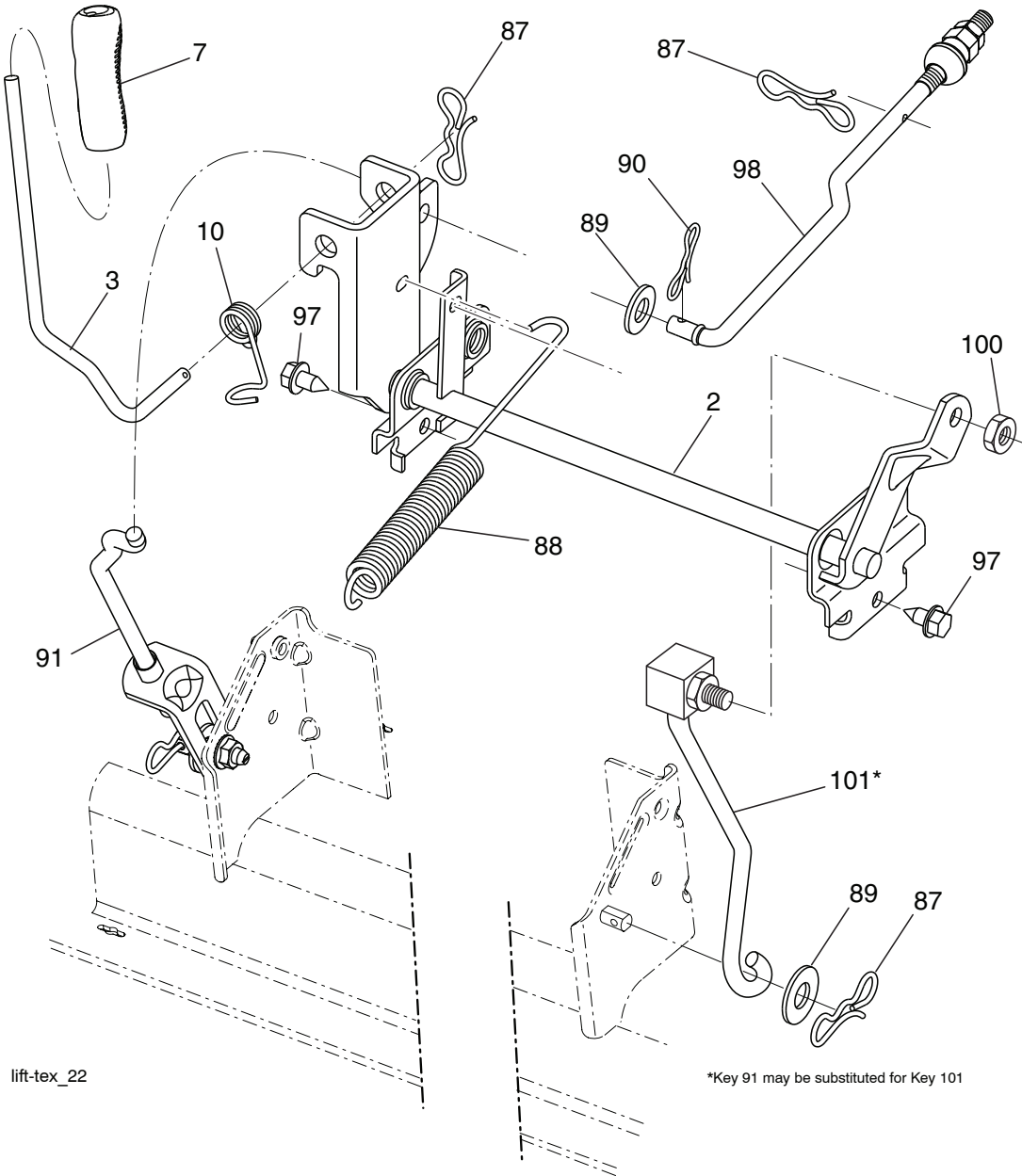

KEY NO.	PART NO.	DESCRIPTION
2	532 42 20-27	Shaft Asm., Lift
3	532 19 52-31	Lever Asm., Lift RH
7	532 41 17-42	Grip, Lever
10	532 19 63-14	Spring Torsion
87	532 19 42-09	Pin Cotter 7/16 Bow Tie Lock
88	532 41 07-10	Spring Lift Assist
89	819 19 19-12	Washer Clear Zinc
90	532 19 42-08	Pin Cotter 5/16 Bow Tie Lock

KEY NO.	PART NO.	DESCRIPTION
91	532 19 51-81	Link Lift Susp Mower Rear
97	817 00 06-12	Screw 3/8-16 x .75
98	532 19 52-70	Link Lift Susp. Front Mower
100	873 93 06-00	Nut Centerlock 3/8-16
101	532 40 70-03	Link Asm Lift FXD

NOTE: All component dimensions given in U.S. inches
1 inch = 25.4 mm

**TRACTOR - - MODEL NO. M13597 (96041009102), PRODUCT NO. 960 41 00-91
SEAT ASSEMBLY 42**

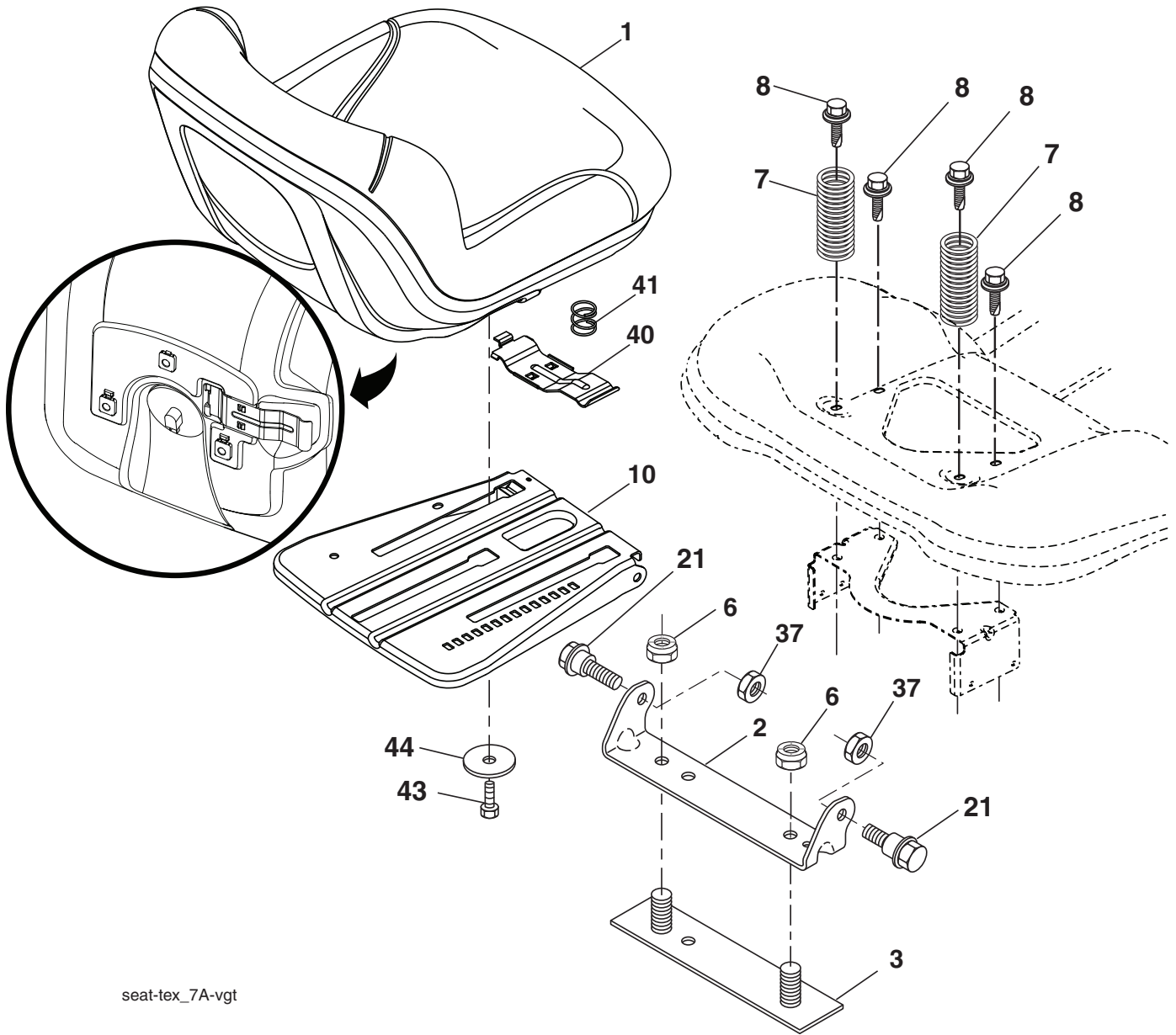

KEY NO.	PART NO.	DESCRIPTION
1	532 19 75-11	Seat
2	532 18 01-66	Bracket Pivot Fender
3	532 14 06-75	Strap, Asm Fender
6	873 80 06-00	Nut, Lock w/Ins. 3/8-16 unc
7	532 12 41-81	Spring, Seat Cprsn
8	532 17 18-77	Bolt 5/16-18 unc x 3/4 w/Sems
10	532 19 69-77	Pan, Seat
21	532 17 18-52	Bolt, Shoulder 5/16-18

KEY NO.	PART NO.	DESCRIPTION
37	873 80 05-00	Nut, Lock 5/16-18 unc
40	532 19 76-61	Handle Slide
41	532 19 82-00	Spring Latch
43	874 76 06-12	Bolt Fin Hex 3/8-16 unc x 3/4
44	819 13 38-12	Washer 13/32 x 2-3/8 x 12 Ga.

NOTE: All component dimensions given in U.S. inches
1 inch = 25.4 mm

