

REPAIR PARTS MANUAL
MODEL NO. M155107H (96041001004)
Lawn Tractor



McCULLOCH

www.mcculloch.biz

HOW TO USE THIS MANUAL

This manual is designed to provide the customer with a means to identify the parts on his/her tractor when ordering repair parts. The illustrations may or may not represent the actual assemblies; therefore, it is not recommended to use this manual as a guide to assemble or disassemble the tractor. Some hardware and parts are drawn larger in order to more readily identify them.

Each tractor has its own model number.

The model number for your tractor can be found on the fender under the seat.

When ordering parts, always give the following information:

- Product - "Tractor"
- Model Number - "M155107H (96041001004)"
- Part Number
- Part Description

TABLE OF CONTENTS

SCHEMATIC	3
ELECTRICAL.....	4-5
CHASSIS	6-7
DRIVE.....	8-9
STEERING	10-11
ENGINE.....	12-13
SEAT	14
DECALS.....	15
MOWER DECK	16-17
MOWER LIFT.....	18

TRACTOR - MODEL NO. M155107H (96041001004), PRODUCT NO. 960 41 00-10 SCHEMATIC

SCH12

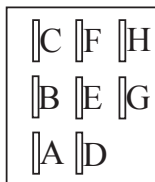
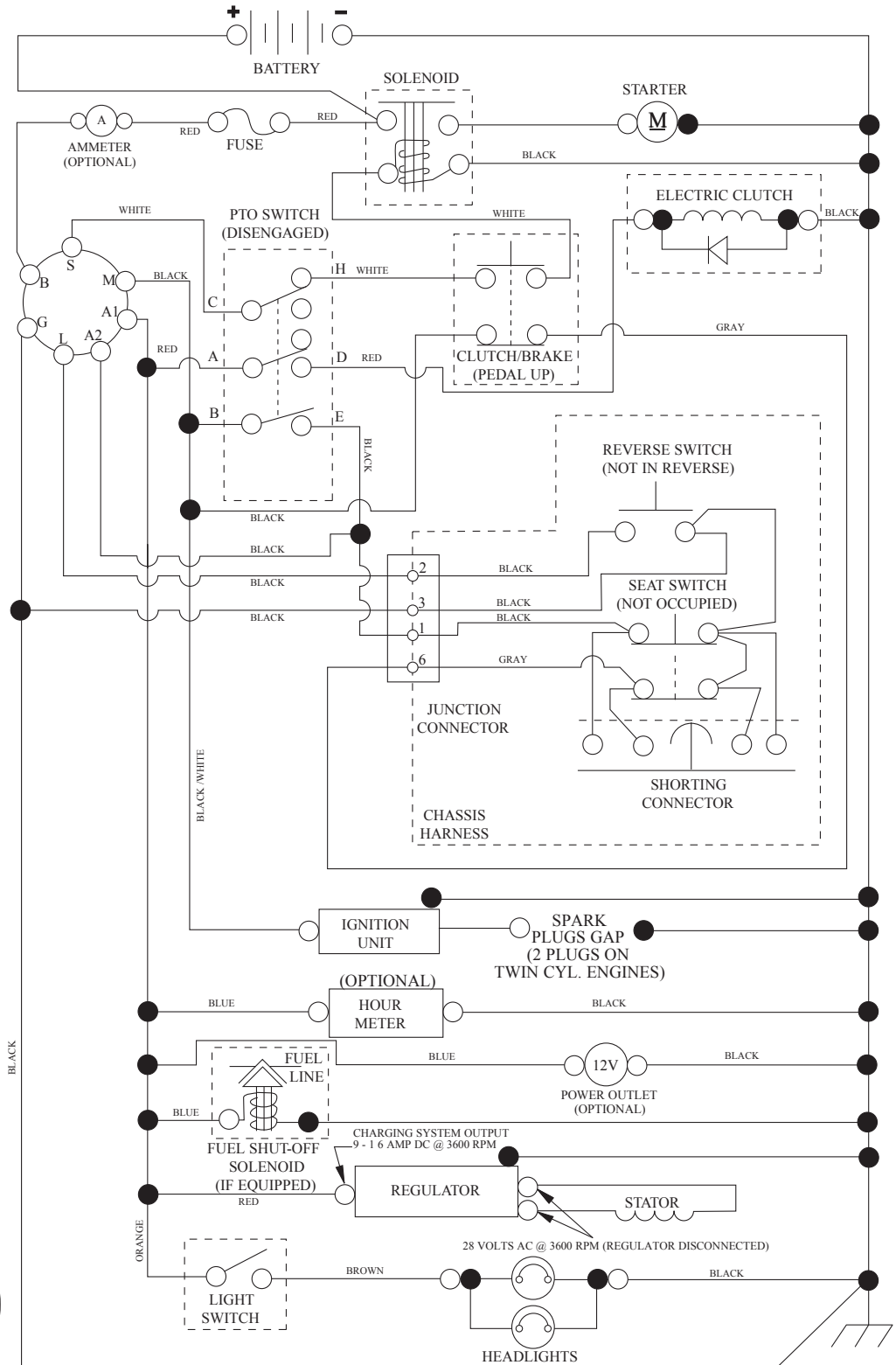

PTO SWITCH (MATING SIDE)

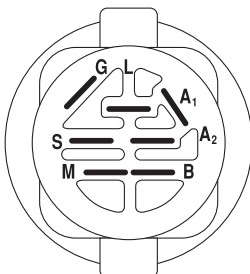

POSITION	CIRCUIT	"MAKE"
OFF	M+G+A1	
RUN/OVERRIDE	B+A1	
RUN	B+A1	L+A2
START	B+S+A1	

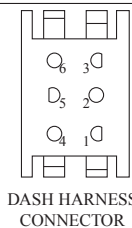

WIRING INSULATED CLIPS
NOTE: IF WIRING INSULATED CLIPS WERE REMOVED FOR SERVICING OF UNIT, THEY SHOULD BE RE-INSTALLED TO PROPERLY SECURE YOUR WIRING.

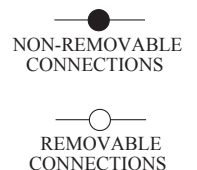

TRACTOR - MODEL NO. M155107H (96041001004), PRODUCT NO. 960 41 00-10 ELECTRICAL

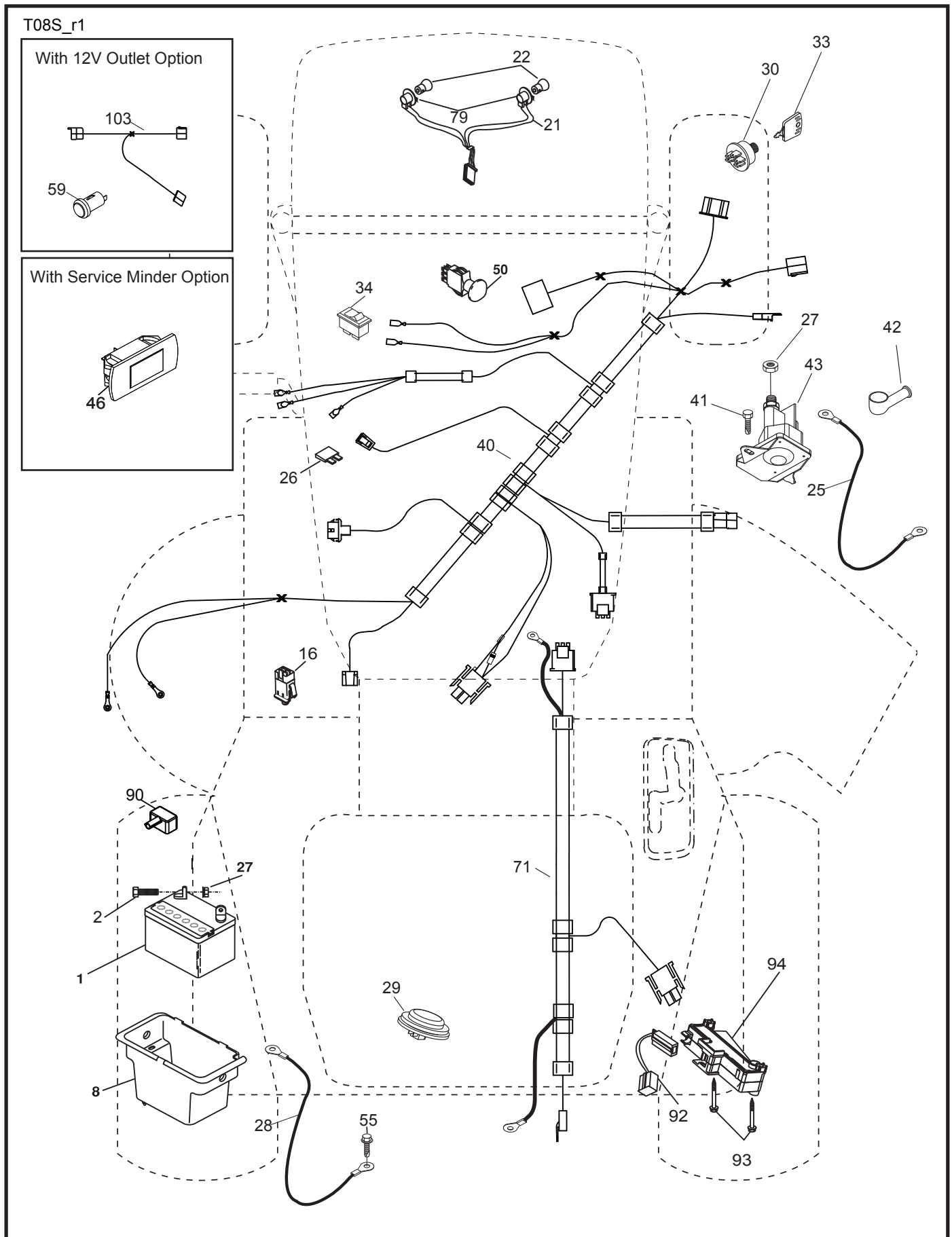

**TRACTOR - MODEL NO. M155107H (96041001004), PRODUCT NO. 960 41 00-10
ELECTRICAL**

KEY NO.	PART NO.	DESCRIPTION
1	532 16 34-65	Battery
2	874 76 04-12	Bolt Hex Hd 1/4-20 unc x 3/4
8	532 19 32-28	Battery Box
16	532 17 61-38	Switch Interlock
21	532 17 56-88	Harness Socket Light
22	532 00 41-52	Bulb, Light #1156
25	532 41 28-95	Cable Starter
26	532 17 51-58	Fuse
27	873 51 04-00	Nut Keps Hex 1/4-20 unc
28	532 19 88-85	Cable Ground
29	532 40 15-45	Switch Seat
30	532 19 33-50	Switch Ign
33	532 41 19-35	Key/Chain
34	532 11 07-12	Switch Light/Reset
40	532 40 11-04	Harness Ign. Dash
41	817 72 04-08	Screw Thd Cut 1/4-20 x 1/2
42	532 13 15-63	Cover Terminal Red
43	532 19 25-07	Solenoid
50	532 17 46-53	Switch PTO
55	817 06 05-12	Screw Thdrol 5/16-18 x 3/4
71	532 40 04-49	Harness Chassis
79	532 17 52-42	Socket Asm. Bulb
90	532 40 07-25	Cover Terminal Battery
92	532 19 66-15	Harness Pigtail Console ROS
93	532 19 25-40	Screw Plastite 10-14 x 2.0
94	532 19 18-34	Module Reverse ROS

NOTE: All component dimensions given in U.S. inches
1 inch = 25.4 mm

TRACTOR - MODEL NO. M155107H (96041001004), PRODUCT NO. 960 41 00-10 CHASSIS

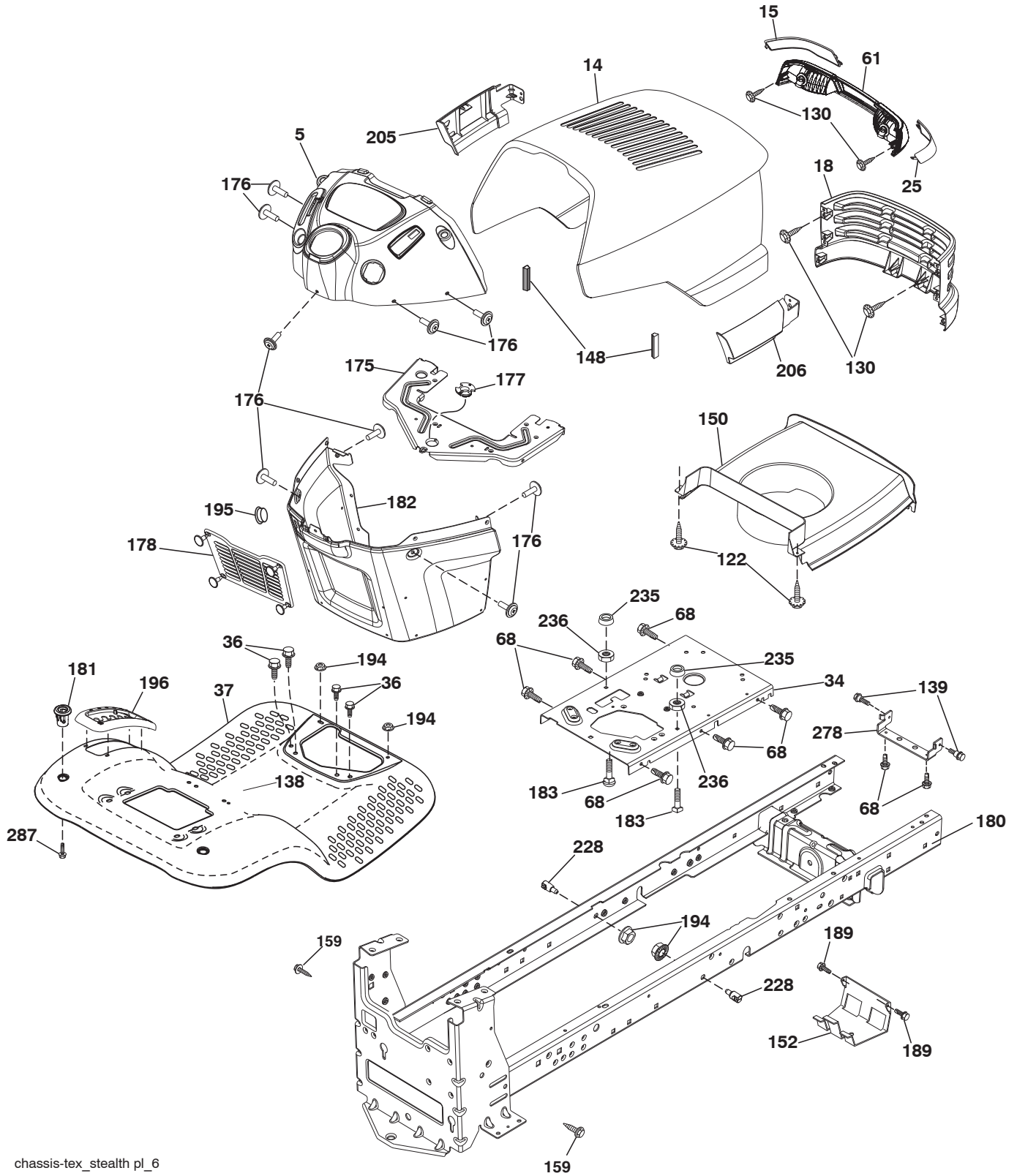

chassis-tex_stealth pl_6

**TRACTOR - MODEL NO. M155107H (96041001004), PRODUCT NO. 960 41 00-10
CHASSIS**

KEY NO.	PART NO.	DESCRIPTION
5	532 41 14-10	Dash
14	532 19 49-77	Hood
15	532 16 18-41	Lens LH
18	532 18 71-14	Grille
25	532 16 18-42	Lens RH
34	532 19 61-25	Plate Engine
36	817 06 05-12	Screw 5/16-18 x 3/4
37	532 42 41-80	Fender
61	532 17 97-63	Light Asm Dual
68	817 49 05-08	Screw THDROL 5/16-18 x 1/2 TYTT
122	532 19 25-12	Screw 10-32 x 5/8
130	532 41 63-58	Screw #10 x .750 BOS Thread
139	532 17 18-73	Bolt Shoulder 5/16-18
148	532 16 46-55	Bumper Extrusion
150	532 19 03-08	Air Duct
152	532 19 95-35	Shield Browning
159	817 00 06-12	Screw 3/8-16 x 3/4
175	532 19 32-36	Crossmember
176	532 40 07-76	Screw 10-24 x 5/8
177	532 19 52-27	Bushing Steering
178	532 19 56-51	Cargo Net Asm.
180	532 19 54-57	Chassis
181	532 40 47-96	Bushing Mtg. Fender Crgo
182	532 19 25-51	Dash Lower
183	874 52 05-20	Bolt Fin Hex 5/16-18 unc x 1-1/4
189	817 00 05-12	Screw 5/16-18 x 3/4
194	873 90 05-00	Nut Lock Hex Flange 5/16-18
195	532 40 41-37	Plug Hole Dash Lower
196	532 41 45-81	Console Asm. Deck Lift
205	532 18 71-12	Skirt Hood Side LH
206	532 18 71-11	Skirt Hood Side RH
228	532 19 51-61	Stud Fastner
235	532 40 61-29	Spacer Fender
236	873 93 05-00	Nut Lock 5/16-18 unc
278	532 19 63-94	Bracket Hood/Muff
287	817 60 04-06	Screw Hex 1/4-20 x 3/8
--	532 41 17-08	Plug Dash
--	532 41 14-11	Plug Cruise Control

NOTE: All component dimensions given in U.S. inches
1 inch = 25.4 mm

TRACTOR - MODEL NO. M155107H (96041001004), PRODUCT NO. 960 41 00-10 DRIVE

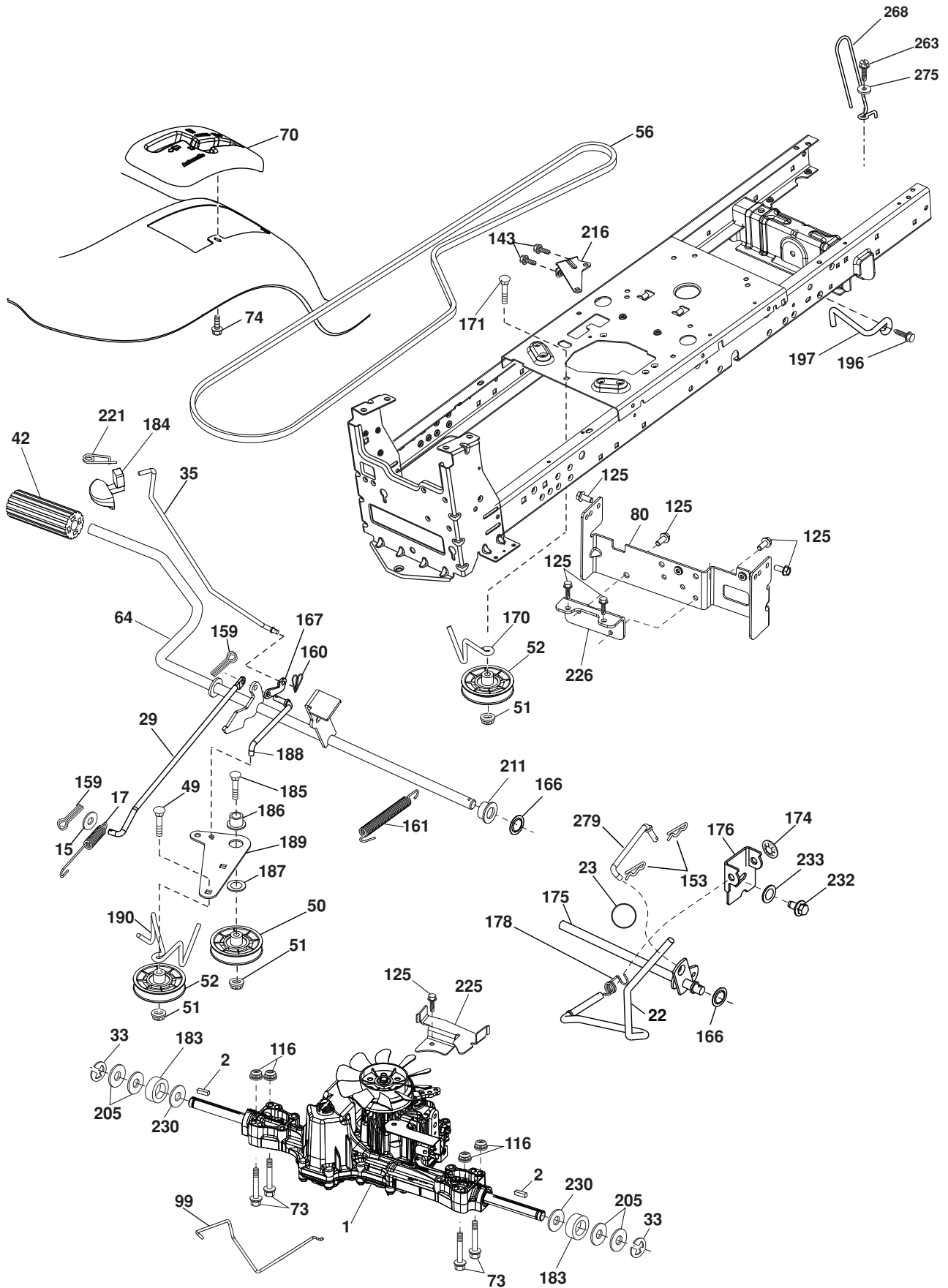

drive-tex_K46_fender_21

**TRACTOR - MODEL NO. M155107H (96041001004), PRODUCT NO. 960 41 00-10
DRIVE**

KEY NO.	PART NO.	DESCRIPTION	KEY NO.	PART NO.	DESCRIPTION
1	---	Transaxle, TUFFTORQ K46 (Order parts from transaxle manufacturer)	167	532 40 52-57	Latch Brake Parking
2	532 12 35-83	Key	170	532 19 43-22	Keeper Belt Centerspan
15	819 13 13-16	Washer 13/32 x 13/16 x 16 Ga.	171	872 11 06-16	Bolt RDHD SQNK 3/8-16 unc x 2
17	532 41 31-78	Spring, Brake	174	532 19 72-89	Nut Push
22	532 19 76-60	Rod Shift	175	532 40 62-08	Shaft Asm Shift
23	532 41 14-00	Knob	176	532 19 62-14	Arm Clevis Rod Shift
29	532 40 38-06	Rod, Brake	178	532 19 74-56	Spring Shift
33	812 00 00-01	Ring E	183	532 13 70-57	Spacer Split
35	532 19 72-75	Rod, Brake, Park	184	532 41 17-16	Handle Parking Brake
42	532 12 48-72	Cover, Foot Pedal	185	872 11 06-22	Bolt Rdhd Sqnk 3/8-16 x 2-3/4
49	872 11 06-14	Bolt	186	532 19 43-21	Spacer Retainer
50	532 19 43-27	Pulley Idler Flat	187	819 13 32-10	Washer
51	873 90 06-00	Lock Nut 3/8-16	188	532 19 43-23	Link Clutch Ground Drive
52	532 19 43-26	Idler V-Groove 910" Offset	189	532 19 43-17	Bellcrank Ground Drive
56	532 13 09-69	V-Belt, Drive	190	532 19 43-18	Keeper Bellcrank Ground Drive
64	532 19 62-00	Shaft Asm. Pedal Brake Control	196	817 00 06-16	Screw 3/8-16 x 1
70	532 41 13-29	Console	197	532 19 58-04	Bracket Clutch Anti-Rotation
73	874 49 05-44	Bolt Hex Flgnd 5/16-18 Gr. 5	205	532 12 17-48	Washer
74	532 14 24-32	Screw 1/4 x 1/2	211	532 19 62-12	Bushing Brake Shaft
80	532 41 00-24	Strap Torque	216	532 19 61-31	Bracket Pulley Idler
99	532 41 57-42	Rod Bypass	221	532 40 31-87	Retainer Spring Clip Handle
116	873 90 05-00	Nut Lock Hex Flange 5/16-18	225	532 40 33-19	Keeper Belt Trans.
125	817 00 05-12	Screw 5/16-18 x 3/4	226	532 40 15-64	Bracket Mount Touque
143	817 49 05-08	Screw Thdrol 5/16-18 x 1/2	230	532 18 89-67	Washer Hardened
153	532 12 47-88	Retainer Spring	233	532 40 52-96	Washer Serrated
159	876 02 04-12	Pin Cotter 1/8 x 3/4	263	817 00 06-12	Screw 3/8-16 x 3/4
160	532 16 94-84	Retainer Clip	268	532 18 24-02	Guard Muffler
161	532 10 57-09	Spring, Return, Clutch	275	819 13 16-14	Washer 13/32 x 1 x 14 Ga.
166	532 42 91-64	Nut Push	276	874 78 07-16	Bolt 7/16-14 x 1 Gr. 5

NOTE: All component dimensions given in U.S. inches
1 inch = 25.4 mm

TRACTOR - MODEL NO. M155107H (96041001004), PRODUCT NO. 960 41 00-10
STEERING ASSEMBLY

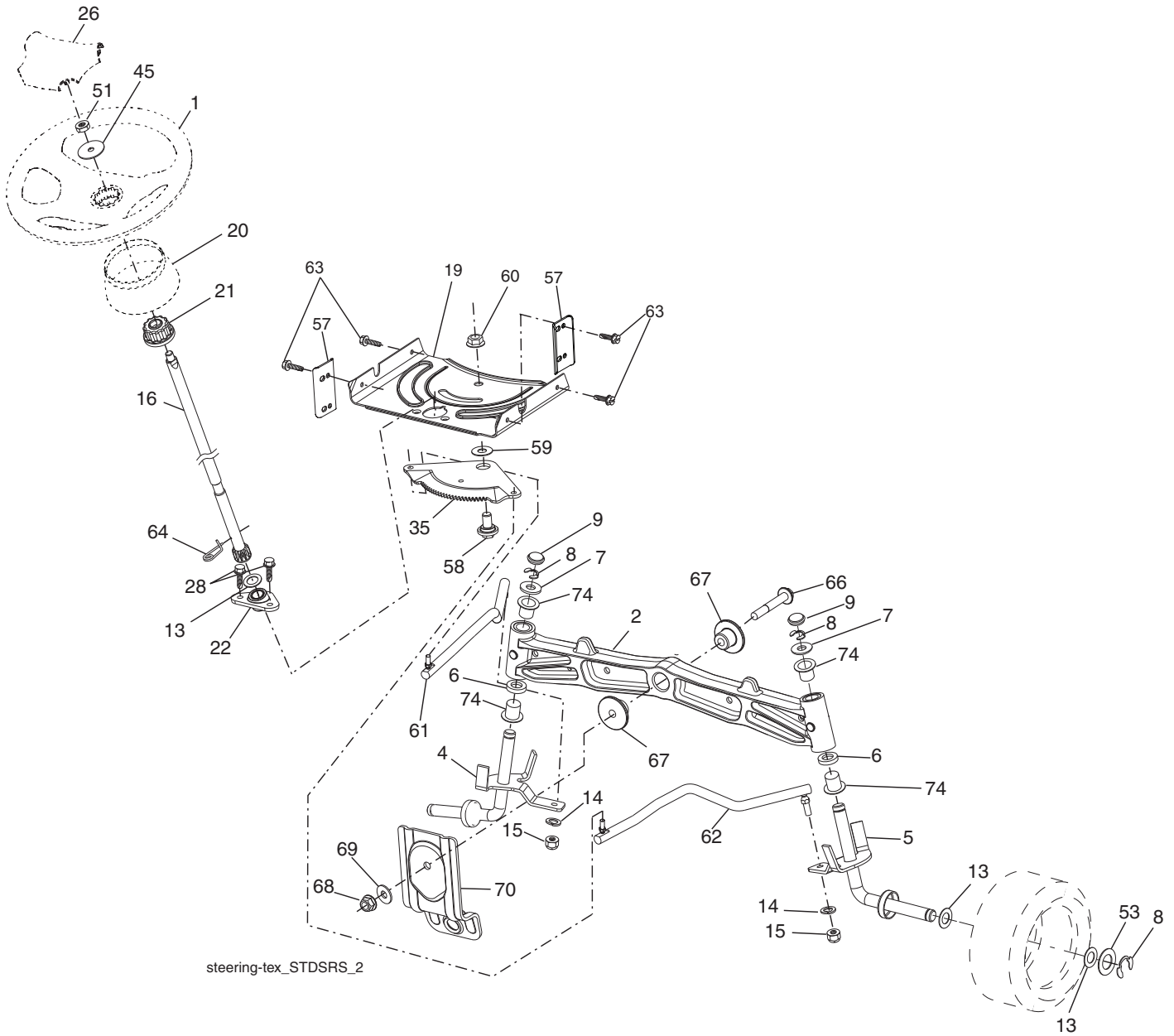

**TRACTOR - MODEL NO. M155107H (96041001004), PRODUCT NO. 960 41 00-10
STEERING ASSEMBLY**

KEY NO.	PART NO.	DESCRIPTION
1	532 42 41-46	Wheel, Steering
2	532 41 81-68	Axle Asm., Front
4	532 40 30-87	Spindle Asm., LH
5	532 40 30-88	Spindle Asm., RH
6	532 12 49-31	Washer .75 x 1.230 Thrust
7	532 12 17-48	Washer 25/32 x 1-5/8 x 16 Ga.
8	812 00 00-29	Ring, Clip #T5304-75
9	532 12 12-32	Cap, Spindle
13	532 12 17-49	Washer 25/32 x 1-1/4 x 16 Ga.
14	810 04 06-00	Washer, Lock Hvy Hlcl Spr 3/8
15	873 54 06-00	Nut, Crown Lock 3/8-24 unf
16	532 19 47-46	Shaft Steering
19	532 19 47-29	Plate Steering
20	532 41 14-25	Boot Steering
21	532 18 67-37	Adapter, Wheel Steering
22	532 42 05-37	Steering Supt. Lower
26	532 42 46-91	Insert, Wheel Steering
28	817 00 06-12	Screw 3/8-16 x 3/4
35	532 19 47-32	Gear, Sector Plate
45	819 11 38-12	Washer 11/32 x 2-3/8 x 12 Ga.
51	873 94 08-00	Nut Hex Jam Toplock 1/2-20 unf
53	532 18 89-67	Washer Hardened .793 x 1.637 x .060
57	532 40 74-65	Bracket Upstop
58	532 19 47-47	Bolt Shoulder Sector Pivot CFM
59	532 19 47-48	Washer Thrust Sector Steering
60	873 97 10-00	Nut Flange Lock 5/8-11
61	532 19 47-40	Draglink, LH
62	532 19 47-41	Draglink, RH
63	817 00 05-12	Screw 5/16-18 x 3/4
64	532 19 98-49	Retainer Clip Spring Steering
66	871 02 07-48	Bolt Hex Fghd 7/16-14 x 3 Serr
67	532 19 47-37	Bushing PM Front Axle
68	873 90 07-00	Nut Lock Flange 7/16-14 Gr. 5
69	532 19 91-62	Washer 1.5 x .505 x .118
70	532 19 61-97	Bracket Deck Susp. Front
74	532 12 49-37	Bearing
78	532 05 70-79	Washer Thrust .515 x .750 x .033

NOTE: All component dimensions given in U.S. inches
1 inch = 25.4 mm

**TRACTOR - MODEL NO. M155107H (96041001004), PRODUCT NO. 960 41 00-10
ENGINE**

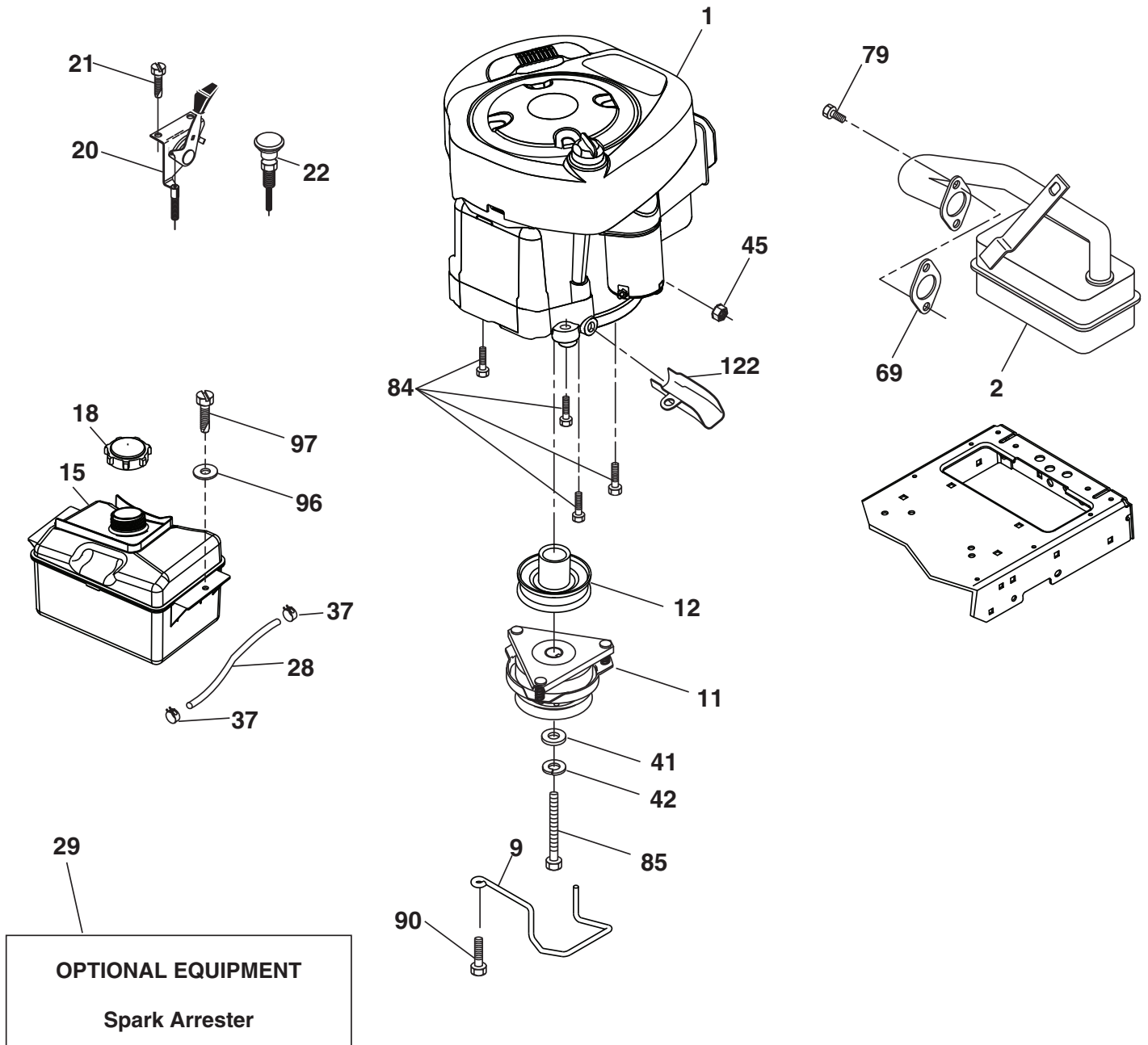

engine-tex_BS_43

**TRACTOR - MODEL NO. M155107H (96041001004), PRODUCT NO. 960 41 00-10
ENGINE**

KEY NO.	PART NO.	DESCRIPTION
1	---	Engine Briggs Model No. 31A607-1432-B1 (Order parts from engine manufacturer)
2	532 13 73-52	Muffler
9	532 19 43-20	Keeper Belt Engine
11	532 18 05-05	Clutch Electric
12	532 40 50-97	Pulley Engine
15	532 40 75-16	Tank Fuel
18	532 43 02-20	Cap Asm
20	532 41 17-24	Control Throttle
21	532 41 63-58	Screw #10 x .750 BOS Thread
22	53241 17-25	Control Choke
28	532 13 70-40	Fuel Line
29	532 13 71-80	Spark Arrester Kit
37	532 12 34-87	Clamp Hose
41	532 12 61-97	Washer 1-1/2 OD x 15/32 ID x .250
42	810 04 07-00	Washer Lock 7/16
45	873 51 04-00	Nut Keps Hex 1/4-20 unc
69	532 16 52-91	Gasket
79	532 19 23-34	Screw 5/16-18 x .75
84	817 06 06-20	Screw 3/8-16 x 1-1/4
85	532 17 39-37	Bolt 7/16-20 x 4
90	817 00 06-16	Screw 3/8-16 x 1
96	819 09 14-16	Washer 9/32 x 7/8 x 16 Ga.
97	817 67 04-12	Screw 1/4 - 20 x 3/4
122	532 42 19-22	Extension Drain Oil

NOTE: All component dimensions given in U.S. inches
1 inch = 25.4 mm

Engine Power Rating Information

The gross power rating for individual gas engine models is labeled in accordance with SAE (Society of Automotive Engineers) code J1940 (Small Engine Power & Torque Rating Procedure), and rating performance has been obtained and corrected in accordance with SAE J1995 (Revision 2002-05). Torque values are derived at 3060 RPM; horsepower values are derived at 3600 RPM. Actual gross engine power will be lower and is affected by, among other things, ambient operating conditions and engine-to-engine variability. Given both the wide array of products on which engines are placed and the variety of environmental issues applicable to operating the equipment, the gas engine will not develop the rated gross power when used in a given piece of power equipment (actual "on-site" or net power). This difference is due to a variety of factors including, but not limited to, accessories (air cleaner, exhaust, charging, cooling, carburetor, fuel pump, etc.), application limitations, ambient operating conditions (temperature, humidity, altitude), and engine-to-engine variability. Due to manufacturing and capacity limitations, Briggs & Stratton may substitute an engine of higher rated power for this Series engine.

**TRACTOR - MODEL NO. M155107H (96041001004), PRODUCT NO. 960 41 00-10
SEAT ASSEMBLY**

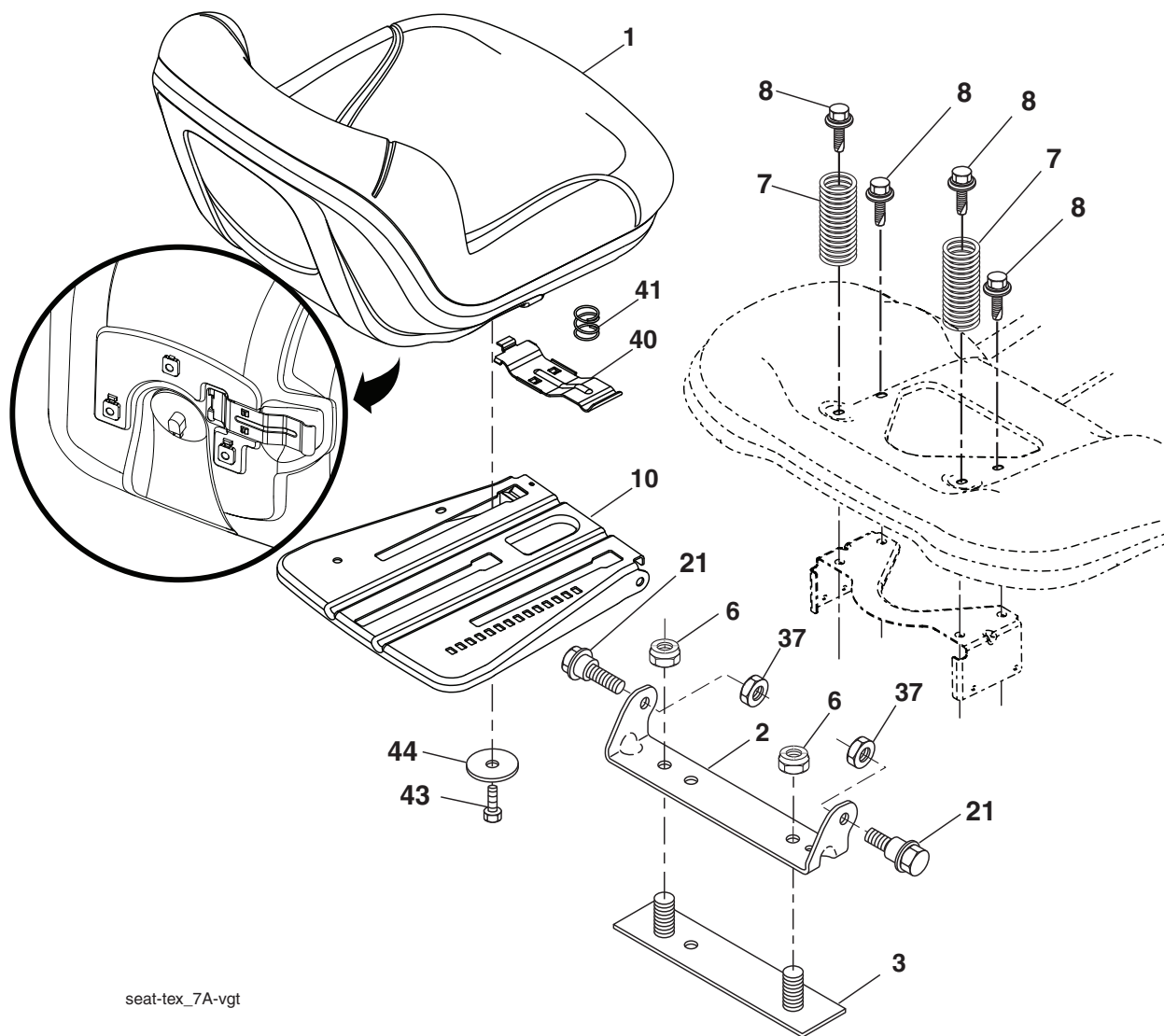

seat-tex_7A-vgt

KEY NO.	PART NO.	DESCRIPTION
1	532 19 75-11	Seat
2	532 18 01-66	Bracket Pivot Fender
3	532 14 06-75	Strap, Asm Fender
6	873 80 06-00	Nut, Lock w/Ins. 3/8-16 unc
7	532 12 41-81	Spring, Seat Cprsn
8	532 17 18-77	Bolt 5/16-18 unc x 3/4 w/Sems
10	532 19 69-77	Pan, Seat
21	532 17 18-52	Bolt, Shoulder 5/16-18

KEY NO.	PART NO.	DESCRIPTION
37	873 80 05-00	Nut, Lock 5/16-18 unc
40	532 19 76-61	Handle Slide Seat
41	532 19 82-00	Spring Latch Seat
43	874 76 06-12	Bolt 3/8-16 x 3/4
44	819 13 38-12	Washer 13/32 x 2-3/8 x 12 Ga.

NOTE: All component dimensions given in U.S. inches
1 inch = 25.4 mm

**TRACTOR - MODEL NO. M155107H (96041001004), PRODUCT NO. 960 41 00-10
DECALS**

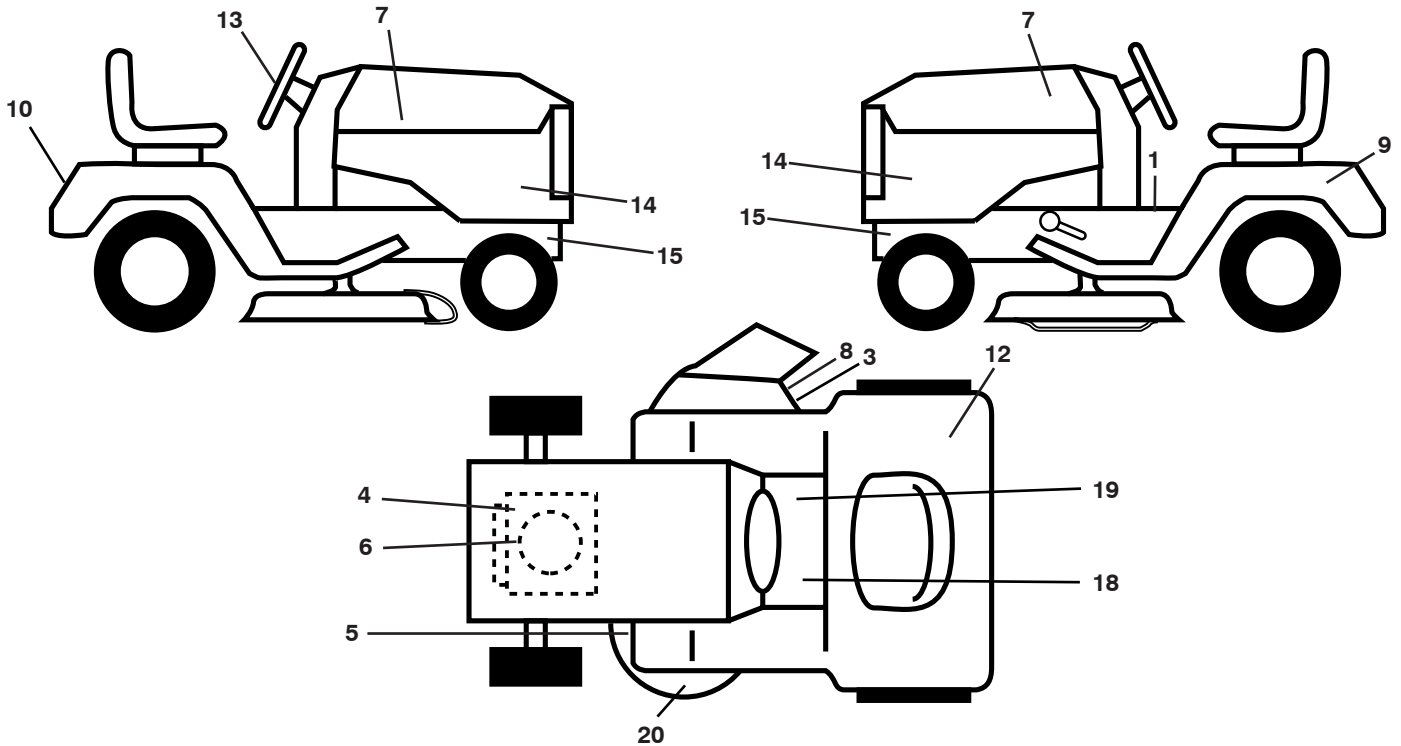

KEY NO.	PART NO.	DESCRIPTION
1	532 40 03-89	Decal, Warning Sym.
3	532 19 63-57	Decal, Warning
4	532 19 68-41	Decal, Warning Engine
5	532 16 03-96	Decal, V-Belt Sch.
6	532 43 10-95	Decal, Eng. HP
7	532 43 12-35	Decal, Hood LH/RH
8	532 18 21-66	Decal, Cutfinger
9	532 14 50-05	Decal, Battery Dnge/Poi
10	532 40 90-01	Decal, Fender
12	532 18 04-32	Decal, Fender DB/CE
13	532 42 42-36	Decal, Steering Whl
14	532 43 35-73	Decal, Panel Side
15	532 15 97-36	Decal, Hot Muffler

KEY NO.	PART NO.	DESCRIPTION
18	532 15 97-37	Decal, Clutch/Brake
19	532 14 08-37	Decal, Saddle Brake Parking
20	532 13 49-99	Decal, Enviro
--	532 16 69-60	Decal, Bypass
--	532 16 25-98	Decal, Load Limit
--	532 40 95-05	Pad, Footrest, LH
--	532 41 12-73	Pad, Footrest, RH
--	532 43 32-99	Manual, Oper Euro
--	532 43 33-00	Manual, Oper Scan
--	532 43 33-01	Manual, Oper E-Bloc
--	532 43 33-02	Manual, Oper Baltic
--	532 43 33-03	Manual, Parts

WHEELS AND TIRES

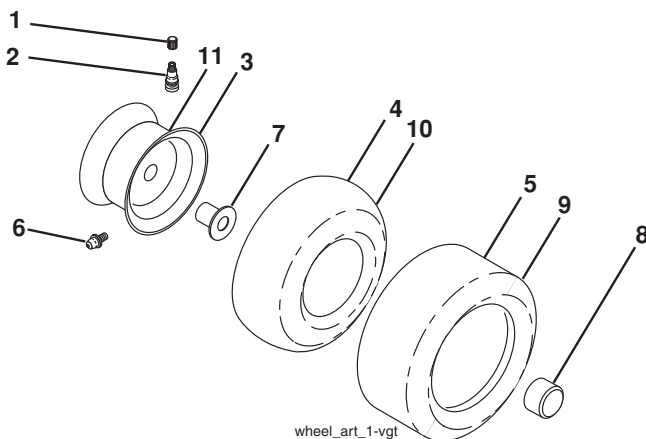

KEY NO.	PART NO.	DESCRIPTION
1	532 05 91-92	Cap, Valve, Tire
2	532 06 51-39	Stem, Valve
3	532 12 51-21	Rim Assembly, Front
4	532 05 99-04	Tube, Front (Service Item Only)
5	532 10 62-22	Tire, Front
6	532 12 49-57	Fitting, Grease (Front Wheel Only)
7	532 12 49-59	Bearing, Flange (Front Wheel Only)
8	532 17 50-39	Cap, Axle (Front Wheel Only)
9	532 13 84-68	Tire, Rear
10	532 12 49-26	Tube, Rear (Service Item Only)
11	532 12 51-22	Rim Assembly, Rear
--	532 14 43-34	Sealant, Tire (10 oz. Tube)

NOTE: All component dimensions given in U.S. inches
1 inch = 25.4 mm

TRACTOR - MODEL NO. M155107H (96041001004), PRODUCT NO. 960 41 00-10 MOWER DECK

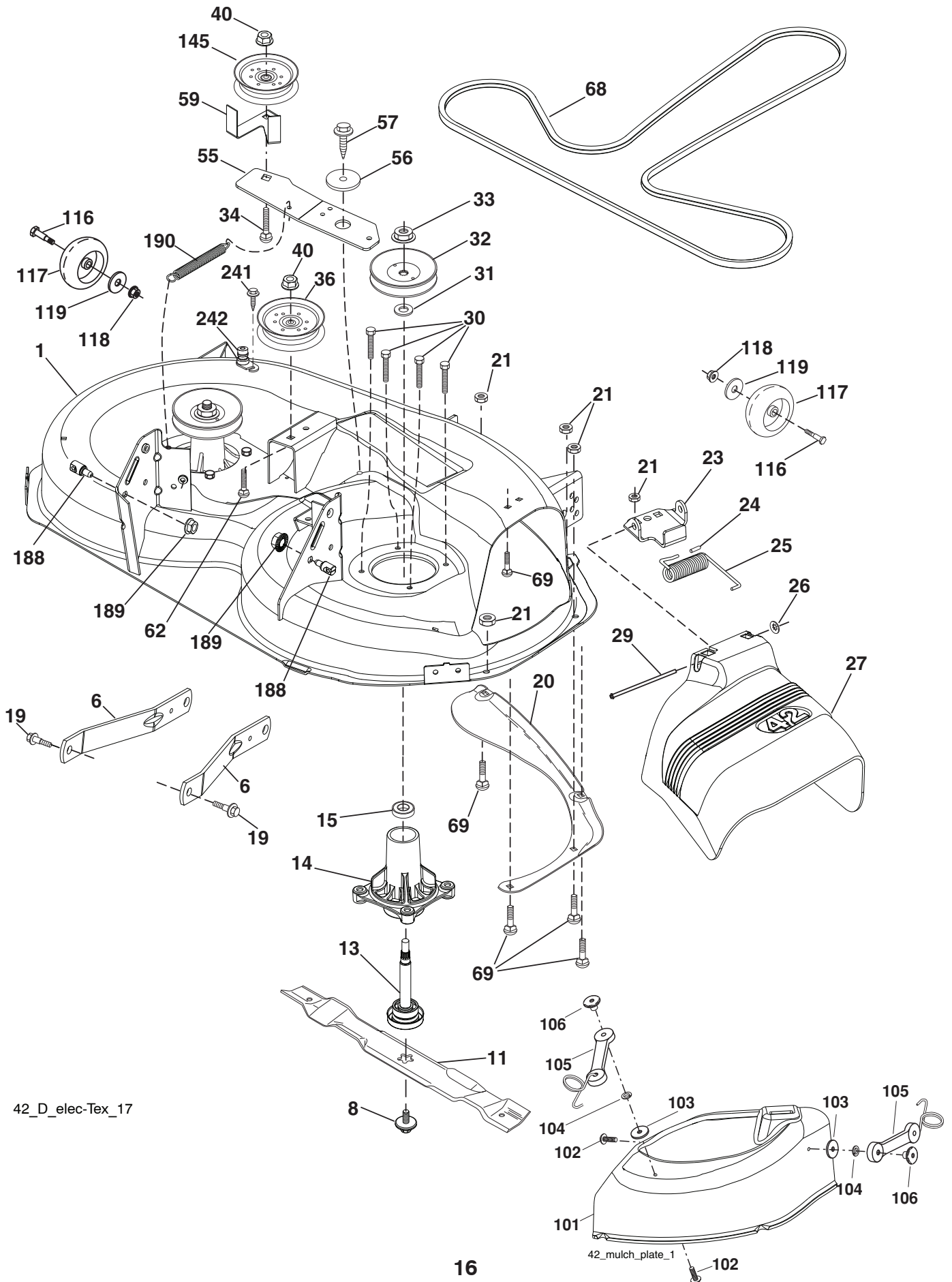

**TRACTOR - MODEL NO. M155107H (96041001004), PRODUCT NO. 960 41 00-10
MOWER DECK**

KEY NO.	PART NO.	DESCRIPTION	KEY NO.	PART NO.	DESCRIPTION
1	532 19 64-95	Mower Housing	59	532 14 10-43	Guard, Tuv Idler
6	532 19 51-86	Arm Suspension	62	872 11 06-16	Bolt RDHD 3/8-16 unc x 2
8	532 19 30-03	Bolt/Washer Asm 7/16-20 unf	68	532 14 49-59	V-Belt
11	532 13 41-49	Blade	69	872 14 05-05	Bolt
13	532 19 28-72	Shaft Assembly, Mandrel	97	532 17 85-15	Washer, Flat Hardened
14	532 18 72-81	Housing, Mandrel	101	532 19 31-07	Cover Mulching
15	532 11 04-85	Bearing, Ball, Mandrel	102	871 08 10-10	Screw 10-24 x 5/8
16	532 17 44-93	Stripper, Mower Deck	103	819 06 12-16	Washer #10
19	532 19 65-39	Bolt, Shoulder	104	810 07 10-00	Washer Lock #10
20	532 15 97-70	Baffle, Vortex	105	532 16 07-93	Latch Asm
21	873 68 05-00	Nut, Crownlock 5/16-18 unc	106	532 12 50-04	Nut Weld
23	532 19 25-57	Bracket, Deflector	116	532 12 48-42	Bolt, Shoulder
24	532 10 53-04	Cap, Sleeve	117	532 18 86-06	Wheel, Gauge
25	532 19 70-26	Spring, Torsion, Deflector	118	873 90 06-00	Nut, Lock 3/8-16 unc
26	532 11 04-52	Nut, Push	119	819 12 14-14	Washer 3/8 x 7/8 x 14 Ga.
27	532 40 30-04	Shield, Deflector	145	532 19 31-97	Pulley, Idler, Primary
29	532 13 14-91	Rod, Hinge	188	532 19 51-61	Stud Fastener
30	532 17 39-84	Screw Thdrol Rolling Wsh Hd	189	873 90 05-00	Nut Lock Hex Flange
31	532 18 76-90	Washer, Spacer	190	532 19 72-51	Spring Mower Drive Electric
32	532 15 35-35	Pulley, Mandrel	241	532 15 29-27	Screw #10-325 3/8
33	532 40 02-34	Nut, Toplock, Flanged	242	532 41 55-98	Port Washout
34	872 11 06-12	Bolt Carr Sh. 3/8-16 x 1-1/2 Gr. 5	--	532 19 28-70	Mandrel Assembly (Includes housing, shaft and shaft hard ware only-pulley not included)
36	532 19 73-79	Pulley Idler	--	532 43 33-08	Replacement Mower, Complete
40	873 90 06-00	Nut, Lock Flg. 3/8-16 unc			
55	532 43 71-10	Arm, Idler			
56	532 19 90-92	Spacer, Retainer			
57	817 00 06-16	Screw 3/8-16 x 1			

NOTE: All component dimensions given in U.S. inches
1 inch = 25.4 mm

**TRACTOR - MODEL NO. M155107H (96041001004), PRODUCT NO. 960 41 00-10
MOWER LIFT**

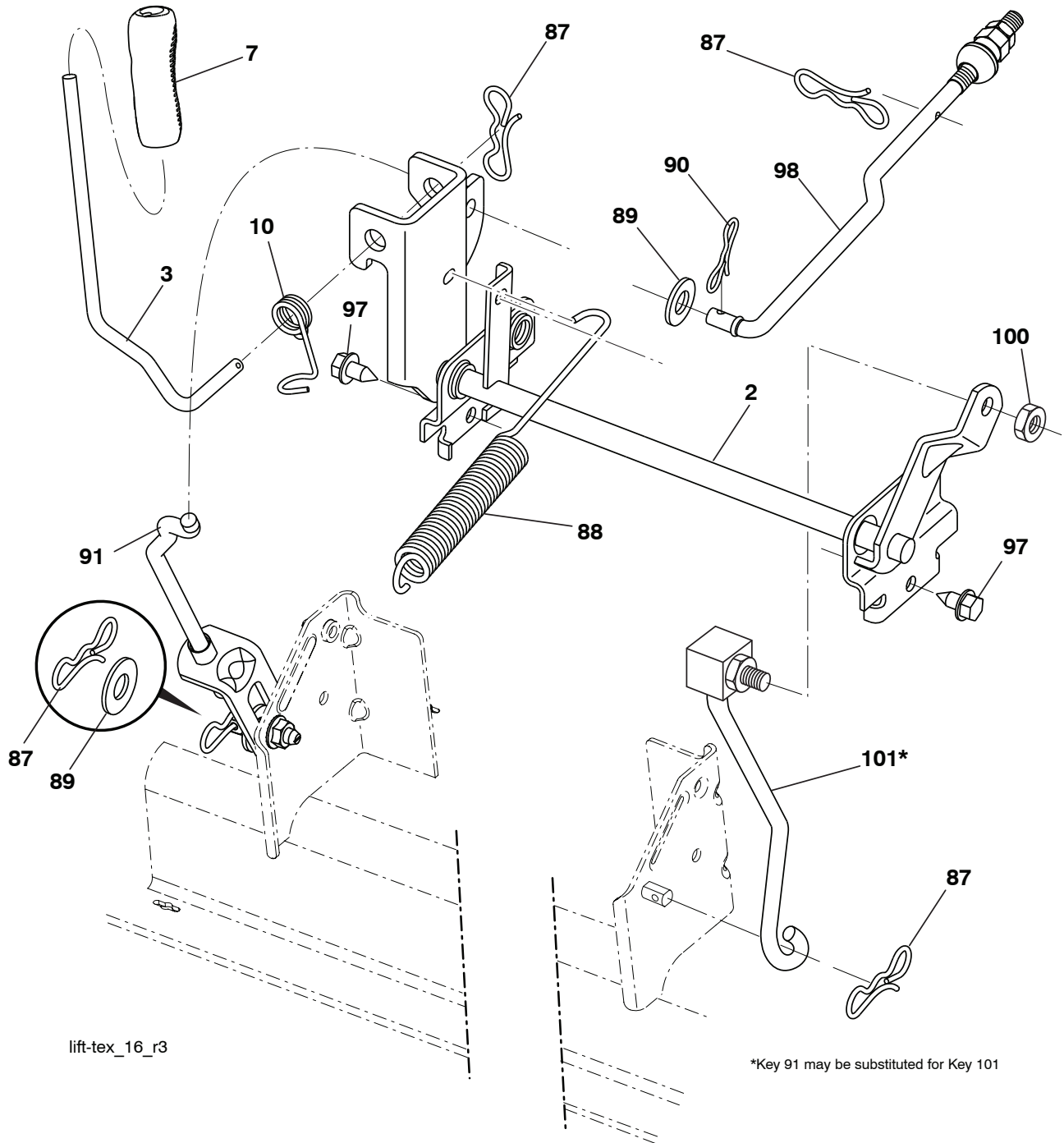

KEY NO.	PART NO.	DESCRIPTION
2	532 42 20-27	Shaft Asm., Lift
3	532 19 52-31	Lever Asm., Lift
7	532 41 17-42	Grip, Lever
10	532 19 63-14	Spring Torsion
87	532 19 42-09	Pin Cotter 7/16 Bow Tie Lock
88	532 41 07-10	Spring Lift Assist
89	819 19 19-12	Washer Clear Zinc
90	532 19 42-08	Pin Cotter 5/16 Bow Tie Lock

KEY NO.	PART NO.	DESCRIPTION
91	532 19 51-81	Link Lift Susp Mower Rear
97	817 00 06-12	Screw 3/8-16 x 3/4
98	532 19 52-70	Link Lift Susp. Front Mower
100	873 93 06-00	Nut Centerlock 3/8-16
101	532 40 70-03	Link Asm. Lift FXD

NOTE: All component dimensions given in U.S. inches
1 inch = 25.4 mm

SERVICE NOTES

