

# **ILLUSTRATED PARTS LIST**

**MFG. ID NO. 96041000903**

**CUSTOMER CATALOG NO. M13597H**

**PRODUCT NO. 960 41 00-09**

**TRACTOR - - MODEL NO. M13597H (96041000903), PRODUCT NO. 960 41 00-09  
DECALS 27**

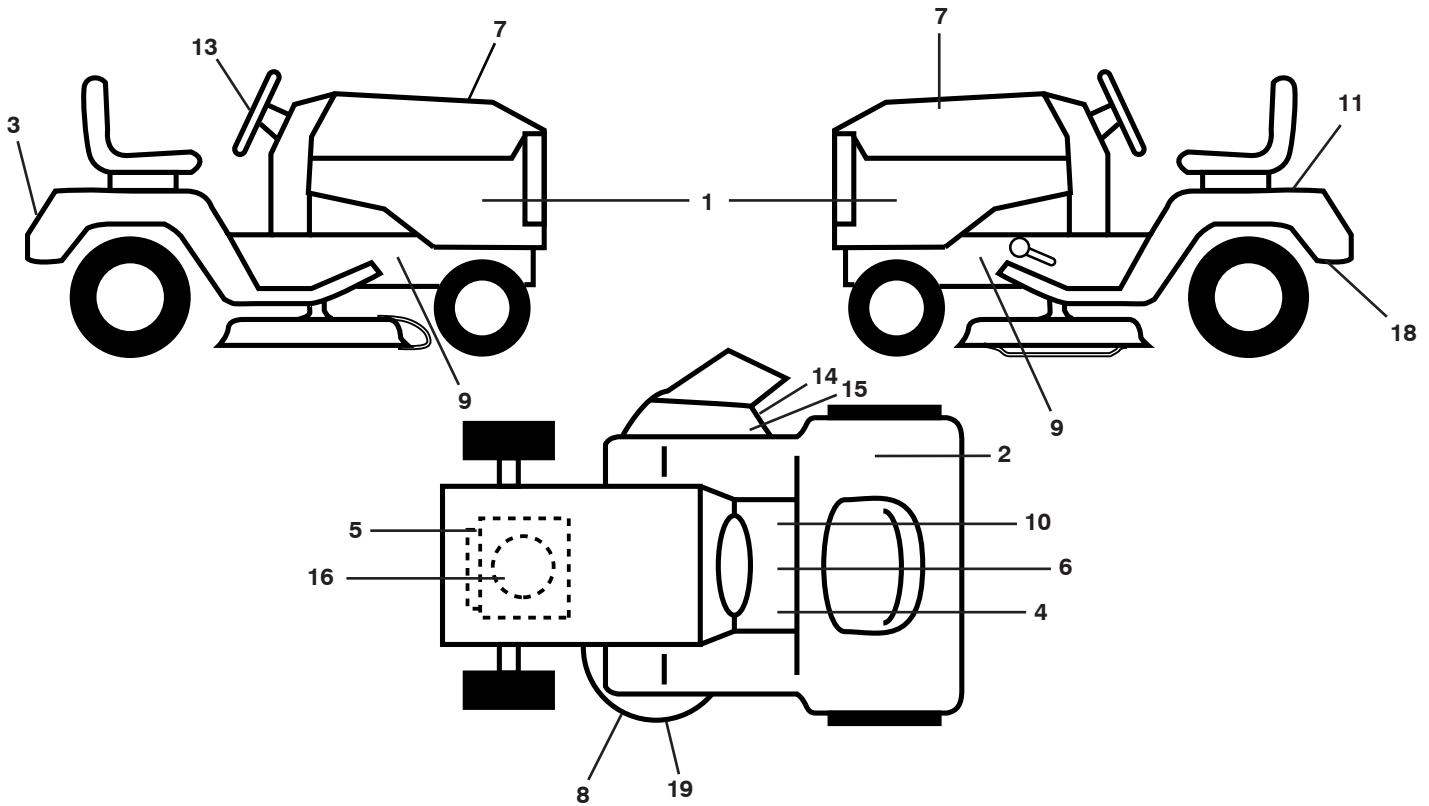

KEY PART NO.	PART NO.	DESCRIPTION
1	532 40 89-98	Decal, Panel SD
2	532 18 04-32	Decal, Fender 100 DB/CE
3	532 40 89-99	Decal, Fender
4	532 15 97-37	Decal, Brake/Clutch
5	532 41 79-28	Decal, Engine HP
6	532 40 03-89	Decal, Warning
7	532 43 11-71	Decal, Hood RH/LH
8	532 19 43-02	Decal, V-Belt Schematic
9	532 15 97-36	Decal, Chassis Hot Muffler
10	532 14 08-37	Decal, Saddle Brake Parking
11	532 14 50-05	Decal, Battery Dnge/Poi
13	532 40 82-02	Decal, Whl Str
14	532 18 21-66	Decal, Cutfinger

KEY PART NO.	PART NO.	DESCRIPTION
15	532 19 63-57	Decal, Deflect Wrn
16	532 19 68-41	Decal, Warning Engine
18	532 16 25-98	Decal, Drawbar
19	532 13 49-99	Decal, Mower Enviro
--	532 40 82-04	Decal, Grill Domed Logo
--	532 16 69-60	Decal, Bypass Fender
--	532 40 95-05	Pad, Footrest, LH
--	532 41 12-73	Pad, Footrest, RH
--	532 40 82-78	Manual, Operator's (Euro)
--	532 40 82-79	Manual, Operator's (Scand)
--	532 41 19-69	Manual, Operator's (E-Bloc)
--	532 41 19-70	Manual, Operator's (Baltic)

**WHEELS & TIRES**

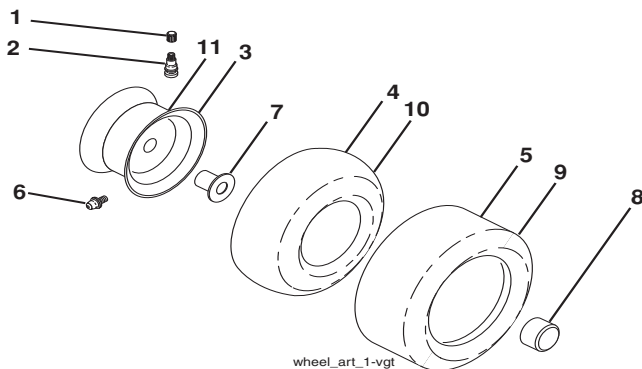

KEY PART NO.	PART NO.	DESCRIPTION
1	532 05 91-92	Cap, Valve, Tire
2	532 06 51-39	Stem, Valve
3	532 12 51-21	Rim Assembly, Front 15 x 6.0-6
4	532 05 99-04	Tube, Front
5	532 10 62-22	Tire, Front
6	532 12 49-57	Fitting, Grease
7	532 12 49-59	Bearing, Flange
8	532 17 50-39	Cap, Axle (Front Wheel Only)
9	532 12 46-35	Tire, Rear 18 x 8.5-8
10	532 12 49-26	Tube, Rear
11	532 12 51-22	Rim Assembly, Rear 8"
--	532 14 43-34	Sealant, Tire (10 oz. Tube)

**NOTE:** All component dimensions given in U.S. inches  
1 inch = 25.4 mm

# TRACTOR - - MODEL NO. M13597H (96041000903), PRODUCT NO. 960 41 00-09

## SCHEMATIC 38

SCH11

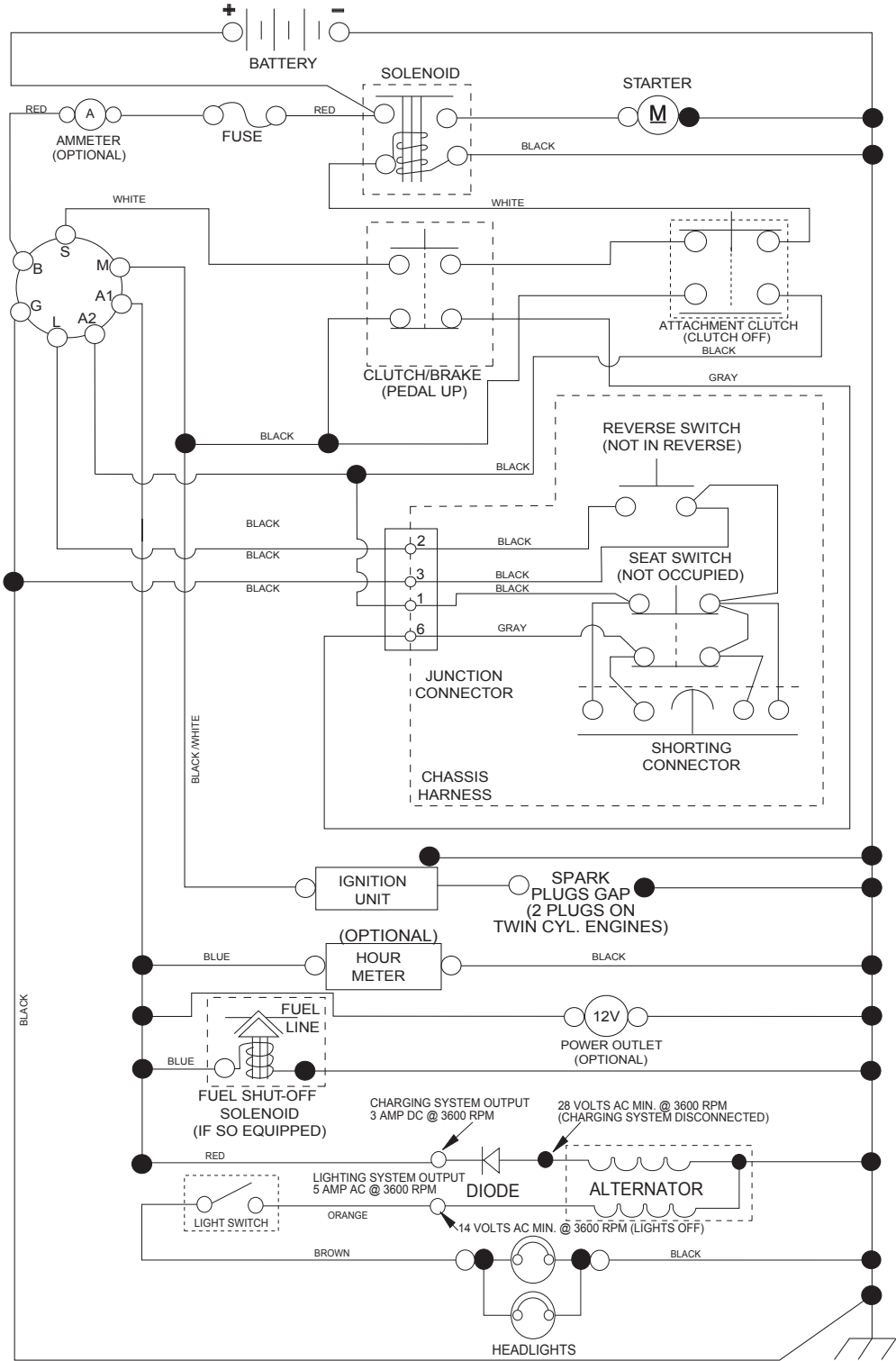

**NOTE**  
 YOUR TRACTOR IS EQUIPPED WITH A SPECIAL ALTERNATOR SYSTEM. THE LIGHTS ARE NOT CONNECTED TO THE BATTERY, BUT HAVE THEIR OWN ELECTRICAL SOURCE. BECAUSE OF THIS, THE BRIGHTNESS OF THE LIGHTS WILL CHANGE WITH ENGINE SPEED. AT IDLE THE LIGHTS WILL DIM. AS THE ENGINE IS SPEEDED UP, THE LIGHTS WILL BECOME THEIR BRIGHTEST.

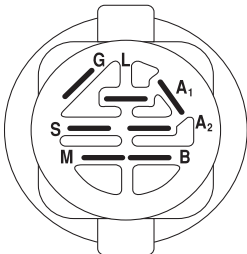

IGNITION SWITCH

POSITION	CIRCUIT	"MAKE"
OFF	M+G+A1	
RUN/OVERRIDE	B+A1	
RUN	B+A1	L+A2
START	B + S + A1	

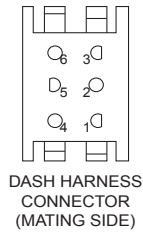
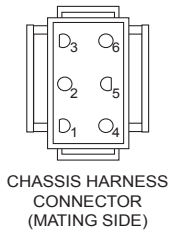

WIRING INSULATED CLIPS  
 NOTE: IF WIRING INSULATED CLIPS WERE REMOVED FOR SERVICING OF UNIT, THEY SHOULD BE RE-INSTALLED TO PROPERLY SECURE YOUR WIRING.



TRACTOR - - MODEL NO. M13597H (96041000903), PRODUCT NO. 960 41 00-09  
ELECTRICAL **32**

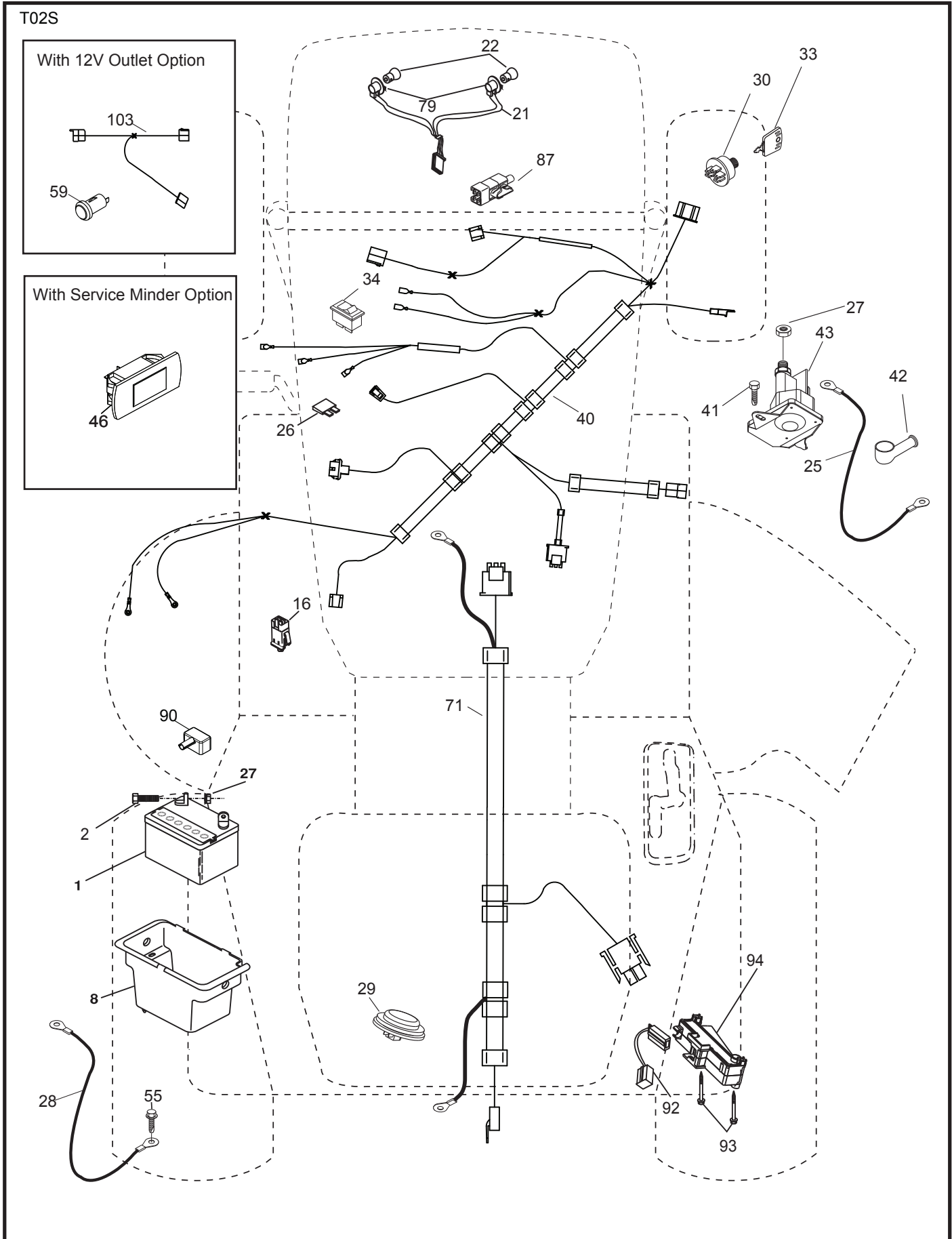

**TRACTOR - - MODEL NO. M13597H (96041000903), PRODUCT NO. 960 41 00-09  
ELECTRICAL 32**

KEY NO.	PART NO.	DESCRIPTION
1	532 16 34- 65	Battery
2	874 76 04-12	Bolt Hex Hd 1/4-20 unc x 3/4
8	532 19 32-28	Box Battery
16	532 17 61-38	Switch Interlock Push-In
21	532 18 37-59	Harness Socket Light w/4152J
22	532 00 41-52	Bulb Light
25	532 41 28-94	Cable Starter
26	532 17 51-58	Fuse
27	873 51 04-00	Nut Keps Hex 1/4-20 unc
28	532 19 88-85	Cable, Ground
29	532 40 15-45	Switch, Seat
30	532 19 33-50	Switch, Ign
33	532 41 19-35	Key/Chain
34	532 11 07-12	Switch Light/Reset
40	532 40 10-98	Harness Ign. Dash
41	817 72 04-08	Screw Thd Cut 1/4-20 x 1/2
42	532 13 15-63	Cover, Terminal
43	532 19 25-07	Solenoid
55	817 06 05-12	Screw Thdrol 5/16-18 x 3/4 TYTT
71	532 40 04-49	Harness Ign.
79	532 17 52-42	Bulbholder Asm. Incandescent
87	532 19 78-02	Switch Interlock
90	532 40 07-25	Cover Terminal Battery
92	532 19 66-15	Harness Pigtail
93	532 19 25-40	Screw Plastite 10-14 x 2.0
94	532 19 18-34	Module Reverse ROS

**NOTE:** All component dimensions given in U.S. inches  
1 inch = 25.4 mm

TRACTOR - - MODEL NO. M13597H (96041000903), PRODUCT NO. 960 41 00-09  
CHASSIS AND ENCLOSURES **39**

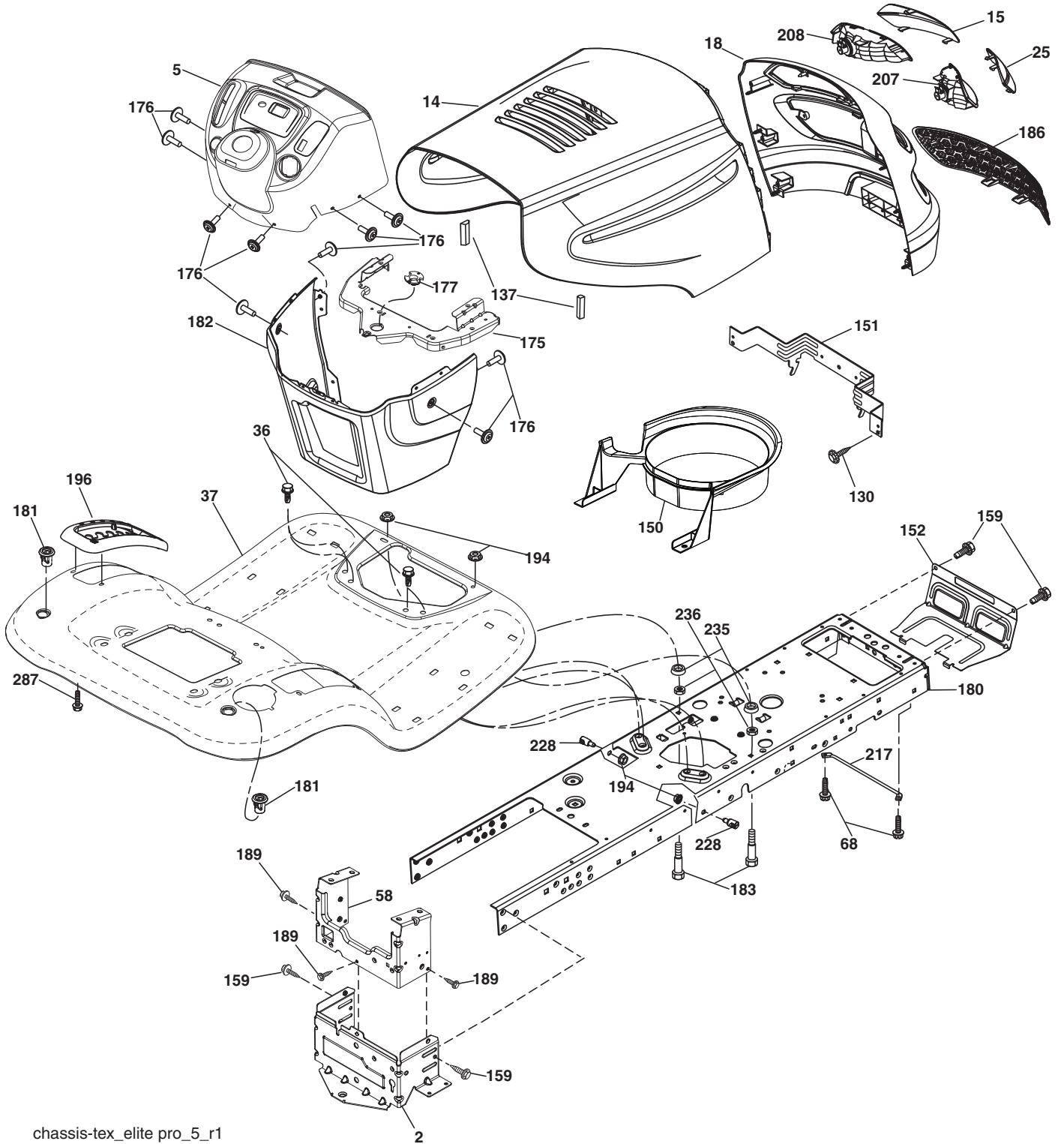

chassis-tex\_elite pro\_5\_r1

**TRACTOR - - MODEL NO. M13597H (96041000903), PRODUCT NO. 960 41 00-09  
CHASSIS AND ENCLOSURES 39**

<b>KEY NO.</b>	<b>PART NO.</b>	<b>DESCRIPTION</b>
2	532 41 22-82	Drawbar Lower
5	532 41 12-79	Dash
14	532 18 65-80	Hood
15	532 18 97-54	Lens LH
18	532 40 82-98	Grille
25	532 18 97-55	Lens RH
36	817 06 05-12	Screw 5/16-18 x 3/4
37	532 42 41-80	Fender
58	532 41 22-80	Drawbar Upper
68	817 49 05-08	Screw THDROL 5/16-18 x 1/2
130	532 41 63-58	Screw #10 x 0.750.BOS
137	532 18 49-21	Bumper Dash
150	532 18 44-91	Duct Intake Air
151	532 40 78-07	Bracket Pivot
152	532 19 43-29	Shield Browning
159	817 00 06-12	Screw 3/8-16 x 3/4
175	532 19 32-43	Crossmember
176	532 40 07-76	Screw 10-24 x 5/8
177	532 19 52-28	Bushing Steering
180	532 19 42-60	Chassis
181	532 40 47-96	Bushing Mtg. Fender Crgo
182	532 19 30-57	Dash Lower
183	874 78 05-20	Bolt 5/16-18 unc x 1-1/4
186	532 18 97-53	Insert Grille
189	817 00 05-12	Screw 5/16-18 x 3/4
194	873 90 05-00	Nut Lock Hex Flange 5/16-18
196	532 41 45-81	Console Asm. Deck Lift
207	532 18 38-33	Bezel RH
208	532 18 38-32	Bezel LH
217	532 40 91-67	Rod Pivot Hood
228	532 19 51-61	Stud Fastener
235	532 40 61-29	Spacer Fender
236	873 93 05-00	Nut Lock 5/16-18 unc
287	817 60 04-06	Screw Hex 1/4-20 x 3/8

**NOTE:** All component dimensions given in U.S. inches  
1 inch = 25.4 mm

TRACTOR - - MODEL NO. M13597H (96041000903), PRODUCT NO. 960 41 00-09  
 DRIVE **40**

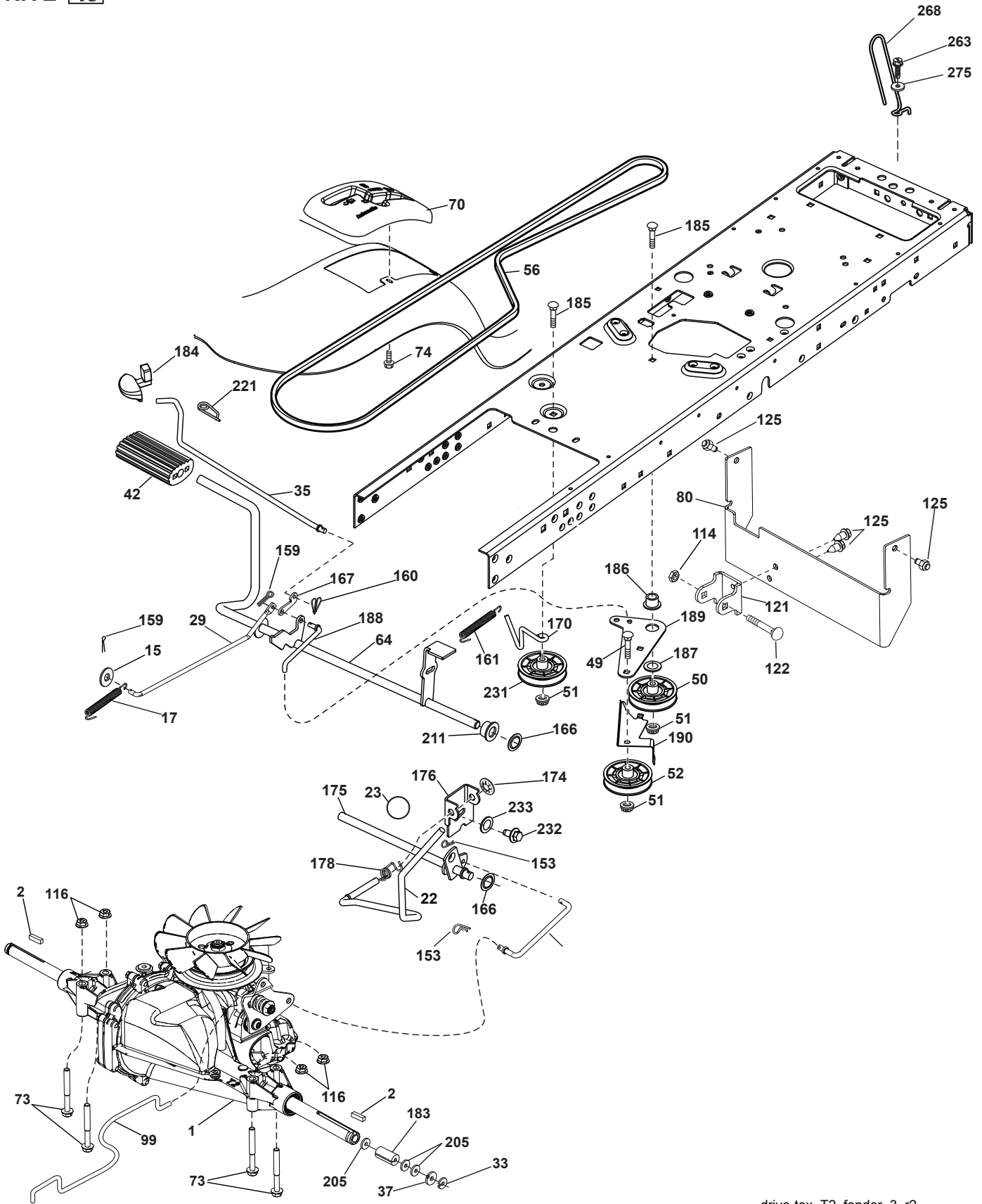

drive-tex\_T2\_fender\_3\_r2



**TRACTOR - - MODEL NO. M13597H (96041000903), PRODUCT NO. 960 41 00-09  
DRIVE **40****

KEY NO.	PART NO.	DESCRIPTION	KEY NO.	PART NO.	DESCRIPTION
1	---	Transaxle, Hydro T2-AABC-1X1A-1GX1 (Internal Parts Not Available)	161	532 10 57-09	Spring, Return, Clutch
2	532 12 35-83	Key	165	532 19 62-12	Bushing
15	819 13 13-16	Washer 13/32 x 13/16 x 16 Ga.	166	532 19 72-90	Nut Push .625
17	532 19 72-96	Spring, Brake	167	532 40 52-57	Latch Brake Parking
22	532 19 76-60	Rod Shift	170	532 41 34-30	Keeper Belt Centerspan
23	532 41 14-00	Knob	174	532 19 72-89	Nut Push
29	532 40 83-91	Rod, Brake	175	532 40 85-39	Shaft Asm
33	812 00 00-01	Ring E	176	532 19 62-14	Asm Clevis Rod Shift
35	532 19 77-22	Rod, Brake, Park	178	532 19 74-56	Spring Shift
37	532 12 17-49	Washer 25/32 x 1-1/4 x 16 Ga.	183	532 15 69-72	Spacer Axle
42	532 12 48-72	Cover, Foot Pedal	184	532 41 12-89	Handle Parking Brake
49	872 11 06-14	Bolt	185	872 11 06-22	Bolt
50	532 19 43-27	Pulley Idler Flat	186	532 19 43-21	Spacer Retainer
51	873 90 06-00	Lock Nut 3/8-16	187	819 13 32-10	Washer
52	532 19 43-26	Idler V-Groove 910" Offset	188	532 19 43-23	Link Clutch Ground Drive
56	532 12 59-07	V-Belt, Drive	189	532 19 43-17	Bellcrank Ground Drive
64	532 19 62-00	Shaft Asm. Pedal Brake Control	190	532 19 43-18	Keeper Bellcrank Ground Drive
70	532 41 13-29	Console Shift	205	532 12 17-48	Washer 25/32 x 1-5/8 x 16 Ga.
73	874 49 05-44	Bolt Hex Flghd 5/16-18 Gr. 5	221	532 40 31-87	Retainer Spring Clip Handle
74	532 14 24-32	Screw Hex Wsh Hi-Lo 1/4 x 1/2 unc	231	532 40 72-87	Idler V-Groove 1.688 Offset
80	532 40 83-93	Strap Torque	232	874 78 07-16	Bolt Fin Hex 7/16-14 x 1
99	532 40 84-18	Rod Asm. Bypass	233	532 40 52-96	Washer Serrated
114	873 80 05-00	Nut Lock Hex w/INS 5/16-18 unc	263	817 00 06-12	Screw Hex Wsh Thdrol 3/8-16 x 3/4
116	873 90 05-00	Nut Lock Hex Flange 5/16-18	268	532 18 24-02	Guard Muffler
121	532 17 56-11	Bracket Strap Torque	275	819 13 16-14	Washer 13/32 x 1 x 14
122	872 01 05-20	Bolt 5/16-18 x 2.50	279	532 40 85-38	Link Shift
125	817 00 05-12	Screw 5/16-18 x 3/4			
153	532 12 47-88	Retainer Spring 1"			
159	876 02 04-12	Pin Cotter 1/8 x 3/4			
160	532 16 94-84	Retainer Clip			

**NOTE:** All component dimensions given in U.S. inches  
1 inch = 25.4 mm

TRACTOR - - MODEL NO. M13597H (96041000903), PRODUCT NO. 960 41 00-09  
ENGINE 24

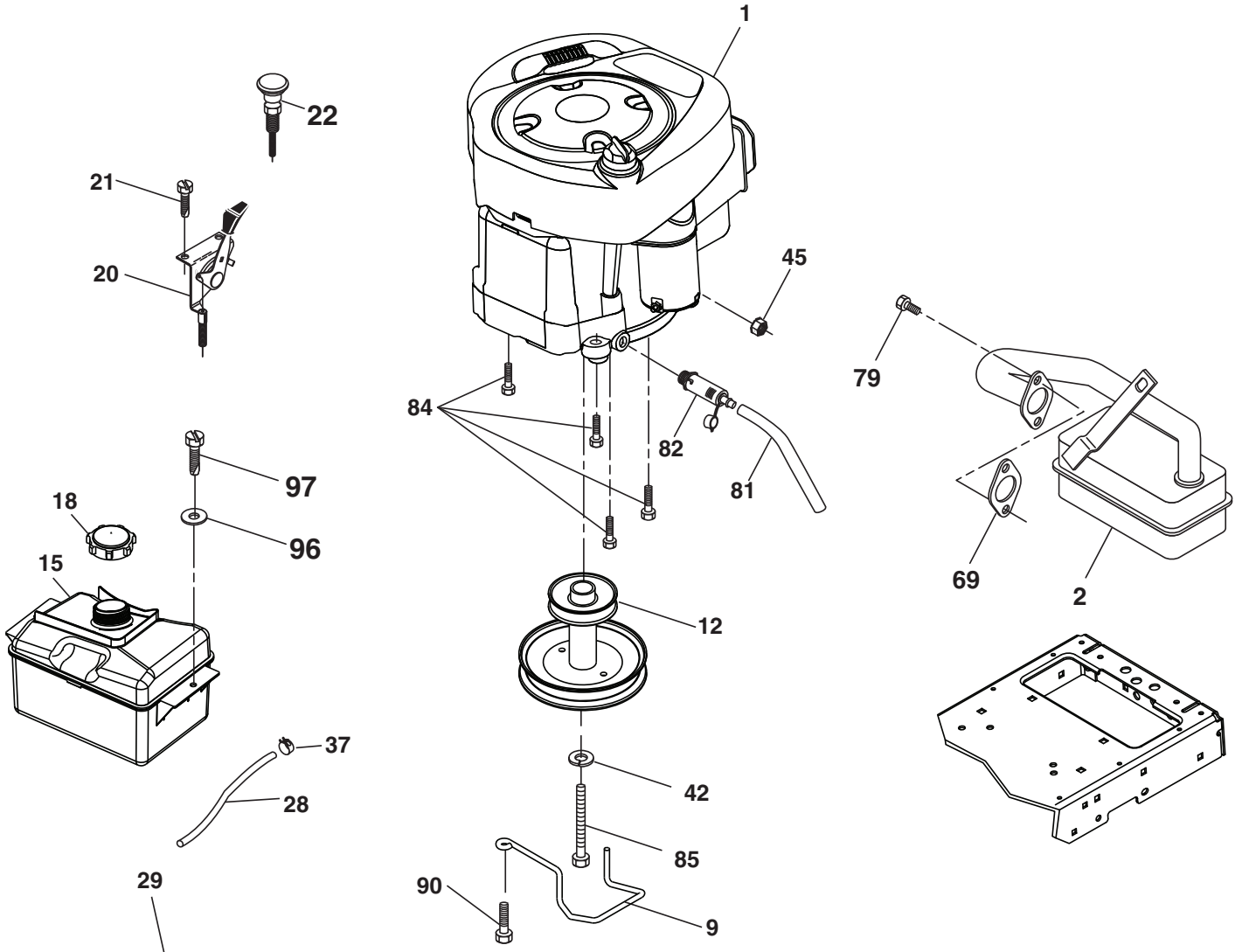

**OPTIONAL EQUIPMENT**  
**Spark Arrester**

engine-tex\_BS\_8

**TRACTOR - - MODEL NO. M13597H (96041000903), PRODUCT NO. 960 41 00-09  
ENGINE 24**

KEY NO.	PART NO.	DESCRIPTION
1	-----	Engine B&S Model No. 21B807
2	532 17 97-58	Muffler
9	532 19 43-19	Keeper Belt Engine
12	532 40 19-85	Pulley Engine
15	532 40 75-45	Tank Fuel
18	532 19 77-25	Cap Asm
20	532 41 17-24	Control Throttle/Choke
21	532 41 63-58	Screw #10 x 0.750.BOS
22	532 41 17-25	Control Choke
28	532 13 70-40	Fuel Line
29	532 13 71-80	Spark Arrester Kit
37	532 12 34-87	Clamp Hose
42	810 04 07-00	Washer Lock 7/16
45	873 51 04-00	Nut Keps Hex 1/4-20 unc
69	532 16 52-91	Gasket
79	532 19 23-34	Screw Socket Hd 5/16-18 x .75
81	532 14 84-56	Tube Drain Oil Easy
82	532 18 16-54	Plug Drain Oil
84	817 06 06-20	Screw 3/8-16 x 1-1/4
85	532 17 39-37	Bolt Hex 7/16-20 x 4 x Gr. 5-1.5
90	817 00 06-16	Screw 3/8-16 x 1.0
96	819 09 14-16	Washer 9/32 x 7/8 x 16 Ga.
97	817 67 04-12	Screw 1/4-20 x 3/4

**NOTE:** All component dimensions given in U.S. inches  
1 inch = 25.4 mm

**Engine Power Rating Information**

The gross power rating for individual gas engine models is labeled in accordance with SAE (Society of Automotive Engineers) code J1940 (Small Engine Power & Torque Rating Procedure), and rating performance has been obtained and corrected in accordance with SAE J1995 (Revision 2002-05). Torque values are derived at 3060 RPM; horsepower values are derived at 3600 RPM. Actual gross engine power will be lower and is affected by, among other things, ambient operating conditions and engine-to-engine variability. Given both the wide array of products on which engines are placed and the variety of environmental issues applicable to operating the equipment, the gas engine will not develop the rated gross power when used in a given piece of power equipment (actual “on-site” or net power). This difference is due to a variety of factors including, but not limited to, accessories (air cleaner, exhaust, charging, cooling, carburetor, fuel pump, etc.), application limitations, ambient operating conditions (temperature, humidity, altitude), and engine-to-engine variability. Due to manufacturing and capacity limitations, Briggs & Stratton may substitute an engine of higher rated power for this Series engine.

TRACTOR - - MODEL NO. M13597H (96041000903), PRODUCT NO. 960 41 00-09  
STEERING ASSEMBLY **41**

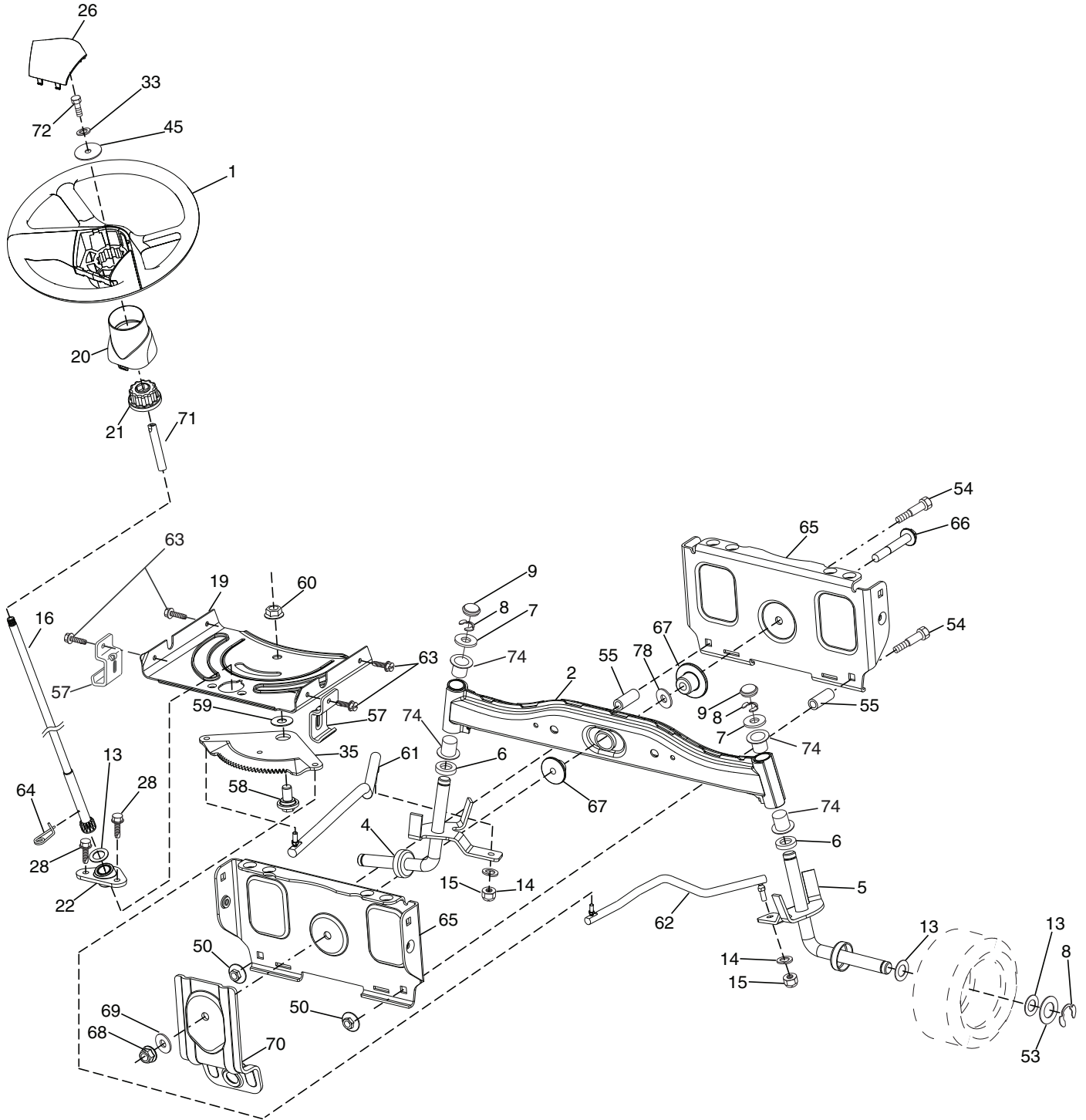

steering-tex\_LEGND2\_5

**TRACTOR - - MODEL NO. M13597H (96041000903), PRODUCT NO. 960 41 00-09  
STEERING ASSEMBLY 41**

KEY NO.	PART NO.	DESCRIPTION
1	532 19 45-95	Wheel, Steering
2	532 41 81-68	Axle Asm., Front
4	532 40 30-87	Spindle Asm., LH
5	532 40 30-88	Spindle Asm., RH
6	532 12 49-31	Washer Thrust
7	532 12 17-48	Washer 25/32 x 1-5/8 x 16 Ga.
8	812 00 00-29	Ring, Clip #T5304-75
9	532 12 12-32	Cap, Spindle
13	532 12 17-49	Washer 25/32 x 1-1/4 x 16 Ga.
14	810 04 06-00	Washer, Lock Hvy Hlcl Spr 3/8
15	873 54 06-00	Nut, Crown Lock 3/8-24 unf
16	532 19 60-74	Shaft Steering
19	532 19 47-29	Plate Steering
20	532 41 12-91	Boot, Steering
21	532 18 67-37	Adapter, Wheel Steering
22	532 19 48-45	Bushing, Strg. Blk
26	532 19 46-03	Insert, Wheel Steering
28	817 00 06-12	Screw 3/8-16 x 3/4
33	810 04 05-00	Washer Lock 5/16
35	532 19 47-32	Gear, Sector Plate
45	819 11 38-12	Washer 11/32 x 2-3/8 x 12 Ga.
50	873 90 06-00	Nut Lock Flg 3/8-16 unc
53	532 18 89-67	Washer Hardened .793x1.637x.060

KEY NO.	PART NO.	DESCRIPTION
54	874 76 06-36	Bolt Hex HS 3/8-16 unc x 2-1/4
55	532 41 47-36	Spacer Brace Axle
57	532 40 74-65	Bracket Upstop
58	532 19 47-47	Bolt Shoulder Sector Pivot CFM
59	532 19 47-48	Washer Thrust Sector Steering
60	873 97 10-00	Nut Flange Lock 5/8-11
61	532 19 47-40	Draglink, LH
62	532 19 47-41	Draglink, RH
63	817 00 05-12	Screw 5/16-18 x 3/4
64	532 19 98-49	Retainer Clip Spring Steering
65	532 19 47-34	Brace Axle Front
66	871 02 07-48	Bolt Hex Fghd 7/16-14 x 3 Serr
67	532 19 47-37	Bushing PM Front Axle
68	873 90 07-00	Nut Lock Flange 7/16-14 Gr. 5
69	532 19 91-62	Washer 1.5 x .505 x .118
70	532 19 61-97	Bracket Deck Susp. Front
71	532 19 60-75	Shaft Ext. Steering
72	874 78 05-72	Bolt 5/16-18 x 4.5 Gr. 5
74	532 12 49-37	Bearing
78	532 05 70-79	Washer Thrust

**NOTE:** All component dimensions given in U.S. inches  
1 inch = 25.4 mm

**TRACTOR - - MODEL NO. M13597H (96041000903), PRODUCT NO. 960 41 00-09**  
**MOWER DECK [44]**

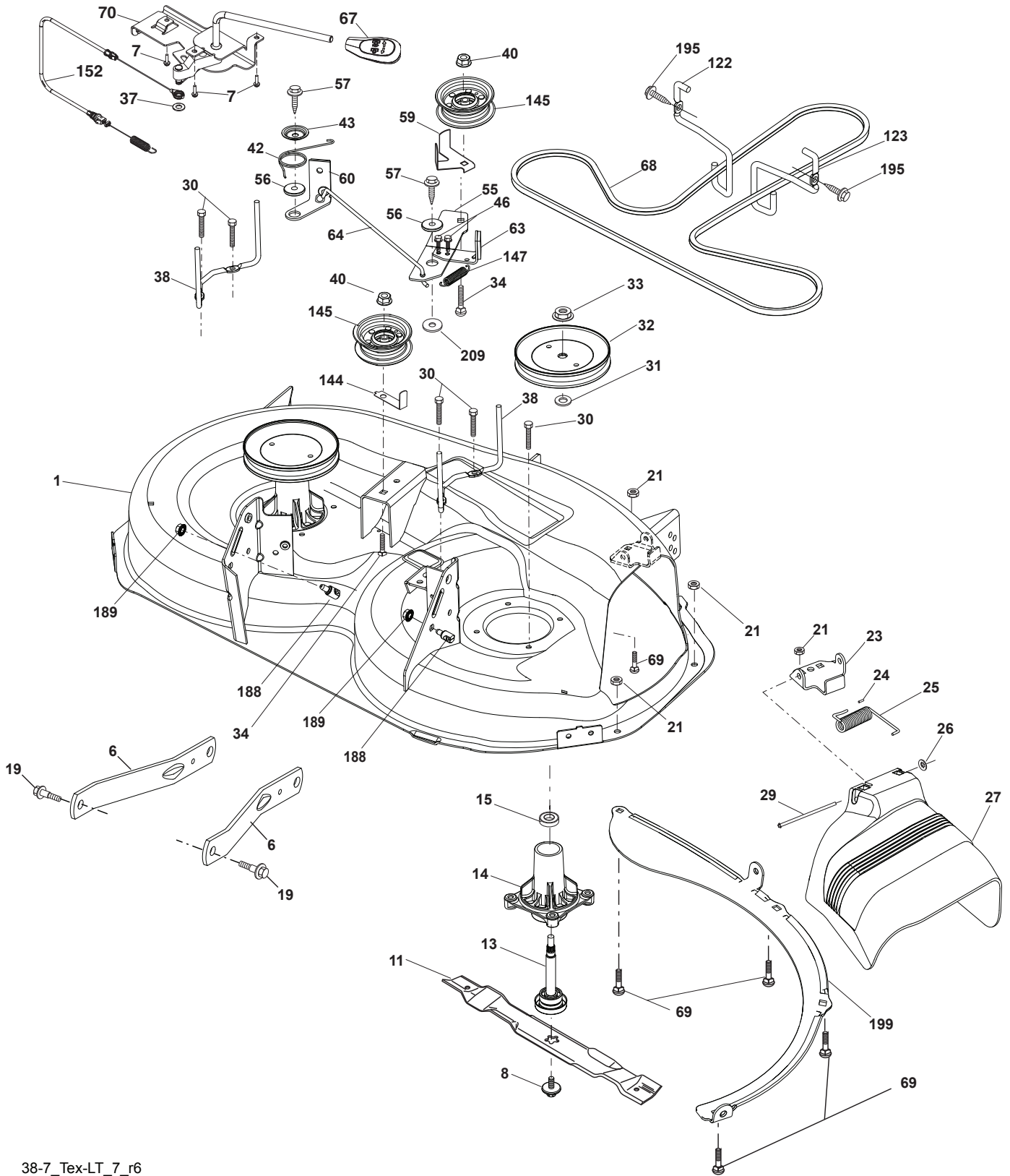

38-7\_Tex-LT\_7\_r6

**TRACTOR - - MODEL NO. M13597H (96041000903), PRODUCT NO. 960 41 00-09  
MOWER DECK 44**

KEY NO.	PART NO.	DESCRIPTION	KEY NO.	PART NO.	DESCRIPTION
1	532 19 42-51	Mower Housing	57	817 00 06-16	Screw 3/8-16 x 1
6	532 19 51-86	Arm Suspension	59	532 14 10-43	Guard, Tuv Idler
7	532 41 63-58	Screw #10 x 0.750 BOS	60	532 19 94-71	Arm Brake Mower
8	532 19 30-03	Bolt/Washer Asm 7/16-20 unf	63	532 19 94-70	Arm Brake Mower
11	532 19 39-57	Blade	64	532 19 97-90	Link Brake
13	532 19 28-72	Shaft Assembly, Mandrel	67	532 40 97-92	Handle Clutch Cable
14	532 18 72-81	Housing, Mandrel	68	532 40 83-81	V-Belt
15	532 11 04-85	Bearing, Ball, Mandrel	69	872 14 05-05	Bolt
19	532 19 65-39	Bolt, Shoulder	70	532 19 83-32	Clutch Asm Manual
21	873 68 05-00	Nut, Crownlock 5/16-18 unc	122	532 19 72-58	Keeper Belt Engine LH
23	532 19 25-57	Bracket, Deflector	123	532 19 72-59	Keeper Belt Engine RH
24	532 10 53-04	Cap, Sleeve	144	532 19 34-14	Keeper Belt
25	532 19 70-26	Spring, Torsion, Deflector	145	532 19 31-97	Pulley, Idler, Flat
26	532 11 04-52	Nut, Push	147	532 40 18-72	Spring Return
27	532 40 14-72	Shield, Deflector	152	532 40 87-14	Manual Clutch Cable
29	532 13 14-91	Rod, Hinge	188	532 19 51-61	Stud Fastener
30	532 17 39-84	Screw Thdrol Rolling Wsh Hd	189	873 90 05-00	Nut Lock Hex Flange
31	532 18 76-90	Washer, Spacer	195	817 00 06-12	Screw 3/8-16 x 3/4
32	532 19 97-89	Pulley, Mandrel	199	532 40 00-95	Baffle Vortex
33	532 40 02-34	Nut, Toplock, Flanged	209	819 13 32-10	Washer 13/32 x 2 x 10
34	872 11 06-12	Bolt Carr Sh. 3/8-16 x 1-1/2 Gr. 5	--	532 19 28-70	Mandrel Assembly (Includes housing, shaft assembly, and bearing only - pulley/nut/washer and blade bolt/washers not included)
37	819 13 13-16	Washer	--	532 40 04-22	Replacement Mower, Complete
38	532 19 95-41	Keeper Belt LH Mandrel			
40	873 90 06-00	Nut, Lock Flg. 3/8-16 unc			
42	532 19 84-10	Spring Torsion Brake			
43	532 19 72-56	Spring Torsion Retainer			
46	532 13 77-29	Screw 1/4-20 x 5/8			
55	532 19 72-49	Arm, Idler			
56	532 19 90-92	Spacer, Retainer			

**NOTE:** All component dimensions given in U.S. inches  
1 inch = 25.4 mm

**TRACTOR - - MODEL NO. M13597H (96041000903), PRODUCT NO. 960 41 00-09  
SEAT ASSEMBLY 42**

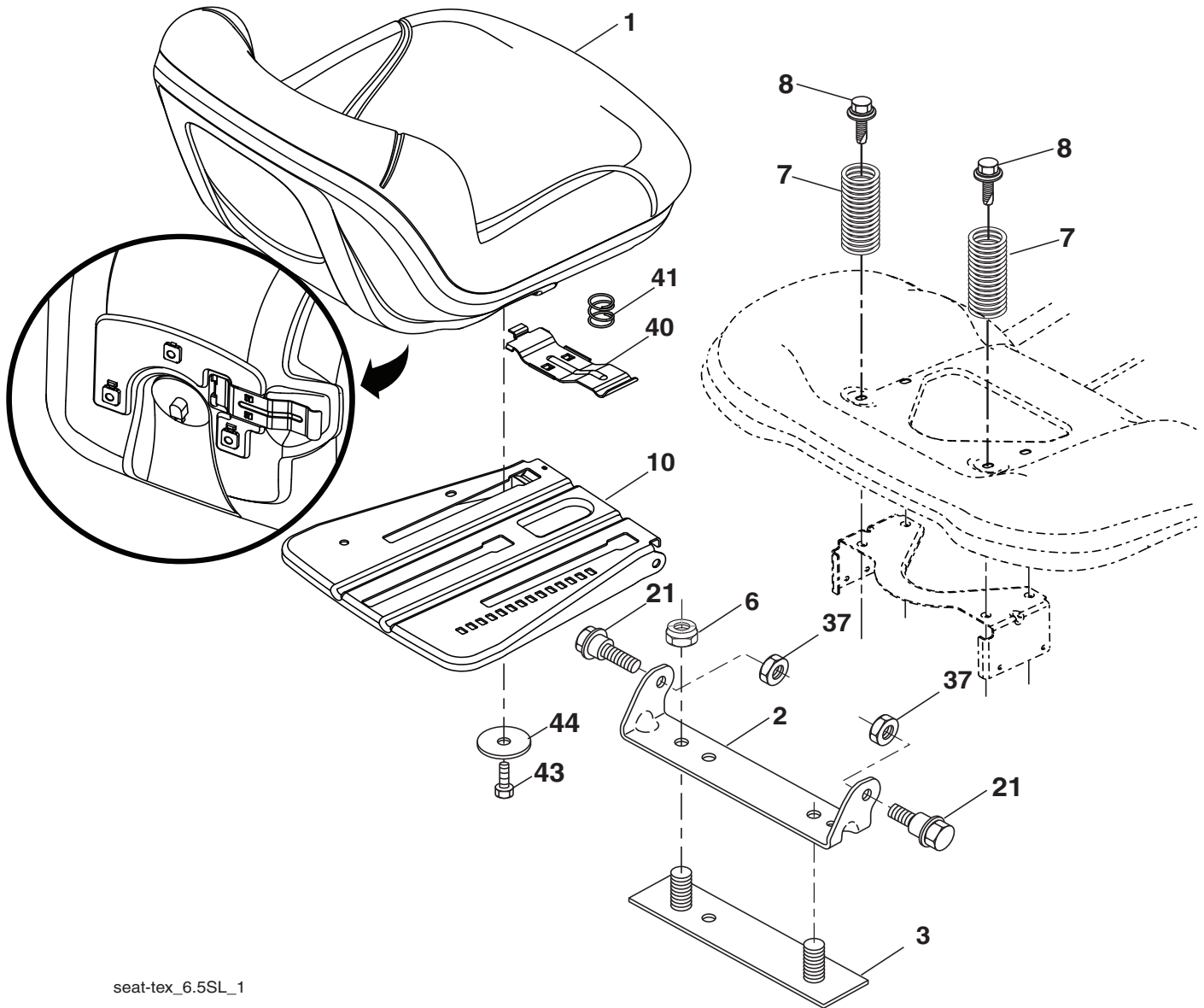

seat-tex\_6.5SL\_1

KEY NO.	PART NO.	DESCRIPTION
1	532 19 75-11	Seat
2	532 18 01-66	Bracket Pivot Fender
3	532 14 06-75	Strap, Asm Fender
6	873 80 06-00	Nut, Lock w/Ins. 3/8-16 unc
7	532 12 41-81	Spring, Seat Cprsn
8	532 17 18-77	Bolt 5/16-18 unc x 3/4 w/Sems
10	532 19 69-77	Pan, Seat
21	532 17 18-52	Bolt, Shoulder 5/16-18

KEY NO.	PART NO.	DESCRIPTION
37	873 80 05-00	Nut, Lock 5/16-18 unc
40	532 19 76-61	Handle Slide Seat
41	532 19 82-00	Spring Latch Seat
43	874 76 06-12	Bolt Hex 3/8-16 x 3/4
44	819 13 38-12	Washer 13/32 x 2-3/8 x 12 Ga.

**NOTE:** All component dimensions given in U.S. inches  
1 inch = 25.4 mm



**TRACTOR - - MODEL NO. M13597H (96041000903), PRODUCT NO. 960 41 00-09  
MOWER LIFT 45**

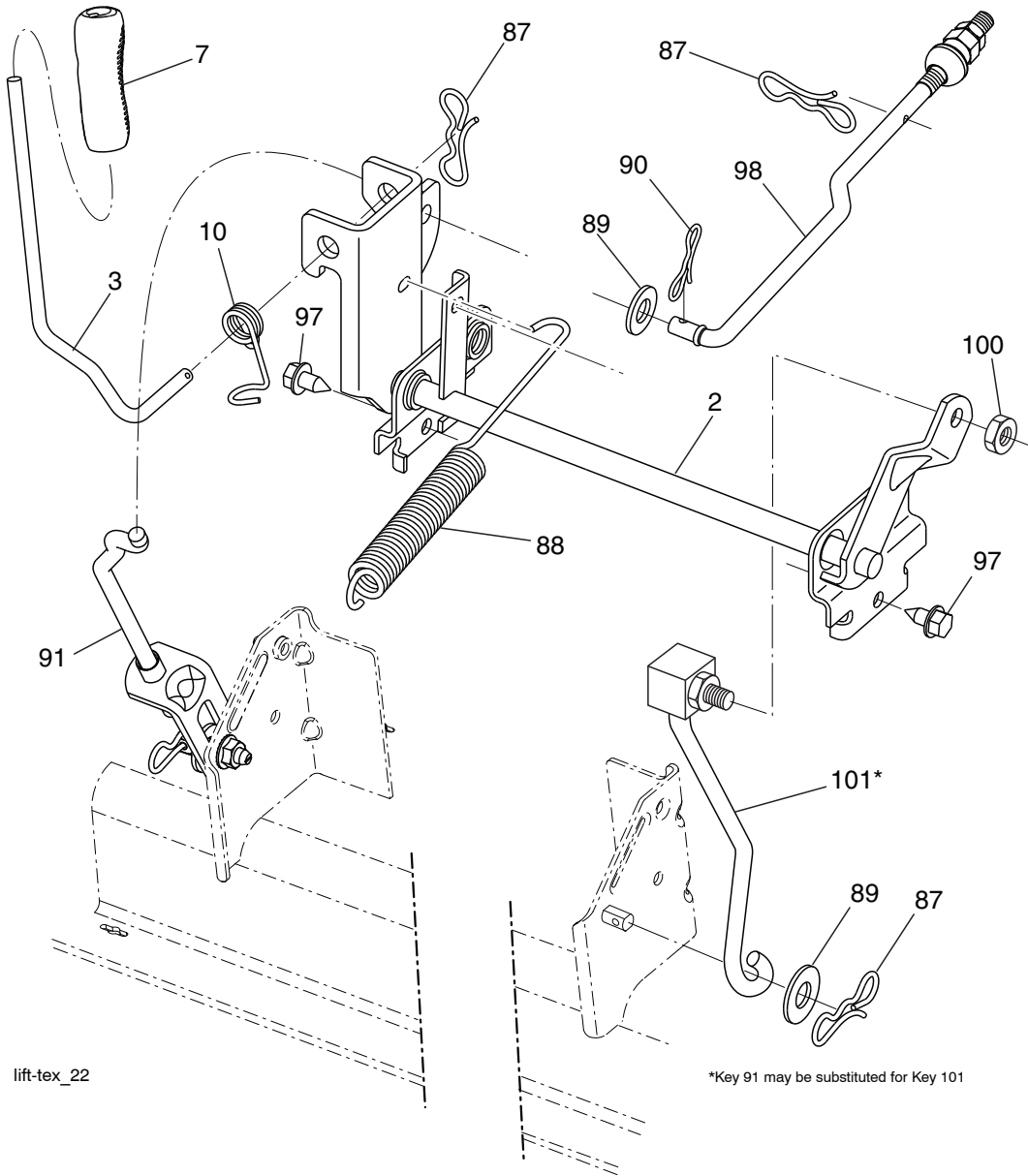

KEY NO.	PART NO.	DESCRIPTION
2	532 42 20-27	Shaft Asm., Lift
3	532 19 52-31	Lever Asm., Lift RH
7	532 41 17-42	Grip, Lever
10	532 19 63-14	Spring Torsion
87	532 19 42-09	Pin Cotter 7/16 Bow Tie Lock
88	532 41 07-10	Spring Lift Assist
89	819 17 19-12	Washer Clear Zinc
90	532 19 42-08	Pin Cotter 5/16 Bow Tie Lock
91	532 19 51-81	Link Lift Susp Mower Rear

KEY NO.	PART NO.	DESCRIPTION
97	817 00 06-12	Screw 3/8-16 x .75
98	532 19 52-70	Link Lift Susp. Front Mower
100	873 93 06-00	Nut Centerlock 3/8-16 unc
101	532 40 70-03	Link Asm Lift

**NOTE:** All component dimensions given in U.S. inches  
1 inch = 25.4 mm

