

# **ILLUSTRATED PARTS LIST**

**MODEL NO. 96041006501**

**CUSTOMER CATALOG NO. M200117H**

**PRODUCT NO. 960 41 00-65**

**TRACTOR - - MODEL NO. M200117H (96041006501), PRODUCT NO. 960 41 00-65  
DECALS 27**

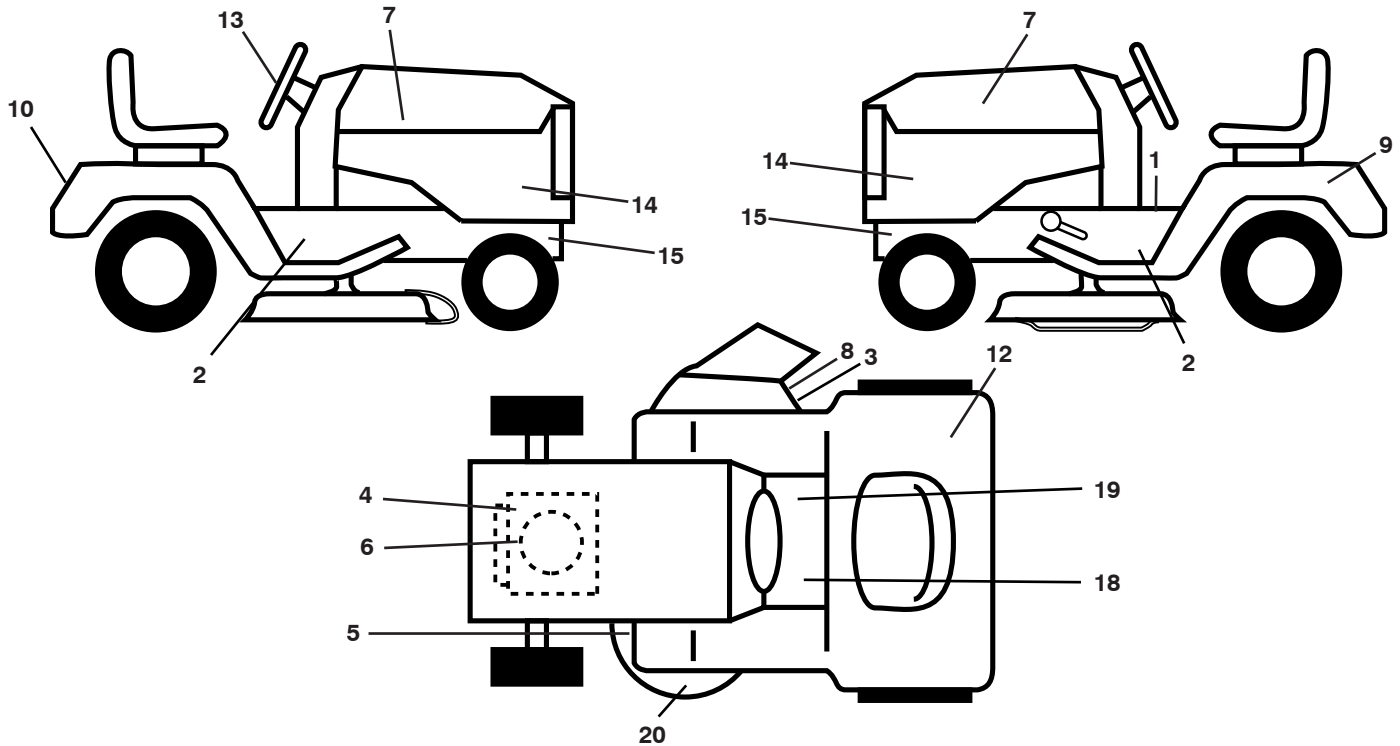

KEY NO.	PART NO.	DESCRIPTION
1	532 40 03-89	Decal, Warning Sym.
2	532 40 11-46	Decal, Warning Service/Fire
3	532 19 63-57	Decal, Warning
4	532 19 68-41	Decal, Warning Engine
5	532 16 03-96	Decal, V-Belt Sch.
6	532 40 88-38	Decal, Eng. HP
7	532 43 12-35	Decal, Hood LH/RH
8	532 18 21-66	Decal, Cutfinger
9	532 14 50-05	Decal, Battery Dnge/Poi
10	532 41 64-72	Decal, Fender
12	532 18 04-32	Decal, Fender DB/CE
13	532 40 82-02	Decal, Steering Whl

KEY NO.	PART NO.	DESCRIPTION
14	532 41 64-71	Decal, Panel Side
15	532 15 97-36	Decal, Hot Muffler
18	532 15 97-37	Decal, Clutch/Brake
19	532 14 08-37	Decal, Saddle Brake Parking
20	532 13 49-99	Decal, Enviro
--	532 16 69-60	Decal, Bypass
--	532 16 25-98	Decal, Load Limit
--	532 40 95-05	Pad, Footrest, LH
--	532 41 12-73	Pad, Footrest, RH
--	532 41 65-64	Manual, Oper Euro

**WHEELS AND TIRES**

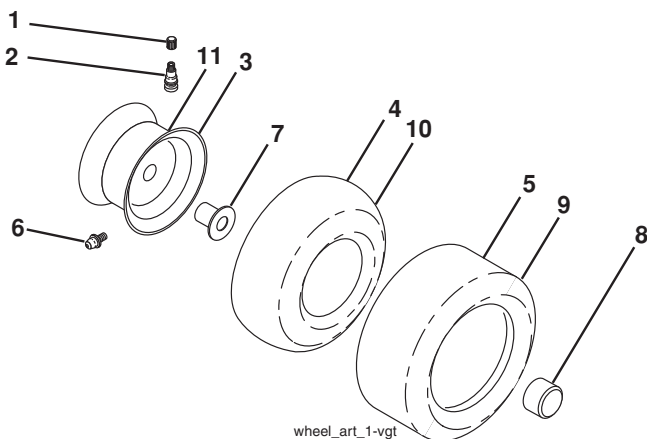

KEY NO.	PART NO.	DESCRIPTION
1	532 05 91-92	Cap, Valve, Tire
2	532 06 51-39	Stem, Valve
3	532 12 51-21	Rim Assembly, Front
4	532 05 99-04	Tube, Front (Service Item Only)
5	532 10 62-22	Tire, Front
6	532 12 49-57	Fitting, Grease (Front Wheel Only)
7	532 12 49-59	Bearing, Flange (Front Wheel Only)
8	532 17 50-39	Cap, Axle (Front Wheel Only)
9	532 13 84-68	Tire, Rear
10	532 12 49-26	Tube, Rear (Service Item Only)
11	532 12 51-22	Rim Assembly, Rear
--	532 14 43-34	Sealant, Tire (10 oz. Tube)

**NOTE:** All component dimensions given in U.S. inches  
1 inch = 25.4 mm

# TRACTOR - - MODEL NO. M200117H (96041006501), PRODUCT NO. 960 41 00-65 SCHEMATIC **38**

SCH13

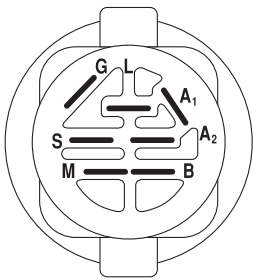
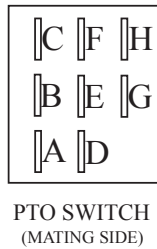
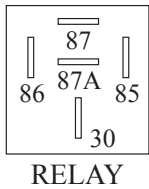
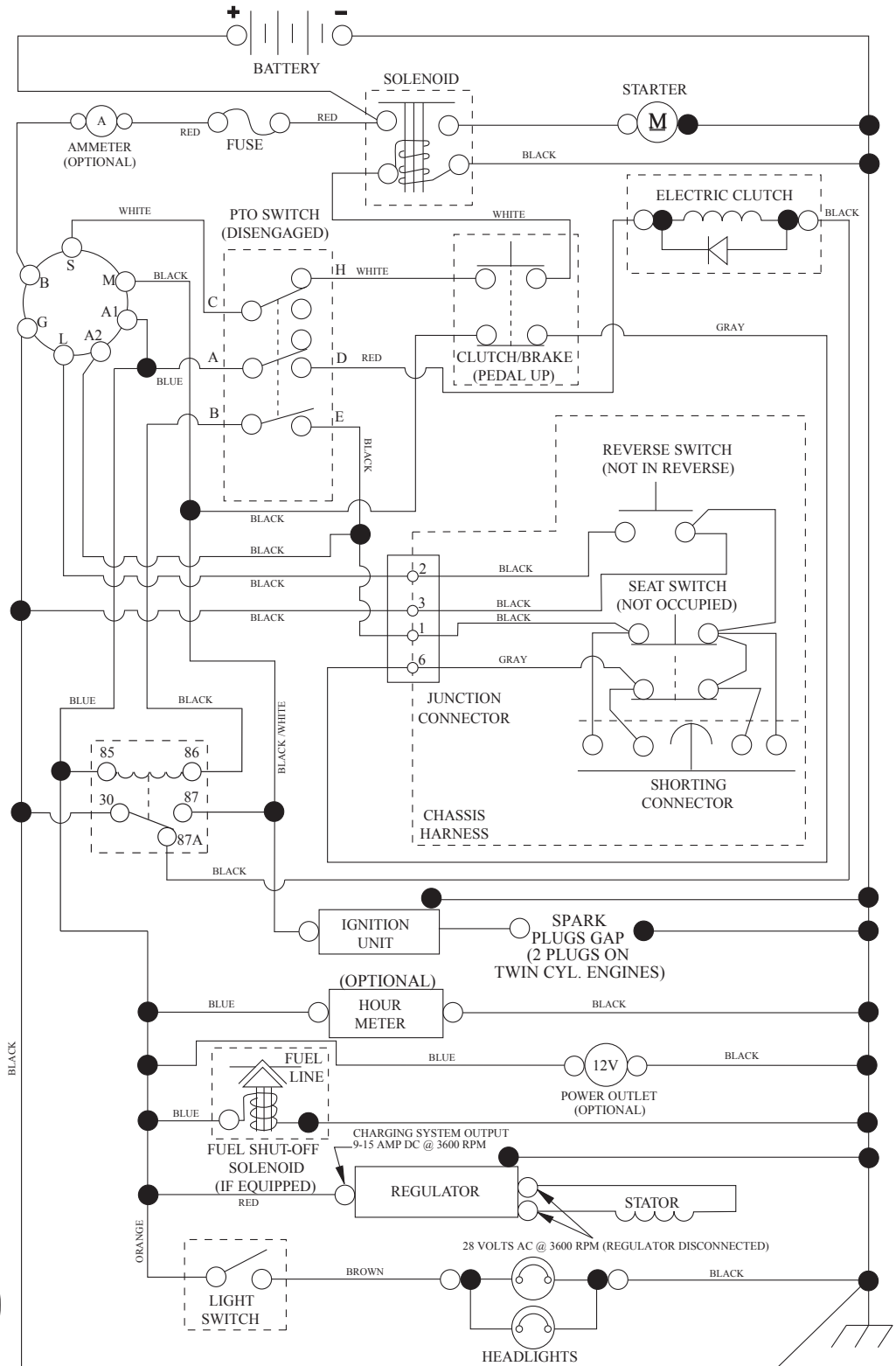

POSITION	CIRCUIT	"MAKE"
OFF	M+G+A1	
RUN/OVERRIDE	B+A1	
RUN	B+A1	L+A2
START	B + S + A1	

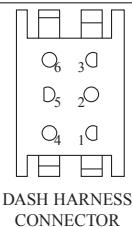
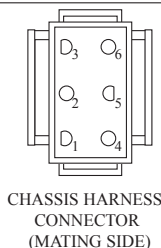

WIRING INSULATED CLIPS  
NOTE: IF WIRING INSULATED  
CLIPS WERE REMOVED FOR  
SERVICING OF UNIT, THEY  
SHOULD BE RE-INSTALLED TO  
PROPERLY SECURE YOUR  
WIRING.

●  
NON-REMOVABLE  
CONNECTIONS

○  
REMOVABLE  
CONNECTIONS

**TRACTOR - - MODEL NO. M200117H (96041006501), PRODUCT NO. 960 41 00-65  
ELECTRICAL 32**

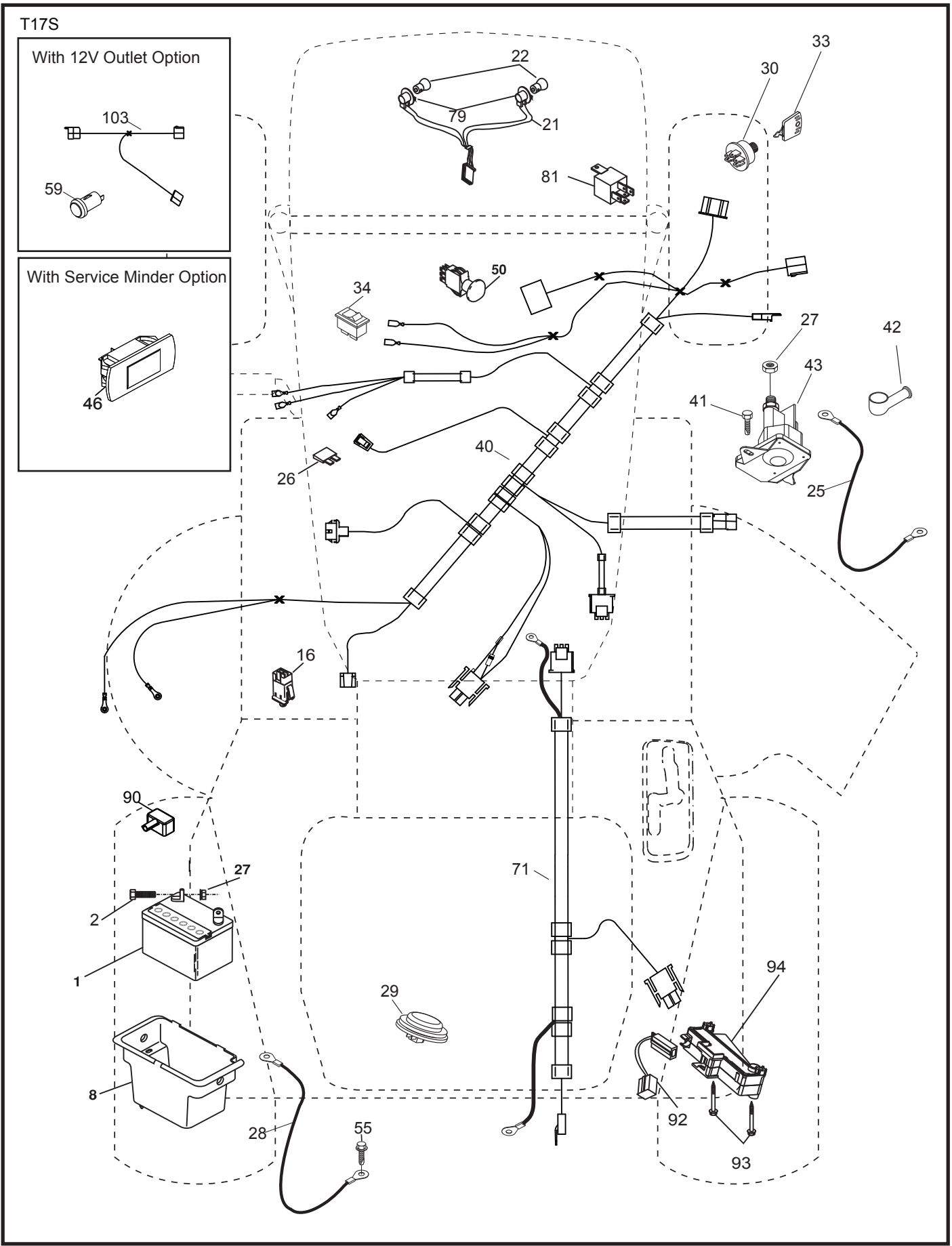

**TRACTOR - - MODEL NO. M200117H (96041006501), PRODUCT NO. 960 41 00-65  
ELECTRICAL 32**

<b>KEY NO.</b>	<b>PART NO.</b>	<b>DESCRIPTION</b>
1	532 16 34-65	Battery
2	874 76 04-12	Bolt Hex Hd 1/4-20 unc x 3/4
8	532 19 32-28	Battery Box
16	532 17 61-38	Switch Interlock
21	532 17 56-88	Harness Socket Light
22	532 00 41-52	Bulb, Light # 1156
25	532 41 28-95	Cable Starter
26	532 17 51-58	Fuse
27	873 51 04-00	Nut Keps Hex 1/4-20 unc
28	532 19 88-85	Cable Ground
29	532 40 15-45	Switch Seat
30	532 19 33-50	Switch Ign
33	532 41 19-35	Key/Chain
34	532 11 07-12	Switch Light/Reset
40	532 40 96-14	Harness Ign. Dash
41	817 72 04-08	Screw Thd Cut 1/4-20 x 1/2
42	532 13 15-63	Cover Terminal Red
43	532 19 25-07	Solenoid
50	532 17 46-53	Switch PTO
55	817 06 05-12	Screw Thdrol 5/16-18 x 3/4
71	532 40 04-49	Harness Chassis
79	532 17 52-42	Socket Asm. Bulb
81	532 40 96-15	Relay Harness Sealed
90	532 40 07-25	Cover Terminal Battery
92	532 19 66-15	Harness Pigtail Console ROS
93	532 19 25-40	Screw Plastite 10-14 x 2.0
94	532 19 18-34	Module Reverse ROS

**NOTE:** All component dimensions given in U.S. inches  
1 inch = 25.4 mm

**TRACTOR - - MODEL NO. M200117H (96041006501), PRODUCT NO. 960 41 00-65  
CHASSIS AND ENCLOSURES 39**

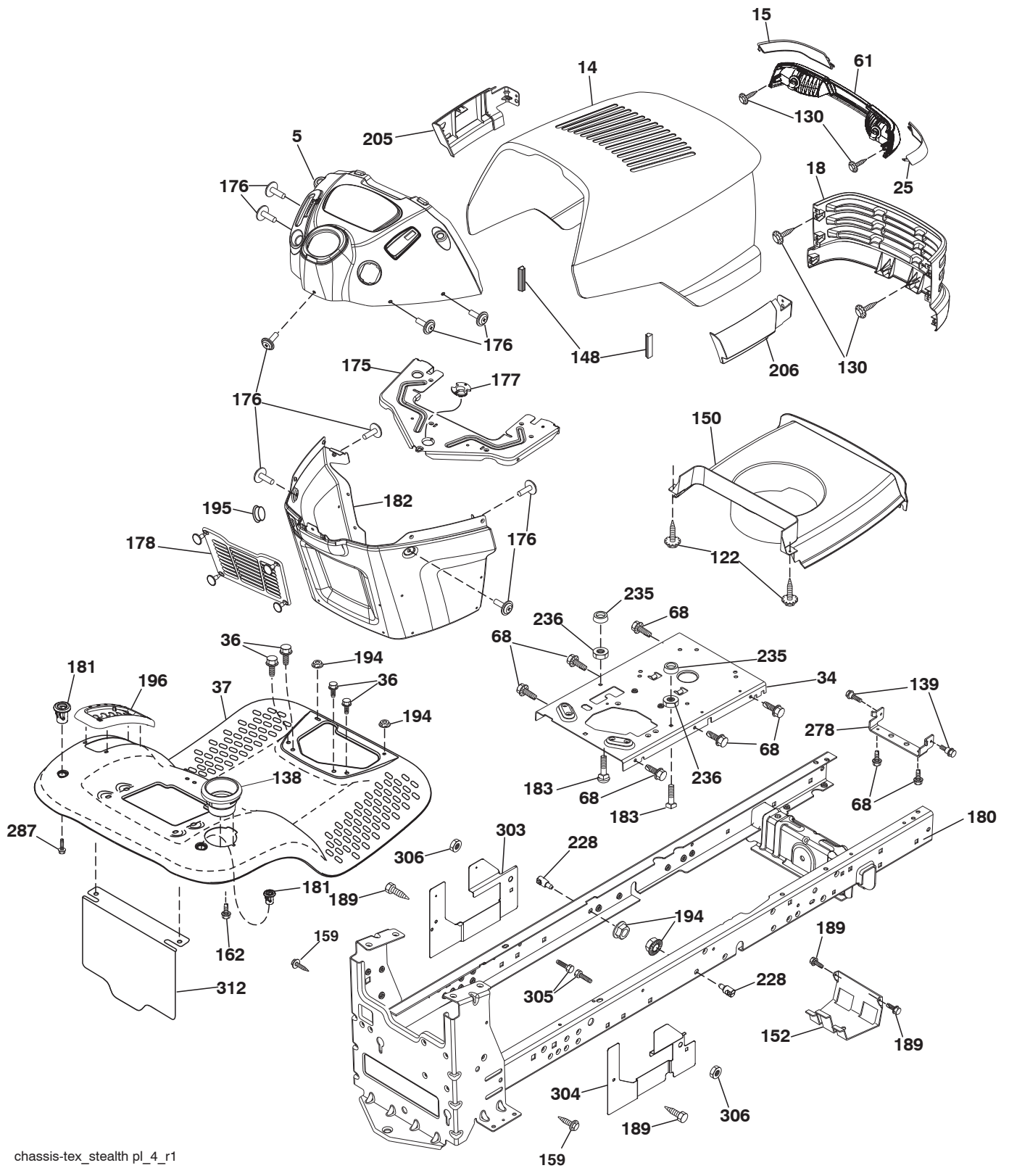

chassis-tex\_stealth pl\_4\_r1

**TRACTOR - - MODEL NO. M200117H (96041006501), PRODUCT NO. 960 41 00-65  
CHASSIS AND ENCLOSURES 39**

KEY NO.	PART NO.	DESCRIPTION	KEY NO.	PART NO.	DESCRIPTION
5	532 41 14-10	Dash	181	532 40 47-96	Bushing Mtg. Fender Crgo
14	532 19 49-77	Hood	182	532 19 25-51	Dash Lower
15	532 16 18-41	Lens LH	183	874 52 05-20	Bolt 5/16-18 x 1-1/4
18	532 18 71-14	Grille	189	817 00 05-12	Screw 5/16-18 x 3/4
25	532 16 18-42	Lens RH	194	873 90 05-00	Nut Lock Hex Flange 5/16-18
34	532 19 61-25	Plate Engine	195	532 40 41-37	Plug Hole Dash Lower
36	817 06 05-12	Screw 5/16-18 x 3/4	196	532 41 45-81	Console Asm. Deck Lift
37	532 42 09-86	Fender	205	532 18 71-12	Skirt Hood Side LH
61	532 17 97-63	Light Asm Dual	206	532 18 71-11	Skirt Hood Side RH
68	817 49 05-08	Screw Thdrol 5/16-1/8 x 1/2	228	532 19 51-61	Stud Fastner
122	532 19 25-12	Screw 10-32 x 5/8	235	532 40 61-29	Spacer Fender
130	532 41 63-58	Screw #10 x 0.750	236	873 93 05-00	Nut Lock 5/16-18 unc
138	532 40 97-30	Cupholder	278	532 19 63-94	Bracket Hood
139	532 17 18-73	Bolt Shoulder 5/16-18	287	817 60 04-06	Screw 1/4-20 x 3/8
148	532 16 46-55	Bumper Extrusion	303	532 42 09-59	Shield Chassis LH
150	532 19 03-08	Air Duct	304	532 42 15-09	Shield Chassis RH
152	532 19 95-35	Shield Browning	305	872 11 06-06	Bolt 3/8-16 x 3/4
159	817 00 06-12	Screw 3/8-16 x 3/4	306	973 90 06-00	Nut Lock 3/8-16
162	532 14 24-32	Screw Hex WSH Hi Lo 1/4 x 1/2 unc	312	532 42 59-26	Shield Drawbar
175	532 19 32-36	Crossmember	--	532 41 17-08	Plug Dash
176	532 40 07-76	Screw 10-24 x 5/8	--	532 41 14-11	Plug Cruise Control
177	532 19 52-27	Bushing Steering			
178	532 19 56-51	Cargo Net Asm.			
180	532 19 54-57	Chassis			

**NOTE:** All component dimensions given in U.S. inches  
1 inch = 25.4 mm

**TRACTOR -- MODEL NO. M200117H (96041006501), PRODUCT NO. 960 41 00-65**  
**DRIVE 40**

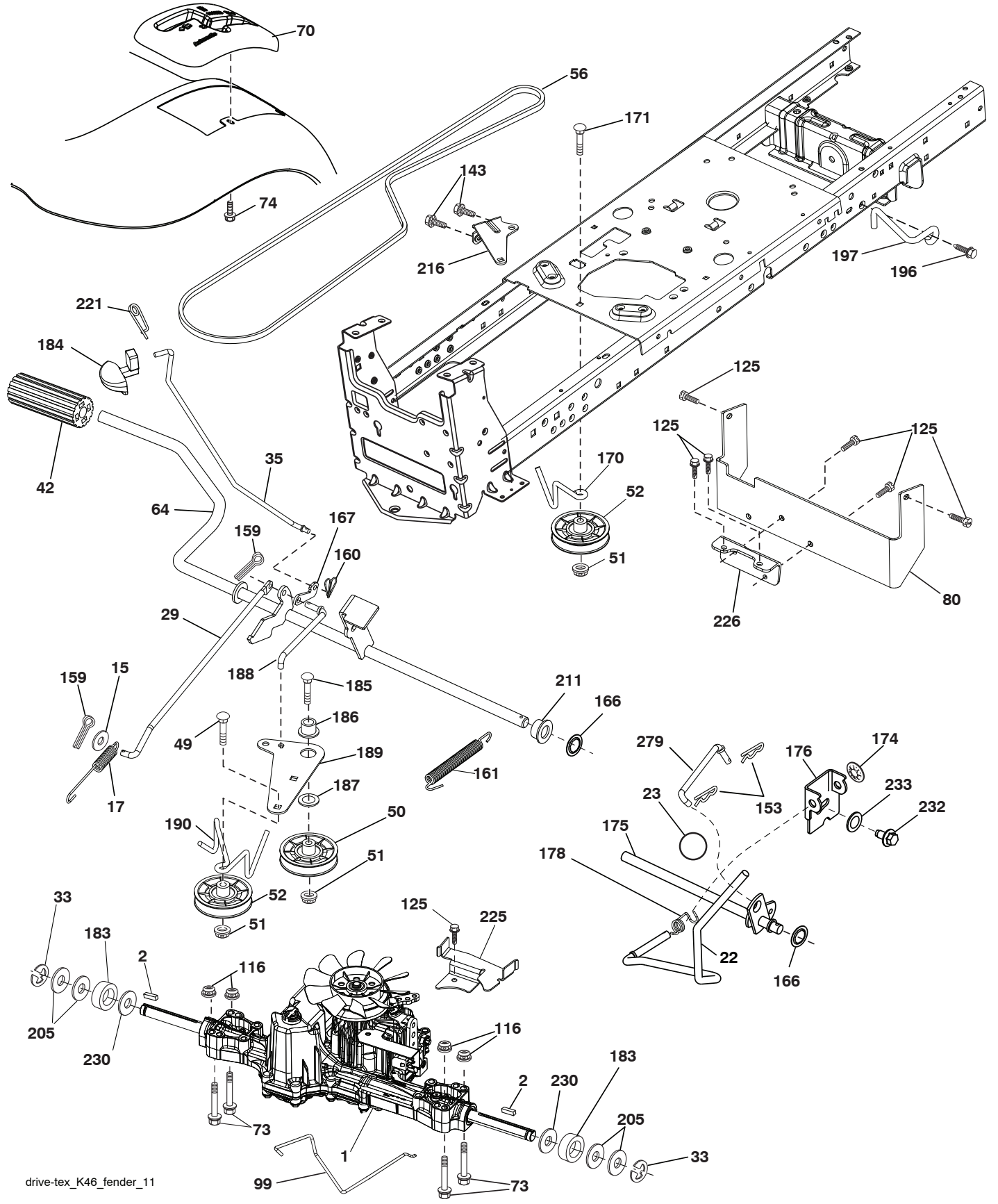

drive-tex\_K46\_fender\_11



**TRACTOR - - MODEL NO. M200117H (96041006501), PRODUCT NO. 960 41 00-65  
DRIVE **40****

KEY NO.	PART NO.	DESCRIPTION
1	-----	Transaxle, TUFFTORQ K46BA
2	532 12 35-83	Key
15	819 13 13-16	Washer 13/32 x 13/16 x 16 Ga.
17	532 41 36-78	Spring, Brake
22	532 19 76-60	Rod Shift
23	532 41 14-00	Knob
29	532 40 38-06	Rod, Brake
33	812 00 00-01	Ring E
35	532 19 72-75	Rod, Brake, Park
42	532 12 48-72	Cover, Foot Pedal
49	872 11 06-14	Bolt
50	532 19 43-27	Pulley Idler Flat
51	873 90 06-00	Lock Nut 3/8-16
52	532 19 43-26	Idler V-Groove 910" Offset
56	532 13 09-69	V-Belt, Drive
64	532 19 62-00	Shaft Asm. Pedal Brake Control
70	532 41 13-29	Console
73	874 49 05-44	Bolt Hex Flghd 5/16-18 Gr. 5
74	532 14 24-32	Screw 1/4 x 1/2
80	532 41 00-24	Strap Torque
99	532 41 57-42	Rod Bypass
116	873 90 05-00	Nut Lock Hex Flange 5/16-18
125	817 00 05-12	Screw 5/16-18 x 3/4
143	817 49 05-08	Screw Thdrol 5/16-18 x 1/2
153	532 12 47-88	Retainer Spring
159	876 02 04-12	Pin Cotter 1/8 x 3/4
160	532 16 94-84	Retainer Clip
161	532 10 57-09	Spring, Return, Clutch
166	532 19 72-90	Nut Push
167	532 40 52-57	Latch Brake Parking
170	532 19 43-22	Keeper Belt Centerspan

KEY NO.	PART NO.	DESCRIPTION
171	872 11 06-16	Bolt RDHD SQNK 3/8-16 unc x 2
174	532 19 72-89	Nut Push
175	532 40 62-08	Shaft Asm Shift
176	532 19 62-14	Arm Clevis Rod Shift
178	532 19 74-56	Spring Shift
183	532 13 70-57	Spacer Split
184	532 41 17-16	Handle Parking Brake
185	872 11 06-22	Bolt Rdhd 3/8-16 unc x 2-3/4 Gr. 5
186	532 19 43-21	Spacer Retainer
187	819 13 32-10	Washer
188	532 19 43-23	Link Clutch Ground Drive
189	532 19 43-17	Bellcrank Ground Drive
190	532 19 43-18	Keeper Bellcrank Ground Drive
196	817 00 06-16	Screw 3/8-16 x 1
197	532 19 58-04	Bracket Clutch Anti-Rotation
205	532 12 17-48	Washer
211	532 19 62-12	Bushing Brake Shaft
216	532 19 61-31	Bracket Pulley Idler
221	532 40 31-87	Retainer Spring Clip Handle
225	532 40 33-19	Keeper Belt Trans.
226	532 40 15-64	Bracket Mount Torque
230	532 18 89-67	Washer Hardened
233	532 40 52-96	Washer Serrated
276	874 78 07-16	Bolt 7/16-14 x 1 Gr. 5
279	532 40 62-07	Link Shift

NOTE: All component dimensions given in U.S. inches  
1 inch = 25.4 mm

**TRACTOR - - MODEL NO. M200117H (96041006501), PRODUCT NO. 960 41 00-65**  
**STEERING ASSEMBLY [41]**

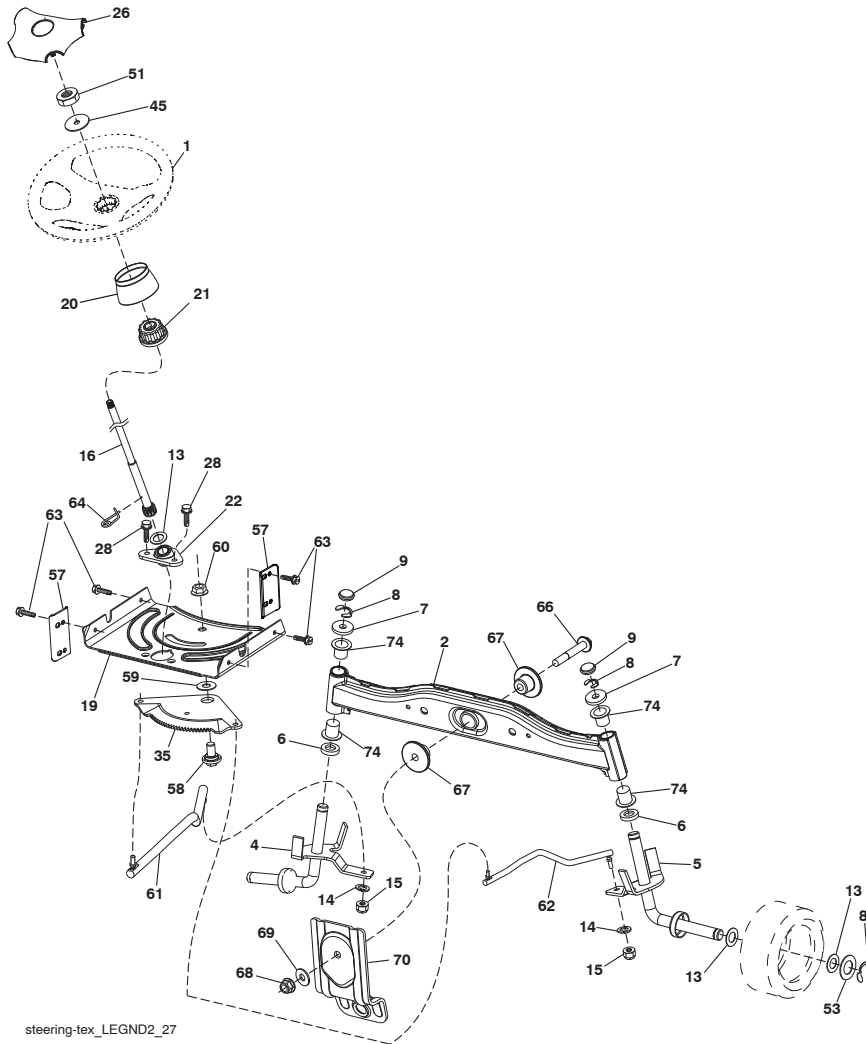

steering-tex\_LEGND2\_27

KEY NO.	PART NO.	DESCRIPTION	KEY NO.	PART NO.	DESCRIPTION
1	532 19 45-95	Wheel, Steering	51	873 94 08-00	Nut Hex Jam Toplock 1/2-20 unf
2	532 41 81-68	Axle Asm., Front	53	532 18 89-67	Washer Hardened .793 x 1.637 x .060
4	532 40 30-87	Spindle Asm., LH	57	532 40 74-65	Bracket Upstop
5	532 40 30-88	Spindle Asm., RH	58	532 19 47-47	Bolt Shoulder Sector Pivot CFM
6	532 12 49-31	Bearing, Race Thrust Harden	59	532 19 47-48	Washer Thrust Sector Steering
7	532 12 17-48	Washer 25/32 x 1-5/8 x 16 Ga.	60	873 97 10-00	Nut Flange Lock 5/8-11
8	812 00 00-29	Ring, Clip #T5304-75	61	532 19 47-40	Draglink LH
9	532 12 12-32	Cap, Spindle	62	532 19 47-41	Draglink, RH
13	532 12 17-49	Washer 25/32 x 1-1/4 x 16 Ga.	63	817 00 05-12	Screw 5/16-18 x 3/4
14	810 04 06-00	Washer, Lock Hvy Hlcl Spr 3/8	64	532 19 98-49	Retainer Clip Spring Steering
15	873 54 06-00	Nut, Crown Lock 3/8-24 unf	66	871 02 07-48	Bolt Hex Fghd 7/16-14 x 3 Serr
16	532 19 47-46	Shaft Steering	67	532 19 47-37	Bushing PM Front Axle
19	532 19 47-29	Plate Steering	68	873 90 07-00	Nut Lock Flange 7/16-14 Gr. 5
20	532 41 14-25	Boot Steering	69	532 19 91-62	Washer 1.5 x .505 x .118
21	532 18 67-37	Adapter, Wheel Steering	70	532 19 61-97	Bracket Deck Susp. Front
22	532 19 48-45	Bushing, Strg. Blk	74	532 12 49-37	Bearing
26	532 19 46-03	Insert, Wheel Steering			
28	817 00 06-12	Screw 3/8-16 x 3/4			
35	532 19 47-32	Gear, Sector Plate			
45	819 11 38-12	Washer 11/32 x 2-3/8 x 12 Ga.			

**NOTE:** All component dimensions given in U.S. inches  
 1 inch = 25.4 mm

**TRACTOR - - MODEL NO. M200117H (96041006501), PRODUCT NO. 960 41 00-65  
SEAT ASSEMBLY 42**

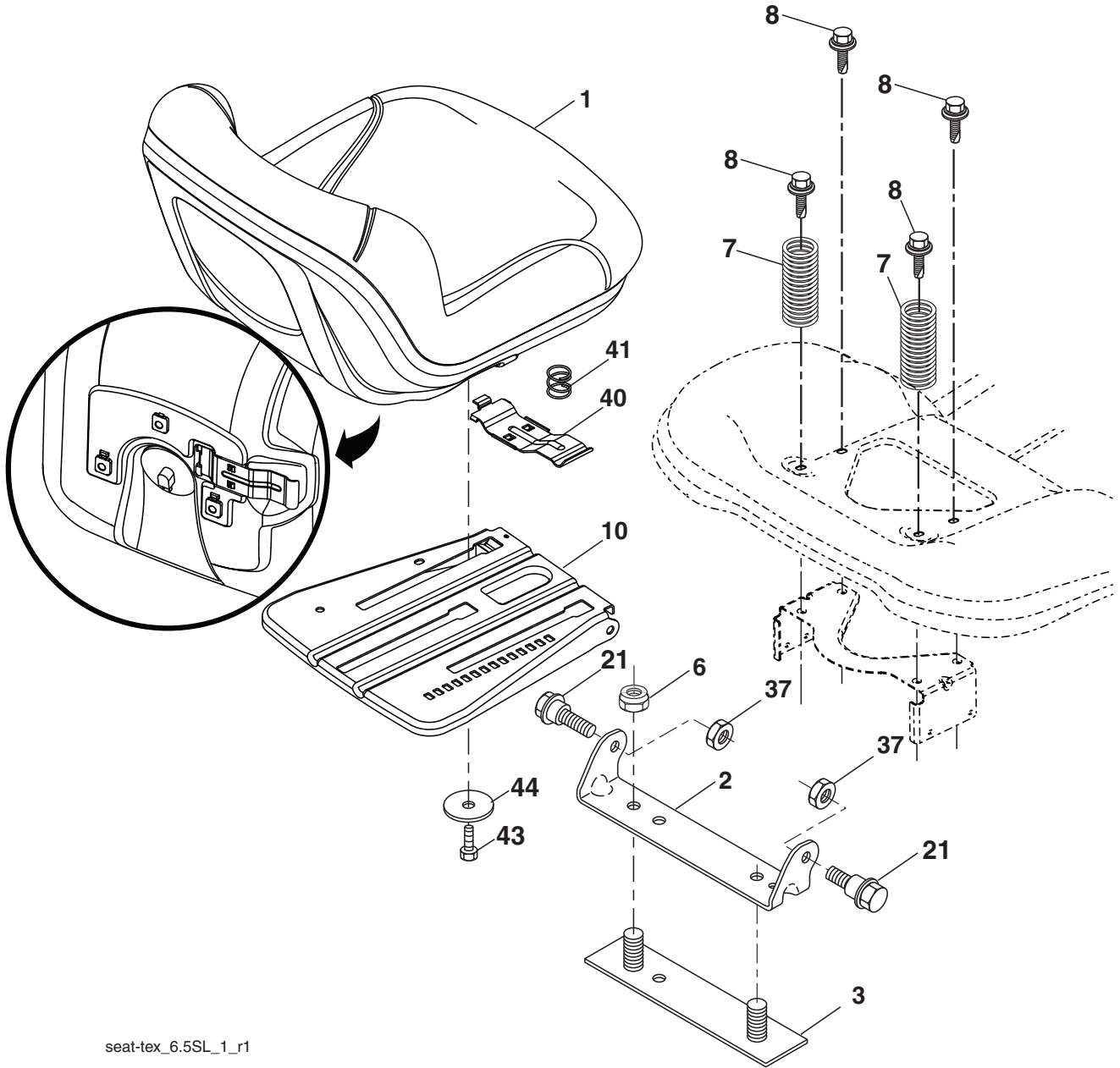

seat-tex\_6.5SL\_1\_r1

KEY NO.	PART NO.	DESCRIPTION
1	532 19 75-11	Seat
2	532 18 01-66	Bracket Pivot Fender
3	532 14 06-75	Strap, Asm Fender
6	873 80 06-00	Nut, Lock w/Ins. 3/8-16 unc
7	532 12 41-81	Spring, Seat Cprsn
8	532 17 18-77	Bolt 5/16-18 unc x 3/4 w/Sems
10	532 19 69-77	Pan, Seat
21	532 17 18-52	Bolt, Shoulder 5/16-18

KEY NO.	PART NO.	DESCRIPTION
37	873 80 05-00	Nut, Lock 5/16-18 unc
40	532 19 76-61	Handle Slide Seat
41	532 19 82-00	Spring Latch Seat
43	874 76 06-12	Bolt 3/8-16 x 3/4
44	819 13 38-12	Washer 13/32 x 2-3/8 x 12 Ga.

**NOTE:** All component dimensions given in U.S. inches  
1 inch = 25.4 mm

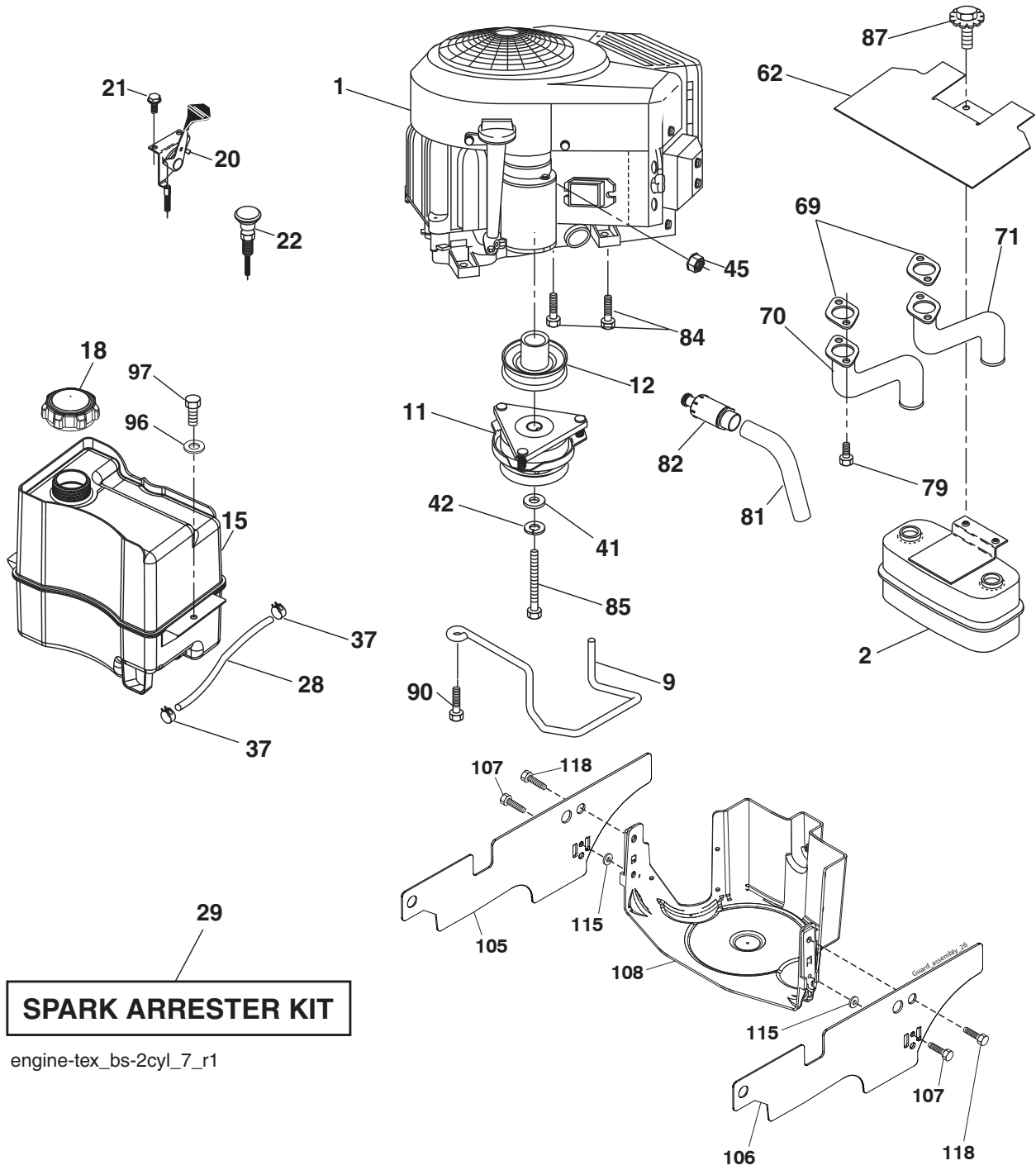

**SPARK ARRESTER KIT**

engine-tex\_bs-2cyl\_7\_r1

**TRACTOR - - MODEL NO. M200117H (96041006501), PRODUCT NO. 960 41 00-65  
ENGINE 24**

KEY NO.	PART NO.	DESCRIPTION
1	-----	Engine Briggs Model No. 406777
2	532 14 97-23	Muffler
9	532 19 43-20	Keeper Belt Engine
11	532 40 00-08	Clutch Electric
12	532 40 50-97	Pulley Engine
15	532 40 75-51	Tank Fuel
18	532 19 77-25	Cap Asm
20	532 41 67-96	Control Throttle
21	532 41 63-58	Screw #10 x 0.750 BOS Thread
22	532 42 64-96	Control Choke
28	532 13 70-40	Fuel Line
29	532 13 71-80	Spark Arrester Kit
37	532 12 34-87	Clamp Hose
41	532 12 61-97	Washer 1-1/2 OD x 15/32 ID x .250
42	810 04 07-00	Washer Lock 7/16
45	873 51 04-00	Nut Keps Hex 1/4-20 unc
62	532 14 66-29	Shield Heat
69	532 16 52-91	Gasket
70	532 16 05-89	Exhaust Tube RH

KEY NO.	PART NO.	DESCRIPTION
71	532 15 99-55	Exhaust Tube LH
79	532 18 39-06	Screw 5/16-18 x 1
81	532 14 84-56	Tube Drain Oil Easy
82	532 18 16-54	Plug Drain Oil
84	817 06 06-20	Screw 3/8-16 x 1-1/4
85	532 17 39-37	Bolt 7/16-20 x 4
87	532 19 82-39	Bolt 5/16-18 unc x 1
90	817 00 06-16	Screw 3/8-16 x 1
96	819 09 14-16	Washer 9/32 x 7/8 x 16 Ga.
97	817 67 04-12	Screw 1/4 - 20 x 3/4
105	532 41 56-06	Shield Side LH
106	532 41 56-11	Shield Side RH
107	532 13 77-29	Screw 1/4-20 x 5/8
108	532 42 68-03	Cover Asm
115	532 42 30-62	Palnut 1/4"
118	817 67 05-08	Screw Thdrol 5/16-18 x 1/2

**NOTE:** All component dimensions given in U.S. inches  
1 inch = 25.4 mm

**Engine Power Rating Information**

The gross power rating for individual gas engine models is labeled in accordance with SAE (Society of Automotive Engineers) code J1940 (Small Engine Power & Torque Rating Procedure), and rating performance has been obtained and corrected in accordance with SAE J1995 (Revision 2002-05). Torque values are derived at 3060 RPM; horsepower values are derived at 3600 RPM. Actual gross engine power will be lower and is affected by, among other things, ambient operating conditions and engine-to-engine variability. Given both the wide array of products on which engines are placed and the variety of environmental issues applicable to operating the equipment, the gas engine will not develop the rated gross power when used in a given piece of power equipment (actual "on-site" or net power). This difference is due to a variety of factors including, but not limited to, accessories (air cleaner, exhaust, charging, cooling, carburetor, fuel pump, etc.), application limitations, ambient operating conditions (temperature, humidity, altitude), and engine-to-engine variability. Due to manufacturing and capacity limitations, Briggs & Stratton may substitute an engine of higher rated power for this Series engine.

**TRACTOR - - MODEL NO. M200117H (96041006501), PRODUCT NO. 960 41 00-65  
MOWER DECK 44**

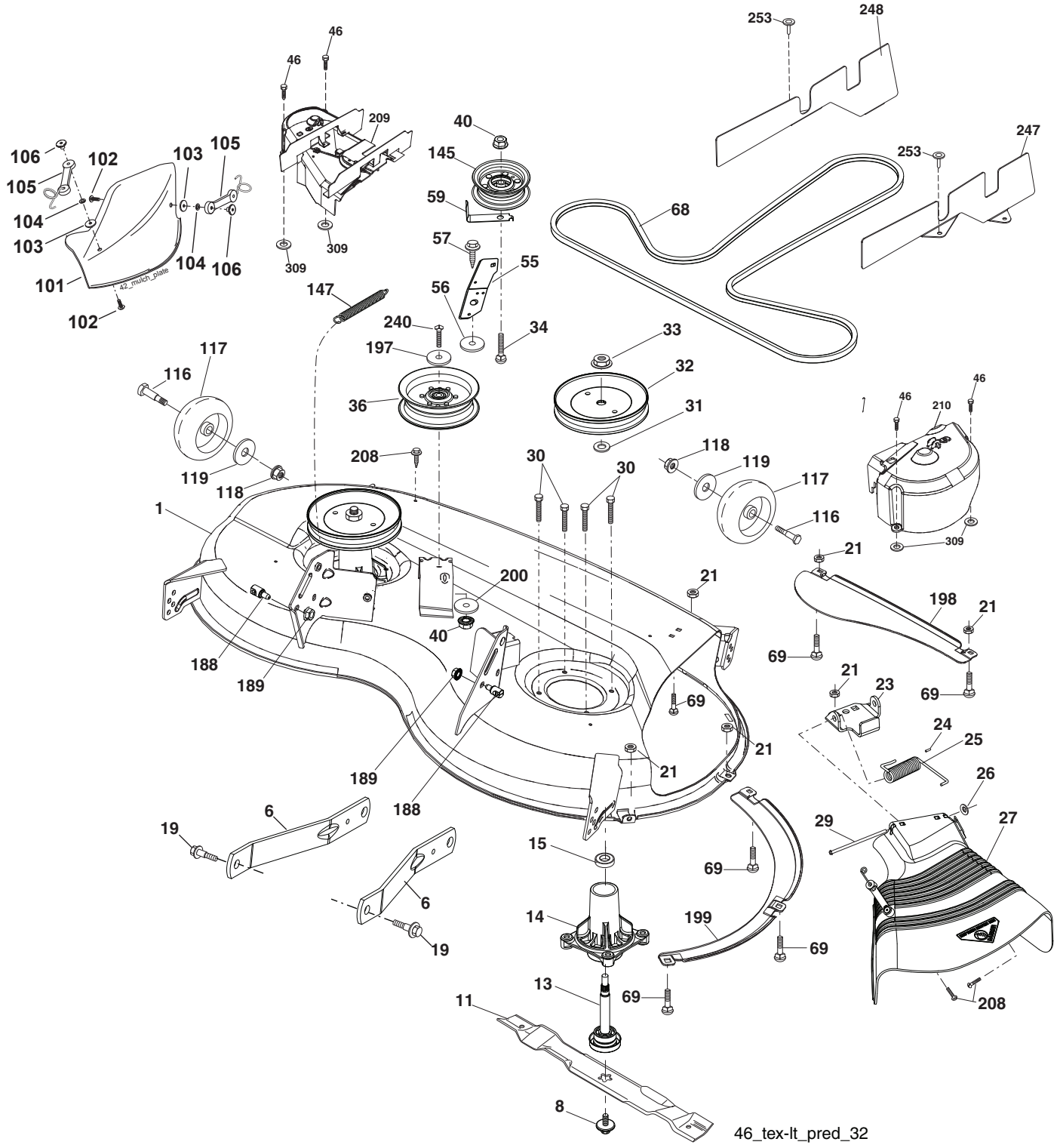

**TRACTOR - - MODEL NO. M200117H (96041006501), PRODUCT NO. 960 41 00-65  
MOWER DECK 44**

KEY NO.	PART NO.	DESCRIPTION	KEY NO.	PART NO.	DESCRIPTION
1	532 44 16-16	Mower Housing	104	810 07 10-00	Washer Lock #10
6	532 19 51-86	Arm Suspension	105	532 16 07-93	Latch Asm
8	532 19 30-03	Bolt/Washer Asm 7/16-20 unf	106	532 12 50-04	Nut Weld
11	532 40 31-07	Blade	116	532 19 34-06	Bolt, Shoulder
13	532 19 28-72	Shaft Assembly, Mandrel	117	532 17 48-73	Wheel, Gauge
14	532 18 72-81	Housing, Mandrel	118	873 90 06-00	Nut, Lock 3/8-16 unc
15	532 11 04-85	Bearing, Ball, Mandrel	119	819 13 20-12	Washer 13/32 x 1-1/4 x 12 Ga.
19	532 19 65-39	Bolt, Shoulder	145	532 19 73-79	Pulley Idler
21	873 68 05-00	Nut, Crownlock 5/16-18 unc	147	532 19 72-51	Spring Mower Drive Electric
23	532 19 25-57	Bracket, Deflector	188	532 19 51-61	Stud Fastener
24	532 10 53-04	Cap, Sleeve	189	873 90 05-00	Nut Lock Hex Flange
25	532 19 70-26	Spring, Torsion, Deflector	197	819 13 13-12	Washer 13/32 x 13/16 x 12 Ga.
26	532 11 04-52	Nut, Push	198	532 40 31-49	Baffle Center Front
27	532 41 53-69	Shield, Deflector	199	532 40 31-50	Baffle Front RH
29	532 13 14-91	Rod, Hinge	200	532 41 35-24	Washer 13/32 x 1 x 1/2 x 11 Ga.
30	532 17 39-84	Screw Thdrol Rolling Wsh Hd	208	817 67 06-08	Screw 3/8-16 x 1/2
31	532 18 76-90	Washer, Spacer	209	532 42 49-86	Cover Mandrel LH
32	532 19 74-73	Pulley, Mandrel	210	532 42 49-88	Cover Mandrel RH
33	532 40 02-34	Nut, Toplock, Flanged	240	874 52 06-36	Bolt Fin Hex 3/8-16 x 2-1/4 Gr. 5
34	872 11 06-12	Bolt Carr Sh. 3/8-16 x 1-1/2 Gr. 5	247	532 42 16-68	Shield Deck RH
36	532 19 31-97	Pulley, Idler, Primary	248	532 42 16-69	Shield Deck LH
40	873 90 06-00	Nut, Lock Flg. 3/8-16 unc	253	532 42 73-50	Tulflok Rivet
46	532 13 77-29	Screw 1/4-20 x 5/8	309	532 42 30-62	Palnut 1/4"
55	532 19 72-49	Arm, Idler	--	532 19 28-70	Mandrel Assembly (Includes housing, shaft and shaft hardware only-pulley not included)
56	532 19 90-92	Spacer, Retainer	--	<b>532 42 72-03</b>	Replacement Mower, Complete
57	817 00 06-16	Screw 3/8-16 x 1			
59	532 14 10-43	Guard, Tuv Idler			
68	532 40 51-43	V-Belt			
69	872 14 05-05	Bolt			
101	532 40 54-54	Cover Mulching			
102	871 08 10-10	Screw 10-24 x 5/8			
103	819 06 12-16	Washer #10			

**NOTE:** All component dimensions given in U.S. inches  
1 inch = 25.4 mm

**TRACTOR - - MODEL NO. M200117H (96041006501), PRODUCT NO. 960 41 00-65**  
**MOWER LIFT 45**

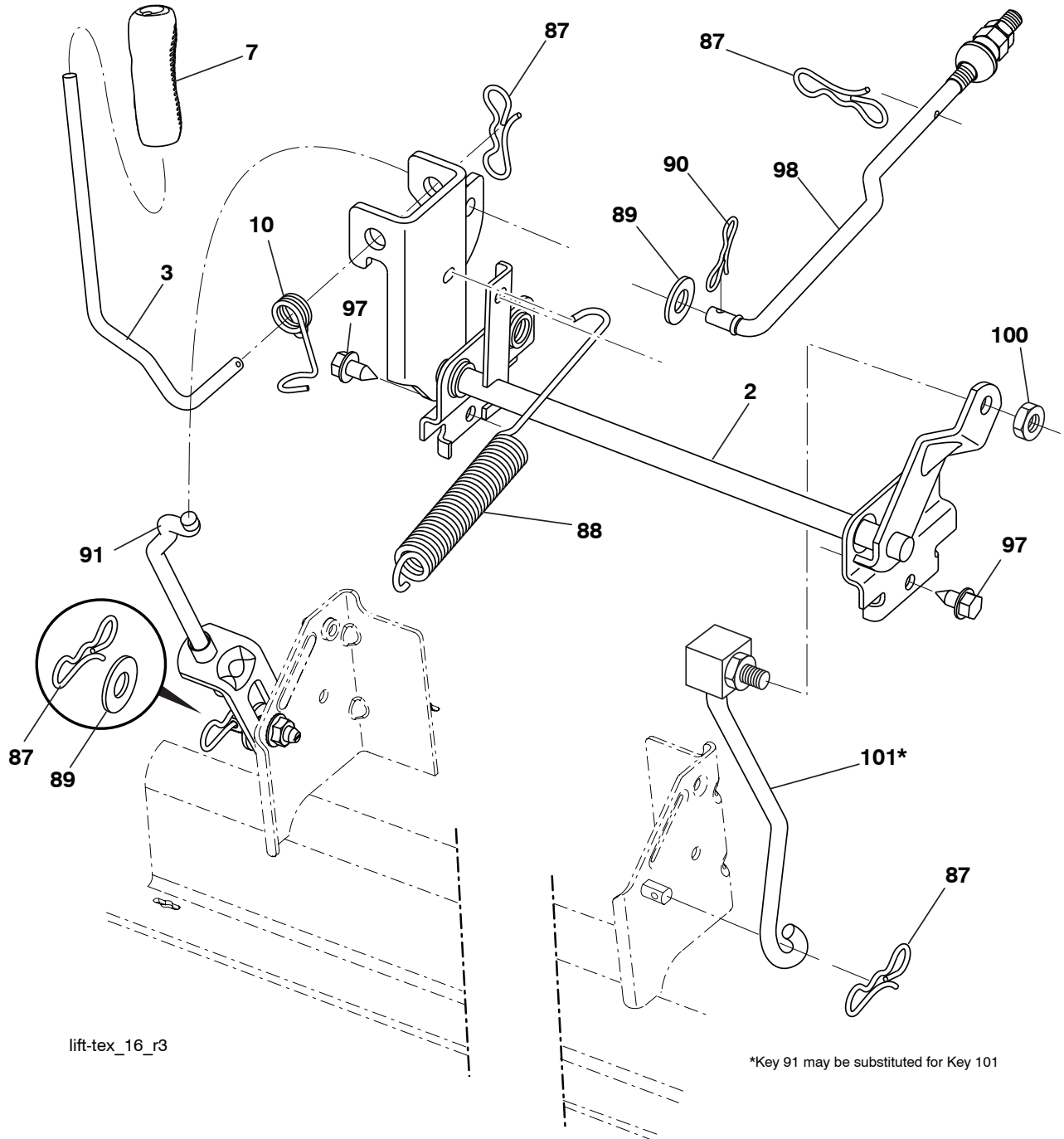

KEY NO.	PART NO.	DESCRIPTION
2	532 19 52-23	Shaft Asm., Lift
3	532 19 52-31	Lever Asm., Lift RH
7	532 41 17-42	Grip, Lever
10	532 19 63-14	Spring Torsion
87	532 19 42-09	Pin Cotter 7/16 Bow Tie Lock
88	532 41 07-10	Spring Lift Assist
89	819 19 19-12	Washer 17/32 x 1-3/16 x 12 Ga.
90	532 19 42-08	Pin Cotter 5/16 Bow Tie Lock

KEY NO.	PART NO.	DESCRIPTION
91	532 19 51-81	Link Lift Susp Mower Rear
97	817 00 06-12	Screw 3/8-16 x .75
98	532 19 52-70	Link Lift Susp. Front Mower
100	873 93 06-00	Nut Centerlock 3/8-16
101	532 40 70-03	Link Asm. Lift FXD

**NOTE:** All component dimensions given in U.S. inches  
 1 inch = 25.4 mm



