

**REPAIR PARTS MANUAL**  
**MODEL NO. M155107H (96041001000)**  
**Lawn Tractor**

---



**McCULLOCH**

[www.mcculloch.biz](http://www.mcculloch.biz)

# TRACTOR - MODEL NO. M155107H (96041001000), PRODUCT NO. 960 41 00-10 DECALS

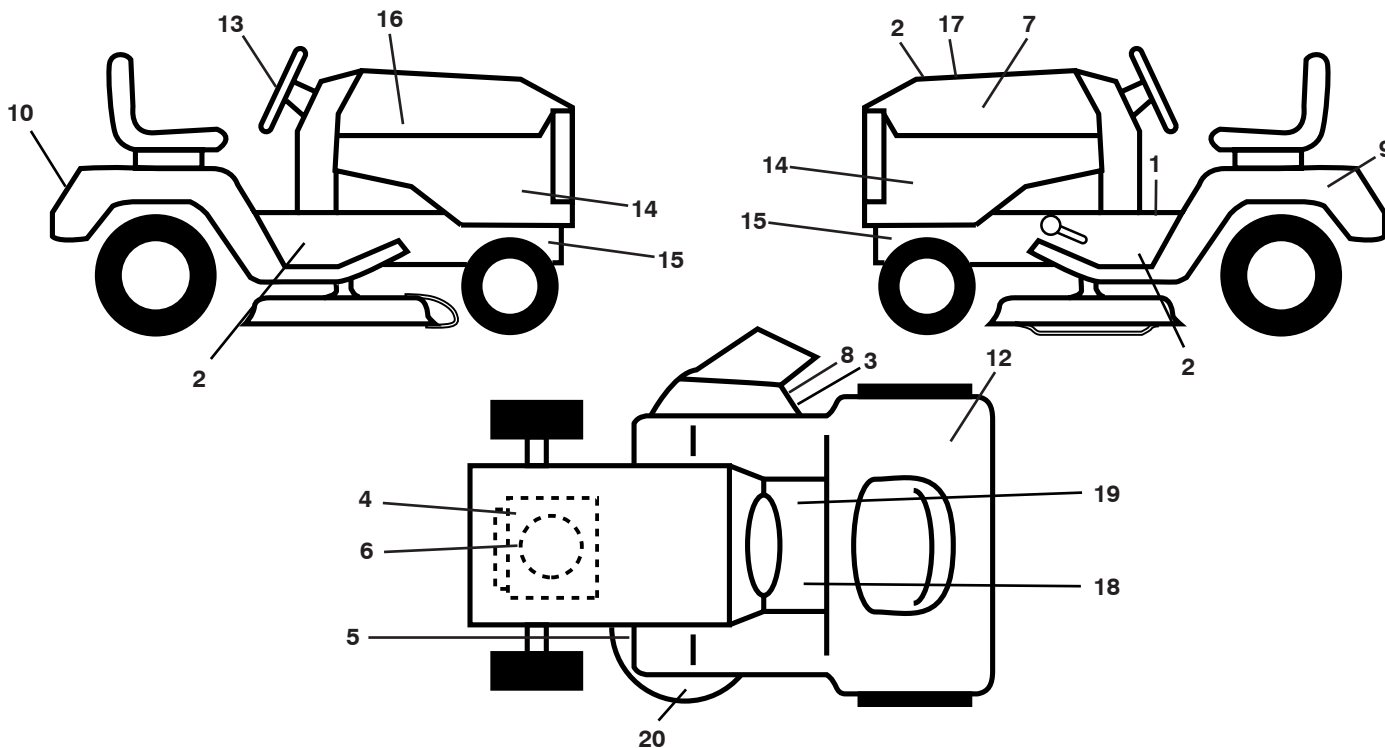

KEY NO.	PART NO.	DESCRIPTION
1	532 40 03-89	Decal, Warning Sym.
2	532 19 68-42	Decal, Warning
3	532 19 63-57	Decal, Warning
4	532 19 68-41	Decal, Warning Engine
5	532 16 03-96	Decal, V-Belt Sch.
6	532 40 88-17	Decal, Eng. HP
7	532 40 82-55	Decal, Hood LH
8	532 18 21-66	Decal, Cutfinger
9	532 14 50-05	Decal, Battery Dnge/Poi
10	532 40 90-01	Decal, Fender
12	532 18 04-32	Decal, Fender DB/CE
13	532 40 82-02	Decal, Steering Whl

KEY NO.	PART NO.	DESCRIPTION
14	532 40 90-00	Decal, Panel Side
15	532 15 97-36	Decal, Hot Muffler
16	532 40 82-54	Decal, Hood RH
18	532 15 97-37	Decal, Clutch/Brake
19	532 14 08-37	Decal, Saddle Brake Parking
20	532 13 49-99	Decal, Enviro
--	532 16 69-60	Decal, Bypass
--	532 16 25-98	Decal, Load Limit
--	532 40 95-04	Pad, Footrest, LH
--	532 41 12-73	Pad, Footrest, RH
--	532 40 94-88	Manual, Oper Euro
--	532 40 94-89	Manual, Oper Scan
--	532 40 94-91	Manual, Parts

## WHEELS AND TIRES

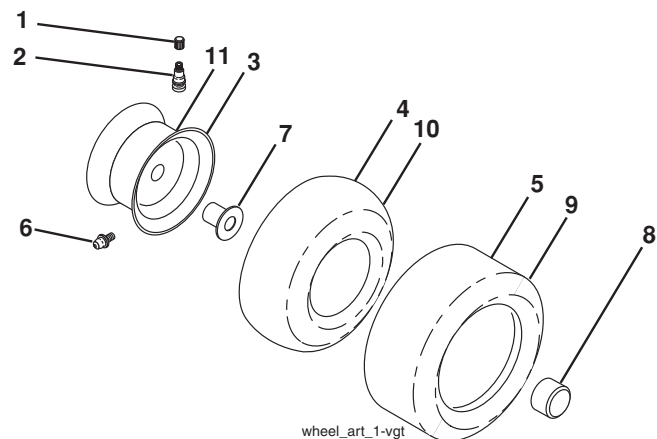

KEY NO.	PART NO.	DESCRIPTION
1	532 05 91-92	Cap, Valve, Tire
2	532 06 51-39	Stem, Valve
3	532 12 51-21	Rim Assembly, Front
4	532 05 99-04	Tube, Front (Service Item Only)
5	532 10 62-22	Tire, Front
6	532 12 49-57	Fitting, Grease (Front Wheel Only)
7	532 12 49-59	Bearing, Flange (Front Wheel Only)
8	532 17 50-39	Cap, Axle (Front Wheel Only)
9	532 13 84-68	Tire, Rear
10	532 12 49-26	Tube, Rear (Service Item Only)
11	532 12 51-22	Rim Assembly, Rear
--	532 14 43-34	Sealant, Tire (10 oz. Tube)

wheel\_art\_1-vgt

# TRACTOR - MODEL NO. M155107H (96041001000), PRODUCT NO. 960 41 00-10 SCHEMATIC

9-194276\_Regulated-Tex

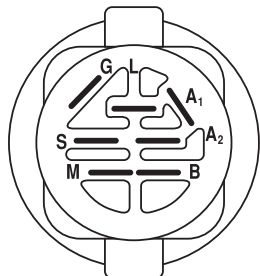
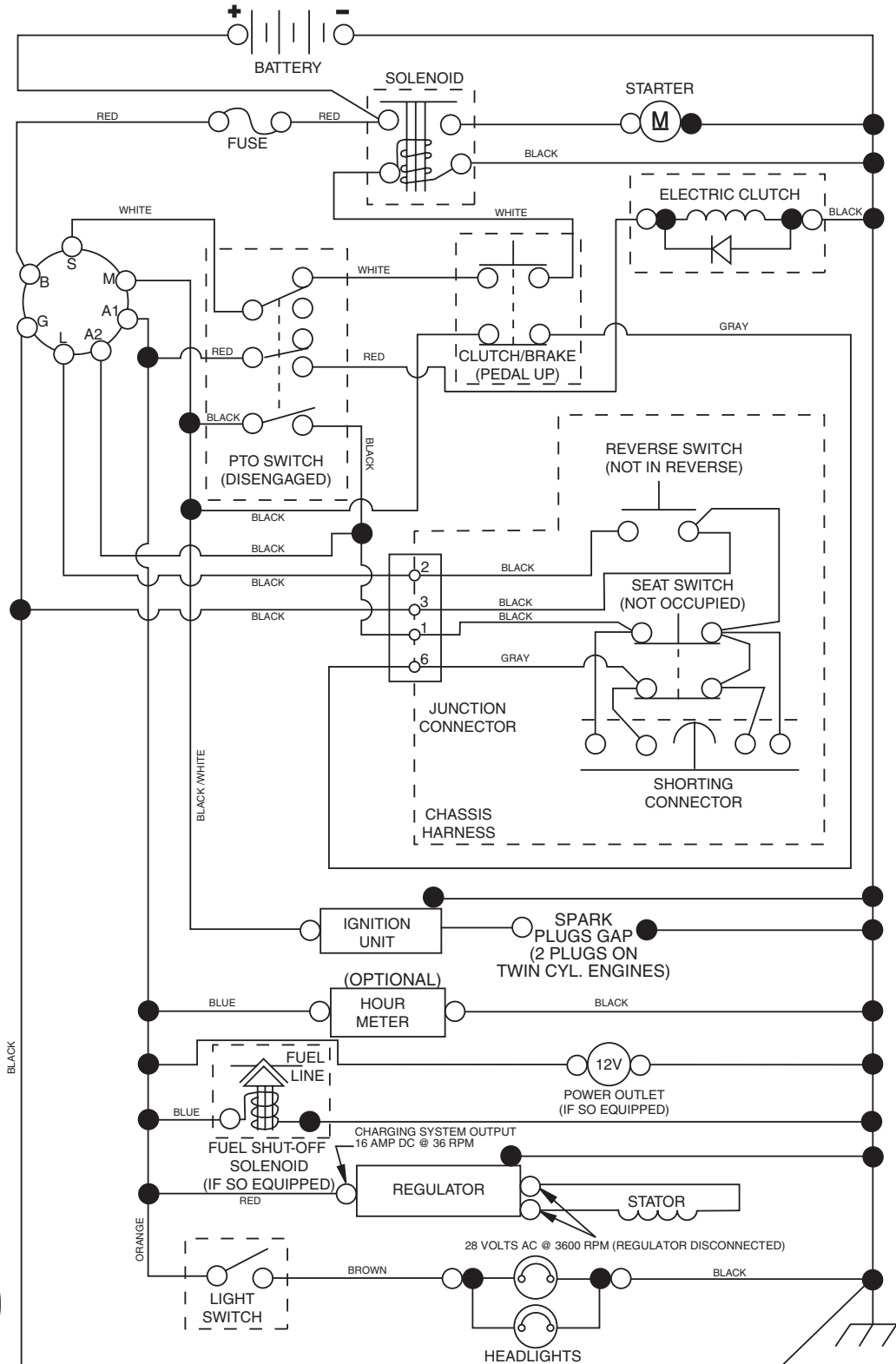

**IGNITION SWITCH**

POSITION	CIRCUIT "MAKE"
OFF	M+G+A1
RUN/OVERRIDE	B+A1
RUN	B+A1 L+A2
START	B + S + A1

02929

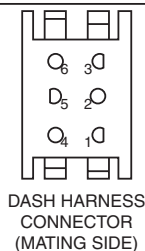
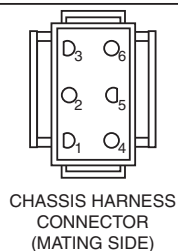

**WIRING INSULATED CLIPS**  
**NOTE:** IF WIRING INSULATED CLIPS WERE REMOVED FOR SERVICING OF UNIT, THEY SHOULD BE REPLACED TO PROPERLY SECURE YOUR WIRING.

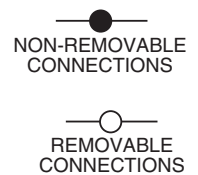

**TRACTOR - MODEL NO. M155107H (96041001000), PRODUCT NO. 960 41 00-10  
ELECTRICAL**

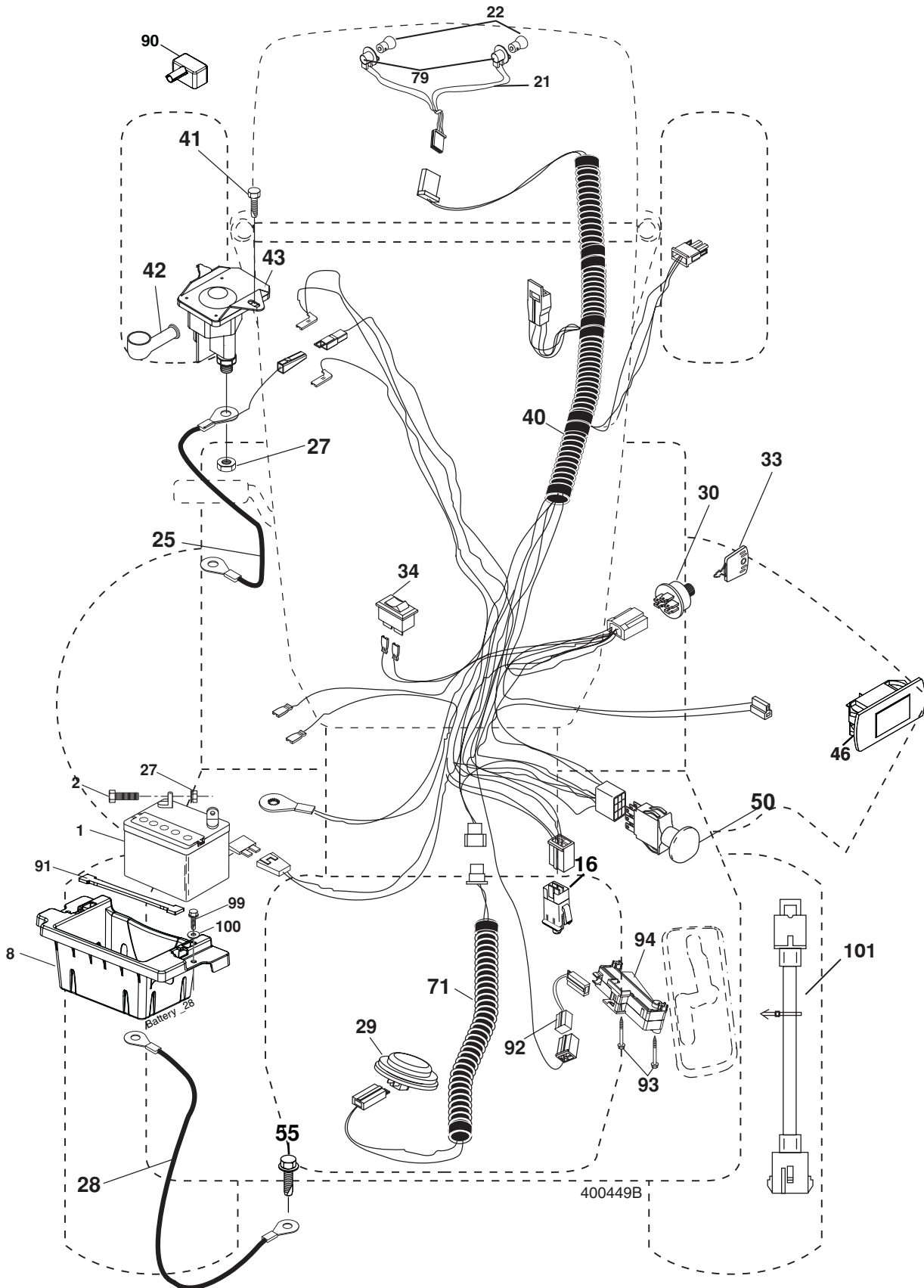

**TRACTOR - MODEL NO. M155107H (96041001000), PRODUCT NO. 960 41 00-10  
ELECTRICAL**

<b>KEY NO.</b>	<b>PART NO.</b>	<b>DESCRIPTION</b>
1	532 13 64-65	Battery
2	874 76 04-12	Bolt Hex Hd 1/4-20 unc x 3/4
8	532 19 32-28	Battery Box
16	532 17 61-38	Switch Interlock
21	532 17 56-88	Harness Socket Light
22	532 00 41-52	Bulb, Light # 1156
25	532 19 88-93	Cable Starter
26	532 17 51-58	Fuse
27	873 51 04-00	Nut Keps Hex 1/4-20 unc
28	532 19 88-85	Cable Ground
29	532 40 15-45	Switch Seat
30	532 19 33-50	Switch Ign
33	532 14 04-01	Key Ign Molded Generic
34	532 11 07-12	Switch Light/Reset
40	532 40 11-04	Harness Ign. Dash
41	817 72 04-08	Screw Thd Cut 1/4-20 x 1/2
42	532 13 15-63	Cover Terminal Red
43	532 19 25-07	Solenoid
46	532 40 17-63	Gauge Hourmeter
50	532 17 46-53	Switch PTO
55	817 06 05-12	Screw Thdrol 5/16-18 x 3/4
71	532 40 04-49	Harness Chassis
79	532 17 52-42	Socket Asm. Bulb
90	532 40 07-25	Cover Terminal Battery
92	532 19 66-15	Harness Pigtail Console ROS
93	532 19 25-40	Screw Plastite 10-14 x 2.0
94	532 19 18-34	Module Reverse ROS
101	532 19 83-17	Pigtail Harness Clutch

**NOTE:** All component dimensions given in U.S. inches  
1 inch = 25.4 mm

# TRACTOR - MODEL NO. M155107H (96041001000), PRODUCT NO. 960 41 00-10 CHASSIS

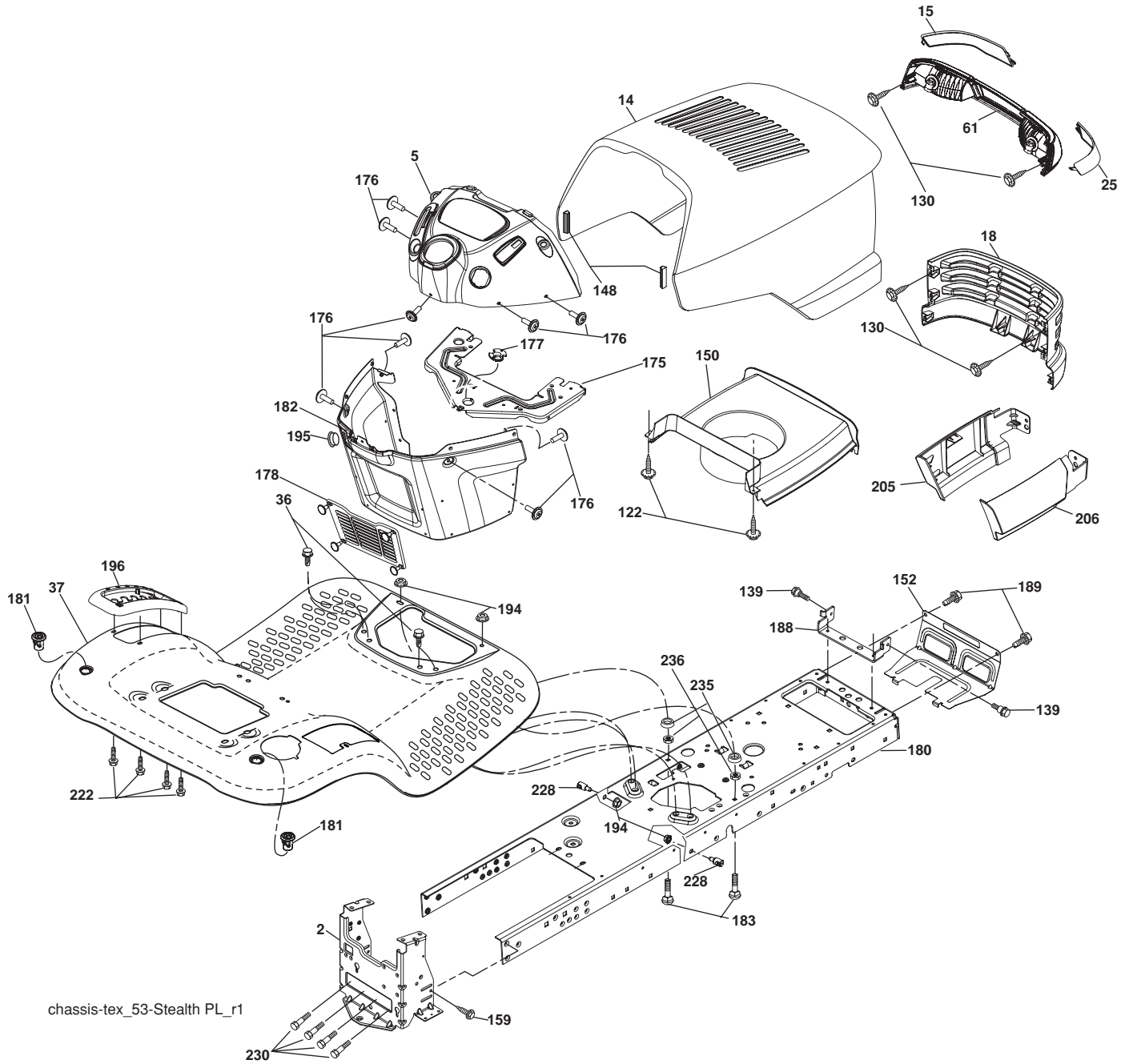

**TRACTOR - MODEL NO. M155107H (96041001000), PRODUCT NO. 960 41 00-10  
CHASSIS**

KEY NO.	PART NO.	DESCRIPTION
2	532 19 42-63	Drawbar
5	532 41 14-10	Dash
7	532 19 65-39	Bolt Shoulder
14	532 19 49-77	Hood
15	532 16 18-41	Lens LH
18	532 18 71-14	Grille
25	532 16 18-42	Lens RH
36	817 06 05-12	Screw 5/16-18 x 3/4
37	532 41 17-09	Fender
61	532 17 97-63	Light Asm Dual
122	532 19 25-12	Screw 10-32 x 5/8
130	532 19 16-11	Screw 10 x 3/4 Single Lead-Hex
139	532 17 18-73	Bolt Shoulder 5/16-18
148	532 16 46-55	Bumper Extrusion
150	532 19 03-08	Air Duct
152	532 19 43-29	Shield Browning
159	817 00 06-12	Screw 3/8-16 x 3/4
175	532 19 32-36	Crossmember
176	532 40 07-76	Screw 10-24 x 5/8
177	532 19 52-27	Bushing Steering
178	532 19 56-51	Cargo Net Asm.

KEY NO.	PART NO.	DESCRIPTION
180	532 19 42-60	Chassis
181	532 40 47-96	Bushing Mtg. Fender Crgo
182	532 19 25-51	Dash Lower
183	874 78 05-20	Bolt Fin Hex 5/16-18 unc x 1-1/4
188	532 19 43-16	Bracket Pick-Off Hood
189	817 00 05-12	Screw 5/16-18 x 3/4
194	873 90 05-00	Nut Lock Hex Flange 5/16-18
195	532 40 41-37	Plug Hole Dash Lower
196	532 41 05-84	Console Asm. Deck Lift
205	532 18 71-12	Skirt Hood Side LH
206	532 18 71-11	Skirt Hood Side RH
222	532 13 77-29	Screw Thdrol 1/4-20 x 5/8
228	532 19 51-61	Stud Fastner
230	532 17 01-65	Bolt Shoulder 5/16-18
235	532 40 61-29	Spacer Fender
236	873 93 05-00	Nut Lock 5/16-18 UNC
--	532 41 17-08	Plug Dash
--	532 41 14-11	Plug Cruise Control

**NOTE:** All component dimensions given in U.S. inches  
1 inch = 25.4 mm

# TRACTOR - MODEL NO. M155107H (96041001000), PRODUCT NO. 960 41 00-10 DRIVE

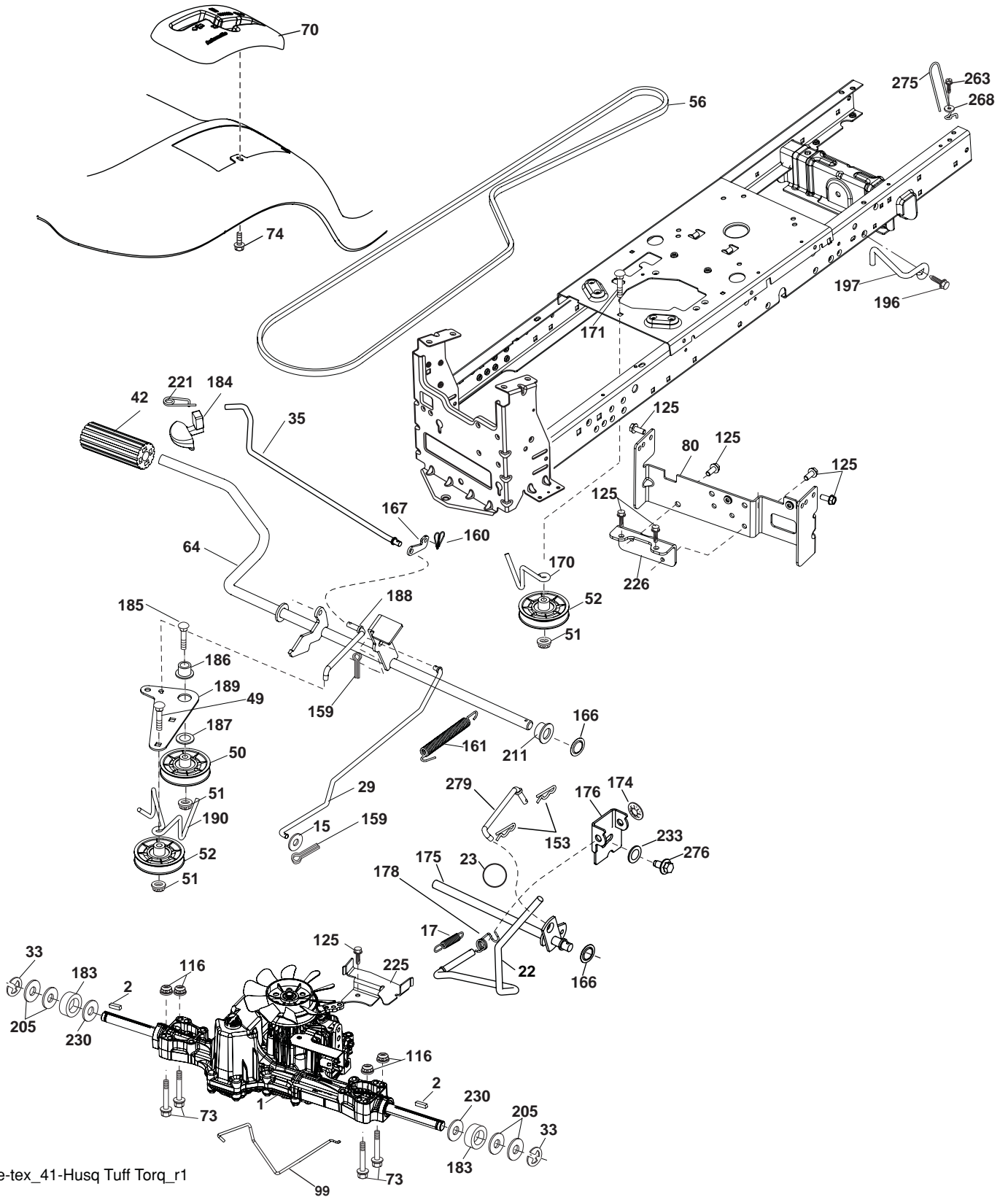

drive-tex\_41-Husq Tuff Torq\_r1



**TRACTOR - MODEL NO. M155107H (96041001000), PRODUCT NO. 960 41 00-10  
DRIVE**

KEY NO.	PART NO.	DESCRIPTION
1	<b>532 40 82-14</b>	Transaxle, TUFFTORQ K46
2	532 12 35-83	Key
15	819 13 13-16	Washer 13/32 x 13/16 x 16 Ga.
17	<b>532 41 36-78</b>	Spring, Brake
22	532 19 76-60	Rod Shift
23	532 41 14-00	Knob
29	532 40 38-06	Rod, Brake
33	812 00 00-01	Ring E
35	532 19 72-75	Rod, Brake, Park
42	532 12 48-72	Cover, Foot Pedal
49	872 11 06-14	Bolt
50	532 19 43-27	Pulley Idler Flat
51	873 90 06-00	Lock Nut 3/8-16
52	532 19 43-26	Idler V-Groove 910" Offset
56	532 13 09-69	V-Belt, Drive
64	532 19 62-00	Shaft Asm. Pedal Brake Control
70	532 41 13-29	Console
73	874 49 05-44	Bolt Hex Flghd 5/16-18 Gr. 5
74	532 14 24-32	Screw 1/4 x 1/2
80	<b>532 41 21-70</b>	Strap Torque
99	<b>532 40 59-03</b>	Rod Bypass
116	873 90 05-00	Nut Lock Hex Flange 5/16-18
125	817 00 05-12	Screw 5/16-18 x 3/4
153	532 12 47-88	Retainer Spring
159	876 02 04-12	Pin Cotter 1/8 x 3/4
160	532 16 94-84	Retainer Clip
161	532 19 54-03	Spring, Return, Clutch
166	532 19 72-90	Nut Push
167	532 40 52-57	Latch Brake Parking
170	532 19 43-22	Keeper Belt Centerspan
171	872 11 06-16	Bolt RDHD SQNK 3/8-16UNC x 2

KEY NO.	PART NO.	DESCRIPTION
174	532 19 72-89	Nut Push
175	532 40 62-08	Shaft Asm Shift
176	532 19 62-14	Arm Clevis Rod Shift
178	532 19 74-56	Spring Shift
183	532 13 70-57	Spacer Split
184	532 41 17-16	Handle Parking Brake
185	872 11 06-20	Bolt Rdhd Sqnk 3/8-16 x 2-1/2
186	532 19 43-21	Spacer Retainer
187	819 13 32-10	Washer
188	532 19 43-23	Link Clutch Ground Drive
189	532 19 43-17	Bellcrank Ground Drive
190	532 19 43-18	Keeper Bellcrank Ground Drive
196	817 00 06-16	Screw 3/8-16 x 1
197	532 19 58-04	Bracket Clutch Anti-Rotation
205	532 12 17-48	Washer
211	532 19 62-12	Bushing Brake Shaft
221	532 40 31-87	Retainer Spring Clip Handle
225	532 40 33-19	Keeper Belt Trans.
226	532 40 15-64	Bracket Mount Touque
230	532 18 89-67	Washer Hardened
233	532 40 52-96	Washer Serrated
268	819 13 16-14	Washer 13/32 x 1 x 14 Ga.
275	532 18 24-02	Guard Muffler
276	874 78 07-16	Bolt 7/16-14 x 1 Gr. 5
279	532 40 62-07	Link Shift
263	817 00 06-12	Screw 3/8-16 x 3/4

NOTE: All component dimensions given in U.S. inches  
1 inch = 25.4 mm

# TRACTOR - MODEL NO. M155107H (96041001000), PRODUCT NO. 960 41 00-10

## STEERING ASSEMBLY

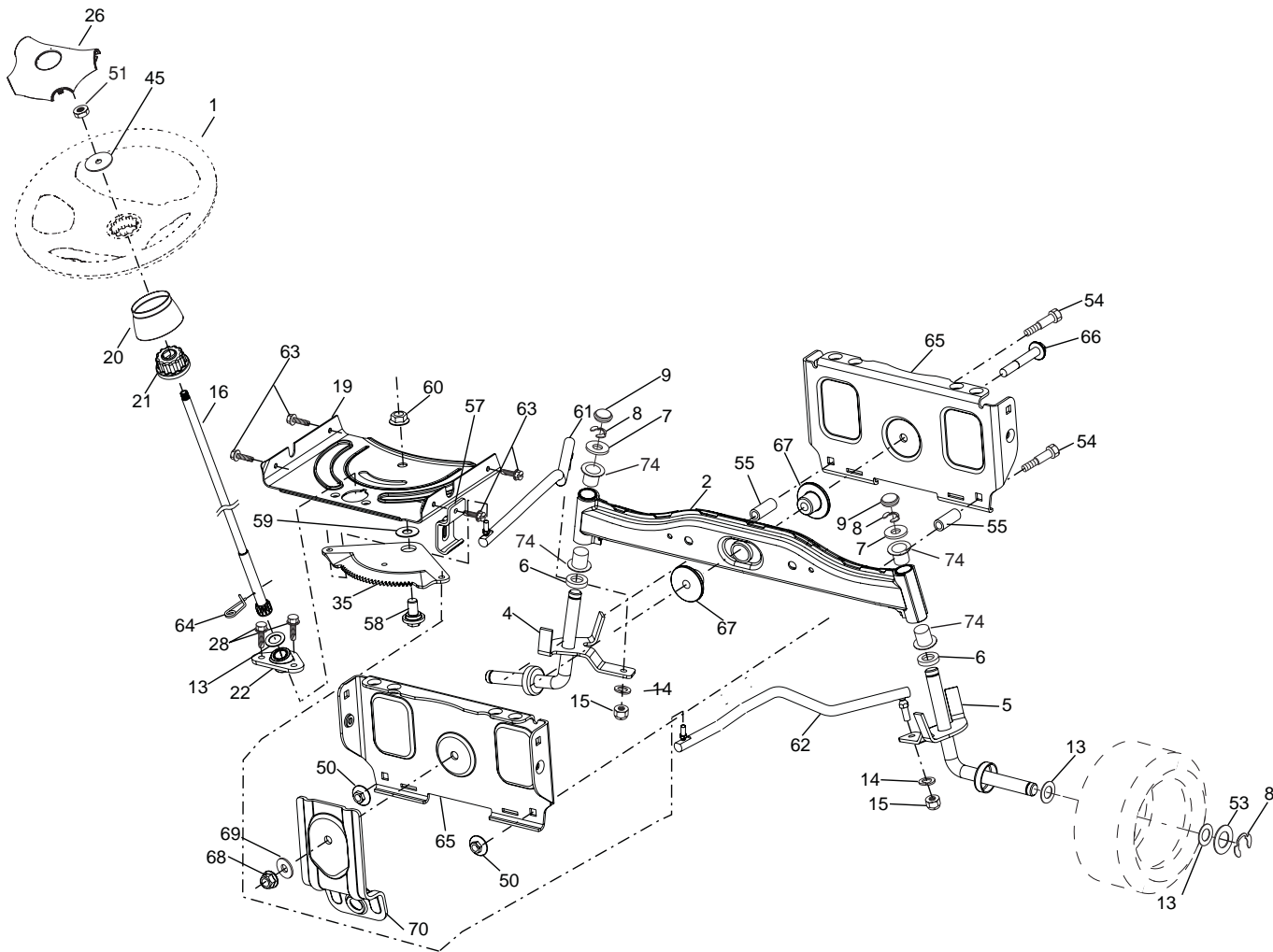

steering-tex\_4-1t

KEY NO.	PART NO.	DESCRIPTION
1	532 19 45-95	Wheel, Steering
2	532 19 56-73	Axle Asm., Front
4	532 40 30-87	Spindle Asm., LH
5	532 40 30-88	Spindle Asm., RH
6	532 12 49-31	Bearing, Race Thrust Harden
7	532 12 17-48	Washer 25/32 x 1-5/8 x 16 Ga.
8	812 00 00-29	Ring, Klip #T5304-75
9	532 12 12-32	Cap, Spindle
13	532 12 17-49	Washer 25/32 x 1-1/4 x 16 Ga.
14	810 04 06-00	Washer, Lock Hvy Hlcl Spr 3/8
15	873 54 06-00	Nut, Crown Lock 3/8-24 unf
16	532 19 47-46	Shaft Steering
19	532 19 47-29	Plate Steering
20	532 41 14-25	Boot Steering
21	532 18 67-37	Adapter, Wheel Steering
22	532 19 48-45	Bushing, Strg. Blk
26	532 19 46-03	Insert, Wheel Steering
28	817 00 06-12	Screw 3/8-16 x 3/4
35	532 19 47-32	Gear, Sector Plate
45	819 11 38-12	Washer 11/32 x 2-3/8 x 12 Ga
50	873 90 06-00	Nut Lock 3/8-16 UNC
51	873 94 08-00	Nut Hex Jam Toplock 1/2-20 unf

KEY NO.	PART NO.	DESCRIPTION
53	532 18 89-67	Washer Hardened .793 x 1.637 x .060
54	874 76 06-36	Bolt 3/8-16 UNC x 2-1/4
55	532 19 76-36	Spacer Brace Axle
57	532 40 74-65	Bracket Upstop
58	532 19 47-47	Bolt Shoulder Sector Pivot CFM
59	532 19 47-48	Washer Thrust Sector Steering
60	873 97 10-00	Nut Flange Lock 5/8-11
61	532 19 47-40	Draglink LH
62	532 19 47-41	Draglink, RH
63	817 00 05-12	Screw 5/16-18 x 3/4
64	532 19 98-49	Retainer Clip Spring Steering
65	532 19 47-34	Brace Axle Front
66	871 02 07-48	Bolt Hex Fghd 7/16-14 x 3 Serr
67	532 19 47-37	Bushing PM Front Axle
68	873 90 07-00	Nut Lock Flange 7/16-14 Gr. 5
69	532 19 91-62	Washer 1.5 x .505 x .118
70	532 19 61-97	Bracket Deck Susp. Front
74	532 12 49-37	Bearing

**NOTE:** All component dimensions given in U.S. inches  
1 inch = 25.4 mm

**TRACTOR - MODEL NO. M155107H (96041001000), PRODUCT NO. 960 41 00-10  
SEAT ASSEMBLY**

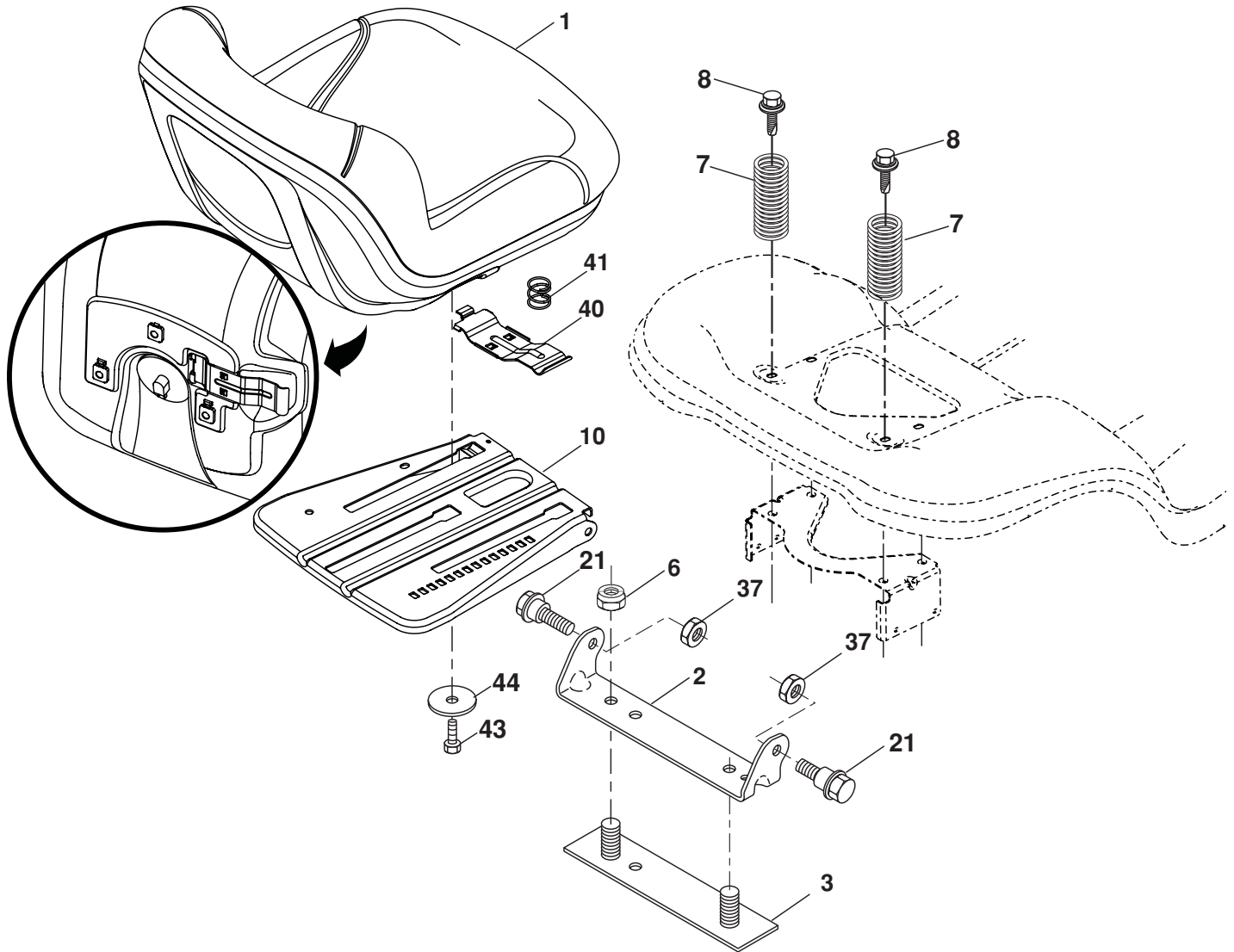

seat-tex\_7-vgt

KEY NO.	PART NO.	DESCRIPTION
1	532 19 75-11	Seat
2	532 18 01-66	Bracket Pivot Fender
3	532 14 06-75	Strap, Asm Fender
6	873 80 06-00	Nut, Lock W/Ins. 3/8-16 unc
7	532 12 41-81	Spring, Seat Cprsn
8	532 17 18-77	Bolt 5/16-18 uncx 3/4 w/Sems
10	532 19 69-77	Pan, Seat
21	532 17 18-52	Bolt, Shoulder 5/16-18

KEY NO.	PART NO.	DESCRIPTION
37	873 80 05-00	Nut, Lock 5/16-18 unc
40	532 19 76-61	Handle Slide Seat
41	532 19 82-00	Spring Latch Seat
43	874 76 06-12	Bolt 3/8-16 x 3/4
44	819 13 38-12	Washer 13/32 x 2-3/8 x 12 Ga.

**NOTE:** All component dimensions given in U.S. inches  
1 inch = 25.4 mm

**TRACTOR - MODEL NO. M155107H (96041001000), PRODUCT NO. 960 41 00-10  
ENGINE**

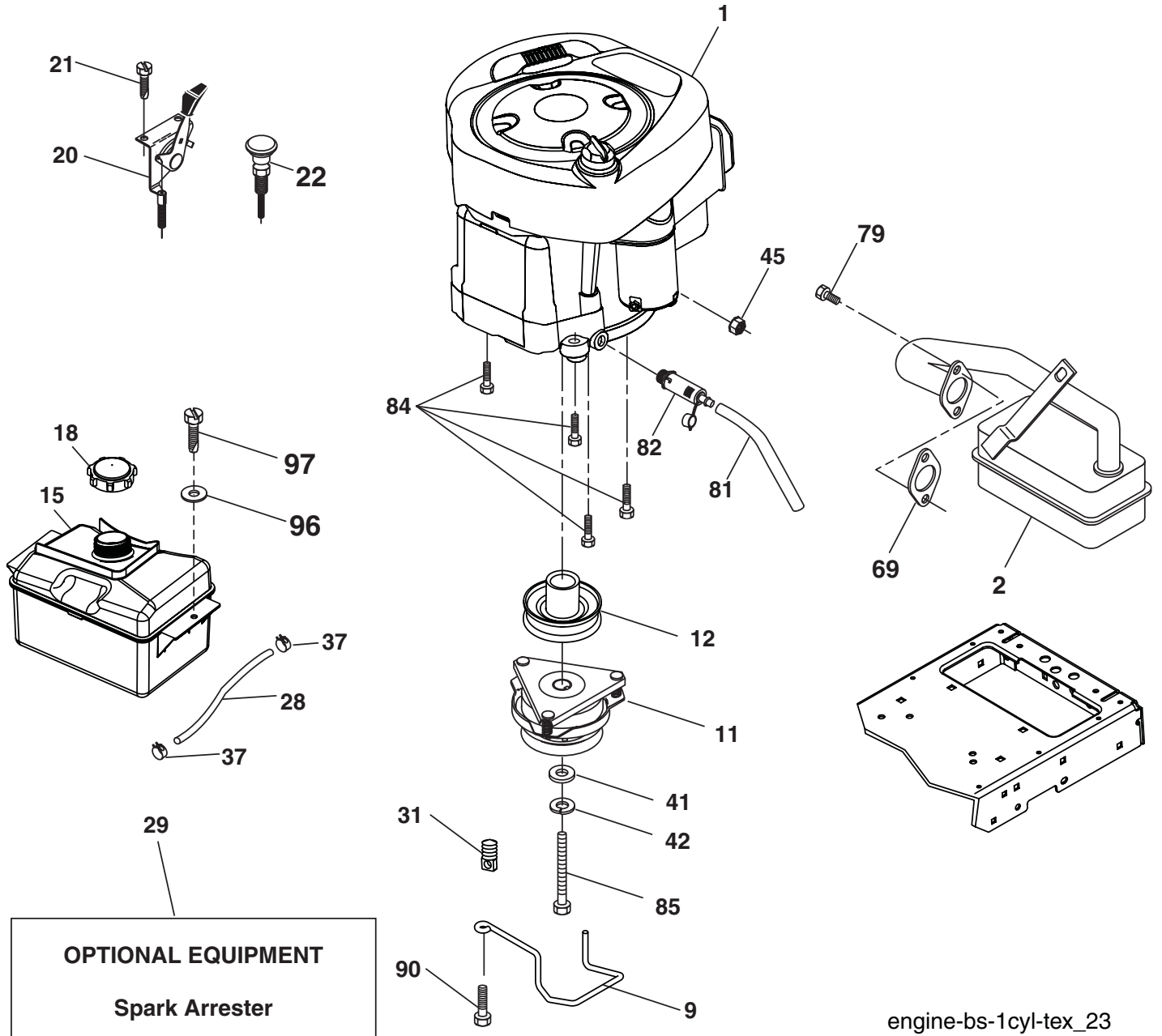

**TRACTOR - MODEL NO. M155107H (96041001000), PRODUCT NO. 960 41 00-10  
ENGINE**

KEY NO.	PART NO.	DESCRIPTION
1	-----	Engine Briggs Model No. 31A607
2	532 13 73-52	Muffler
9	532 19 43-20	Keeper Belt Engine
11	532 18 05-05	Clutch Electric
12	532 40 50-97	Pulley Engine
15	532 40 75-16	Tank Fuel
18	532 19 77-25	Cap Asm
20	532 41 17-24	Control Throttle
21	532 19 16-11	Screw 10 x 3/4 Single Lead Hex
22	532 41 17-25	Control Choke
28	532 13 70-40	Fuel Line
29	532 13 71-80	Spark Arrester Kit
31	532 14 50-06	Clip Push-In
37	532 12 34-87	Clamp Hose
41	532 12 61-97	Washer 1-1/2 OD x 15/32 ID x .250
42	810 04 07-00	Washer Lock 7/16
45	873 51 04-00	Nut Keps Hex 1/4-20 unc
69	532 16 52-91	Gasket
79	532 19 23-34	Screw 5/16-18 x .75
81	532 14 84-56	Tube Drain Oil Easy
82	532 18 16-54	Plug Drain Oil
84	817 06 06-20	Screw 3/8-16 x 1-1/4
85	532 17 39-37	Bolt 7/16-20 x 4
90	817 00 06-16	Screw 3/8-16 x 1
96	<b>19091416</b>	Washer 9/32 x 7/8 x 16 GA
97	<b>17670412</b>	Screw 1/4 - 20 x 3/4

**NOTE:** All component dimensions given in U.S. inches  
1 inch = 25.4 mm

For engine service and replacement parts, call the toll free number for your engine manufacturer listed below:

Briggs & Stratton            1-800-233-3723

**Engine Power Rating Information**

The gross power rating for individual gas engine models is labeled in accordance with SAE (Society of Automotive Engineers) code J11940 (Small Engine Power & Torque Rating Procedure), and rating performance has been obtained and corrected in accordance with SAE J1995 (Revision 2002-5). Actual gross engine power will be lower and is affected by, among other things, ambient operating conditions and engine-to-engine variability. Given both the wide array of products on which engines are placed and the variety of environmental issues applicable to operating the equipment, the gas engine will not develop the rated gross power when used in a given piece of power equipment (actual "on-site" or net horsepower). This difference is due to a variety of factors including, but not limited to, accessories (air cleaner, exhaust, charging, cooling, carburetor, fuel pump, etc.), application limitations, ambient operating conditions (temperature, humidity, altitude), and engine-to-engine variability. Due to manufacturing and capacity limitations, Briggs & Stratton may substitute an engine of higher rated power for this Series engine.



**TRACTOR - MODEL NO. M155107H (96041001000), PRODUCT NO. 960 41 00-10  
MOWER DECK**

KEY NO.	PART NO.	DESCRIPTION
1	532 19 64-95	Mower Housing
6	532 19 51-86	Arm Suspension
8	532 19 30-03	Bolt/Washer asm 7/16-20 unf
11	532 13 41-49	Blade
13	532 19 28-72	Shaft Assembly, Mandrel
14	532 18 72-81	Housing, Mandrel
15	532 11 04-85	Bearing, Ball, Mandrel
16	532 17 44-93	Stripper, Mower Deck
19	532 19 65-39	Bolt, Shoulder
20	532 15 97-70	Baffle, Vortex
21	873 68 05-00	Nut, Crownlock 5/16-18 unc
23	532 19 25-57	Bracket, Deflector
24	532 10 53-04	Cap, Sleeve
25	532 19 70-26	Spring, Torsion, Deflector
26	532 11 04-52	Nut, Push
27	532 40 30-04	Shield, Deflector
29	532 13 14-91	Rod, Hinge
30	532 17 39-84	Screw Thdrol Rolling Wsh Hd
31	532 18 76-90	Washer, Spacer
32	532 15 35-35	Pulley, Mandrel
33	532 40 02-34	Nut, Toplock, Flanged
34	872 11 06-12	Bolt Carr Sh. 3/8-16 x 1-1/2 Gr. 5
36	532 19 31-97	Pulley, Idler, Primary
40	873 90 06-00	Nut, Lock Flg. 3/8-16 unc
55	532 19 72-49	Arm, Idler
56	532 19 90-92	Spacer, Retainer

KEY NO.	PART NO.	DESCRIPTION
57	817 00 06-16	Screw 3/8-16 x 1
59	532 14 10-43	Guard, Tuv Idler
68	532 14 49-59	V-Belt
69	872 14 05-05	Bolt
97	532 17 85-15	Washer, Flat Hardened
101	532 19 31-07	Cover Mulching
102	871 08 10-10	Screw 10-24 x 5/8
103	819 06 12-16	Washer #10
104	810 07 10-00	Washer Lock #10
105	532 16 07-93	Latch Asm
106	532 12 50-04	Nut Weld
116	532 12 48-42	Bolt, Shoulder
117	532 18 86-06	Wheel, Gauge
118	873 93 06-00	Nut, Lock 3/8-16 unc
119	819 12 14-14	Washer 3/8 x 7/8 x 14 Ga.
145	532 19 73-79	Pulley Idler
188	532 19 51-61	Stud Fastener
189	873 90 05-00	Nut Lock Hex Flange
190	532 19 72-51	Spring Mower Drive Electric
--	532 19 28-70	Mandrel Assembly (Includes housing, shaft and shaft hardware only-pulley not included)
--	532 40 94-87	Replacement Mower, Complete

**NOTE:** All component dimensions given in U.S. inches  
1 inch = 25.4 mm



**TRACTOR - MODEL NO. M155107H (96041001000), PRODUCT NO. 960 41 00-10  
MOWER LIFT**

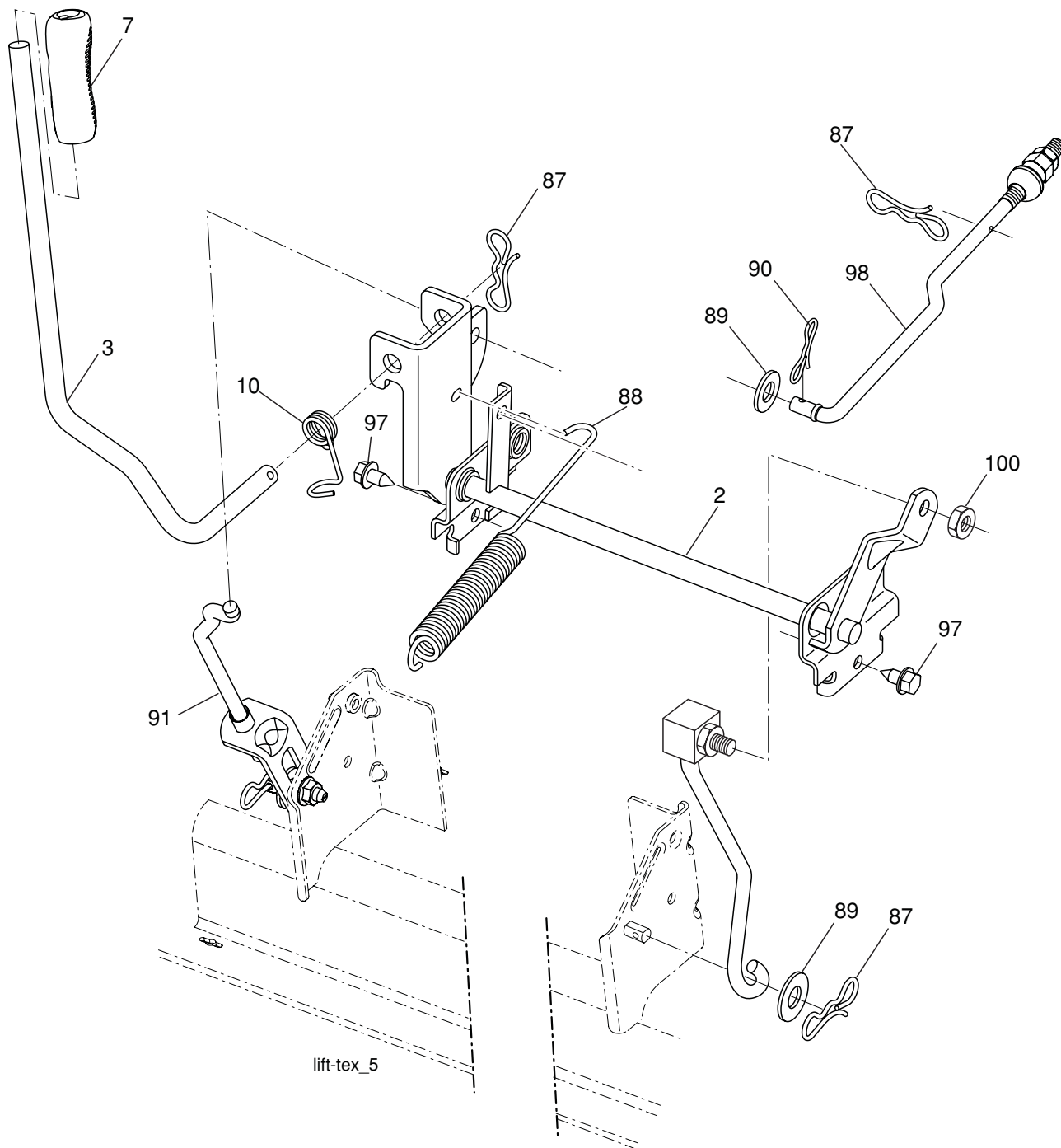

lift-tex\_5

KEY NO.	PART NO.	DESCRIPTION
2	532 19 52-23	Shaft Asm., Lift
3	532 19 52-31	Lever Asm., Lift
7	532 41 17-42	Grip, Lever
10	532 19 63-14	Spring Torsion
87	532 19 42-09	Pin Cotter 7/16 Bow Tie Lock
88	532 19 53-03	Spring Lift Assist
89	819 19 19-12	Washer Clear Zinc

KEY NO.	PART NO.	DESCRIPTION
90	532 19 42-08	Pin Cotter 5/16 Bow Tie Lock
91	532 19 51-81	Link Lift Susp Mower Rear
97	817 06 06-12	Screw 3/8-16 x .75 Smgml Tap/R.Z
98	532 19 52-70	Link Lift Susp. Front Mower
100	873 93 06-00	Nut Centerlock 3/8-16

**NOTE:** All component dimensions given in U.S. inches  
1 inch = 25.4 mm



---

# SERVICE NOTES

---

---

# SERVICE NOTES

---

---

# SERVICE NOTES

---



[www.mcculloch.biz](http://www.mcculloch.biz)