

# Electrolux

*Libretto d'istruzione e uso*  
*Notice d'instructions et mode d'emploi*  
*Instruction manual*  
*Bedienungsanleitung*  
*Manual de uso y manutencion*  
*Gebruiksaanwijzing*  
*Livro de instruções e modo de emprego*  
*Instrukcja obsługi i konserwacji*  
*Használati utasítás*  
*Návod k používání*  
*Brugsvejledning*  
*Bruksanvisning*  
*Bruks- og vedlikeholdsveiledning*  
*Käyttöohjeet*  
*Navodila za uporabo in vzdrževanje*  
*Εγχειρίδιο οδηγιών χρήσης*

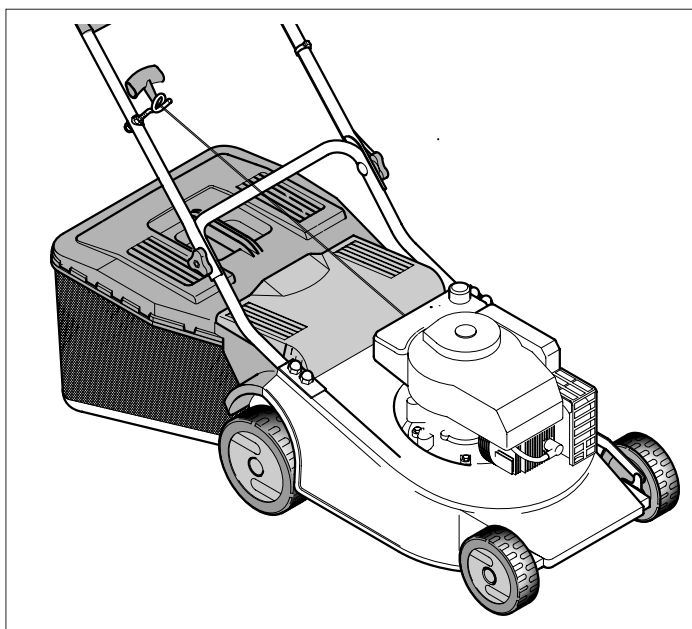

**Rasaerba con motore a scoppio - Lama 46 cm**  
**Tondeuse avec moteur thermique - Lame 46 cm.**  
**Lawn mower with petrol engine - 46 cm blade**  
**Rasenmäher mit Explosionsmotor - Messer 46 cm**  
**Cortadora de hierba con motor de explosión - Cuchilla 46 cm.**  
**Grasmaaimachine met verbrandingsmotor - Mes 46 cm.**  
**Cortagrama com motor a explosão - Lamina 46 cm.**  
**Kosiarka do trawy z silnikiem benzynowym - Noż 46 cm.**  
**Robbanò-motor hajtású fűnyíró - Kés 46 cm**  
**Sekačka na trávu se spalovacím motorem - žací nůž 46 cm**  
**Plæneklipper med benzinmotor - 46 cm klinge**  
**Gräsklippare med bensinmotor - 46cm kniv**  
**Gressklipper med benzinmotor - 46 cm kniv**  
**Räjähdysmoottorilla varustettu ruohonleikkuri - Terä 46 cm**  
**Motorna kosilnica - rezilo 46 cm.**  
**Χλοοκοπτική μηχανή με κινητήρα εσωτερικής καύσης - Μαχαιρί 46 cm.**

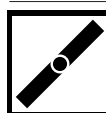

Rasaerba a spinta  
Tondeuse poussée  
Manual lawn mower  
Rasenmäher-Schiebegerät  
Cortadora de hierba de empuje  
Handmaaimachine  
Cortagrama de empurro  
Kosiarka do trawy  
Töbűnyíró  
Sekačka trávy ruční  
Plæneklipper skubbemodell  
Gräsklippare utan drivning  
Gressklipper uten drift  
Työnettävä ruohonleikkuri  
Rocna kosilnica  
*Χλοοκοπτική μηχανή με ώθηση*

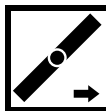

Rasaerba semovente  
Tondeuse tractée  
Self-propelled lawn mower  
Selbstfahrender Rasenmäher  
Cortadora de hierba propulsada  
Zelfrijdende grasmaaimachine  
Cortagrama semovente  
Kosiarka do trawy z napędem  
Őnjáró - fűnyíró  
Samohybná sekačka trávy  
Selvkørende plæneklipper  
Självgående gräsklippare  
Gressklipper med drift  
Itseliikkuva ruohonleikkuri  
Kosilnica na avtomatski pogon  
*Αυτοκίνητη χλοοκοπτική μηχανή*



Versione avviamento elettrico  
Tondeuse démarrage électrique  
Electric-start lawn mower  
Rasenmäher elektrischem Anlasser  
Cortadora arranque eléctrico  
Grasmaaimachine met elektrische ontsteking  
Cortagrama acionamento elétrico  
Kosiarka do trawy z napędem i zapłonem elektrycznym  
Villamos indítású - fűnyíró  
Sekačka trávy s elektrickým spoištínim  
Plæneklipper med elektrisk start  
Gräsklippare med elektrisk start  
Gressklipper med drift og elektrisk start.  
Itseliikkuva ruohonleikkuri  
Model na električni pogon  
*Εκδοχή με ηλεκτρική εκκίνηση*

*Il presente manuale rappresenta una parte integrante del prodotto. Vi preghiamo di conservarlo per ogni ulteriore utilizzo.*

*Le manuel présent fait partie intégrante du produit; nous vous prions en conséquence de le conserver pour toutes nécessités ultérieures.*

*The present manual constitutes an integral part of the product and it should be kept for all future reference. Das vorliegende Handbuch gehört zu einem festen Bestandteile des Produktes und muss deshalb zur Einsichtnahme sorgfältig aufgehoben werden.*

*El presente manual representa una parte integrante del producto. Les rogamos que lo conserven para cualquier ulterior empleo.*

*Deze handleiding is een integrerend deel van het product. Wij verzoeken u hem te bewaren voor iedere mogelijke nadere raadpleging*

*Este manual representa uma parte integrante do produto. Recomendamos guardá-lo para outros usos.*

*Niniejsza instrukcja stanowi integralną część produktu. Prosimy przechowywać ją do każdego dalszego użytkowania.*

*A jelen szakkönyv a termék szerves részét képezi. Kérjük megőrizni minden utólagos használatért.*

*Tato uživatelská příručka je neopomenutelnou součástí výrobku. Ušchovejte ji pro další použití.*

*Håndbogen er en integreret del af produktet. Den skal opbevares omhyggeligt for yderligere konsultation.*

*Denna manual utgör en integrerande del av produkten. Vi ber er spara den för senare bruk.*

*Dette håndboken representerer en fullende del av produkten. Det skal oppbevares for alle ytre anvendelser.*

*Tämä käyttöopas kuuluu olennaisena osana tuotteeseen. Säilytä se huolellisesti myöhempää käyttöä varten.*

*Navodila za uporabo in vzdrževanje so sestavni del izdelka, zato prosimo, da jih shranite in upoštevate za nadaljnjo uporabo.*

*To παρόν εγχειρίδιο αποτελεί ένα ολοκληρωτικό μέρος του προϊόντος. Σας παρακαλούμε να το φυλάξετε με προσοχή για κάθε περαιτέρω χρήση.*

I

F

GB

D

E

NL

P

PL

H

SK

CZ

DK

S

N

SF

SLO

GR



<b>A</b>	<b>DESCRIPTION</b> (starts at page 35)					
	1	Upper handles	7	Deck	13	Throttle lever
	2	Lower handles	8	Levers for adjusting the cutting heights	14	Engine stop lever
	3	Fastening knobs for upper handles	9	Spark plug	15	Reduction gear
	4	Grass catcher	10	Fuel cap	16	Console
	5	Oil filler cap	11	Engine start-grip	17	Ignition key
6	Oil drain plug	12	Rear deflector	18	Clutch lever	

**B C ASSEMBLY OF GRASS CATCHER** (starts at page 35)

Assemble with screws as shown.

**D ASSEMBLY REAR DEFLECTOR** (starts at page 35)

Assemble the spring into the rear deflector as shown in figure D1, insert the rod through the holes on the rear deflector and spring as shown in figure D2. Locate the rod into the mounting bracket as shown in figure D3, push down the spring as shown in figure D4 to locate it into the slot which tensions the rear deflector.



**E ASSEMBLY** (starts at page 36)



**Manual lawn mower**

Remove the bail arms, attach cables as shown and re-fit the bail arms, if applicable. Assemble the handle fit the levers with the pins and clips provided, assemble the wheels as shown and throttle if supplied.

**F ASSEMBLY** (starts at page 37)





**Self-Propelled/ Electric Start Lawnmower.**

Remove the bail arms, attach cables as shown and re-fit the bail arms, if applicable. Assemble the handle as shown.

**G ADJUSTMENT OF CUTTING HEIGHT** (starts at page 38)

**H SAFETY PRECAUTIONS** (starts at page 38)



- Always operate with the rear deflector or grass catcher in the correct position.
- Always stop the mower before removing the grass catcher or adjusting the height of cut.
- Never place your hands or feet underneath the deck or into the rear grass discharge chute while the mower is running.

**I** (starts at page 38)

Before mowing, remove all foreign objects from the lawn which may be thrown by the machine. While mowing, stay alert for any foreign objects which may have been missed. Never lift the rear of the mower while starting or during normal operation.

**J** (starts at page 38)

Never place your hands or feet underneath the deck or into the rear discharge chute while the mower is running.

**K OPERATION** (starts at page 39)

**ENGINE ADJUSTMENTS**

Refer to the engine manufacturer's maintenance manual.  
CAUTION:- 0.6l Oil must be added to the engine before use.

**L** (starts at page 39)

**STARTING THE ENGINE**

Once the machine has been set up properly, start the engine as follows:

a) *Engines with choke system:*  
when the engine is cold, position the accelerator lever (13) on START

b) Operate the engine stop lever (14) to prepare the engine for start, keep lever pressed against handle while starting and using the machine - it operates the engine brake.

c) *Engines with primer system:*  
Press the fuel-enrichment pump (Picture 'L' item 31) located on the carburettor 3 or 4 times position the accelerator lever (13) on MAX.  
For further information and explanations, read carefully the user instruction manual of the engine.

d) Start engine.  
**MANUAL STARTING:** (While holding the engine stop lever (14)).  
• Hold the engine start-grip (11) and pull the starter rope gently until you feel the resistance caused by compression. Return the starter rope slowly then pull the handle firmly towards you to its full extent.

**M** (starts at page 39)

**ELECTRICAL STARTING:**

- Insert the plug (G) in the socket (H) on the engine. While holding the engine stop lever (14). Turn the ignition key (17).

**CAUTION:** The blade starts turning as soon as the engine is started.

**N** (starts at page 39)





Keep the engine stop lever (14) depressed during machine operation. When the lever is released, the engine stops.

**MOWING**

To cut the grass, push the lawn mower manually

**O** (starts at page 39)

Keep the engine stop lever (14) depressed during machine operation. When the lever is released, the engine stops.

**MOWING**

To cut the grass, push the lawn mower manually or insert the automatic advance gear.

**How to insert automatic advance:** Lift up the clutch handle (18) and keep it pressed in position.  
**CAUTION:** Engage the gear only when the engine is running.

**How to disengage advance:** Release the clutch handle.

**P** (starts at page 39)

**Important:** If, when you press the clutch lever, the automatic advance gear does not engage, the clutch cable should be adjusted by inserting the spring (P) in one of the subsequent holes in the plate (R) (or in the hole "S").



**Q** **AUTOMATIC ADVANCEMENT** (starts at page 39)

Periodically check the automatic advance assembly and make sure to keep it clean. In particular, the pinion (19) and the gear (20) must be kept perfectly clean. To carry out this check, you must remove the wheel (21) by unscrewing the screw (22).

**SAFETY RULES****Training**

- a) Persons under 16 years of age and persons who are not familiar with the user instructions must not use the lawn mower.
- b) The operator is responsible for the safety of other people in the working area. Keep children and domestic animals at a safe distance when the lawn mower is in use.
- c) This machine is to be used exclusively for cutting natural grass. Never use the mower for other purposes (e.g., for flattening out bumps in the ground, such as mole-hills or ant-hills).
- d) Work only when there is sufficient light.
- e) Before mowing, remove all foreign objects from the lawn which may be thrown by the machine. While mowing, stay alert for any foreign objects which may have been missed.

**Setting up and operating the lawn mower**

- a) When mowing, wear strong footwear (boots or heavy shoes) and long trousers.
  - b) Before you start mowing, make sure that the blade and blade fixing screw are securely fastened. If the blade is damaged, it must be replaced.
  - c) Turn off the engine, wait until the blade has stopped and remove the spark plug cap before:
    - transporting, lifting or moving the machine away from the working area;
    - carrying out maintenance or cleaning, or when carrying out any operation on the blade;
    - adjusting the cutting height;
    - leaving the machine unattended.
- Caution! The blade starts turning as soon as the engine is started**
- d) **Caution!** The fuel is highly inflammable:
    - Store fuel in containers specifically designed for this purpose.
    - Refuel outdoors only and do not smoke while refuelling.

- Fill up the fuel tank before starting the engine. Under no circumstances open the fuel tank cap or add petrol when the engine is running or when it is still hot.
- If the petrol has overflowed, do not under any circumstances start up the engine. Move the mower away from the area where fuel has been spilt and avoid any source of possible ignition until the petrol fumes have dissipated.
- Replace the fuel tank cap and tighten it down firmly.
- e) Do not operate the engine in a confined space where dangerous carbon monoxide fumes can collect.
- f) When mowing, never run; you must always walk.
- g) Exercise extreme caution when turning or when pulling the lawn mower towards you.
- h) Particular precautions must be taken when mowing on slopes or downhill stretches:
  - Use appropriate antislip footwear.
  - Always be sure of your footing.
  - Mow across the face of slopes, never up or down.
  - Take great care when changing direction.
  - Do not mow on excessively steep slopes.
- i) Never use the lawn mower unless the guards and safety devices (e.g. deflector, grass catcher) are securely in position and in good condition.
- j) Ensure that the grass catcher and deflector are correctly located. Failure to do so may result in foreign objects being ejected by the blade.
- k) For reasons of safety, the engine must never exceed the speed. (r.p.m.) indicated on the label.
- l) Take care when starting the engine and be sure to follow the user instructions. Never place your hands or feet underneath the deck or into the rear discharge chute while the engine is running.
- m) Never lift the rear of the mower while starting the engine

or during normal operation.

- n) If the blade happens to hit any obstacle, stop the engine at once and remove the spark plug cap. Then get an expert to examine the blade.

**Maintenance and storage**

- a) Make sure that all nuts, bolts, and screws are kept well tightened to keep the mower in a safe operating condition.
- b) Never leave the machine with fuel in the tank within an enclosed area where the fuel vapours could reach naked flames or sparks.
- c) Allow the engine to cool before storing in any enclosure.
- d) Keep the engine, silencer, battery compartment and petrol tank free from grass, leaves and excess lubricant, in order to reduce the danger of fire.
- e) Frequently check the grass catcher for wear or deterioration
- f) For safety reasons, be sure to replace worn-out or damaged parts in due time.
- g) If the fuel tank has to be drained, it is essential that this be done outdoor.
- h) Assemble the blade following the corresponding instructions and use only blades bearing the maker's name or the trademark of the manufacturer or supplier and marked with the reference number.
- i) To protect hands during disassembly or assembly of the blades, it is absolutely essential to wear suitable protective gloves.

**MAINTENANCE**

**Caution!** Switch off the motor and disconnect the spark plug before undertaking any maintenance work.

- For a four stroke engine, check the oil level and change the oil when dirty. For further explanation, see ENGINE INSTRUCTION BOOK.
- Frequently check the mower and ensure that all grass deposits are removed from beneath the deck.
- Never clean the mower by pouring water over it: this may seriously damage the electrical system.
- Take care, the exhaust muffler may be very hot.
- Frequently remove the wheel screws clean with petroleum and oil before replacing. Ball bearings must be greased before remounting.
- Frequently check the blade for damage.
- The lawn mower must be checked by a SERVICE DEALER.

**R** **BLADE** (starts at page 40)

- To remove the blade (23) unscrew the screw (24).
- Check the conditions of the blade-support (25), the washer (26), the key (27) and the washer (28) and replace any parts which are damaged.
- When reassembling, make sure that the key (27) is correctly seated in the shaft and that the cutting edges face in the direction of the engine rotation. The blade screw (24) must be torqued to 5,34 Kgm (52,4 Nm).

**S** **KIT ELECTRIC STARTING** (starts at page 40)

- Before starting the motor for the first time, you are advised to keep the battery on charge for 2 to 3 hours. If the battery proves to be low during starting, charge it for 24 hours. When starting, don't keep trying to start for more than 5 seconds.

**BATTERY MAINTENANCE****IMPORTANT**

For correct battery maintenance (29), especially in preparation for a long period of inactivity, and for recharging, it is not necessary to remove it from its casing, but to simply proceed as follows:

- 1) Remove contact (30).
- 2) Store the battery in a fresh and dry place.
- 3) Recharge the battery before use at room temperature for 24-36 hours.
- 4) Restore the contact (30) before use.

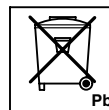
**BATTERY DISPOSAL**

Those batteries marked with a "crossed out waste disposal bin" and bearing the chemical symbol Pb (battery containing lead) are not to be disposed in domestic waste bins.



The user is legally obliged to take the used batteries to special collection points or to return them to the retailer.

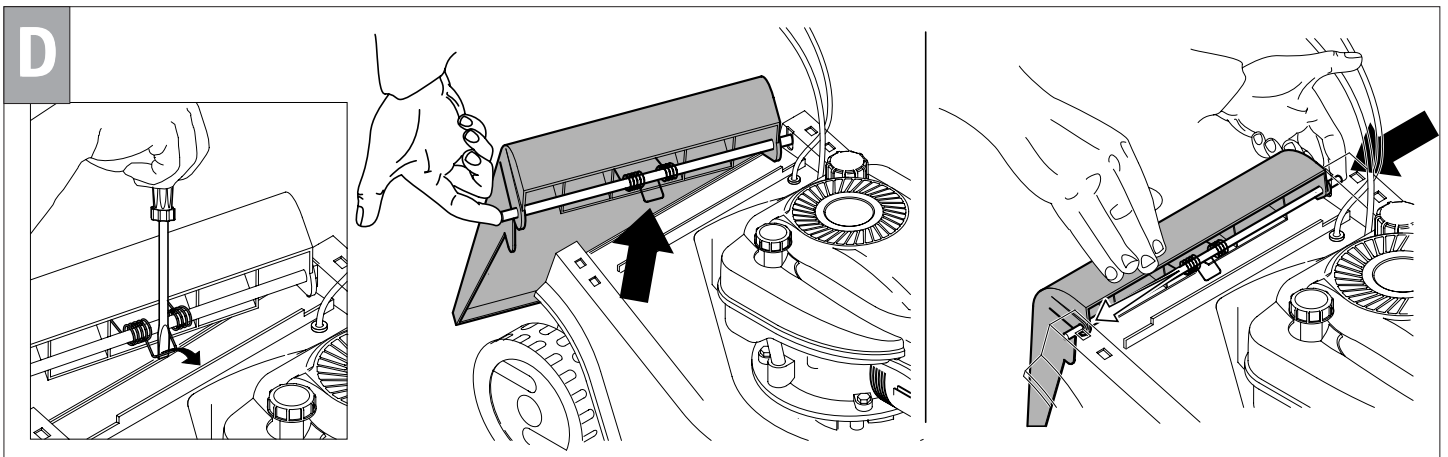
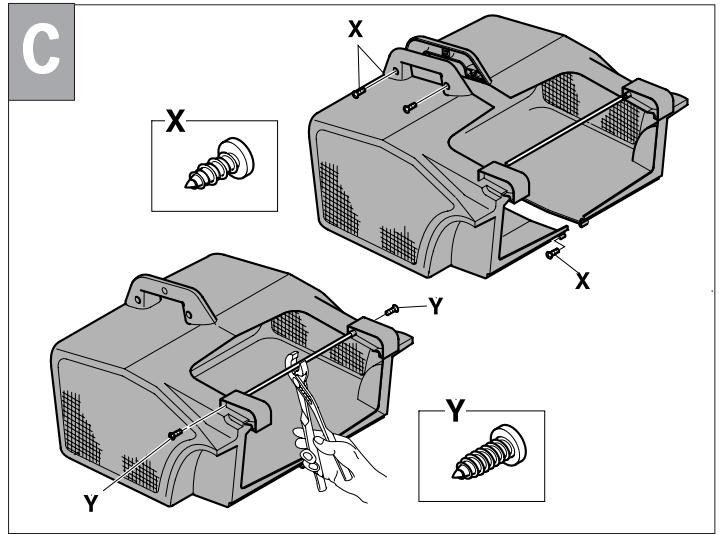
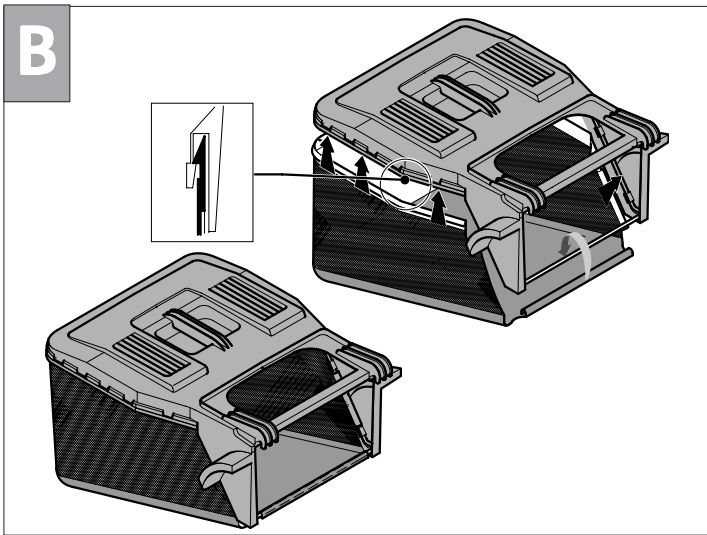
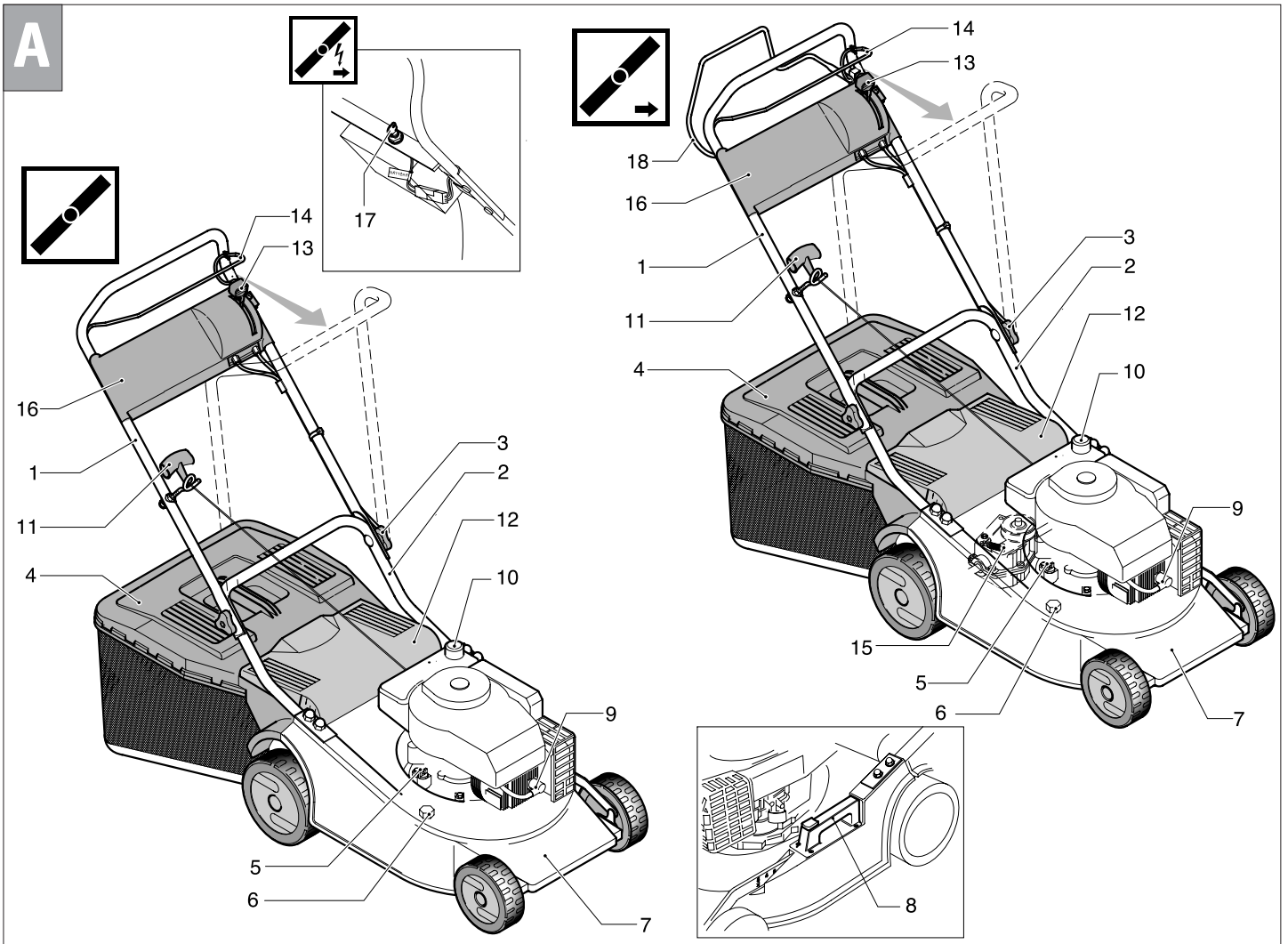

E

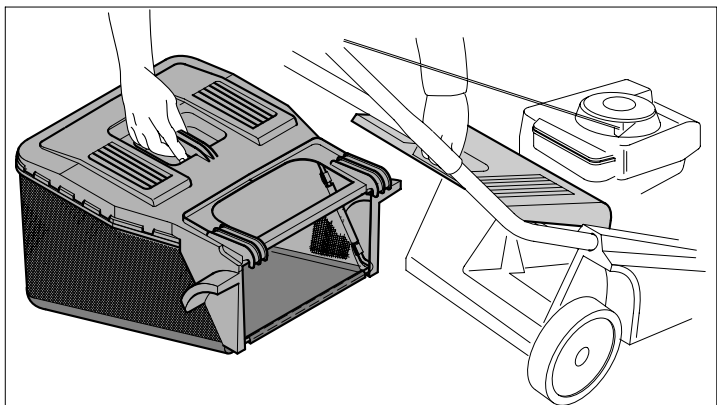
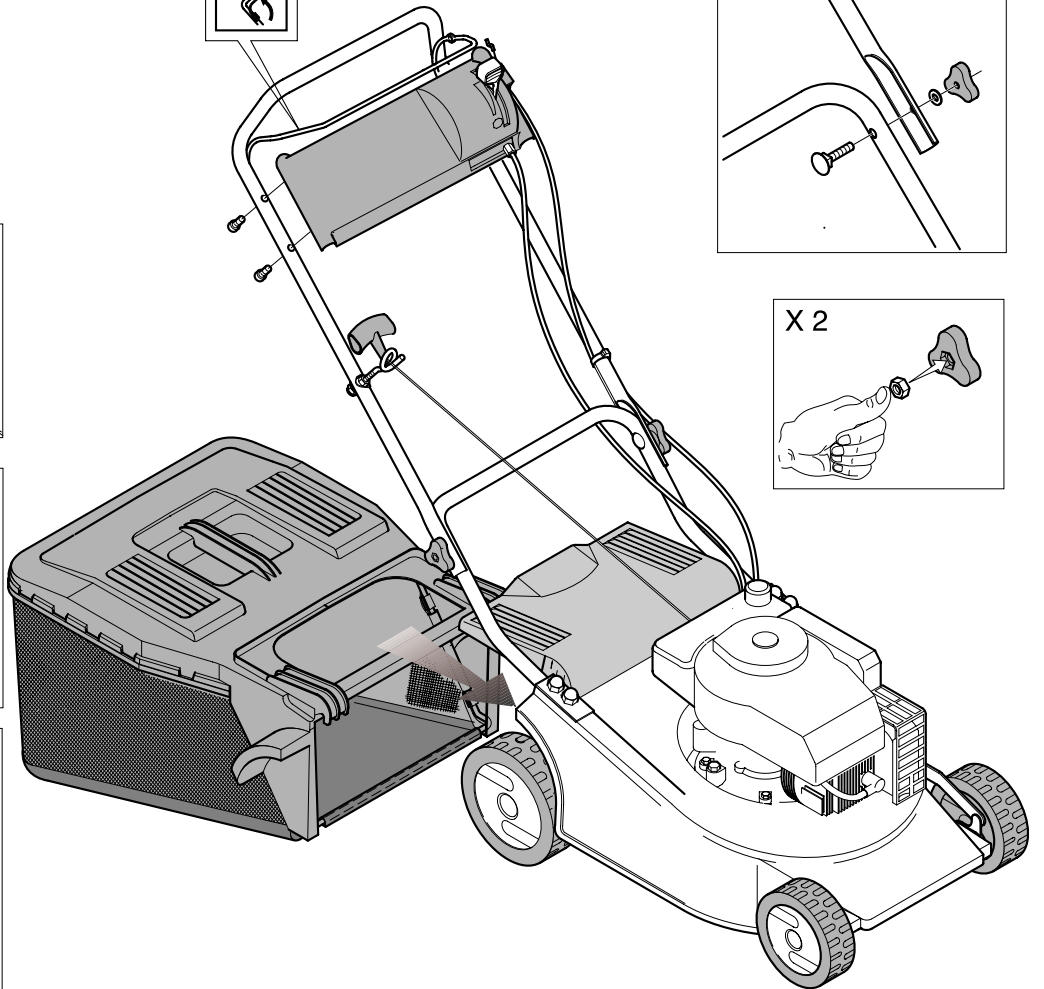
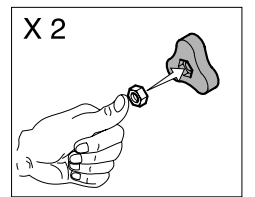
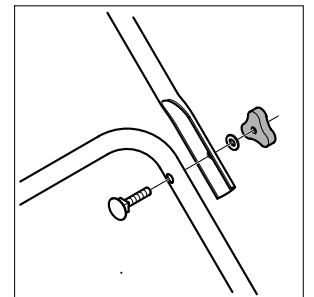
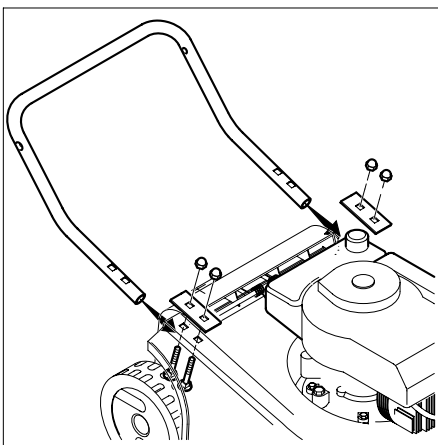
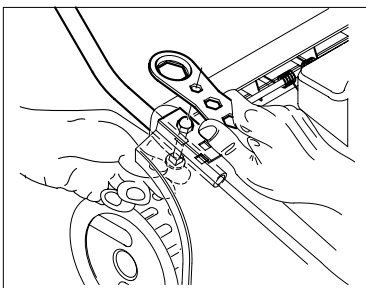
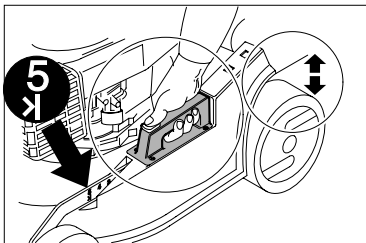
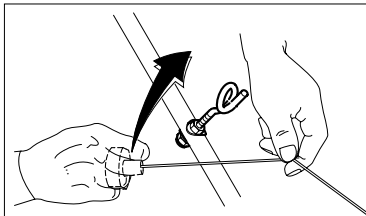
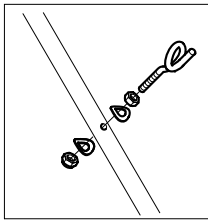
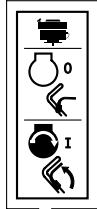
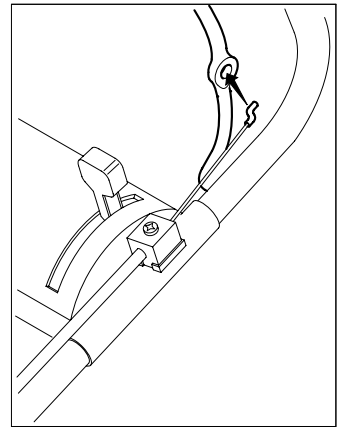
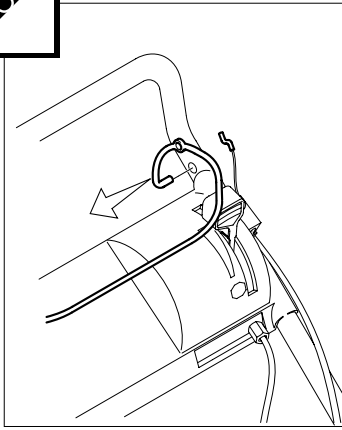



F

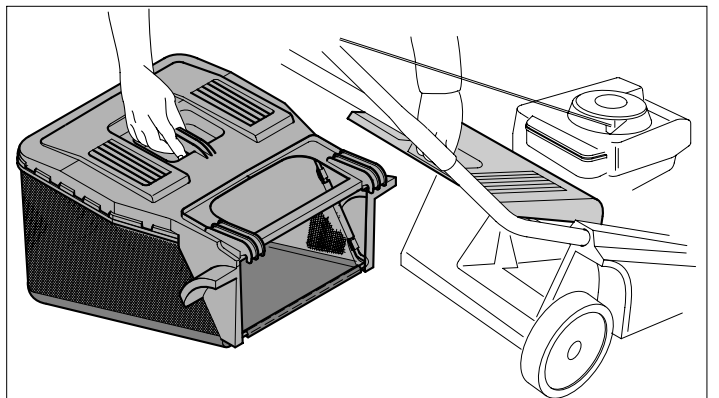
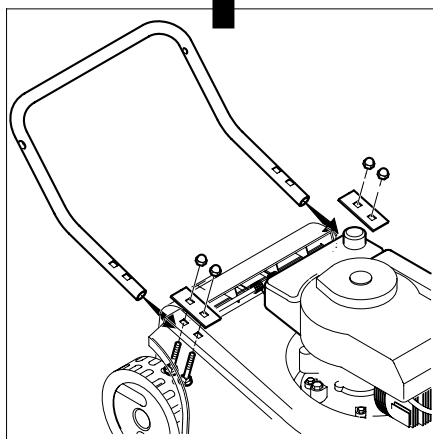
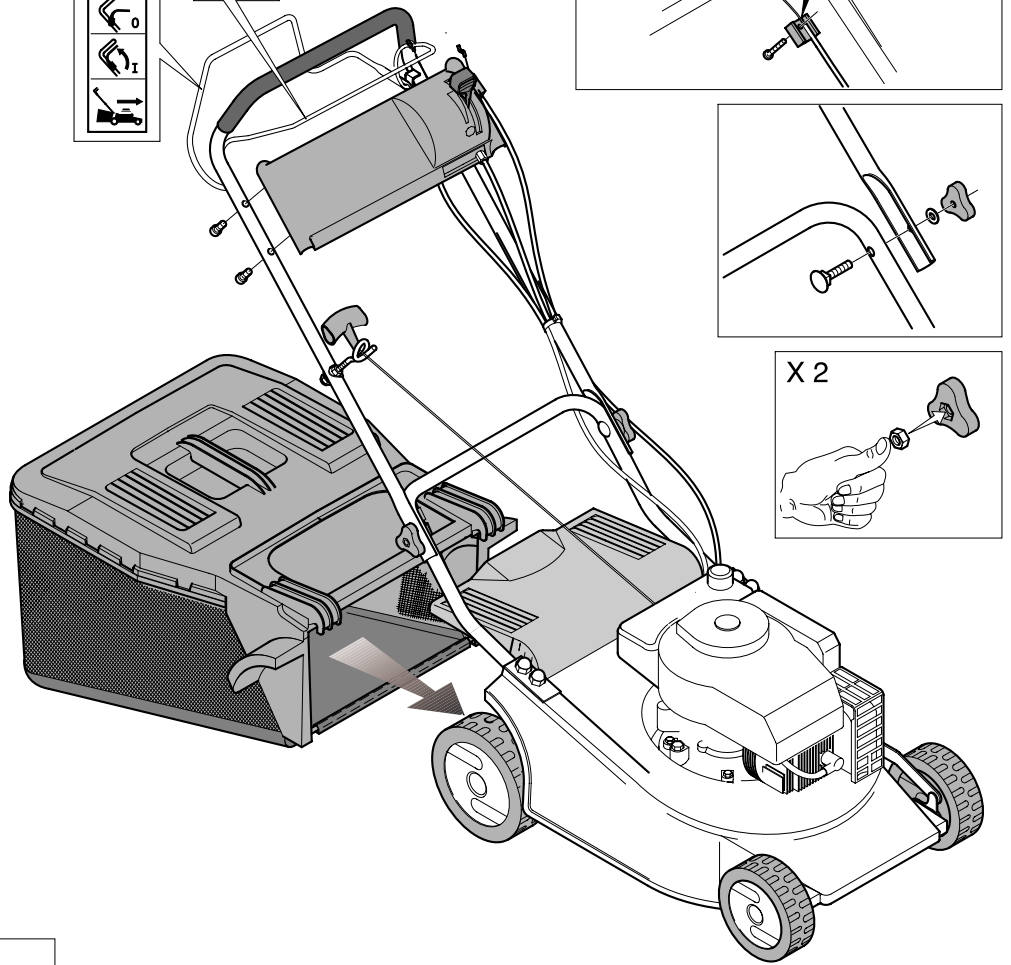
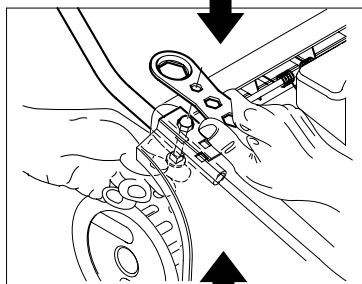
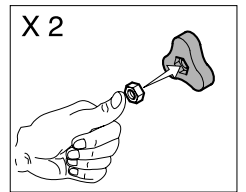
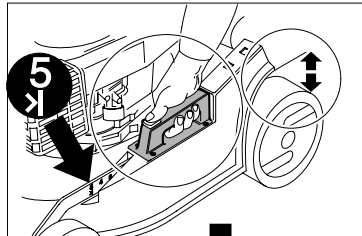
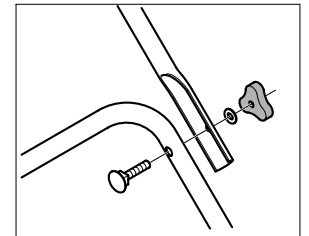
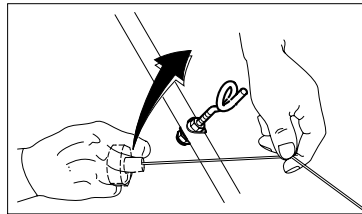
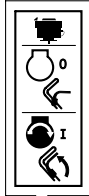
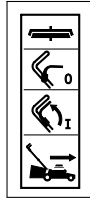
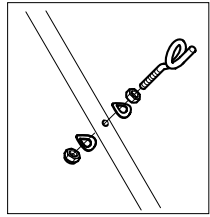
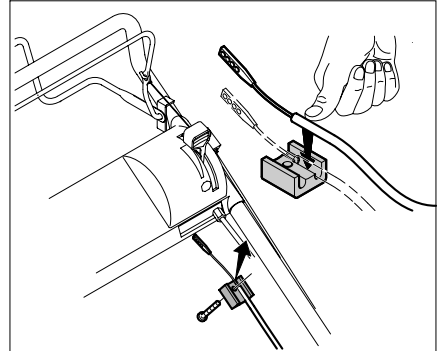
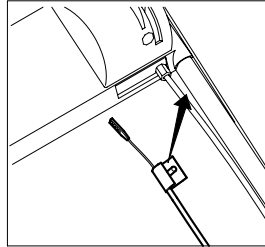
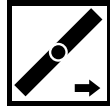
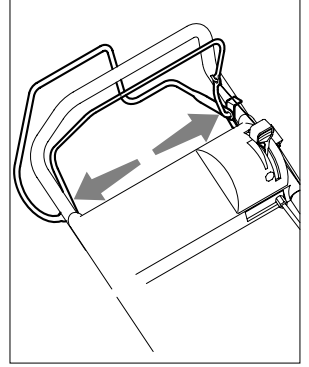
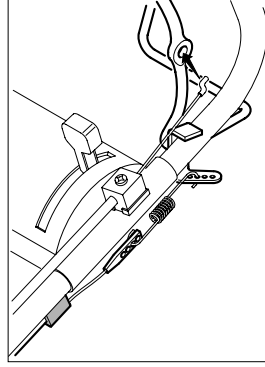
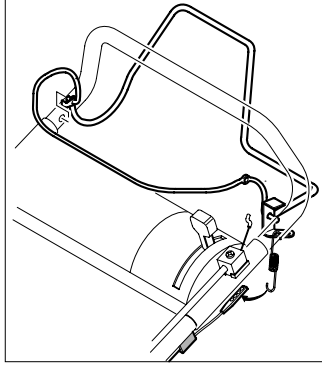
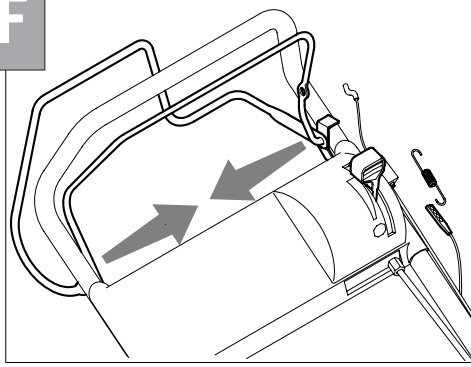

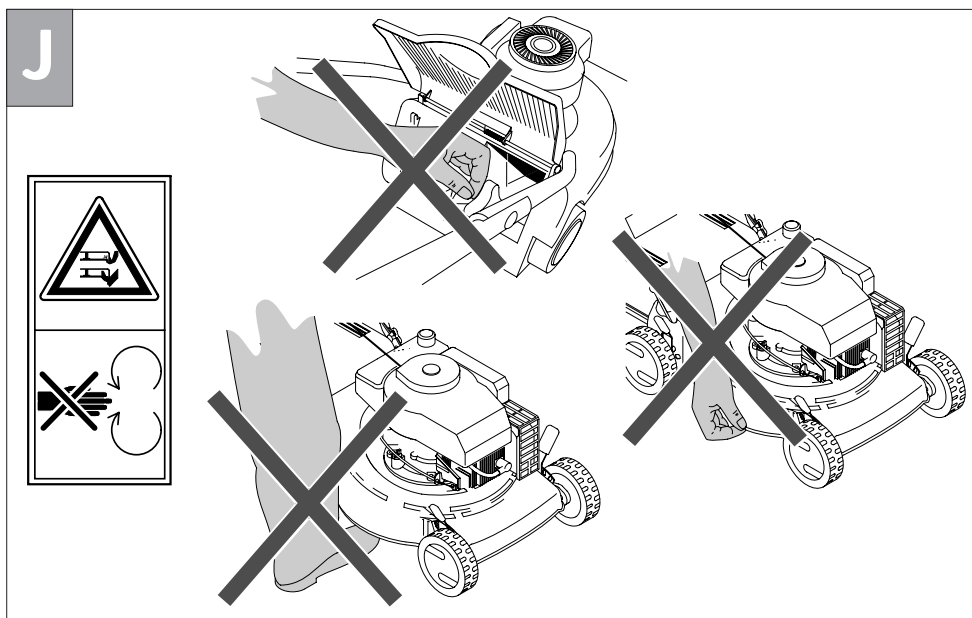
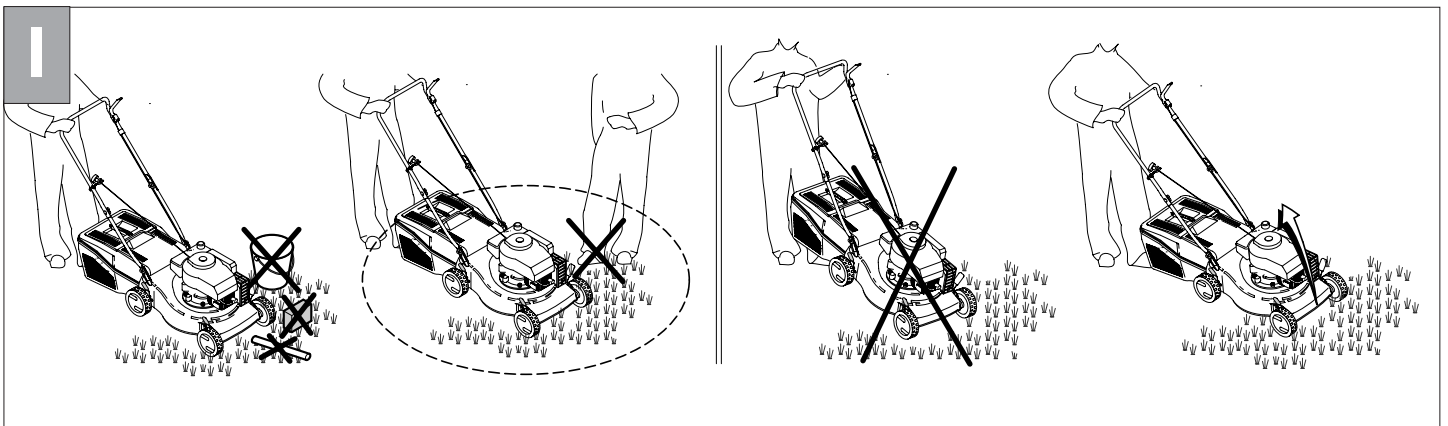
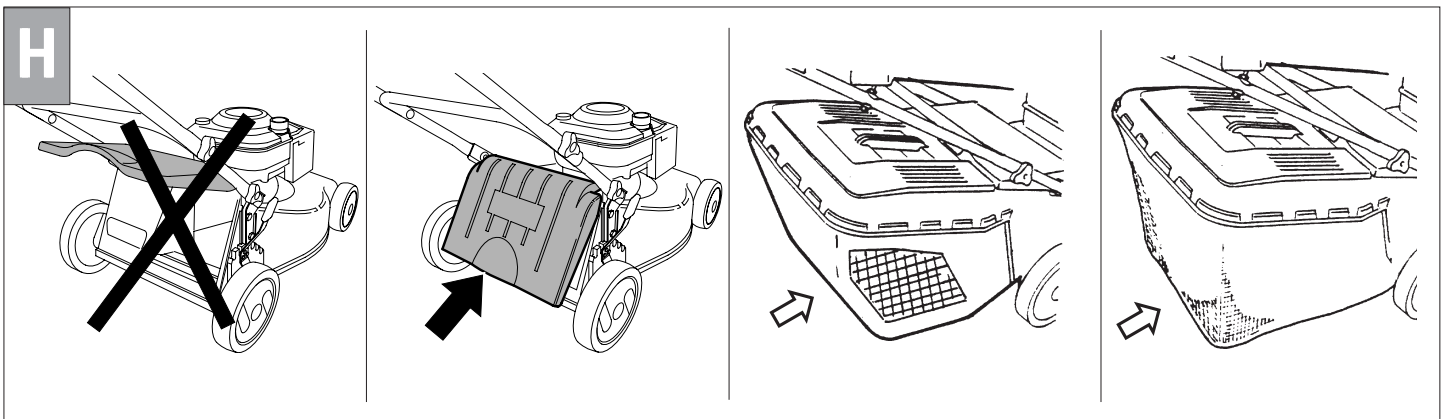
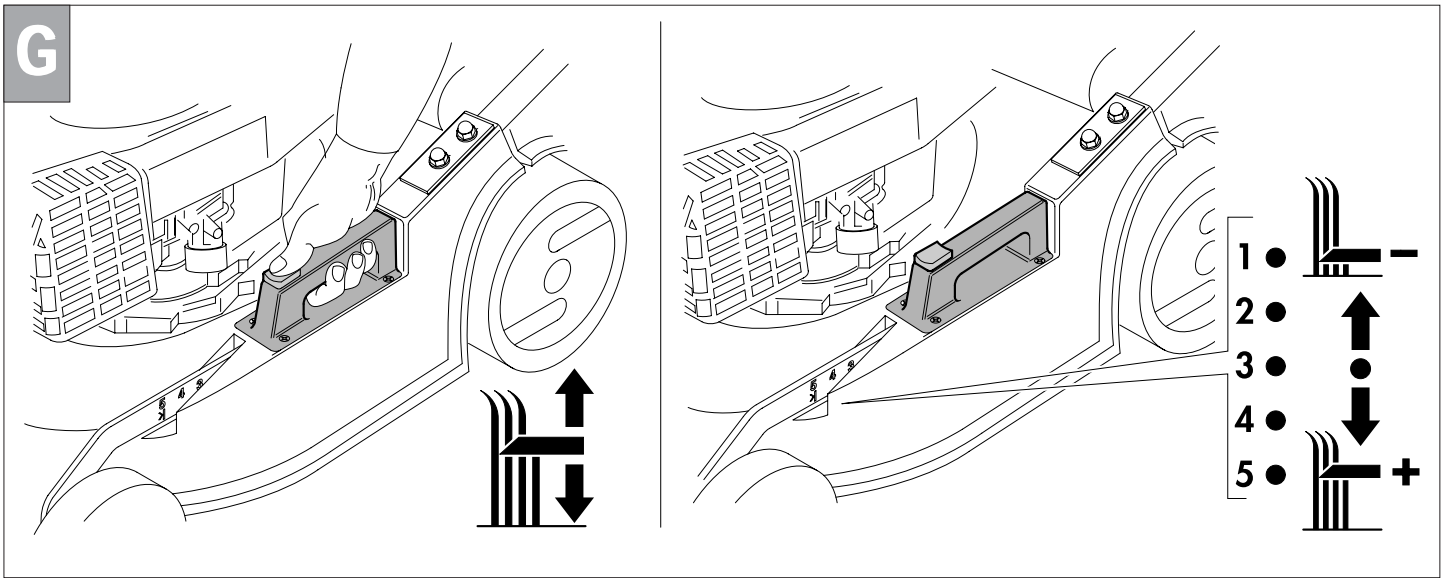

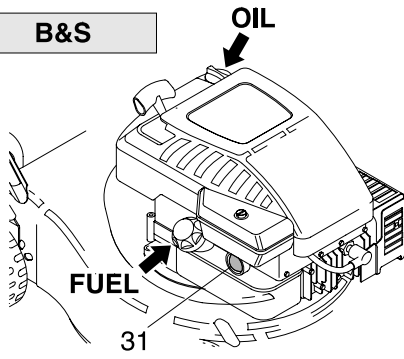
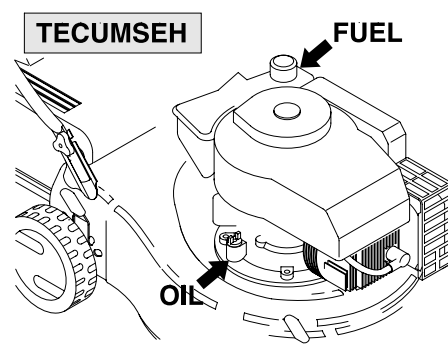
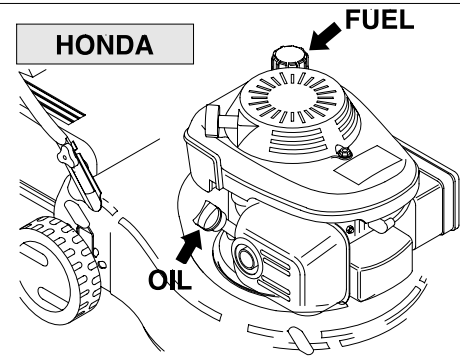
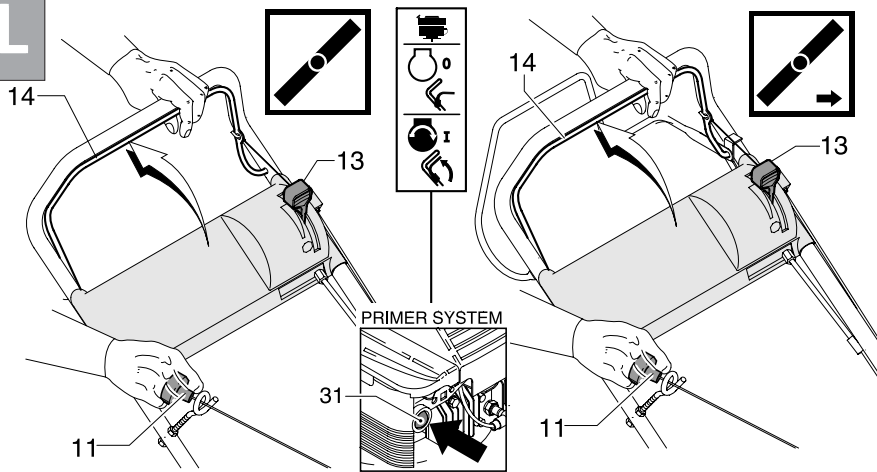
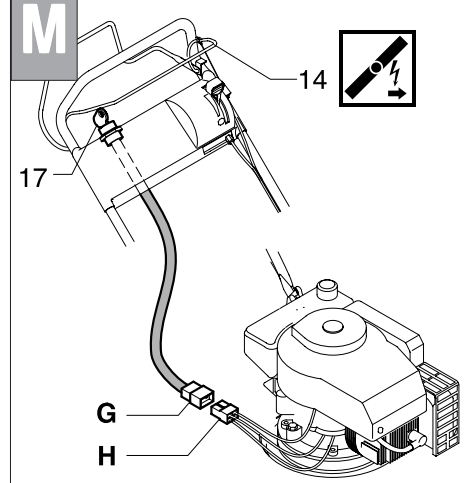
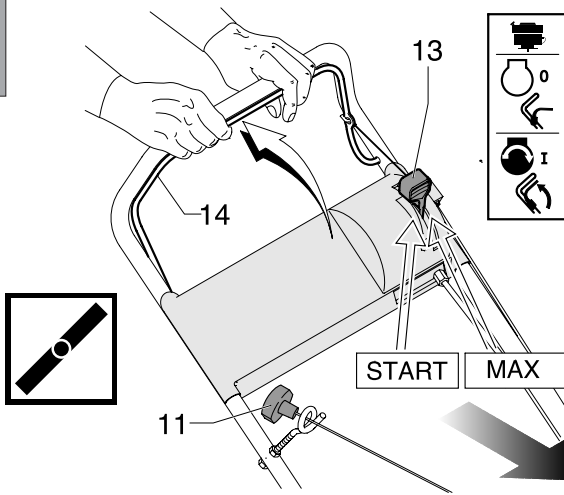
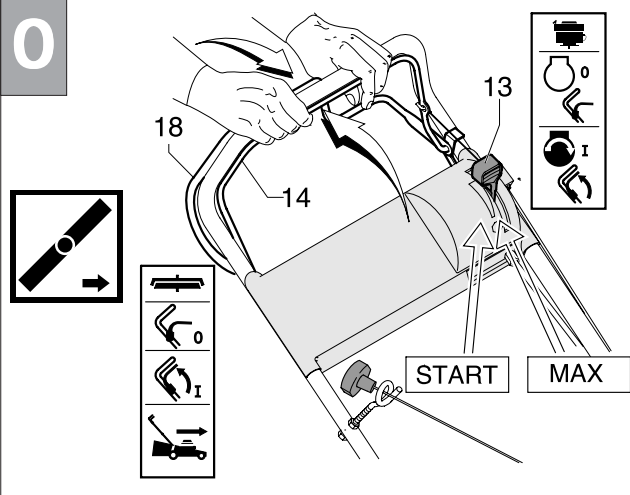
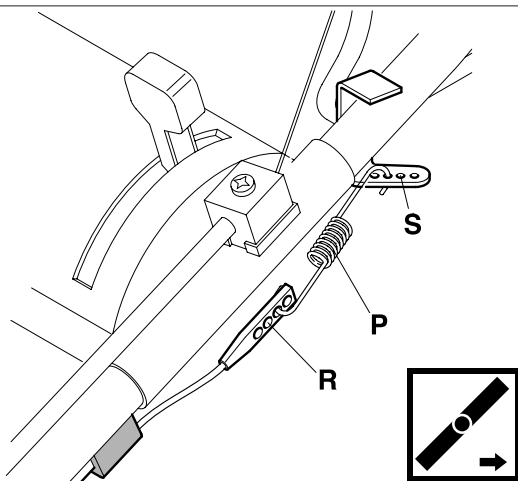

**K****B&S****TECUMSEH****HONDA****L****M****N****O****P****Q**