

GB EC Declaration of Conformity
The undersigned, authorised by E.O.P.I., declares that the following product: **52 quattro T**, manufactured by E.O.P.I., Valmadrera, Italia, are in accordance with the European Directives **98/37/EEC** (Machinery Directive), **93/68/CEE** (CE Marking Directive) & **89/336/CEE** (Directive on electromagnetic compatibility), directive **2000/14/CEE** (Annex V).

DE CE Konformitätserklärung
Der Unterzeichnete, bevollmächtigt durch E.O.P.I., erklärt, daß folgende Geräte: **52 quattro T**, hergestellt durch E.O.P.I., Valmadrera, Italia, den Europäischen Richtlinien **98/37/EEC** (Maschinenrichtlinie), **93/68/CEE** (CE Kennzeichnungsrichtlinie) & **89/336/CEE** (EMV Richtlinie) entsprechen, richtlinie **2000/14/CEE** (Anhang V).

FR Déclaration de conformité Européenne
Le soussigné, dûment mandaté par E.O.P.I., déclare que le produit suivant: **52 quattro T**, fabriqués par E.O.P.I., Valmadrera, Italia, est conforme aux Directives Européennes **98/37/EEC** (Directive Sécurité Machine), **93/68/CEE** (Directive Marquage CE) & **89/336/CEE** (Directive EMC), directive **2000/14/CEE** (Annexe V).

NL EG Conformiteitsverklaring
Ondergetekende, gemachtigd door E.O.P.I., verklaart dat de volgende producten: **52 quattro T**, geproduceerd door E.O.P.I., Valmadrera, Italia voldoen aan de Europese Richtlijnen **98/37/EEC** (Machinery Richtlijn), **93/68/CEE** (EG Markering Richtlijn) & **89/336/CEE** (Richtlijn aangaande elektromagnetische compatibiliteit), richtlijn **2000/14/CEE** (Annex V).

NO EF Erklæring om Overensstemmelse
Undertegnede, autorisert av E.O.P.I., erklærer at følgende produkt **52 quattro T**, konstruert av E.O.P.I. 23868 Valmadrera (Lecco) Via Como, 72 Italia, er i overensstemmelse med følgende europeiske direktiver: **98/37/CEE** (Maskineridirektiv), **93/68/CEE** (CE-merkingdirektiv) & **89/336/CEE** (Direktiv om elektromagnetisk kompatibilitet), direktiv **2000/14/CEE** (Annex V).

FI EY Julistus Vastaavuudesta
Allekirjoittanut, E.O.P.I. in valtuuttamana, vakuuttaa että seuraavat tuotteet: **52 quattro T**, ja jotka on valmistanut E.O.P.I., Valmadrera, Italia, ovat Euroopan direktiivien **98/37/EEC** (Koneisto-direktiivi), **93/68/CEE** (CE Merkintä-direktiivi) & **89/336/CEE** (Elektromagneettinen Yhteensopivuus-direktiivi) mukainen, direktiivi **2000/14/CEE** (Liite V).

SE EG-försäkran om överensstämmelse
Undertecknad, auktoriserad av E.O.P.I., försäkrar att följande produkter: **52 quattro T**, tillverkade av E.O.P.I., Valmadrera, Italia, är i överensstämmelse med följande europeiska direktiv **98/37/EEC** (Maskindirektiv), **93/68/CEE** (CE-märknings-direktiv) & **89/336/CEE** (Elektromagnetisk kompatibilitet), direktiv **2000/14/CEE** (Annex V).

DK EU Overensstemmelseerklæring
Undertegnede, bemyndiget af E.O.P.I., erklærer herved, at følgende produkter: **52 quattro T**, E.O.P.I., Valmadrera, Italia, er i overensstemmelse med de europæiske direktiver **98/37/EEC** (Maskineri direktiv), **93/68/CEE** (CE mærkningsdirektiv) & **89/336/CEE** (EMC-direktiv), direktiv **2000/14/CEE** (Annex V).

ES Declaracion de cumplimiento de la directriz de la UE
El abajo firmante, autorizado por E.O.P.I., afirma que los siguientes productos: **52 quattro T**, fabricados por E.O.P.I., Valmadrera, Italia, cumplen con las directivas Europeas **98/37/EEC** (Directiva sobre Maquinaria), **93/68/CEE** (Directiva sobre Marcas de la CE) & **89/336/CEE** (Directiva sobre 'Compatibilidad Electro Magnética'), directiva **2000/14/CEE** (Anexo V).

PT Declaração de Conformidade
O abaixo assinado, autorizado por E.O.P.I., declara que os seguintes produtos: **52 quattro T**, fabricada por E.O.P.I., Valmadrera, Italia, estão de acordo com as Directivas Europeias **98/37/EEC** Directiva de Maquinaria), **93/68/CEE** (Directiva de Marcação CE) e **89/336/CEE** (Directiva de Compatibilidade Electromagnética), directiva **2000/14/CEE** (Apêndice V).

IT Dichiarazione di Conformità CE
Il sottoscritto, autorizzato dalla E.O.P.I., dichiara che il seguente prodotto: **52 quattro T**, costruito da E.O.P.I., Valmadrera, Italia, è conforme alle Direttive Europee: **98/37/EEC** (Direttiva Macchine), **93/68/CEE** (Direttiva Marcatura CEE) & **89/336/CEE** (Direttiva Compatibilità Elettromagnetica), direttiva **2000/14/CEE** (Allegato V).

HU Technikai leírások
Alulírott, rendelkezőve a E.O.P.I. engedélyével, kijelenti, hogy a jelen termék **52 quattro T**, melyet a E.O.P.I. 23868 Valmadrera (Lecco) Via Como, 72 Italia, gyártott, megfelel az európai szabványoknak: **98/37/CEE** (gépekre vonatkozó), **93/68/CEE** (márkázásnak) és **89/336/CEE** (elektromágneses összességzetetehetőségnek) megfelelnek, direktiva **2000/14/CEE** (Melléklet V).

GR Δήλωση Συμμόρφωσης προς τις Εντολές της ΕΕ
Ο υπογεγραμμένος, με εξουσιοδότηση της E.O.P.I., δηλώνει ότι τα εξής προϊόντα: **52 quattro T**, κατασκευασθέντα από την E.O.P.I., Valmadrera, Italia, ΗΠΑ ανταποκρίνονται προς τις Ευρωπαϊκές Εντολές **98/37/CEE** (η περί Μηχανημάτων Εντολή), **93/68/CEE** (η περί του Σήματος CE Εντολή) & **89/336/CEE** (η περί Ηλεκτρομαγνητικής Συμβατότητας Εντολή), Αρκετήρια **2000/14/CEE** (Πηρο ετηε V).

Todero Ceilin
Valmadrera, 15.12.01
Pino Todero (Direttore Tecnico)
E.O.P.I.

Electrolux Outdoor Products
Via Como 72
23868 Valmadrera (Lecco)
ITALIA
Phone +39 0341 203111 - Fax +39 0341 581671

Our policy of continuous improvement means that the specification of products may be altered from time to time without prior notice. Electrolux Outdoor Products manufacture products for a number of well known brands under various registered patents, designs and trademarks in several countries.
© Electrolux Outdoor Products Italy

The Electrolux Group. The world's No.1 choice.

The Electrolux Group is the world's largest producer of powered appliances for kitchen, cleaning and outdoor use. More than 55 million Electrolux Group products (such as refrigerators, cookers, washing machines, vacuum cleaners, chain saws and lawn mowers) are sold each year to a value of approx. USD 14 billion in more than 150 countries around the world.

PN 249339 REV. 01 (12/03)



52 QUATTRO PM B 522 M

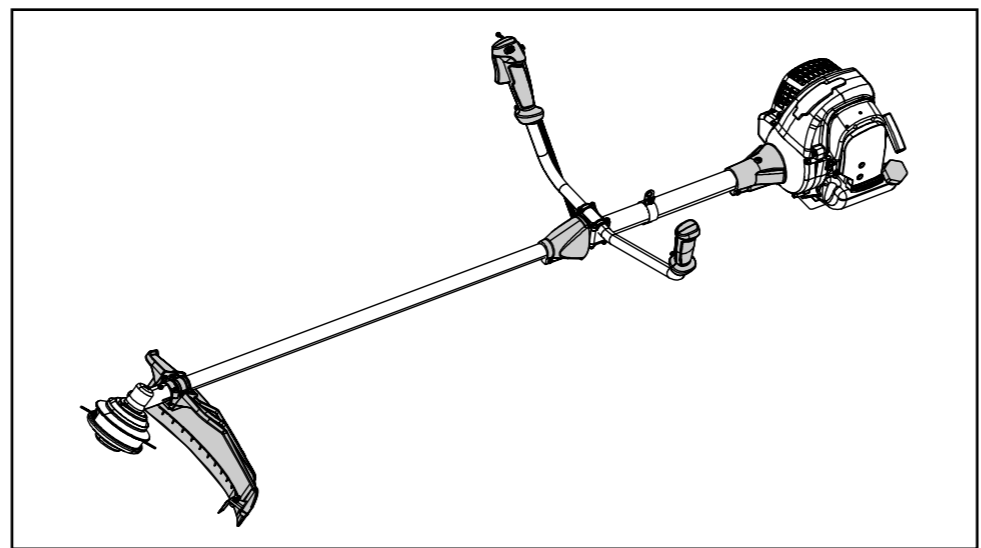

GB
DE
FR
NL
NO
PT
IT
HU
GR

INSTRUCTION MANUAL
IMPORTANT INFORMATION: Please read these instructions carefully and make sure you understand them before using this unit. Retain these instructions for future reference.

BETRIEBSANWEISUNG
WICHTIGE INFORMATION: Lesen Sie diese Hinweise zur Handhabung des Geräts aufmerksam durch. Verwenden Sie es erst, wenn Sie sicher sind, daß Sie alle Anweisungen verstanden haben und gut aufbewahren.

MANUEL D'INSTRUCTIONS
RENSEIGNEMENTS IMPORTANTS: Avant d'utiliser cet appareil, veuillez lire attentivement les instructions et assurez-vous de les avoir comprises. Conservez les instructions pour référence ultérieure.

HANDLEIDING
BELANGRIJKE IMPORTANTS: Lees deze handleiding aandachtig en zorg dat u alles begrijpt alvorens de kettingzaag te gebruiken en bewaar ze voor toekomstige raadpleging.

BRUKERHÅNDBOK
VIKTIG INFORMASJON: Les disse anvisningene nøye og forsikre deg om at du forstår dem for du bruker enheten og oppbevar dem for senere bruk.

OHJEKIRJA
TÄRKEÄÄ TIETOA: Lue nämä ohjeet huolellisesti ja varmista, että olet ymmärtänyt ne, ennen kuin alat käyttää tätä laitetta ja säilytä myöhempää tarvetta varten.

BRUKSANVISNING
VIKTIG INFORMATION: Läs instruktionerna noggrant och försäkra dig om att du förstår dem innan du använder utrustningen och spara dem för framtida behov.

DK
ES
PT
IT
HU
GR

BRUGERHÅNDBOG
VIGTIGE OPLYSNINGER: Læs instruktionerne omhyggeligt, før du bruger enheden og gemme til senere henvisning.

MANUAL DE INSTRUCCIONES
INFORMACIÓN IMPORTANTE: Lea atentamente las instrucciones y asegúrese de entenderlas antes de utilizar esta aparato. Conserve las instrucciones para la referencia en el futuro.

MANUAL DO OPERADOR
INFORMAÇÕES IMPORTANTES: Queira ler cuidadosamente estas instruções e tenha certeza de entendê-las antes de usar a serra e guarde para consulta futura.



LIBRETTO D'ISTRUZIONI
INFORMAZIONI IMPORTANTI: Leggere le istruzioni attentamente e capirle bene prima di usare l'utensile. Conservare per ulteriore consultazione.

HASZNÁLATI ÚTMUTATÓ
Jótállást vállalni csak rendeltetésszerűen használatba vett gépekre tudunk. Kérj ü hogy a gép használatba vétele előtt gondosan olvassa el a kezelési utasításokat.

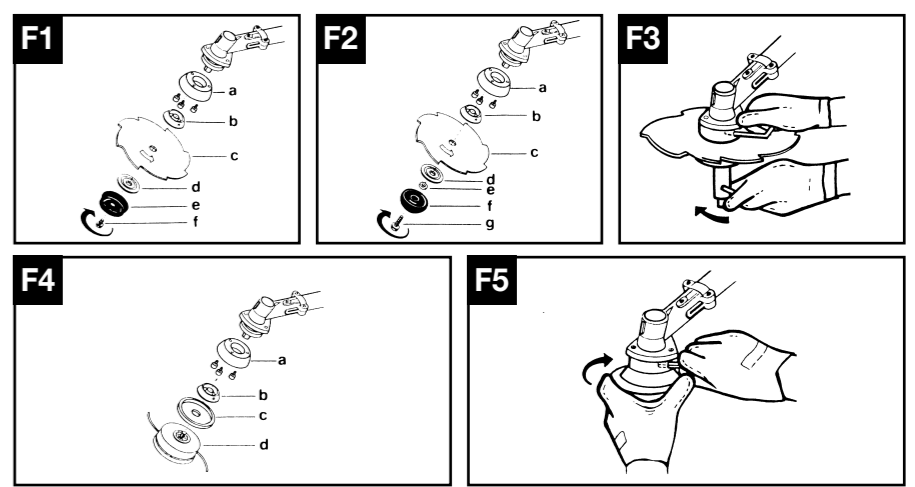
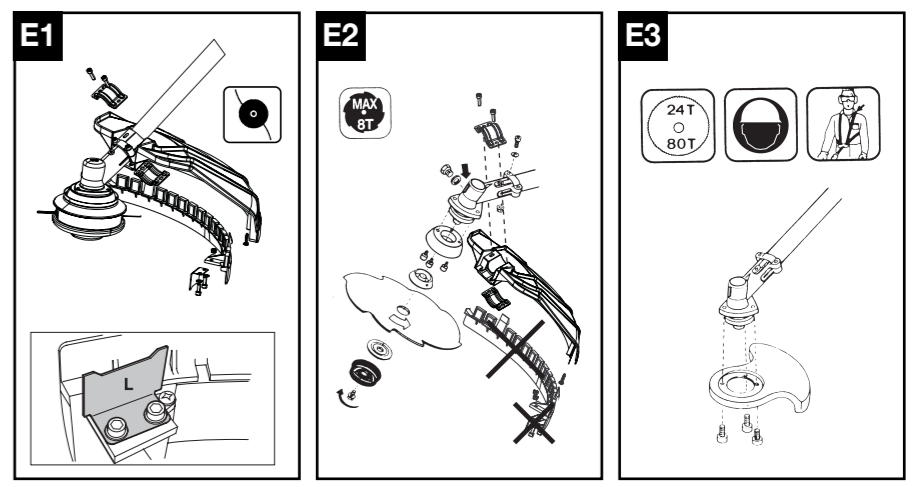
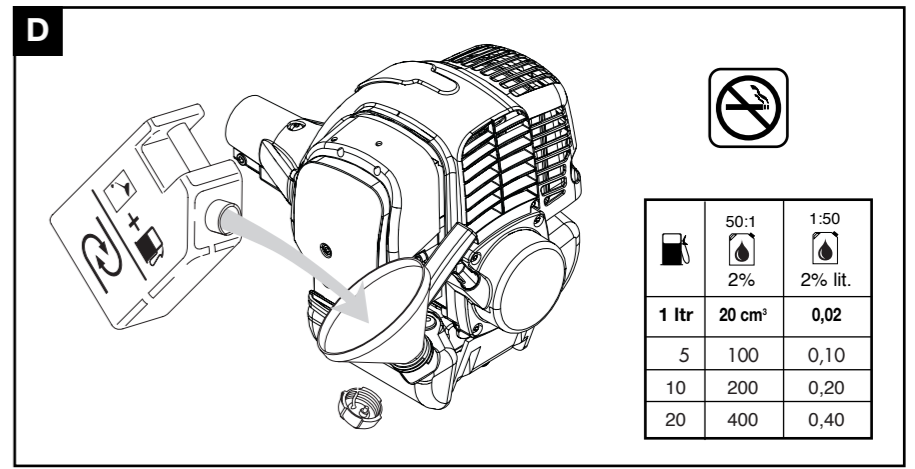
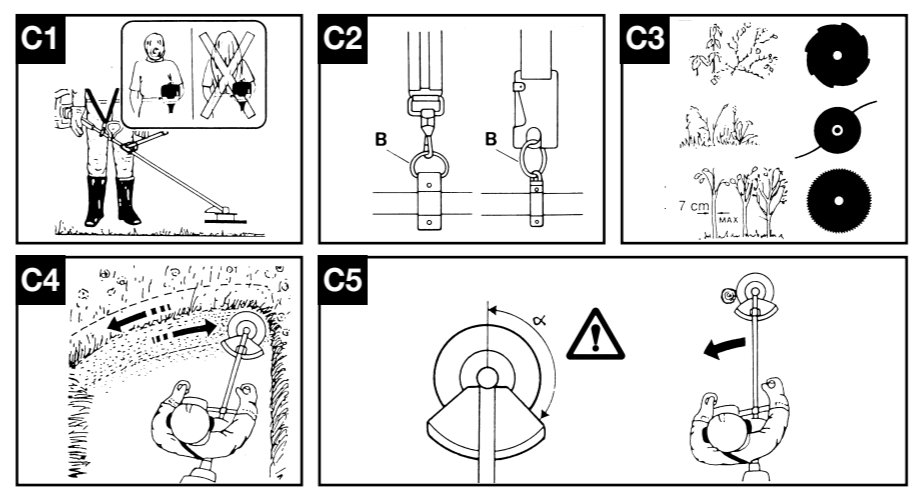
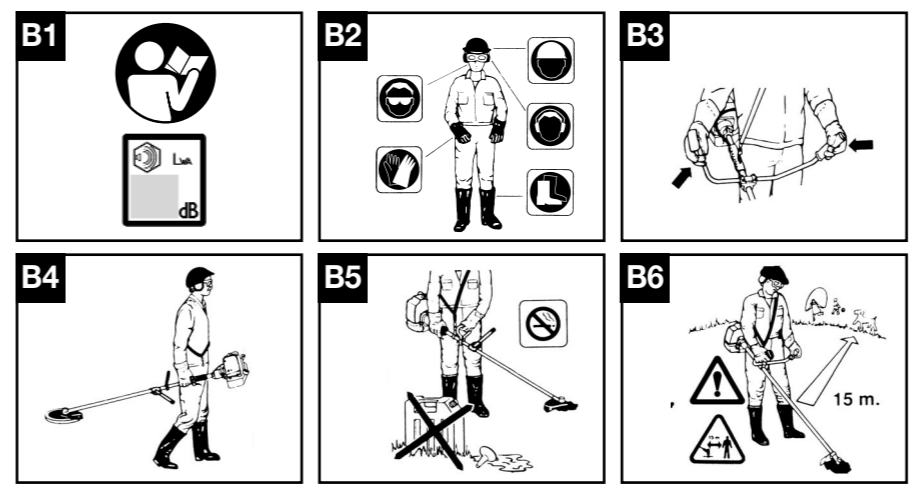
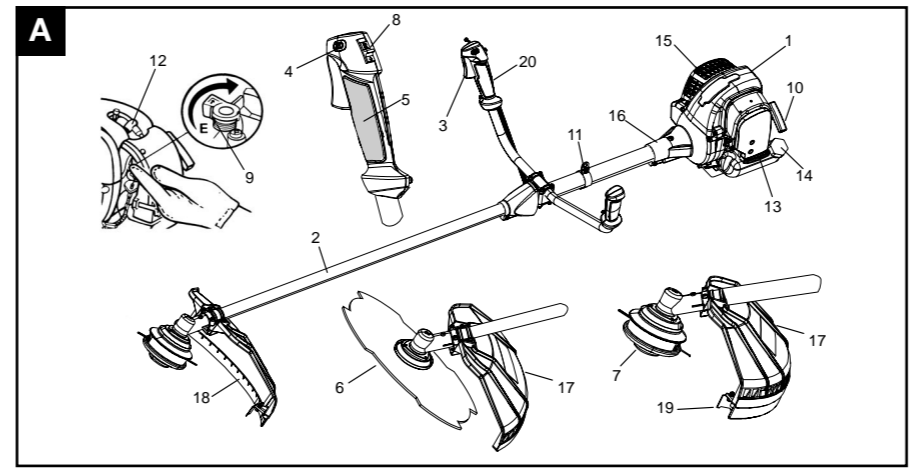
ΕΓΧΕΙΡΙΔΙΟ ΧΕΙΡΙΣΜΟΣ
ΣΗΜΑΝΤΙΚΕΣ ΠΛΗΡΟΦΟΡΙΕΣ: Διαβάστε προσεκτικά αυτές τις οδηγίες και Φροντίστε να τις χατανοήσετε αυτό το μηχανήμα και Φυλάξτε το για να το συμβουλευέστε στο μέλλον.

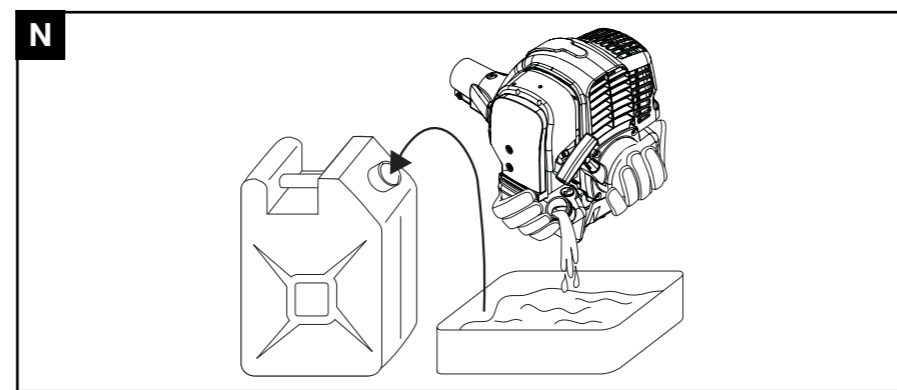
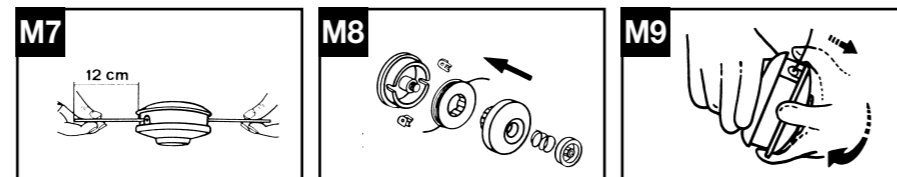
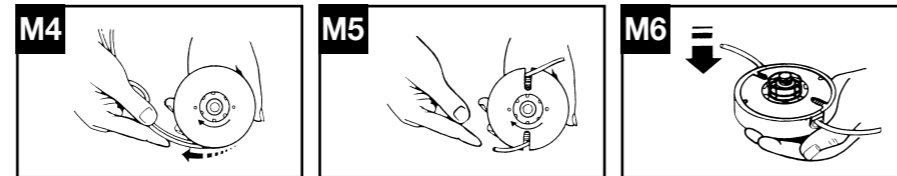
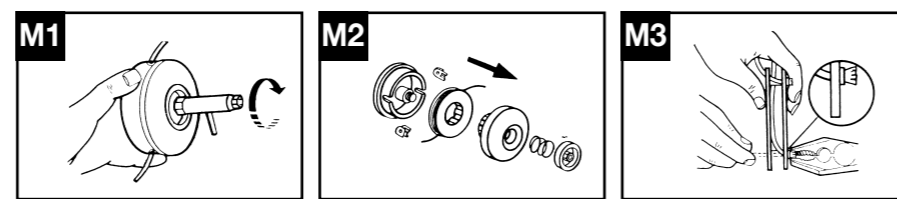
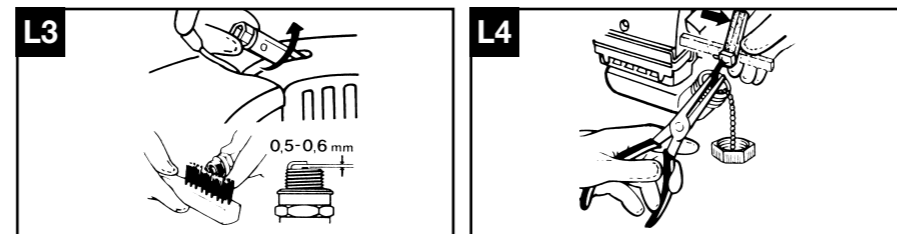
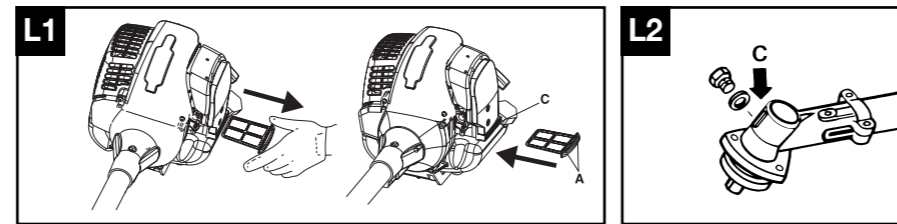
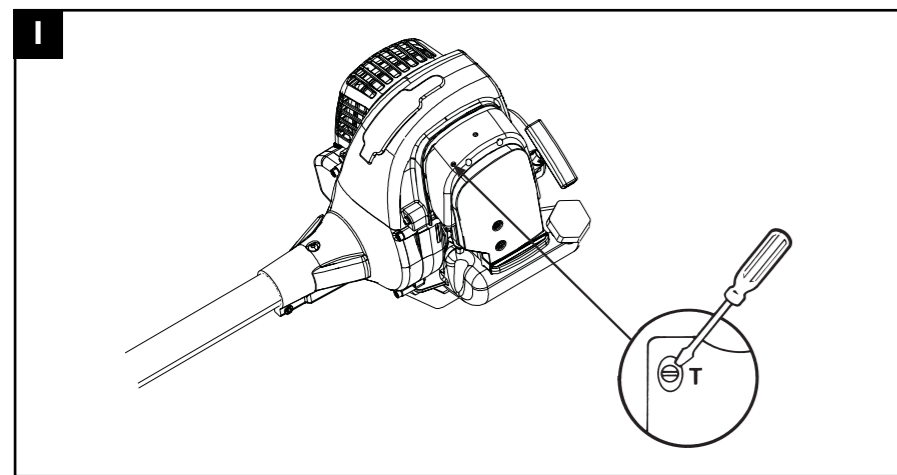
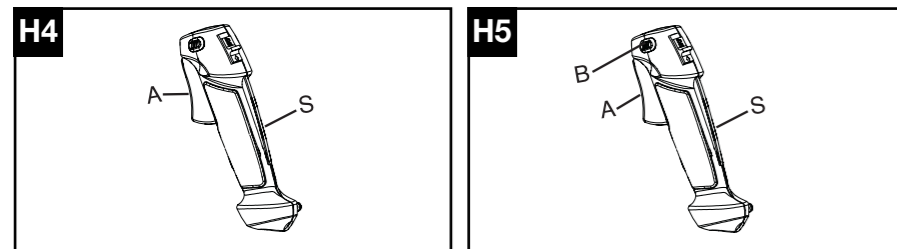
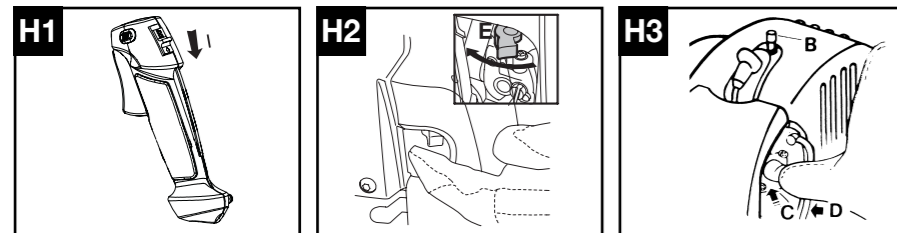
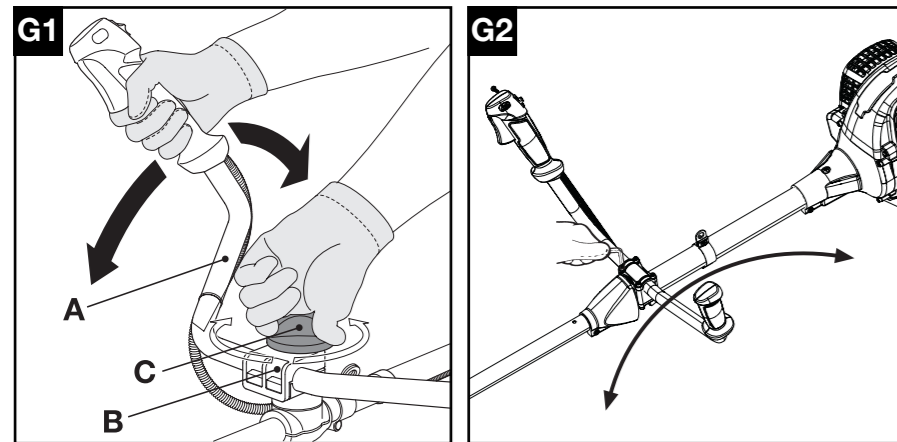



		52 cc	
1,18" 3 mm	197" 5000mm	538242506	248960
4T	9" 230 mm	226134B	248960
4T	10" 255 mm	226135B	248960
8T	9" 230mm	236711B	248960
8T	10" 255mm	236713B	248960
24T	9" 230mm	240998B	240936B
		240553	236677
80T	9" 230mm	240953B	240936B
		240553	236677

- GB** SUMMARY CHART TO IDENTIFY THE CORRECT GUARD NEEDED, WITH DIFFERENT CUTTING ATTACHMENTS
- DE** ÜBERSICHTSTABELLE ZUR AUSWAHL DES RICHTIGEN SCHUTZBLECHES FÜR DIE EINZELNEN SCHNEIDWERKZEUGE
- FR** TABLEAU RECAPITULATIF POUR LE CORRECT ACCOUPLEMENT LAME OU TETE FIL NYLON / DEFENSE DE SECURITE
- NL** OVERZICHTSTABEL OM TE BEPALEN WELKE BESCHERMKAP GEBRUIKT MOET WORDEN BIJ DE DIVERSE MAAI-ONDERDELEN
- NO** TABELL FOR KORREKT MONTERING AV TRÅDSPOLE/SAGBLAD OG SPRUTSKJÆRM/SIKKERHETSVÆRN
- FI** TAULOKKO LEIKKAAVAN PÄÄN/TURVASUOJUKSEN OIKEASTA YHDISTELMÄSTÄ
- SE** SAMMANFATTANDE TABELL ÖVER KORREKT KOMBINATION AV SKÄRHUVUD/SÄKERHETSSKYDD
- DK** OVERSIGTSTABEL VEDRØRENDE DEN KORREKTE SAMMENSÆTNING AF KNIV OG BESKYTTELSESSKÆRM
- ES** TABLA PARA EL CORRECTO ACOPLAMIENTO DE LA CABEZA CORTANTE Y PROTECTOR DE SEGURIDAD
- PT** TABELA DE RESUMO PARA A CORRETA APLICAÇÃO DA CABEÇA CORTANTE E DEFESA DE SEGURANÇA
- IT** TABELLA RIASSUNTIVA PER IL CORRETTO ABBINAMENTO TESTA TAGLIENTE / DIFESA DI SICUREZZA
- HU** ÖSSZEFOGLALÓ TÁBLÁZAT: A NYÍRÓFEJ ÖSSZEÁLLÍTÁSA / BALESETVÉDELEM
- GR** ΠΕΡΙΛΗΠΤΙΚΟΣ ΠΙΝΑΚΑΣ ΓΙΑ ΤΗΝ ΕΠΙΣΗΜΑΝΣΗ ΤΟΥ ΚΑΤΑΛΛΗΛΟΥ ΠΡΟΦΥΛΑΚΤΗΡΑ, ΜΕ ΔΙΑΦΟΡΑ ΚΟΠΤΙΚΑ ΕΞΑΡΤΗΜΑΤΑ

- GB** Due to a constant product improvement programme, the factory reserves the right to modify technical details mentioned in this manual without prior notice.
- DE** Im Sinne des Fortschritts behält sich der Hersteller das Recht vor, technische Änderungen ohne vorherigen Hinweis durchzuführen.
- FR** La Maison se réserve la possibilité de changer des caractéristiques et des données de ce manuel à n'importe quel moment et sans préavis.
- NL** Door konstante produkt ontwikkeling behoudt de fabrikant zich het recht voor om technische specificaties zoals vermeld in deze handleiding te veranderen zonder hiervan vooraf bericht te geven.
- NO** Produsenten forbeholder seg all rett og mulighet til å forandre tekniske detaljer i denne manualen uten forhåndsvarsel.
- FI** Jatkuvan tuotteen parannusohjelman tähden valmistaja pidättää oikeuden vaihtaa ilman ennakkovaroitusta tässä ohjekirjasessa mainittuja teknisiä yksityiskohtia.
- SE** Tilverkaren reserverar sig rätten att ändra fakta och uppgifter ur handboken utan förvarning.
- DK** Producenten forbeholder sig ret til ændringer, hvad angår karakteristika og data i nærværende instruktion, når som helst og uden varsel.
- ES** La firma productora se reserva la posibilidad de cambiar las características y datos del presente manual en cualquier momento y sin previo aviso.
- PT** A casa productora se reserva a possibilidade de variar características e dados do presente manual em qualquer momento e sem aviso prévio.
- IT** La casa produttrice si riserva la possibilità di variare caratteristiche e dati del presente manuale in qualunque momento e senza preavviso.
- HU** A gyártó cég fenntartja a jogot arra, hogy a használati utasításban megadott adatokon és technikai tulajdonságokon bármikor és előzetes bejelentés nélkül változtasson.
- GR** Λόγω προγράμματος συνεχούς βελτίωσης προϊόντων, το εργοστάσιο επιφυλάσσεται του δικαιώματος να τροποποιεί τις τεχνικές λεπτομέρειες που αναφέρονται στο εγχειρίδιο αυτό χωρίς προηγούμενη ειδοποίηση.

A. General description

- | | |
|--|---|
| <ol style="list-style-type: none"> 1) ENGINE 2) SHAFT 3) THROTTLE TRIGGER 4) THROTTLE ADVANCE 5) RIGHT CONTROL HANDLE 6) BLADE 7) NYLON STRING HEAD 8) STOP SWITCH 9) CHOKE LEVER 10) STARTER HANDLE | <ol style="list-style-type: none"> 11) HARNESS RING 12) SPARK PLUG 13) AIR FILTER 14) FUEL TANK CAP 15) MUFFLER SHIELD 16) ENGINE SHAFT JOINT 17) SAFETY GUARD 18) STRING HEAD SAFETY GUARD 19) LINE CUTTER BLADE 20) SAFETY GRIP |
|--|---|

Safety precautions



If not used properly this Petrol Brushcutter can be dangerous. The warnings and safety instructions must be followed to ensure reasonable safety and efficiency in using this product. The operator is responsible for following the warnings and instructions in this manual and on the product.

Explanation of Symbols



Warning



Read the user instructions carefully to make sure you understand all the controls and what they do.



Wear safety clothing:
Approved safety glasses or face shield



Wear safety clothing:
Approved safety helmet



Wear safety clothing:
Approved ear defender



Wear safety clothing:
Approved gloves



Wear safety clothing:
Approved safety footwear



Do not smoke while refuelling or while operating the trimmer



Do not use metal blades



Maximum blade speed



Blade thrust



Beware of projected objects



Maximum safety distance

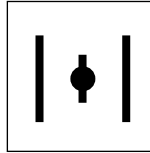

Choke fully opened
(hot start / run)

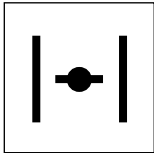

Choke closed (cold start)

B. Safety precautions

- 1) Make sure all operators study this manual carefully before using the trimmer; only use this machine for usage specifically mentioned in this manual.

Never allow children to use the trimmer.

- 2) When working with the trimmer wear suitable clothes: a) Close fitting protective clothes (do not wear short trousers or loose clothes). b) Safety shoes (do not wear sandals and do not work bare-foot). c) Heavy-duty gloves. d) Safety face shield or goggles. Ensure you peel off the protective films, if existing, from the see-through plastic. e) Ear protection. f) Head protection when using circular saw blades. Make sure you know how to stop the engine in an emergency (see the section STARTING AND STOPPING ENGINE). Never use the trimmer when tired, physically indisposed or under the effect of alcohol, certain medicines or other drugs. Be careful of the rotating cutting attachment and hot surfaces on the unit.

- 3) Prolonged use of this product or other machines exposing the operator to vibration may produce Whitefinger's disease (Raynaud's Phenomenon). This may reduce the hands' ability to feel and regulate temperature and may produce general numbness. Continual or regular users should therefore monitor closely the condition of their hands or fingers. If any of the symptoms appear, seek immediate medical advice. Always hold the trimmer firmly with both hands. When working maintain a firm foothold. The trimmer must be used exclusively as recommended (see section SAFETY USAGE).

- 4) Do not carry the trimmer while the engine is running even for short distances; switch off the engine and carry the unit with the cutting head behind you. When carrying the trimmer in a

vehicle, secure it to avoid fuel leakage. Always empty the fuel tank before transporting the unit.

ATTENTION: For your safety the blade must be kept at all times in its proper case during transport and storage.

Start the trimmer on a flat surface. When starting the unit, ensure you have a firm footing. Make sure the blade or the nylon string head does not touch the ground or any obstacle.

- 5) PRECAUTIONS AGAINST FIRE: do not operate the trimmer near fire or spilled petrol. Do not run the engine in closed or poorly ventilated areas. EXHAUST GASES ARE POISONOUS WHEN INHALED, THEY CAN CAUSE SUFFOCATION AND DEATH.

After refuelling always wipe off any spilled fuel. Do not smoke during this operation. Start the engine far away from the refuelling area and from fuel containers (minimum distance 3 meters). Do not refuel while the engine is still running.

- 6) Keep people and animals away from working area (minimum distance 15 meters). If somebody should approach you, turn the engine off and stop the blade or the rotating head (see chapter STARTING AND STOPPING THE ENGINE) as during operation the blade or the nylon string head might project grass, grit, or other debris. The blade is sharp, be careful even if handling it when the engine is off.

Wear heavy-duty gloves. Turn the engine off and wait for rotating parts to stop completely before working on the machine or before touching the blade or the string head above all to remove possible entangled material.

DO NOT USE THE MACHINE AT ALL IF THE SPECIFIED SAFETY GUARD IS NOT FIRMLY

ATTACHED (see sections SAFETY USAGE and BLADES AND NYLON STRING HEAD ASSEMBLY).

Pay careful attention to safety recommendations as you might put your life or somebody else's in danger as a result of: a) possible contact with cutting or rotating parts. b) possibility

of projection of various objects.

WARNING: do not start engine if it is not attached to the shaft as the clutch might disintegrate. For units equipped with a clutch, be sure the cutting attachment stops turning when the engine idles.

C . Safety usage

This product must be held to the right of the operator's body.

This will ensure exhaust fumes are directed away from the operator and will not be obstructed by the operator's clothing. If you have not used a trimmer before, spend some time in becoming familiar with the controls and method of usage before operation.

Check the machine carefully before using it.

Make sure that there are no loosened screws, damaged parts or fuel leakages.

Replace damaged or excessively worn accessories (blades, string heads, guards).

Ensure all maintenance or repair work is carried out by an authorised service center.

N.B. In order to maintain performance and safety, be sure to use original spare parts and accessories.

Avoid using the trimmer over excessively long periods of time.

Excessive amounts of vibration can be harmful.

- 1) Remove from the working area grit, debris, ropes, metal parts or any other object which might get entangled around the rotating parts or be dangerously projected.

Use only the correct accessory recommended for the type of vegetation to be cut. Do not let the rotating blade contact any foreign object such as stones, rocks, cans etc.

Secure hair to keep it above shoulder height. Before starting to work fit the harness. Adjust harness with the buckle so that the trimmer is well balanced on your right side and the blade or string head is parallel to the ground. Always maintain a firm foothold and a good balance while using the machine. Do not move backwards while you work as obstacles may not be visible.

The fitting of the safety pole barrier is obligatory on units equipped with a delta shaped handle when used with a metal blade.

The purpose of this safety pole barrier is to maintain a safe distance between the metal blade and the user under all normal or exceptional circumstances.

- 2) Harness ring (B) must never be moved from its original position to avoid unbalancing the unit.

Front handles can be separately adjusted to make usage easier on units fitted with "U" shaped handles.

- 3) The following accessories can be assembled to your trimmer: a) blade, b) nylon string head.

Do not attach any blade to a unit without proper installation of all required parts. Failure to use the proper parts can cause the blade to fly off and seriously injure the operator and/or bystanders.

a) WHEN USING A BLADE ENSURE THE CORRECT GUARD IS FITTED.

b) WHEN USING A NYLON STRING HEAD ENSURE THE CORRECT GUARD IS FITTED.

When using the unit always hold the front part of the machine (blade or nylon string head) below your waist.

NYLON STRING HEAD:

Always make sure it has been correctly assembled and fitted.

The nylon head is suitable to cut grass and weeds wherever there might be obstacles like trees, fences or walls.

The nylon string head also reduces the likelihood of damaging small plants and trees bark.

Only use flexible, nonfilament nylon line in the nylon line head as specified by the manufacturer. Never use metallic line which could break off and become a dangerous projectile.

BLADE:

Always make sure it has been correctly fitted.

When fitting or changing a cutting device, ensure you follow the instructions in the section "Blade or nylon string head assembly" with extreme precision. Fit these cutting devices using all and only the parts as described, and in the correct order.

- 4) BLADES: you can cut any type of grass, brushwood or shrub.

Operate the machine like a sickle always cutting at full throttle.

- 5) WARNING: always use a well sharpened blade.

A blade with worn teeth besides providing poor performance might also generate a sudden thrust. This can result in a violent sideways kick

caused when the blade touches against wood or solid bodies, such thrust might then cause the operator to lose control of the machine itself. Never attempt to work with a damaged blade but replace it with a new one.

THRUST: can occur when using any type of circular blade within the risk area: therefore it is advisable to cut using the remaining area of the blade.

CIRCULAR SAW BLADE: it can be used to cut sappling, small trees with a diameter up to 7 cm., to clean shrubs.

WARNING: IF A METAL 24-80 TOOTH BLADE (A SAW TOOTH BLADE) IS USED A DOUBLE

SHOULDER HARNESS AND A SAFETY GUARD (PROTECTION) MUST ALSO BE USED AS MARKED IN THE SUMMARY CHART (SEE CLOTHES SECTION IN SAFETY CHAPTER: ALWAYS WEAR A HELMET).

ALWAYS USE GENUINE ACCESSORIES AND SPARE PARTS AVAILABLE FROM AUTHORISED SERVICING DEALERS.

THE USE OF NON-ORIGINAL ACCESSORIES AND SPARE PARTS INCREASES THE RISK OF ACCIDENTS AND IN SUCH A CASE THE COMPANY IS NOT LIABLE FOR DAMAGE TO PEOPLE AND/OR THINGS.

D. Fuel mix

Warning! The brushcutter "four stroke 52 PM " is equipped with a special 4 stroke engine with waste lube , consequently it requires a totally sintetic 2 stroke engine oil or a McCulloch branded 2 stroke engine oil and unleaded petrol mix with a minimum octane rating of 90 (see chart).

WARNING! Do not use gasoline for any reasons, as the engine will be seriously damaged.

IMPORTANT

Always shake the fuel mix container thoroughly before pouring any fuel mix.

Fuel mix properties may deteriorate with time and should be used up within 2 months.

We recommend that you prepare fuel mix according to your immediate requirements only. Never use fuel mix more than 2 months old so as to avoid possible engine damage.

WARNING

Do not smoke when re-fuelling.

Always open the fuel cap slowly, to release any pressure build up in the tank.

Re-fuel in open spaces only, keeping away from naked flames or sparks.

SAFE STORAGE OF FUEL

Petrol fuel mix is highly inflammable. Put out all cigarettes, pipes and cigars before working with fuel. Avoid spilling fuel.

Store fuel in a cool, well ventilated place, in an approved container specifically designed for the purpose. Never store engine with fuel in the tank in enclosed, poorly ventilated areas, where fuel fumes may reach an open flame, spark or pilot light such as in a furnace, water heater, clothes dryer etc.

Petrol fumes can cause an explosion or a fire.

Never store large amounts of fuel.

To prevent possible restarting problems avoid running the fuel tank dry. This also helps to extend engine life.

E. Safety guard assembly

1) In the interest of safety, it is imperative that the unit is used with the correct guard when using any blade or a nylon string head, except the 24-80 tooth blade. Line cutter blade (L): assemble as illustrated.

2) When using a saw tooth blade (optional accessory), the correct guard must be fitted (P/N 240553).

A double shoulder harness must also be worn.

Only use blades or nylon string heads clearly marked with a maximum speed of at least 10,500 min⁻¹.

Follow the fitting instructions carefully.

N.B: Saw tooth blades (24 - 80 tooth) have a central base diameter of 20mm and therefore require the use of the appropriate size top flange to ensure a correct fit. The part number is detailed in the cutting attachment summary chart.

F. Blade and nylon string head assembly

Assemble the correct guard to suit the kind of blade or nylon string head to be used (See section: SAFETY GUARD ASSEMBLY).

- 1) Assemble blade as illustrated:
 - a) Flange guard - b) Upper cap with blade centering - c) Blade with text and directional arrow facing upwards - d) Lower washer - e) Fixed mower gauge - f) Blade locking screw (length mm 16).
- 2) If you want to assemble the rotating mower gauge, proceed as illustrated:
 - a) Flange guard - b) Upper cap with blade centering - c) Blade with text and directional arrow facing upwards - d) Lower washer - e) Spacer - f) Rotating mower gauge - g) Blade locking screw (length mm 34,5).

Replace the blade attachment bolt if damaged in any way.
- 3) Make sure that the blade bore opening fits perfectly around the centering collar on the upper cap.

Tighten counterclockwise.

While tightening, the blade assembly can be held fast by inserting the wrench or the screwdriver supplied into the cap and gearcase holes.

To do this, rotate the cap until the two holes coincide.

- 4) Assemble nylon string head as illustrated:
 - a) Flange guard - b) Upper cap - c) Guard d) Nylon string head

Tighten counterclockwise.

- 5) While tightening, the head assembly can be held fast by inserting the wrench or the screwdriver supplied into the holes as already shown for blade assembly.

WARNING: Do not use the guard for the nylon string head (18) when using a metal blade.

G. Handle assembly

1) DOUBLE HANDLE

Handle (A) can be adjusted for individual operator comfort by swivelling it forwards or backwards. To do this, loosen button (C), position the handle for maximum comfort, then tighten button (C) securely. Clip the suspension harness hook into one of the holes on the top side of the shaft support to achieve the best balance according to the type of work to be undertaken.

NB: Handle assembly (A) can be folded parallel to the shaft to facilitate transportation or storage. To do this, loosen knob (C), twist support (B) 90° in a clockwise direction, fold the handle (A) into the required position and then tighten knob (C).

2) DOUBLE HANDLE

Adjust and secure double hand clamp by tightening the screws.

H. Starting and stopping the engine

WARNING: First read sections: SAFETY RULES, SAFETY USAGE and SYMBOLS.

STARTING A COLD ENGINE

- 1) Position the on/off switch to the I (ON) position, away from the «STOP» position.
- 2) Rotate the choke lever in the direction illustrated by the arrows. This engages the fast idle system.
- 3) Squeeze the primer bulb (C) several times until you see fuel begin to return back through the tube (D) towards the fuel tank. Push the decompression valve (B) down if your model is fitted with one. Pull the starter handle until the engine starts.
- 4) Hold the machine safely and allow the engine to run for a few seconds. Grip the control han-

dle firmly, pushing down on the safety trigger (S) and then squeezing the accelerator trigger (A). This action automatically releases the spring loaded choke lever (E) disengaging the fast idle system.

WARNING: The fast idle system does cause the cutting attachment to rotate when engaged.

STARTING A WARM ENGINE

Position the on/off switch to the I (ON) position. Squeeze the primer bulb (C) several times until you see fuel begin to return back through tube (D) to the fuel tank. Pull the starter handle until the engine runs.

HOT ENGINE STARTING WITH

- 1) STOP switch on START position I. Trigger on

idle position (released). Choke towards (open position).

- 5) Depress the safety lever (**S**), squeeze the accelerator trigger (**A**) and push the throttle advance forwards (**B**). Now release the accelerator trigger (**A**) and then the throttle advance (**B**).
- 3) Press the primer bulb (**C**) several times until you see fuel going back to carburetor through pipe (**D**). Pull starter rope.

WARNING: when the throttle (B) advance is engaged, the head or blade rotates.

5) ENGINE STOPPING

Press the stop switch moving it to STOP position 0.

WARNING: when the engine is switched off rotating parts, blade or nylon string head, will keep on rotating for a few seconds. Hold the machine until all parts come to a standstill.

N.B. In an emergency the above mentioned delay in stopping may be shortened by touching blade parallel on the ground.

I. Carburettor adjustment

To adjust the idle speed, however, proceed as follows:

With engine running and warm, slowly turn screw 'T' clockwise until the engine runs smoothly with a consistent noise level but without making the cutting head rotate.

If the cutting attachment does move or the engine runs too fast, slowly turn screw 'T' in an anticlockwise direction until the correct speed is obtained.

Precise numerical engine speed settings are mentioned in the technical detail chart in the front of the owner's manual.

L. Regular maintenance

From time to time ensure all screws are tight. Replace damaged, worn, cracked or warped blades. Always make sure nylon string head or blade have been assembled correctly (see sections NYLON STRING HEAD and BLADE ASSEMBLY) and blade fastener is tightened.

1) AIR FILTER CLEANING

(at least every 25 working hours).

A dust clogged air filter may cause carburetor problems.

This may prevent the engine from reaching its maximum speed and cause high fuel consumption and/or difficult starting.

Remove filter cover as shown in figure 1.

Carefully clean the inside of filter box. The filter can also be cleaned with compressed air.

N.B. Slide the air filter back into its location (**C**) ensuring the tabs (**A**) are pointing downwards as illustrated, ensure it clicks firmly into its airtight position.

- 2) Every 50 working hours inject the gearcase with gear grease under high pressure through hole (**C**).

3) SPARK PLUG

From time to time (at least every 50 hours)

remove and clean the spark plug and check the electrode gap (0,5/0,6 mm.). Replace spark plug about every 100 working hours or whenever it is extremely encrusted. Heavily encrusted electrodes can result from wrong fuel mixture (too much oil in the petrol) or a poor quality of oil in the fuel mix. Check and correct.

4) FUEL FILTER

To change fuel filter remove the tank cap and pull out the filter with a piece of bent wire or long forceps.

5) MOTOR MAINTENANCE

Contact your Service Dealer every 100 working hours.

This will reduce the possibility of unexpected problems and will ensure maximum product life and efficiency.

REGULARLY: it is important, in order to avoid engine overheating, to remove dust and dirt from slots, gaps and from in between cylinder fins using a wooden scraper.

LONG STORAGE: empty fuel tank and run engine until dry.

Store trimmer in a dry place.

M. Replacing nylon line

- 1) Loosen the locking nut on the base of the nylon head by turning it clockwise.
- 2) Remove the base cover assembly.
Remove the empty spool from the housing and discard any remaining line.

REWINDING NEW LINE

- 3) Prepare 2 lengths (8ft each) of 2.4 mm nylon line. Thread 1 end of each line into the two holes on opposite sides of the spool. Pinch the exposed ends flat with a pair of pliers to prevent them slipping through the hole.
- 4) Wind the two lines in the same direction around the spool.

REASSEMBLY

- 5) Slide the end of the two lines into the grooves to hold the line temporarily.
- 6) Position the spool back into the housing and pull the line through the eyelets.
- 7) Pull about 12cm (5ins) of line out on either side.
- 8) Reassemble the nylon string head as illustrated; mower gauge, spring and locking nut (tighten in an anti-clockwise direction).
- 9) **N.B:** In order to extend the nylon line as it wears down, pull the mower gauge downwards and turn it in a clockwise direction to feed out the desired length of line.

N. Ecology

This chapter is about how to maintain the "eco features" of the machine as originally developed by our engineers, the correct use of this machine and handling of waste oil and fuel.

1. Research on the 4 stroke engine has been developed in order to produce lower fuel consumption and low emission of polluting exhaust gases
2. Use of the machinery: During the fuel filling operation particular care should be taken to avoid waste fuel polluting the environment.
3. When storing for a long period, empty fuel tank and run engine until dry, observing the same precautions as when filling.
4. Disposal of machines: Old machines can be very dangerous for the environment - do not throw them away!! Please apply to the competent body authorised to collect industrial waste. As prescribed by National laws on environment

Technical data

DISPLACEMENT (cm ³)	52
ENGINE OUTPUT (Kw) (ISO 8893)	2
BORE AND STROKE (mm)	47x30
ENGINE SPEED AT MAX POWER (min ⁻¹)	7.500
MAXIMUM SPEED, NO LOAD (min ⁻¹)	10.000
MINIMUM SPEED (min ⁻¹)	2.800
BLADE SHAFT SPEED (min ⁻¹)	8.500
BLADE LOCKING NUT TIGHTENING TORQUE (Nm)	17
DRY WEIGHT (kg)	9,5
FUEL TANK CAPACITY (cm ³)	950
Coil/flywheel magneto distance (mm)	0,3
VALVES GAUGE (mm)	0,10/0,15
SOUND PRESSURE LEVEL (AT THE OPERATOR'S EAR) dB(A) (EN 27917)	97
Measured sound power LEVEL LwAav (dBA) (ISO 10884)	108
GUARANTEED NOISE level LwAav (dBA) (ISO 10884)	112
VIBRATIONS LEVEL STRING HEAD (ISO 7916) (m/s ²) MAX-MIN	2.40 - 5.75
VIBRATIONS LEVEL BLADE (ISO 7916) (m/s ²) MAX-MIN	2.40 - 4.57

Fault finding table

	Engine will not start	Engine runs badly or loses power when cutting	The machine runs but does not cut well
Check STOP switch is in the position I.	●		
Control fuel level min. 25% tank capacity.	●	●	
Check air filter is clean.	●	●	
Remove spark plug, dry it, clean it and adjust it, and replace it, if necessary.	●	●	
Change fuel filter. Contact your dealer.		●	
Carefully follow the cutting accessory assembly instructions.			●
Check metal cutting accessory is sharp. Otherwise, contact your dealer.			●

Engine still gives trouble: contact your dealer.