

# Electrolux

*Libretto d'istruzione e uso*

*Notice d'instructions et mode d'emploi*

*Instruction manual*

*Bedienungsanleitung*

*Manual de uso y manutencion*

*Gebbruksaanwijzing*

*Livro de instruções e modo de emprego*

*Instrukcja obsługi i konserwacji*

*Használati utasítás*

*Návod k používání*

*Brugsvejledning*

*Bruksanvisning*

*Bruks- og vedlikeholdsveiledning*

*Käyttöohjeet*

*Navodila za uporabo in vzdrževanje*

*Εγχειρίδιο οδηγιών χρήσης*

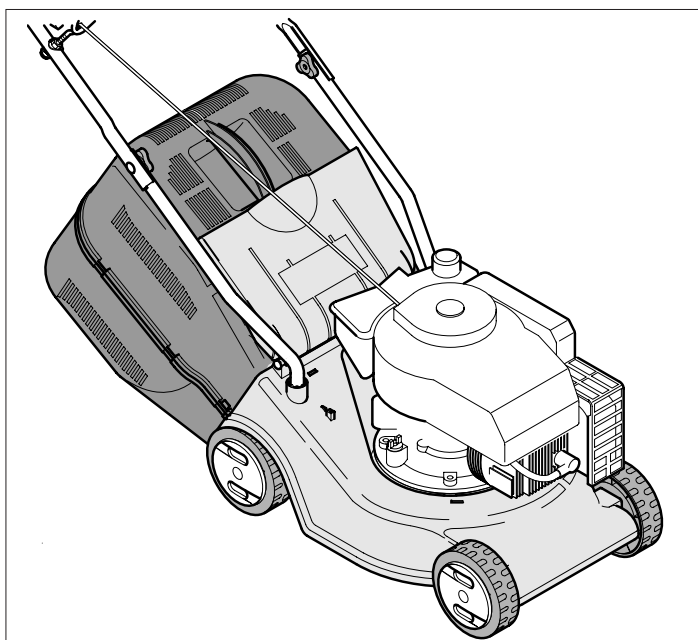

**Rasaerba con motore a scoppio - Lama 40 cm**

**Tondeuse avec moteur à explosion - Lame 40 cm.**

**Lawn mower with petrol engine - 40 cm blade**

**Rasenmäher mit Explosionsmotor - Messer 40 cm**

**Cortadora de hierba con motor de explosión - Cuchilla 40 cm.**

**Grasmaaimachine met verbrandingsmotor - Mes 40 cm.**

**Cortagrama com motor a explosão - Lamina 40 cm.**

**Kosiarka do trawy z silnikiem gazowym - Noż 40 cm.**

**Robbanò-motor hajtású fűnyíró - Kés 40 cm**

**Sekačka na trávu se spalovacím motorem - žací nůž 40 cm**

**Plæneklipper med eksplosionsmotor - 40 cm klinger**

**Grasklipper med eksplosjonsmotor - 40 cm klinger**

**Gressklipper og bensinmotor - 40 cm kniv**

**Räjähdysmoottorilla varustettu ruohonleikkuri - Terä 40 cm**

**Motorna kosilnica - rezilo 40 cm.**

**Χλοοκοπτική μηχανή με κινητήρα εσωτερικής καύσης -**

**Μαχαιρί 40 cm.**

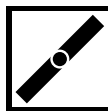

Rasaerba a spinta  
Tondeuse poussée  
Manual lawn mower  
Rasenmäher-Schiebegerät  
Cortadora de hierba de empuje  
Handmaaimachine  
Cortagrama de empurro  
Kosiarka do trawy popychana  
Tolofűnyíró  
Sekačka na trávu bez pojezdu  
Plæneklipper med skubbemotor  
Handdriven grasklippare  
Gressklipper uten drift  
Työnnettävä ruohonleikkuri  
Rocna kosilnica  
*Χλοοκοπτική μηχανή με ώθηση*

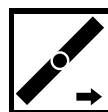

Rasaerba semovente  
Tondeuse automotrice  
Self-propelled lawn mower  
Selbstfahrender Rasenmäher  
Cortadora de hierba propulsada  
Zelfrijdende grasmaaimachine  
Cortagrama semovente  
Kosiarka do trawy samobieżna  
Őnjáró - fűnyíró  
Sekačka na trávu s pojezdem  
Selvkørende plæneklipper  
Sjålvgående grasklippare  
Gressklipper med drift  
Itseliikkuva ruohonleikkuri  
Kosilnica na avtomatski pogon  
*Αυτοκίνητη χλοοκοπτική μηχανή*

*Il presente manuale rappresenta una parte integrante del prodotto. Vi preghiamo di conservarlo per ogni ulteriore utilizzo.*

*Le manuel présent fait partie intégrante du produit; nous vous prions en conséquence de le conserver pour toutes nécessités ultérieures.*

*The present manual constitutes an integral part of the product and it should be kept for all future reference.*

*Das vorliegende Handbuch gehört zu einem festen Bestandteile des Produktes und muss deshalb zur Einsichtnahme sorgfältig aufgehoben werden.*

*El presente manual representa una parte integrante del producto. Les rogamos que lo conserven para cualquier ulterior empleo.*

*Deze handleiding is een integrerend deel van het product. Wij verzoeken u hem te bewaren voor iedere mogelijke nadere raadpleging*

*Este manual representa una parte integrante do produto. Recomendamos guardá-lo para outros usos. Niniejsza instrukcja stanowi integralną część produktu. Prosimy przechowywać ją do każdego dalszego użytkowania.*

*A jelen szakkönyv a termék szerves részét képezi. Kérjük megőrizni minden utólagos használatért. Tato uživatelská příručka je neopomenuteľnou súčasťou výrobu. Uchovajte ju pro ďalší použití.*

*Håndbogen er en integreret del af produktet. Den skal opbevares omhyggeligt for yderligere konsultation. Denna manual utgör en integrerande del av produkten. Vi ber er spara den för senare bruk.*

*Dette håndboken representerer en fullende del av produkten. Det skal oppbevares for alle ytre anvendelser.*

*Tämä käyttöopas kuuluu olennaisena osana tuotteeseen. Säilytä se huolellisesti myöhempää käyttöä varten. Navodila za uporabo in vzdrževanje so sestavni del izdelka, zato prosimo, da jih shranite in upoštevate za nadaljnjo uporabo.*

*To παρόν εγχειρίδιο αποτελεί ένα ολοκληρωτικό μέρος του προϊόντος. Σας παρακαλούμε να το φυλάξετε με προσοχή για κάθε περαιτέρω χρήση.*

I

F

GB

D

E

NL

P

PL

H

SK

CZ

DK

S

N

SF

SLO

GR

La ringraziamo per la fiducia accordataci con l'acquisto del nostro rasaerba. Siamo certi che avrà modo di apprezzare nel tempo e con soddisfazione la qualità del nostro prodotto. La preghiamo di leggere attentamente questo manuale predisposto appositamente per informarla circa il suo uso corretto in conformità ai requisiti essenziali di sicurezza.

Nous vous remercions de la préférence que vous nous avez accordée en choisissant notre tondeuse. Nous sommes persuadés que vous pourrez apprécier dans le temps la qualité de notre produit et que vous en serez entièrement satisfaits. Nous vous prions de lire attentivement ce manuel, spécialement conçu pour illustrer l'utilisation correcte de cette machine, dans le respect des normes de sécurité fondamentales.

We wish to thank you for choosing our lawn mowers. We are confident that the high quality of our machine will meet with your satisfaction and appreciation and that your lawn mower will give you long-lasting service. Before starting to use your machine, make sure to read with care this manual, which has been purposely drawn up to provide you with all the necessary information for proper use, in compliance with basic safety requirements.

Wir danken Ihnen für Ihr Vertrauen, das Sie uns durch den Kauf unseres Rasenmäher entgegengebracht haben und sind sicher, daß Sie mit der Qualität unseres Produkte zufrieden sein werden. Wir bitten Sie, dieses Handbuch aufmerksam durchzulesen, das Sie über die richtige Verwendung in Übereinstimmung mit den Sicherheitsvorschriften informiert.

Le damos las gracias por la confianza que nos ha demostrado al comprar nuestro cortacésped. Estamos seguros de que podrá apreciar con el tiempo y con satisfacción la calidad de nuestro producto. Le rogamos lea atentamente este manual preparado expresamente para informarle sobre el uso correcto con arreglo a los requisitos básicos de seguridad.

Wij danken u voor het vertrouwen waarmee voor u onze maaimachine heeft gekozen. U zult langdurig plezier hebben van de kwaliteit van dit product. Leest u aandachtig dit handboek, dat speciaal bedoeld is om u te informeren over het juiste gebruik ervan volgens de vereiste veiligheidsvoorwaarden.

Agradecemos a preferência que nos deram, escolhendo a nossa cortadora de relva. Estamos seguros que, com o tempo, poderéis apreciar a qualidade dos nossos produtos e ficareis plenamente satisfeitos. Pedimos a leitura atenta deste manual, preparado especialmente para informar da utilização correcta da máquina e das normas de segurança fundamentais.

Gratulujemy Państwa zakupu naszej kosiarki do trawy jesteśmy pewni, że będziecie Państwo usatysfakcjonowani wysoką jakością naszego produktu.

Prosíme o uvažné prečítanie całej instrukcji obsługi i szczegółowe zapoznanie się ze wskazaniami dotyczącymi bezpieczeństwa użytkowania urządzenia.

Köszönjük Fünyírógépgé megvásárlása úján belékhelyezett bizalmat. Biztosak vagyunk, hogy meg lesz elégedve gyártmányunk minőségével. Kérjük, olvassa el figyelmesen ezt az utasítást a helyes használati mód és a biztonsági előírások betartása érdekében.

Děkujeme za Vaši důvěru, kterou jste projevilí nákupem naší sekačky na trávu. Jsme přesvědčeni, že vysoká kvalita našich výrobků splní Vaše očekávání a sekačka Vám bude spolehlivě sloužit po dlouhou dobu. Než sekačku nastartujete, přečtěte si pozorně tento návod k používání, který Vám poskytne všechny nezbytné informace týkající se použití stroje v souladu se základními bezpečnostními předpisy.

Vi takker dig for at have valgt en af vores plæneklippere. Vi er overbeviste om, at maskinens høje kvalitet og præstationer vil tilfredsstille dine forventninger og klippe din plæne lang tid fremover. Læs vejledningen grundigt igennem, da den indeholder vigtige råd til en korrekt anvendelse i overensstemmelse med de vigtigste sikkerhedskrav.

Vi tackar er för det förtroende ni visat oss genom att köpa vår gräsklippare. Vi är övertygade om att ni med tillfredsställelse kommer att uppskatta vår produkts kvalitet under en lång tid framöver. Vi ber er att noggrant läsa denna bruksanvisning som har till uppgift att informera er om hur man ska använda gräsklipparen på ett korrekt sätt i enlighet med nödvändiga säkerhetskrav.

Takk for tilliten du har vist ved å kjøpe vår gressklipper. Vi er sikker på at du i fremtiden vil sette pris på og ha glede av kvaliteten til vårt produkt. Vi ber deg om å lese denne veiledningen for å få all informasjon om riktig bruk i overensstemmelse med de viktigste sikkerhetskravene.

Kiitämme ruohonleikkurimme valinnasta. Olemme varmoja, että tuotteemme tarjoaa parhaan mahdollisen suorituskyvyn ja kestää käytössä pitkään. Lue käyttöopas huolellisesti, sillä se antaa tärkeää laitteen oikeaan ja turvalliseseen käyttöön liittyvää tietoa.

Spoštovani kupci, zahvaljujemo se Vam za nakup enega naših proizvodov in Vam želimo veliko zadovoljstva pri delu z novo kosilnico. Preden pričnete z uporabo kosilnice, pazorno preberite navodila, predstavljena v tem priročniku, da bi spoznali in razumeli njegovo vsebino glede pravilne uporabe kosilnice in temeljnih varnostnih ukrepov pri delu.

Σας ευχαριστούμε για την προτίμησή που μας δείξατε αγοράζοντας την χλοοκοπτική μας μηχανή. Είμαστε βέβαιοι ότι χρησιμοποιώντας την θα μπορέσετε να εκτιμήσετε με ευχαρίστηση την ποιότητα του προϊόντος μας. Σας παρακαλούμε να διαβάσετε προσεκτικά το εγχειρίδιο του συστήματός μας επειδή για να Σας πληροφορήσει κατά σωστό τρόπο όσον αφορά την σωστή χρήση της μηχανής σύμφωνα με τους βασικούς κανόνες ασφαλείας.

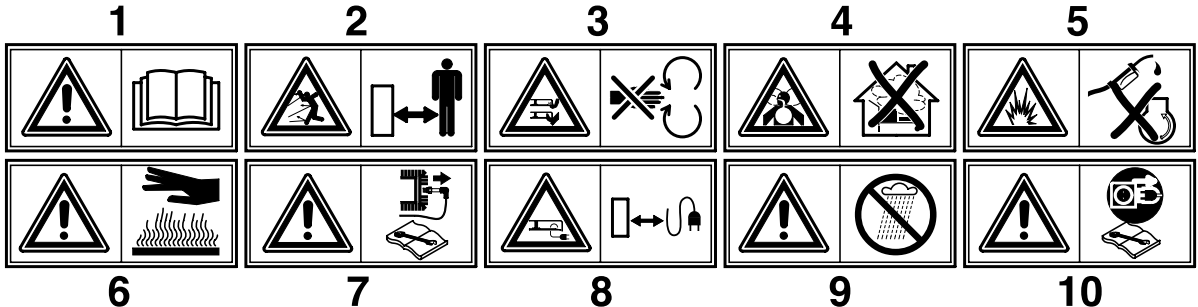

<p><b>1</b> <b>Attenzione!</b> Leggere il manuale di istruzioni prima dell'uso <b>Attention!</b> Lire le manuel d'instructions avant utilisation. <b>Caution!</b> Read the instruction manual before use. <b>Achtung!</b> Vor der Verwendung ist die Bedienungsanleitung zu lesen.</p>	<p><b>Atención!</b> Leer el manual de instrucciones antes del uso. <b>Pas op!</b> De gebruiksaanwijzing voor het gebruik nauwkeurig doorlezen. <b>Atenção!</b> Ler o manual de instruções antes do uso. <b>Uwaga!</b> Przed użyciem przeczytać instrukcję obsługi.</p>	<p><b>Figyelem!</b> Elosvasni az utasításokat a használat előtt. <b>Upozornění!</b> Než začnete sekačku používat, pozorně si prostudujte návod k používání. <b>Forsigtig!</b> Læs vejledningen igennem inden ibrugtagning. <b>Varning!</b> Läs bruksanvisningen innan ni använder gräsklipparen</p>	<p><b>Advarsel!</b> Les bruksveiledningen før bruk. <b>Huomio!</b> Lue käyttöopas huolellisesti ennen laitteen käyttöönottoa. <b>Pozor!</b> Pazorno preberite navodila preden pričnete z uporabo kosilnice. <b>Προσοχή!</b> Διαβάστε προσεκτικά το εγχειρίδιο οδηγιών πριν από την χρήση.</p>
<p><b>2</b> Tenere le persone estranee fuori dalla zona di pericolo! Eloigner toute personne étrangère de la zone dangereuse! Keep other people well away from the danger area! Unbefugte dürfen nicht in den Gefahrenbereich gelangen!</p>	<p>Mantener al personal ajeno fuera de la zona de peligro! Zorg ervoor dat andere personen buiten de gevaarzone blijven! Mantir pessoas estranhas fora da zona de perigo Osoby postronne nie powinny przebywać w zasięgu pracy urządzenia.</p>	<p>A veszélyes területen ne tartózkodjanak idegenek! V nebezpečné vzdálenosti se nesmí zdržovat cizí osoby! Hold uvedkommende personer på sikker afstand af farezonen! Håll alla obehöriga på avstånd från riskområdet!</p>	<p>Hold uvedkommende utenfor faresonen! Älä anna asiattomien henkilöiden oleksella vaara-alueella! Oddaljite tuje osebe iz delovnega območja kosilnice! Απομακρύνετε τα άσχετα πρόσωπα από τον χώρο κινδύνου.</p>
<p><b>3</b> <b>Attenzione!</b> pericolo ferimento mani e piedi. <b>Attention!</b> Danger de blessures des mains et des pieds. <b>Warning:</b> Risk of hand and feet injury. <b>Achtung:</b> Hand- und Fussverletzung</p>	<p><b>Atención:</b> peligro heridas a manos y pies. <b>Let op,</b> gevaar voor verwondingen aanhanden en voeten. <b>Atenção,</b> perigo machucamento mãos e pés. <b>Uwaga,</b> wirujący nóż niebezpieczeństwo zranienia rąk i nóg.</p>	<p><b>Figyelem,</b> veszély: kezek és lábak megsebzése. <b>Pozor,</b> nebezpečí poranění rukou a nohou. <b>Forsigtig!</b> Fare for tilføjelse af sår på hænder og fødder. <b>Varning:</b> risk för skada på händer och fötter.</p>	<p><b>Advarsel:</b> Fare for å skade hendene og føttene. <b>Huomio:</b> käsien ja jalkojen loukkaamisen vaara. <b>Pozor!</b> Nevartnostno poškodob rok in nog! <b>Προσοχή!</b> Κίνδυνος τραυματισμού χεριών και ποδιών.</p>
<p><b>4</b> Pericolo di aspirazione di gas tossici! Non utilizzare l'apparecchio in ambienti chiusi o poco ventilati. Danger of inhalation of gas, toxiques! Ne pas utiliser l'appareil dans des espaces fermés ou peu ventilés. Risk of breathing in toxic gases! Do not use the appliance in closed or poorly ventilated environments. Gefahr des Einatmens giftiger Gase! Das Gerät darf nicht in geschlossenen oder schlecht belüfteten Räumen verwendet werden.</p>	<p>Peligro de aspiración de gases tóxicos! No utilizar el aparato en ambientes cerrados o poco ventilados. Gevaar voor inademing van giftige gassen! Gebruik het apparaat niet in gesloten of niet goed geventileerde ruimtes. Perigo de aspiração de gás tóxicos! Não utilizar o aparelho em lugares fechados ou pouco ventilados. Niebezpieczeństwo wdychania gazów trujących! Nie używać urządzenia w pomieszczeniach zamkniętych lub o słabym przewietrzeniu.</p>	<p>Mérgező gázak belégzése veszély! Ne használja a gépet zárt vagy kevésbé szellőztetett helyiségekben. Nebezpečí vdechování toxických plynů! Výrobek nesmí být používán v uzavřených nebo nedostatečně větrávaných prostorách. Fare for inandning av giftiga gasser! Använd aldrig maskinen i lukkede eller dårligt ventilerade rum. Risk för inandning av giftiga gaser! Använd inte apparaten i stängda eller dåligt ventilerade lokaler.</p>	<p>Fare for å puste inn giftige gasser! Ikke bruk apparatet i lukkede eller dårlig ventilerte lokaler. Myrkyllysten kaasujen hengittämisen vaara! Älä käytä laitetta suljettuissa tai riittämättömästi ilmastoiduissa tiloissa. Nevartnostno vdihavanja strupenih izpušnih plinov! Nikoli ne uporabljajte kosilnice v zaprtim ali slabo zravenem prostoru. Κίνδυνος εισπνοής τοξικών αερίων. Μη χρησιμοποιείτε την συσκευή σε κλειστούς ή λίγο αεριζόμενους χώρους.</p>
<p><b>5</b> <b>Pericolo di esplosione!</b> Non effettuare rabbocchi di carburante con motore in moto. <b>Danger d'explosion!</b> Ne pas faire le plein de carburant, moteur en marche. <b>Risk of explosion!</b> Do not top up with fuel with engine running. <b>Explosionsgefahr!</b> Treibstoff darf nicht bei laufendem Motor nachgefüllt werden.</p>	<p><b>Peligro de explosión!</b> No rellenar con carburante cuando el motor está encendido. <b>Gevaar voor explosie!</b> Vul geen brandstof met draaiende motor bij. <b>Perigo de explosão!</b> Não juntar o carburante com o motor em função. <b>Niebezpieczeństwo wybuchu!</b> Nie przelewać paliwa przy zapalonym silniku</p>	<p><b>Robbanásveszély!</b> Ne hajtani végre az uzemanyag toltást amikor a motor mukodésben van. <b>Nebezpečí výbuchu!</b> Pohonné hmoty je zakázáno doplňovat pokud je motor v chodu. <b>Explosionsfare!</b> Fyld aldrig brændstof på med motoren tændt. <b>Risk for explosion!</b> Udfør inte påfyllning av bränsle med motorn igång.</p>	<p><b>Fare for eksplosjon!</b> Ikke etterfyll drivstoff med motoren i gang. <b>Räjähdyksen vaara!</b> Älä suorita polttoainesäätötyynyttä moottorin käydessä. <b>Nevartnostno eksplozije!</b> Ne nalivajte gorivo v kosilnico, ko motor deluje. <b>Κίνδυνος έκρηξης!</b> Μη βάζετε τα καύσιμα με τον κινητήρα στο κίνηση.</p>
<p><b>6</b> <b>Attenzione!</b> Superficie calda. <b>Attention!</b> Surface chaude <b>Caution!</b> Hot surface <b>Achtung!</b> Oberfläche ist heiß.</p>	<p><b>Atención!</b> Superficie caliente <b>Pas op!</b> Warm oppervlak <b>Atenção!</b> Superfície quente <b>Uwaga!</b> Powierzchnia gorąca</p>	<p><b>Figyelem!</b> Meleg felület. <b>Výstraha!</b> Horký povrch. <b>Forsigtig!</b> Varm overlade. <b>Varning!</b> Mycket het yta.</p>	<p><b>Advarsel!</b> Varm overlade <b>Huomio!</b> Kuum pinta. <b>Pozor!</b> Vroca površina. <b>Προσοχή!</b> Επιφάνεια θερμή.</p>
<p><b>7</b> <b>Attenzione!</b> Spegner il motore e staccare la candela prima di effettuare qualunque manutenzione <b>Attention!</b> Eteindre le moteur et enlever la bougie avant d'effectuer quelque opération d'entretien que ce soit. <b>Caution!</b> Switch off the engine and disconnect the spark plug before undertaking any maintenance work. <b>Achtung!</b> Vor der Ausführung jeglicher Wartungsarbeiten ist der Motor abzuschalten und die Zündkerze abzuklemmen.</p>	<p><b>Atención!</b> Apagar el motor y extraer la bujía antes de efectuar cualquier manutención <b>Pas op!</b> De motor uitzetten en de bougie ontkoppelen alvorens enige onderhoudshandeling uit te voeren. <b>Atenção!</b> Desligar o motor e a vela antes de qualquer manutenção <b>Uwaga!</b> Przed wykonaniem jakiegokolwiek konserwacji zgasić silnik zdjąć przewód ze świecy</p>	<p><b>Figyelem!</b> Kikapcsolni a motort és kiiktatni a gyertyát minden karbantartási művelet előtt. <b>Výstraha!</b> Před zahájením jakékoli údržby stroje vypněte motor a odpojte kabel ze zapalovací svíčky. <b>Forsigtig!</b> Enhver form for vedligeholdelse skal ske med slukket motor og frakoblet tændrør. <b>Varning!</b> Stäng av motorn och lossa tändstiftet innan något som helst ingrepp för underhåll utförs.</p>	<p><b>Advarsel!</b> Slå av motoren og kople fra tennpluggen for det utføres vedlikehold. <b>Huomio!</b> Sammuta moottori ja irrota sytytystulppa ennen minkään huolto- tai korjaustöiden aloittamista. <b>Pozor!</b> Ugasnite motor in smenite kabel s svećke pred kakršnekoli vzdrževalnem delu. <b>Προσοχή!</b> Σβήνετε τον κινητήρα και αποσυνδέστε το πηνίο κόνισης πριν από οποιαδήποτε επέμβαση συντήρησης.</p>
<p><b>8</b> Tenere il cavo di alimentazione lontano dall'utensile tagliente. Ecarter le câble d'alimentation de l'outil tranchant. Keep the power supply cable well away from the cutting tool. Das Speisekabel darf nicht in den Bereich des Schneidwerkzeuges gelangen.</p>	<p>Mantener el cable de alimentación lejos de la herramienta de corte. De voedingskabel op afstand van de maairichting houden. Mantir pessoas estranhas fora da zona de perigo. Przewód zasilający nie może znajdować się w zasięgu pracy noża.</p>	<p>A veszélyes területen ne tartózkodjanak idegenek! Zákaz zdržavania sa cudzích osôb v nebezpečnej oblasti. Strömtilforselskabelt må ikke være i nærheden af skæreredskabet. Håll matningskabeln på säkert avstånd från klippningsverktöget.</p>	<p>Hold strømkabel i god afstand fra kniven. Pidä virtajohto kaukana leikkaavasta terästä. Vedno ohranite razdaljo med elektricnim kablom in rezilom. Κρατάτε το τροφοδοτικό καλώδιο μακριά από το κοφτερό εργαλείο.</p>
<p><b>9</b> <b>Attenzione!</b> Proteggere dalla pioggia e dall'umidità. <b>Attention!</b> Protéger de la pluie et de l'humidité. <b>Caution!</b> Shelter from rain and humidity. <b>Achtung!</b> Vor Regen und Nässe schützen.</p>	<p><b>Atención!</b> Proteger de la lluvia de la humedad. <b>Voorzichtig!</b> Beschermen tegen regen en vocht. <b>Atenção!</b> Proteger contra a chuva e a humidade. <b>UWAGA!</b> Zabezpieczyć przed deszczem i wilgocią.</p>	<p><b>Figyelem!</b> Övni az esőtől és a nedvességtől. <b>POZOR!</b> Chránit před deštěm a vlhkem. <b>BEWAAR!</b> Skak beskyttes mod regn og fugtighed <b>Varning!</b> Skyddas från regn och fukt.</p>	<p><b>Pas på!</b> Beskyttelse mot regn og fuktighet. <b>Voritus!</b> Suojele sateelta ja kosteudelta. <b>Pozor!</b> Zaščitite pred dežjem in vlažnostjo. <b>Προσοχή!</b> Προστατεύετε από την βροχή και την υγρασία</p>
<p><b>10</b> Prima di qualsiasi intervento sull'utensile tagliente togliere la spina di alimentazione Déconnecter la fiche avant d'intervenir sur l'outil tranchant Before carrying out any operations on the cutting tool, disconnect the plug Vor jeglicher Arbeit am Schneidwerkzeug den Stecker abnehmen</p>	<p>Antes de intervenir en la herramienta de corte quitar la clavija Voor alle onderhoudswerkzaamheden aan de snijrichting de stekker uittrekken Afastar o cabo de alimentação da parte de corte. Przewód zasilający nie powinni znajdować się w zasięgu pracy noża.</p>	<p>Elektromos kábelát a pengétől távolítani Elektrická snúra musí byť d'aleka od rezacieho nástroja. Tag stikket ud af stikkontakten, inden der røres ved kniven. Innan något som helst ingrepp på klippningsverktöget sker, tag ut kontakten för elektrisk matning.</p>	<p>Ta av tillfångstspelen for alle inngrepene på verktøyet. Irrota pistotulppa pistorasiasta ennen minkään leikkaavaan terään tehtävää toimenpiteen suorittamista. Ugasnite motor in smenite elektrčni kabel pred kakršnekoli vzdrževalnem delu. Προτού κάνετε οποιαδήποτε επέμβαση στο κοφτερό εργαλείο βγάλτε το φως τροφοδοσίας.</p>

**A DESCRIPTION** (starts at page 35)

1	Upper handles	7	Deck	13	Throttle lever
2	Lower handles	8	Adjusting cutting height	14	Engine stop lever
3	Fastening knobs for upper handles	9	Spark plug	15	Reduction gear
4	Grass catcher	10	Fuel cap	16	Clutch lever
5	Oil filler cap	11	Engine start-grip		
6	Oil drain plug	12	Rear deflector		

**B C ASSEMBLY OF GRASS CATCHER** (starts at page 35)

'If applicable'

**D ASSEMBLY REAR DEFLECTOR** (starts at page 35)**E ASSEMBLY** (starts at page 36)**Manual lawn mower**

Assemble the handle and fit the brake lever with the pin and clip provided, assemble wheels as shown and throttle if supplied.

**F ASSEMBLY** (starts at page 37)**Self-Propelled**

Assemble the handle and fit the levers with pins and clips provided, assemble wheels as shown and throttle if required.

**G ADJUSTMENT OF CUTTING HEIGHT** (starts at page 38)

When fitting and adjusting the wheels tilt the machine slightly.  
Do not tilt the machine more than 30° when fitting or adjusting the wheels

**H SAFETY PRECAUTIONS** (starts at page 38)

- Always operate with the deflector or grasscatcher in the correct position.
- Always stop the engine before removing the grasscatcher or adjusting the height of cut.
- Never place your hands or feet underneath the deck or into the rear grass discharge chute while the engine is running.

(starts at page 38)

Before mowing, remove all foreign objects from the lawn which may be thrown by the machine. While mowing, stay alert for any foreign objects which may have been missed.  
Never lift the rear of the mower while starting the engine or during normal operation.

(starts at page 38)

Never place your hands or feet underneath the deck or into the rear discharge chute while the engine is running.

**K OPERATION** (starts at page 38)**ENGINE ADJUSTMENTS**

Refer to the engine manufacturer's maintenance manual.  
CAUTION:- 0.6l Oil must be added to the engine before use.

(starts at page 39)

**STARTING THE ENGINE**

Once the machine has been set up properly, start the engine as follows:

**a) Engines with choke system:**

when the engine is cold, position the accelerator lever (13) on START

b) Operate the engine stop lever (14) to prepare the engine for start, keep lever pressed against handle while starting and using the machine - it operates the engine brake.

**c) Engines with primer system:**

Press the fuel-enrichment pump (Picture 'K' item 27) located on the carburettor 3 or 4 times position the accelerator lever (13) on MAX.

For further information and explanations, read carefully the user instruction manual of the engine.

**d) Start engine.**

**MANUAL STARTING:** (While holding the engine stop lever (14)).

• Hold the engine start-grip (11) and pull the starter rope gently until you feel the resistance caused by compression. Return the starter rope slowly then pull the handle firmly towards you to its full extent.

**M** (starts at page 39)

Keep the engine stop lever (14) depressed during machine operation. When the lever is released, the engine stops.

**MOWING**

To cut the grass, push the lawn mower manually

**N** (starts at page 39)

Keep the engine stop lever (14) depressed during machine operation. When the lever is released, the engine stops.

**MOWING**

To cut the grass, push the lawn mower manually or insert the automatic advance gear.

**How to insert automatic advance:** Lift up the clutch handle (16) and keep it pressed in position.

**CAUTION:** Engage the gear only when the engine is running.

**How to disengage advance:** Release the clutch handle.

**O** (starts at page 39)

**Important:** If, when you press the clutch lever, the automatic advance gear does not engage, the clutch cable should be adjusted by inserting the spring (P) in one of the subsequent holes (R).

## P

**AUTOMATIC ADVANCEMENT** (starts at page 39)

Periodically check the automatic advance assembly and make sure to keep it clean. In particular, the pinion (17) and the gear (18) must be kept perfectly clean. To carry out this check, you must remove the wheel (19) by unscrewing the screw (20).

**IMPORTANT - Once the product has fuel or oil in the tanks do not tilt the machine at an angle of more than 30°.**

**SAFETY RULES****Training**

- a) Persons under 16 years of age and persons who are not familiar with the user instructions must not use the lawn mower.
- b) The operator is responsible for the safety of other people in the working area. Keep children and domestic animals at a safe distance when the lawn mower is in use.
- c) This machine is to be used exclusively for cutting natural grass. Never use the mower for other purposes (e.g., for flattening out bumps in the ground, such as mole-hills or ant-hills).
- d) Work only when there is sufficient light.
- e) Before mowing, remove all foreign objects from the lawn which may be thrown by the machine. While mowing, stay alert for any foreign objects which may have been missed.

**Setting up and operating the lawn mower**

- a) When mowing, wear strong footwear (boots or heavy shoes) and long trousers.
- b) Before you start mowing, make sure that the blade and blade fixing screw are securely fastened. If the blade is damaged, it must be replaced.
- c) Turn off the engine, wait until the blade has stopped and remove the spark plug cap before:
  - transporting, lifting or moving the machine away from the working area;
  - carrying out maintenance or cleaning, or when carrying out any operation on the blade;
  - adjusting the cutting height;
  - leaving the machine unattended.

**Caution! The blade starts turning as soon as the engine is started**

- d) **Caution!** The fuel is highly inflammable:
  - Store fuel in containers specifically designed for this purpose.

- Refuel outdoors only and do not smoke while refuelling.
- Fill up the fuel tank before starting the engine. Under no circumstances open the fuel tank cap or add petrol when the engine is running or when it is still hot.
- If the petrol has overflowed, do not under any circumstances start up the engine. Move the mower away from the area where fuel has been spilt and avoid any source of possible ignition until the petrol fumes have dissipated.
- Replace the fuel tank cap and tighten it down firmly.
- e) Do not operate the engine in a confined space where dangerous carbon monoxide fumes can collect.
- f) When mowing, never run; you must always walk.
- g) Exercise extreme caution when turning or when pulling the lawn mower towards you.
- h) Particular precautions must be taken when mowing on slopes or downhill stretches:
  - Use appropriate antislip footwear.
  - Always be sure of your footing.
  - Mow across the face of slopes, never up or down.
  - Take great care when changing direction.
  - Do not mow on excessively steep slopes.
- i) Never use the lawn mower unless the guards and safety devices (e.g. deflector, grass catcher) are securely in position and in good condition.
- j) Ensure that the grass catcher and deflector are correctly located. Failure to do so may result in foreign objects being ejected by the blade.
- k) For reasons of safety, the engine must never exceed the speed. (r.p.m.) indicated on the label.
- l) Take care when starting the engine and be sure to follow the user instructions. Never place your hands or feet underneath the deck or into the rear discharge chute while the engine is running.

m) Never lift the rear of the mower while starting the engine or during normal operation.

n) If the blade happens to hit any obstacle, stop the engine at once and remove the spark plug cap. Then get an expert to examine the blade.

**Maintenance and storage**

- a) Make sure that all nuts, bolts, and screws are kept well tightened to keep the mower in a safe operating condition.
- b) Never leave the machine with fuel in the tank within an enclosed area where the fuel vapours could reach naked flames or sparks.
- c) Allow the engine to cool before storing in any enclosure.
- d) Keep the engine, silencer, battery compartment and petrol tank free from grass, leaves and excess lubricant, in order to reduce the danger of fire.
- e) Frequently check the grass catcher for wear or deterioration
- f) For safety reasons, be sure to replace worn-out or damaged parts in due time.
- g) If the fuel tank has to be drained, it is essential that this be done outdoor.
- h) Assemble the blades following the corresponding instructions and use only blades bearing the maker's name or the trademark of the manufacturer or supplier and marked with the reference number.
- i) To protect hands during disassembly or assembly of the blades, it is absolutely essential to wear suitable protective gloves.

**MAINTENANCE**

**Caution!** Switch off the motor and disconnect the spark plug before undertaking any maintenance work.

- For a four stroke engine, check the oil level and change the oil when dirty. For further explanation, see ENGINE INSTRUCTION BOOK.
- Frequently check the mower and ensure that all grass deposits are removed from beneath the deck.
- Never clean the mower by pouring water over it: this may seriously damage the electric start system.
- Take care, the exhaust muffler may be very hot.
- Frequently remove the wheel screws clean white petroleum and oil before replacing. Ball bearings must be greased before remounting.
- Frequently check the blade for damage.
- The lawn mower must be checked by a SERVICE DEALER.

## Q

**BLADE** (starts at page 39)

- To remove the blade (21) unscrew the screw (22).
- Check the conditions of the blade-support (23), the washer (24), the key (25) and the washer (26) and replace any parts which are damaged.
- When reassembling, make sure that the key (25) is correctly seated in the shaft and that the cutting edges face in the direction of the engine rotation. The blade screw (22) must be torqued to 5,34 Kgm (52,4 Nm).



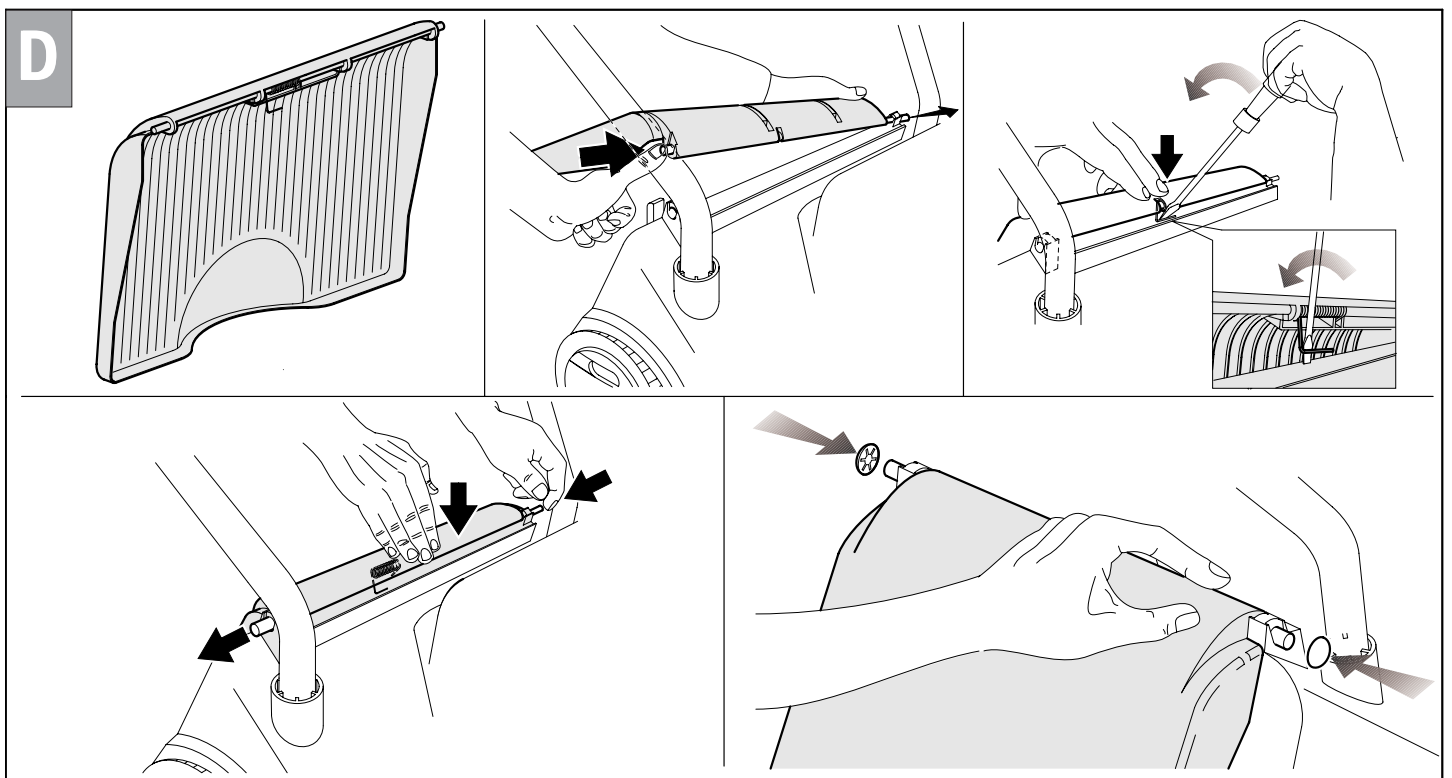
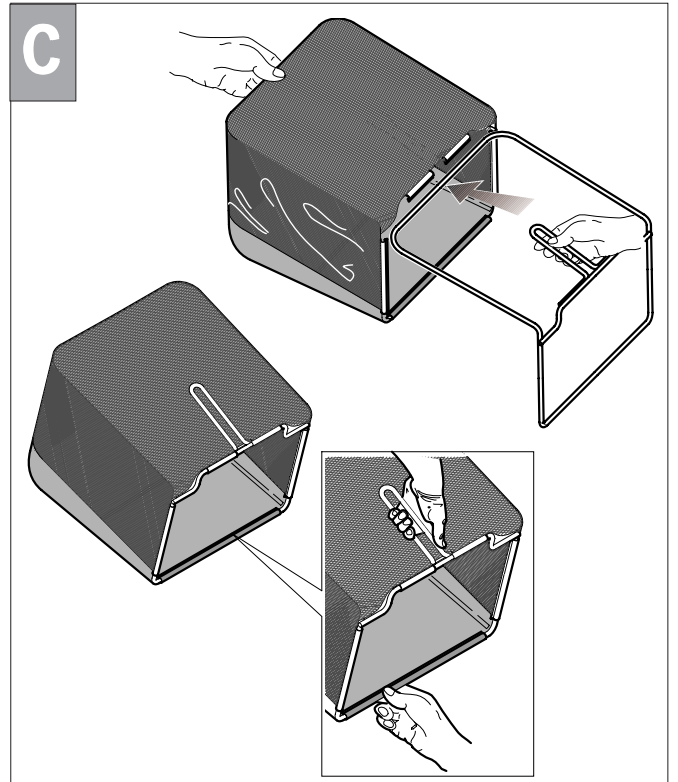
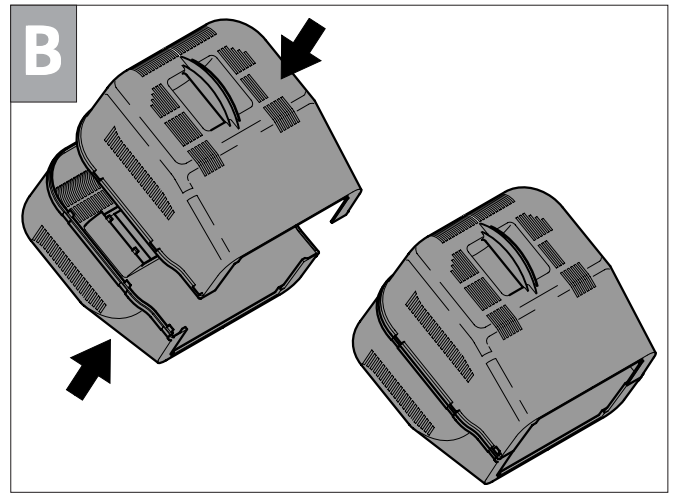
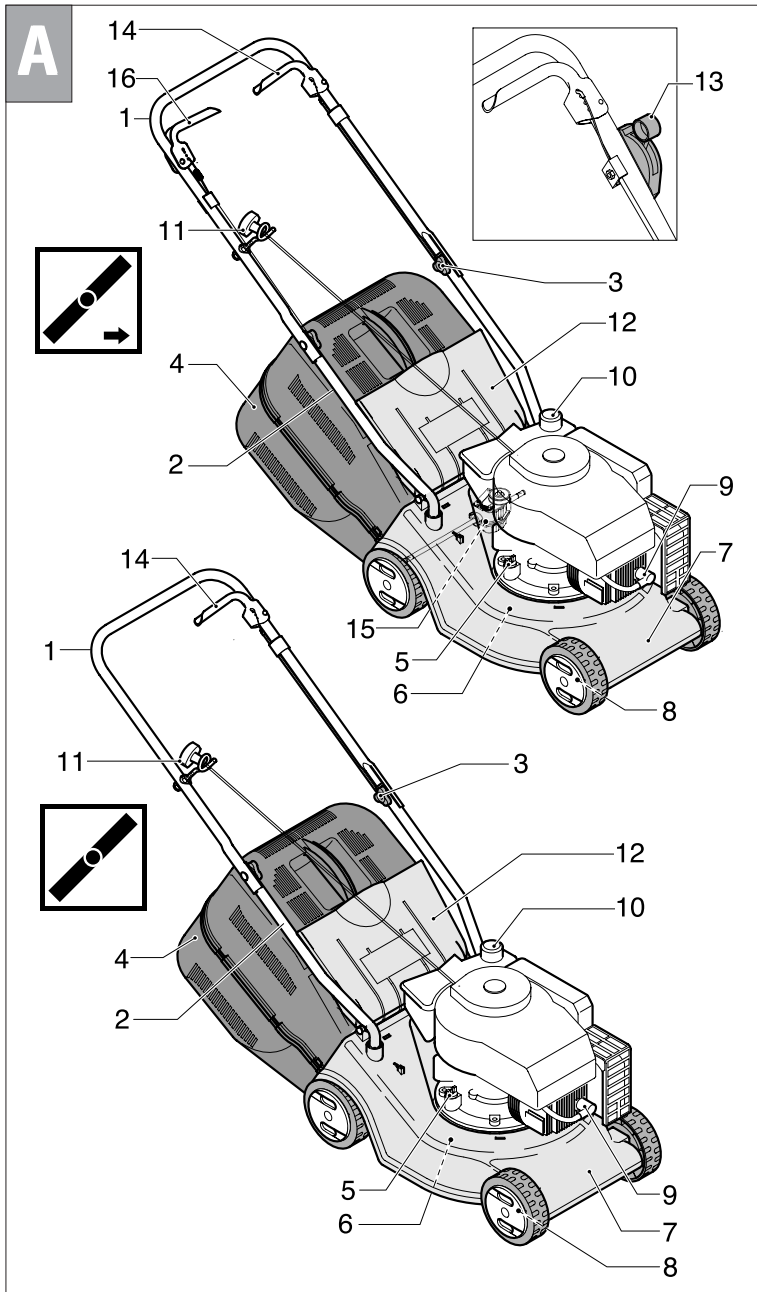

E

